

R30-4 gun  
S&A during electrode assembly  
installation and laser retro-reflection  
evaluation  
with various pucks  
Including CMM on Puck #35

C. Hernandez-Garcia, G. Palacios-Serrano, M. Stutzman, S. Zhang,  
B. Mares, C. Gould, S. Hardisty, R. Ammons, E. Mosby

May 8, 2024

R30-4 gun electrode assembled on April 25, 2024  
with 16/30 front end



R30-4 gun puck retainer assembly orientation

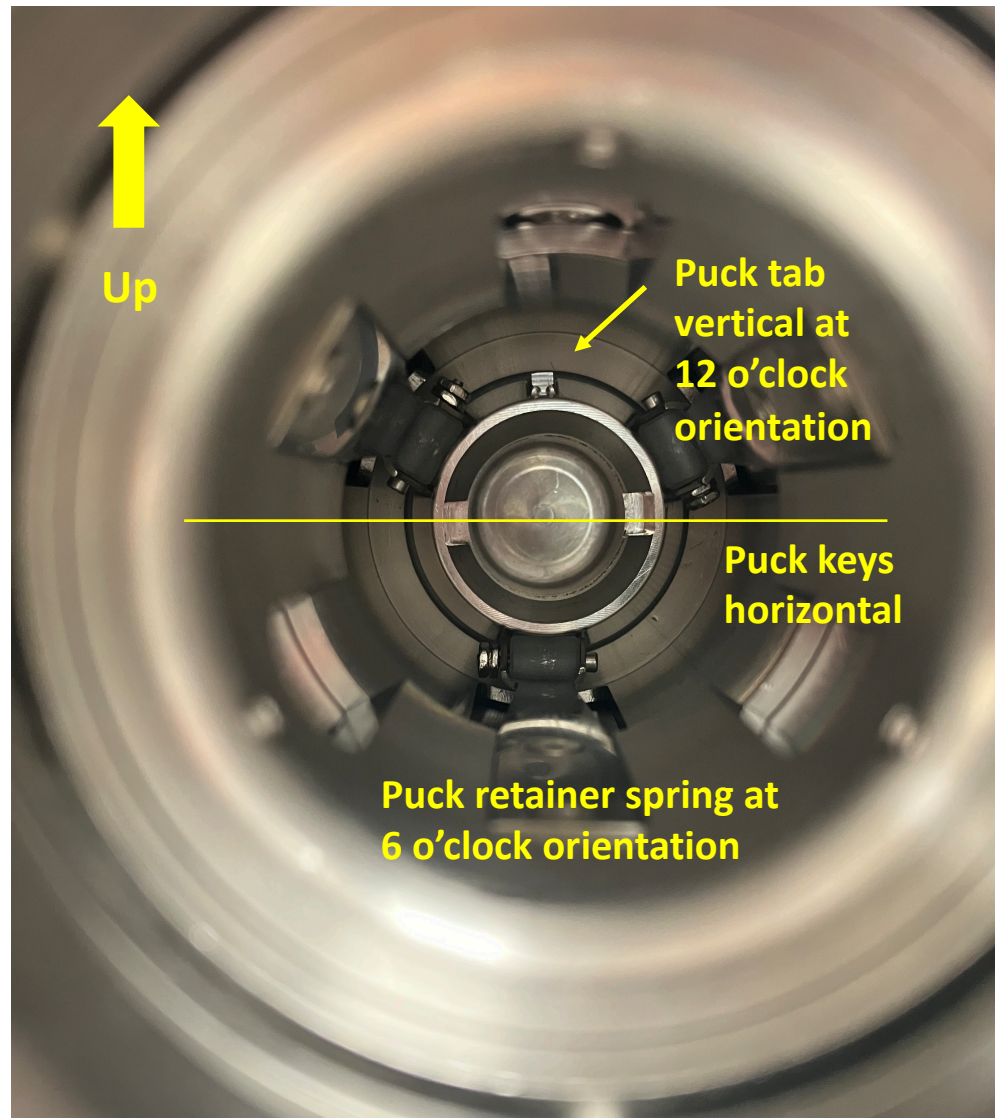

R30-4 back end zoomed in showing orientation of puck  
retainer assembly to be used for installing puck with  
ear (tab) up

# S&A setup to evaluate laser retro-reflection with R30-4 electrode installed to gun high voltage chamber

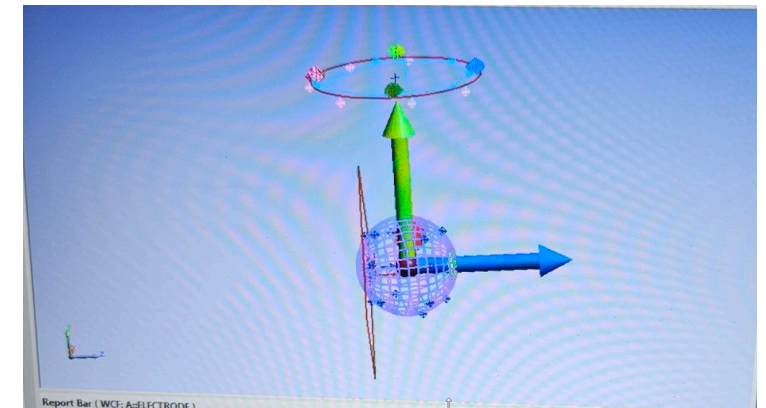
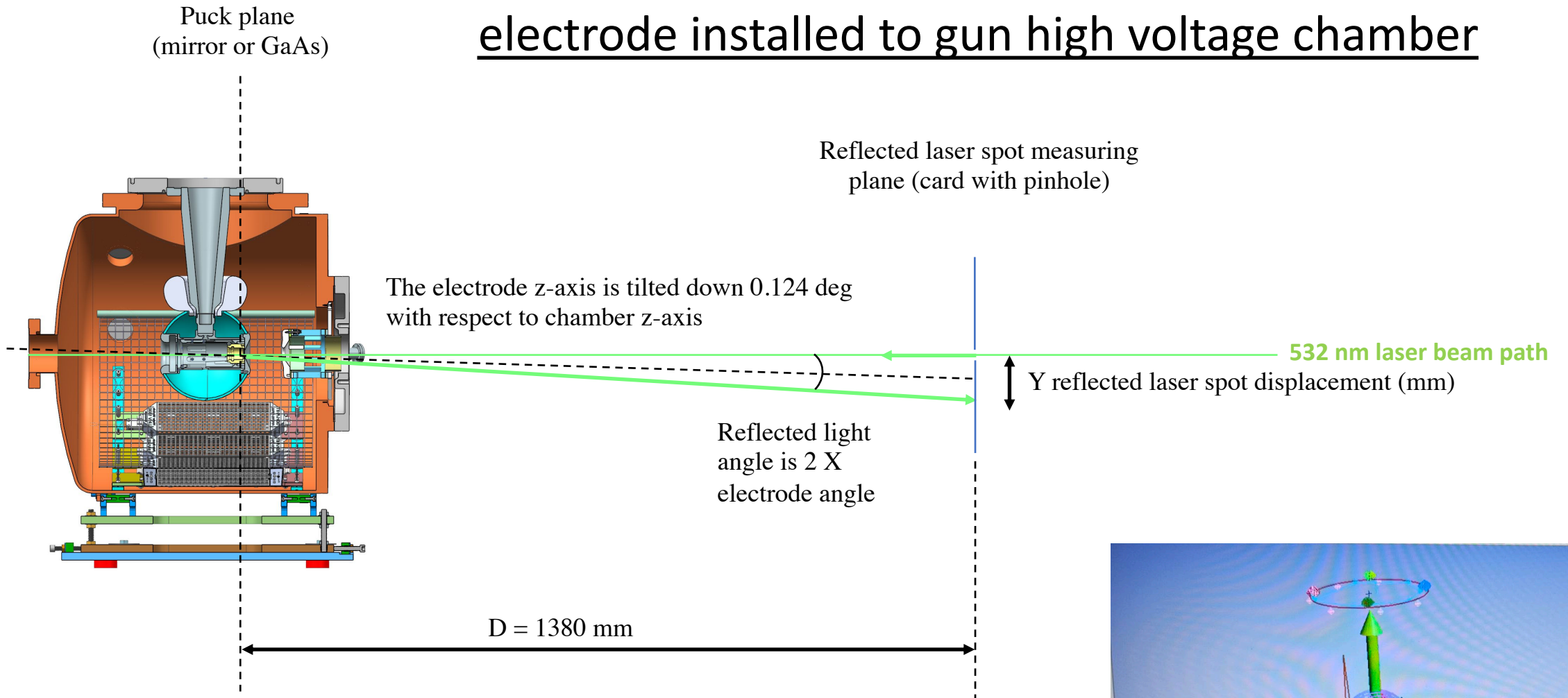

S&A reports that the electrode z-axis is 0.124 deg pointing down wrt to the gun HVC z-axis

# First with the laser launch colinear with R30-4 gun high voltage chamber

Mirror puck  
ear up

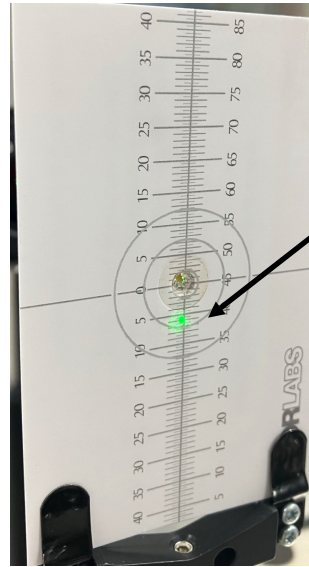

z-axis

Mirror puck

$$\theta = \text{atan}(Y/D)$$

Y = 6 mm

D = 1380 mm

Reflection  $\theta = 0.249^\circ$

Electrode z-axis angle =  $\theta/2 = 0.124^\circ$

**Agrees with S&A measurement**

High voltage chamber

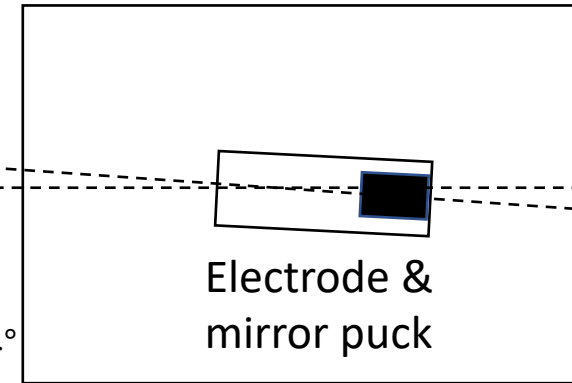

Electrode &  
mirror puck

$\theta = 0.124^\circ$

GaAs wafer on Moly  
puck # 35 ear up

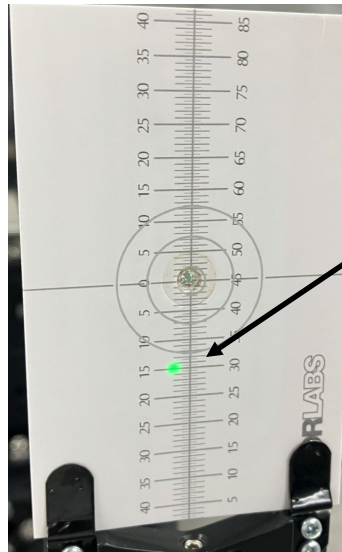

GaAs on Moly puck # 35.

$$\theta = \text{atan}(Y/D)$$

Y = 15 mm

D = 1380 mm

Reflection  $\theta = 0.624^\circ$

GaAs puck # 35 z-axis angle =  $\theta/2 = 0.312^\circ$

High voltage chamber

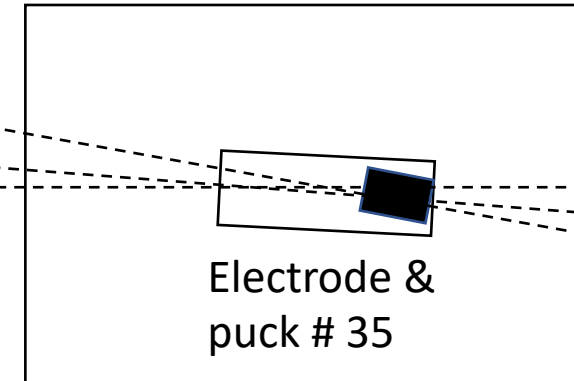

Electrode &  
puck # 35

$\theta = 0.312^\circ$

**Is the Moly puck z-axis tilted?**

**Or is the GaAs wafer plane tilted wrt to the moly puck z-axis?**

Next, and for the rest of measurements, the laser launch was made  
colinear with R30-4 gun electrode z-axis

### Mirror Puck

$Y = 1.5 \text{ mm}$   
 $D = 1380 \text{ mm}$   
Reflection  $\theta = 0.062^\circ$

**Mirror puck z-axis  
angle =  $\theta/2 = 0.031^\circ$**

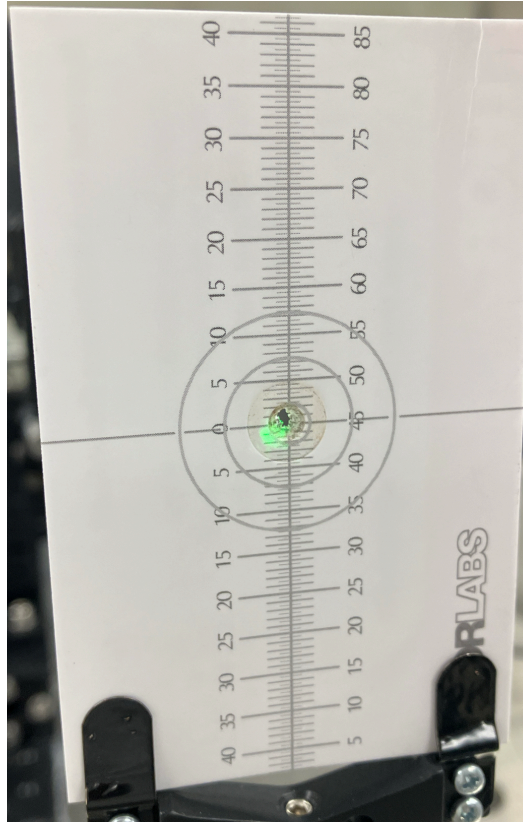

Ear to the left

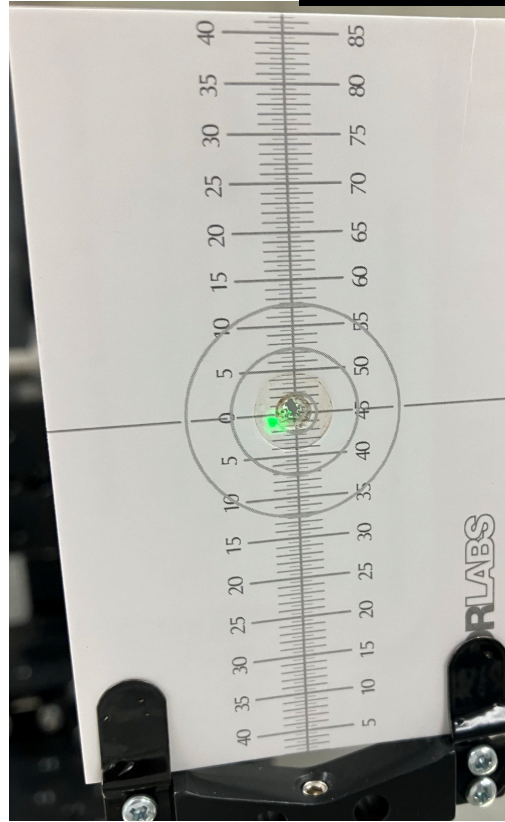

Ear up

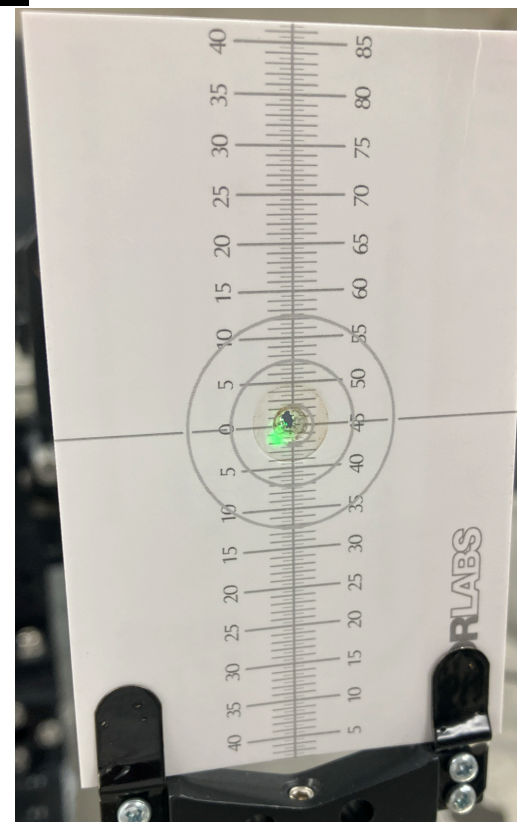

Ear to the right

# Laser colinear with R30-4 gun electrode z-axis

## Bulk GaAs on Puck # 35

Y = 10 mm

D = 1380 mm

Reflection  $\theta = 0.416^\circ$

**Bulk GaAs on puck # 35 z-axis angle =  $\theta/2 = 0.208^\circ$**

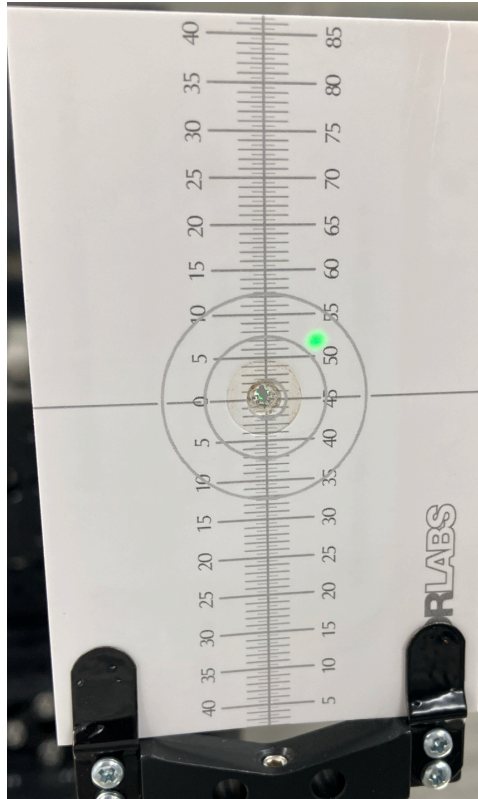

Ear to the left

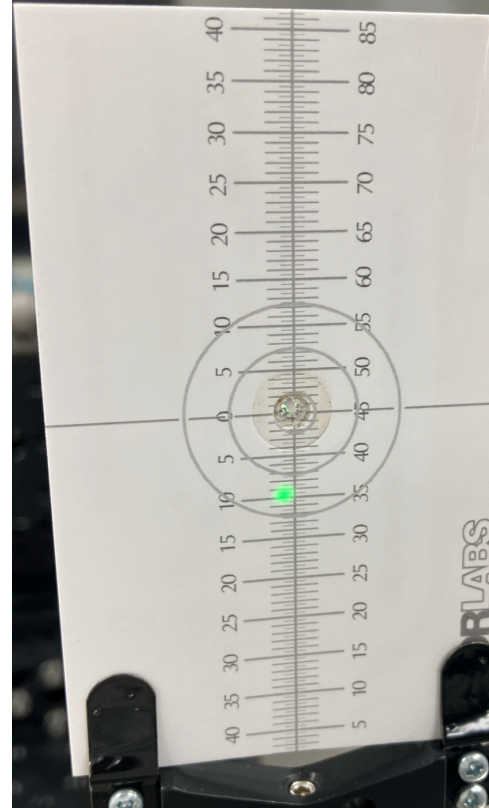

Ear up

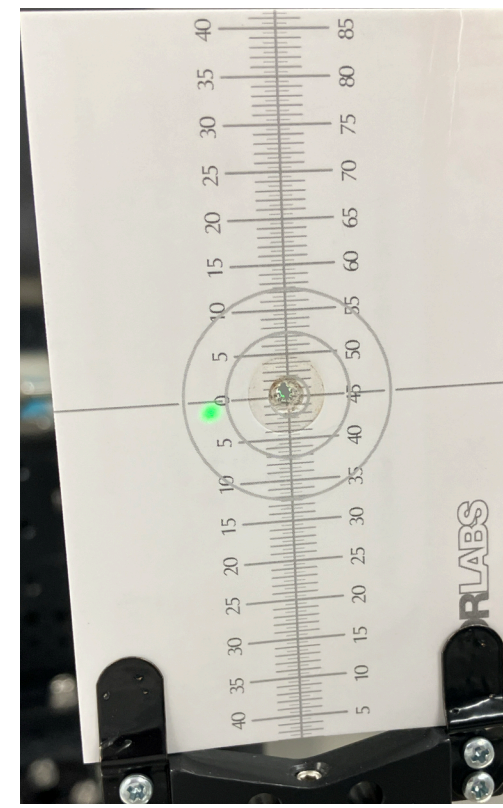

Ear to the right

Laser colinear with R30-4 gun electrode z-axis  
SSL GaAs on Puck # 31

Y = 7 mm  
D = 1380 mm  
Reflection  $\theta = 0.290^\circ$

**SSL GaAs on puck # 31 z-axis angle =  $\theta/2 = 0.145^\circ$**

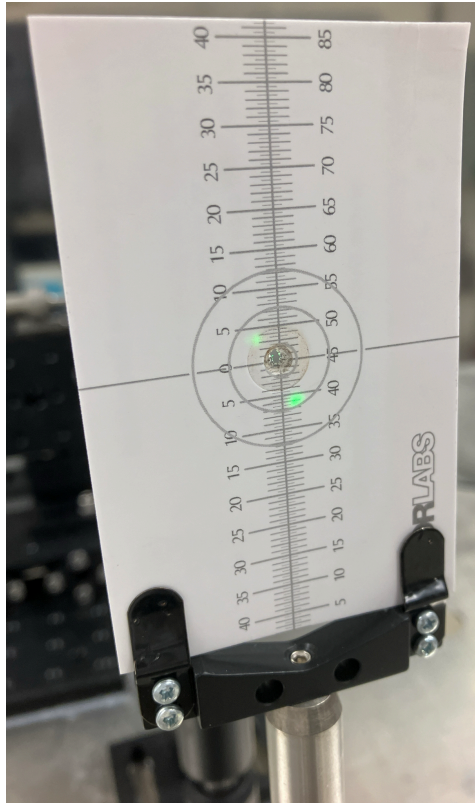

Ear to the left

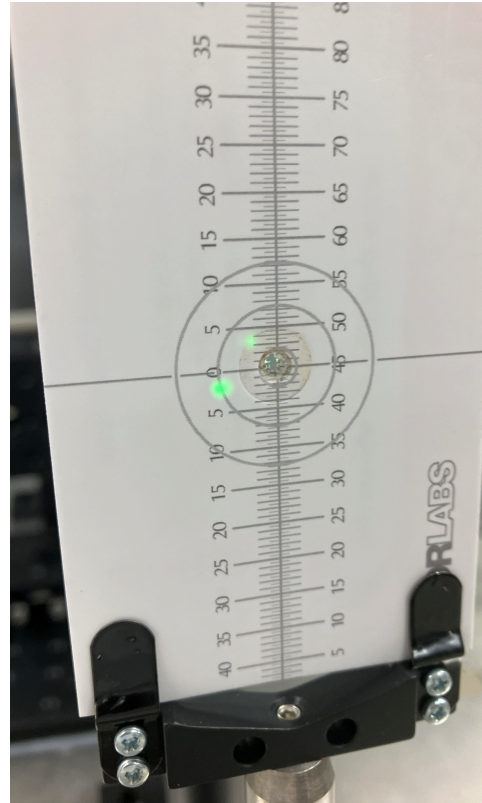

Ear up

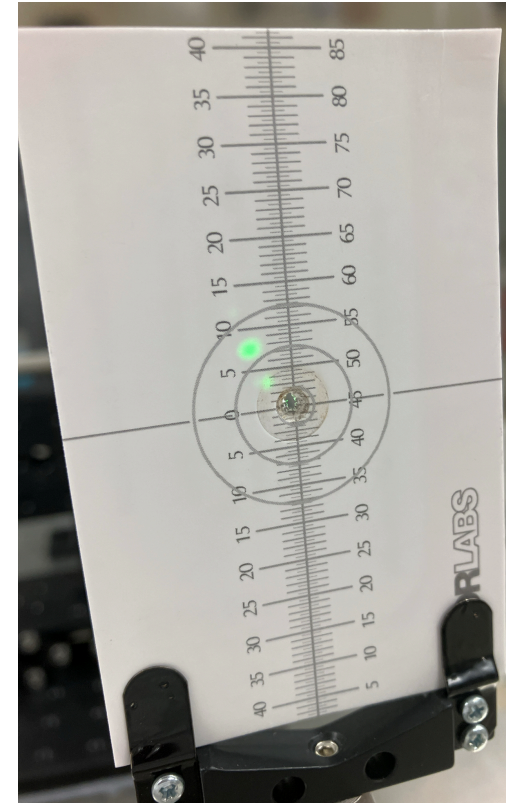

Ear to the right

# Laser colinear with R30-4 gun electrode z-axis SSL GaAs on Puck # 10

Y = 13 mm  
D = 1380 mm  
Reflection  $\theta = 0.540^\circ$

**SSL GaAs on puck # 10 z-axis angle =  $\theta/2 = 0.270^\circ$**

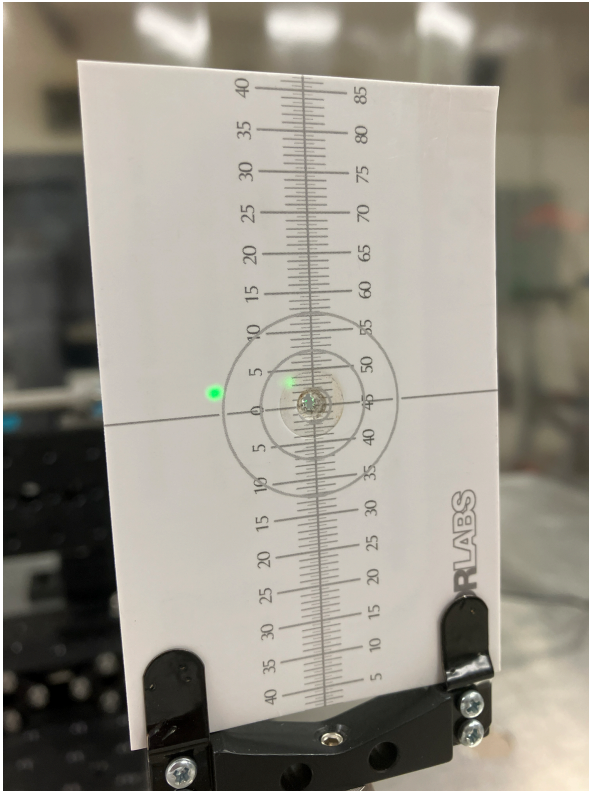

Ear to the left

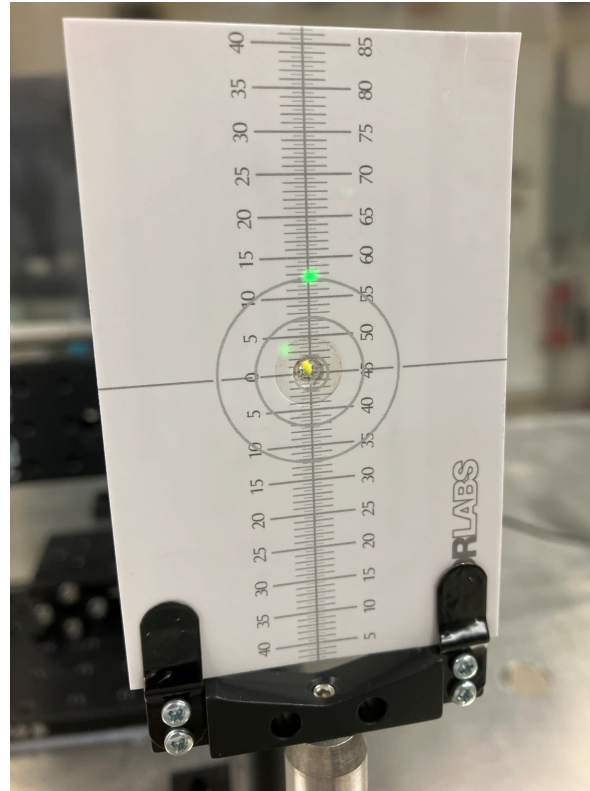

Ear up

Inadvertently I missed taking the picture with the ear to the right



Based solely on laser retro-reflection spot displacement measurements.  
the GaAs wafer plane seems to be tilted  $0.188^\circ$  down wrt to the puck z-axis

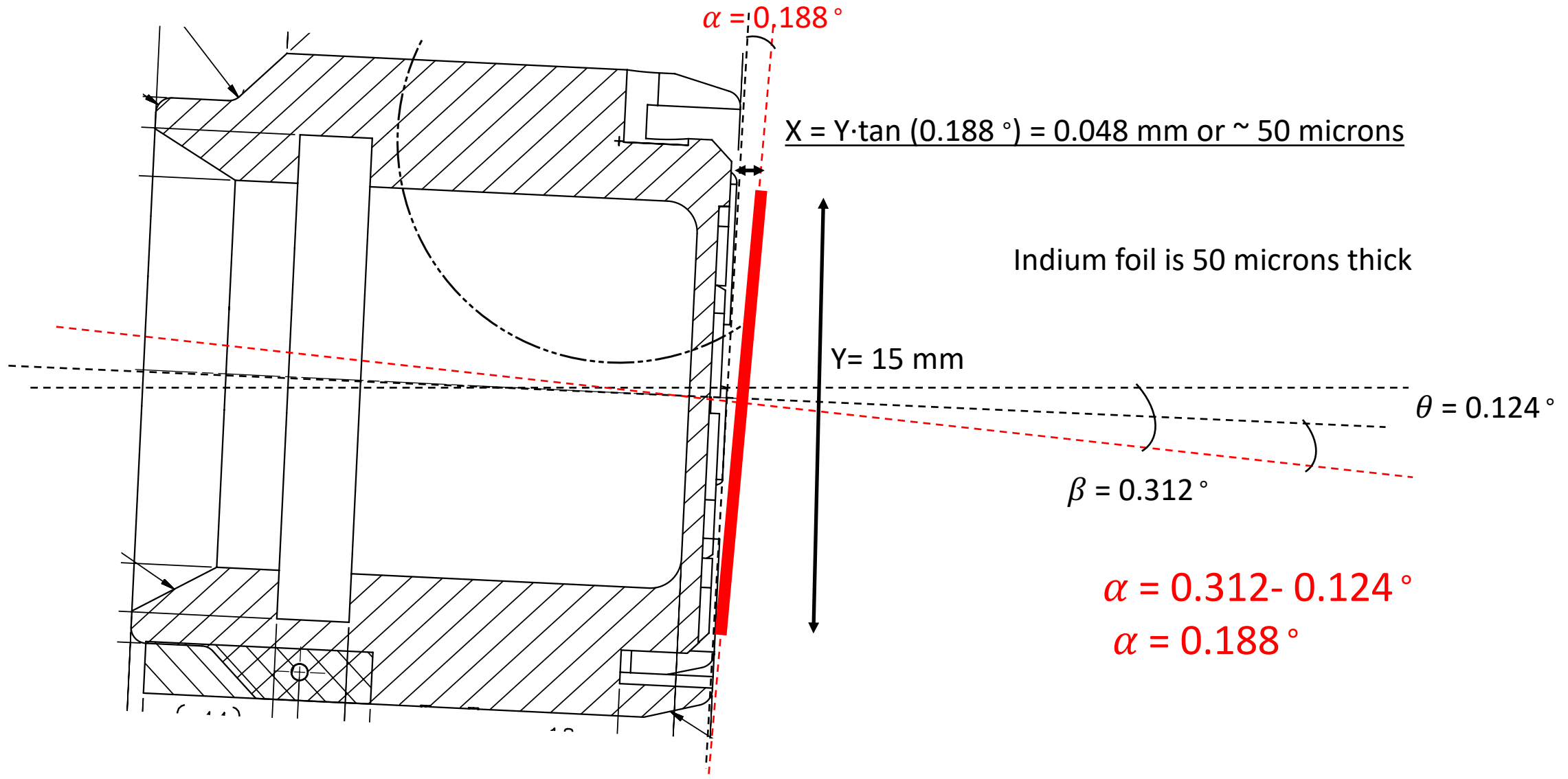

# Puck # 35 with bulk GaAs was sent to SRF Coordinate Measuring Machine (CMM)

	PART NAME : High Voltage Gun Puck Body#35 JL0047248	May 08, 2024	15:34
	REV NUMBER : RevB	SER NUMBER : CMM2	STATS COUNT : 1

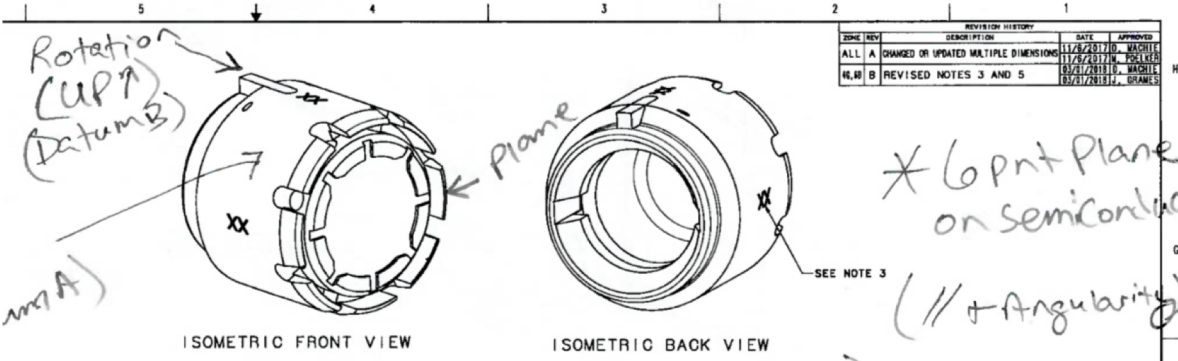
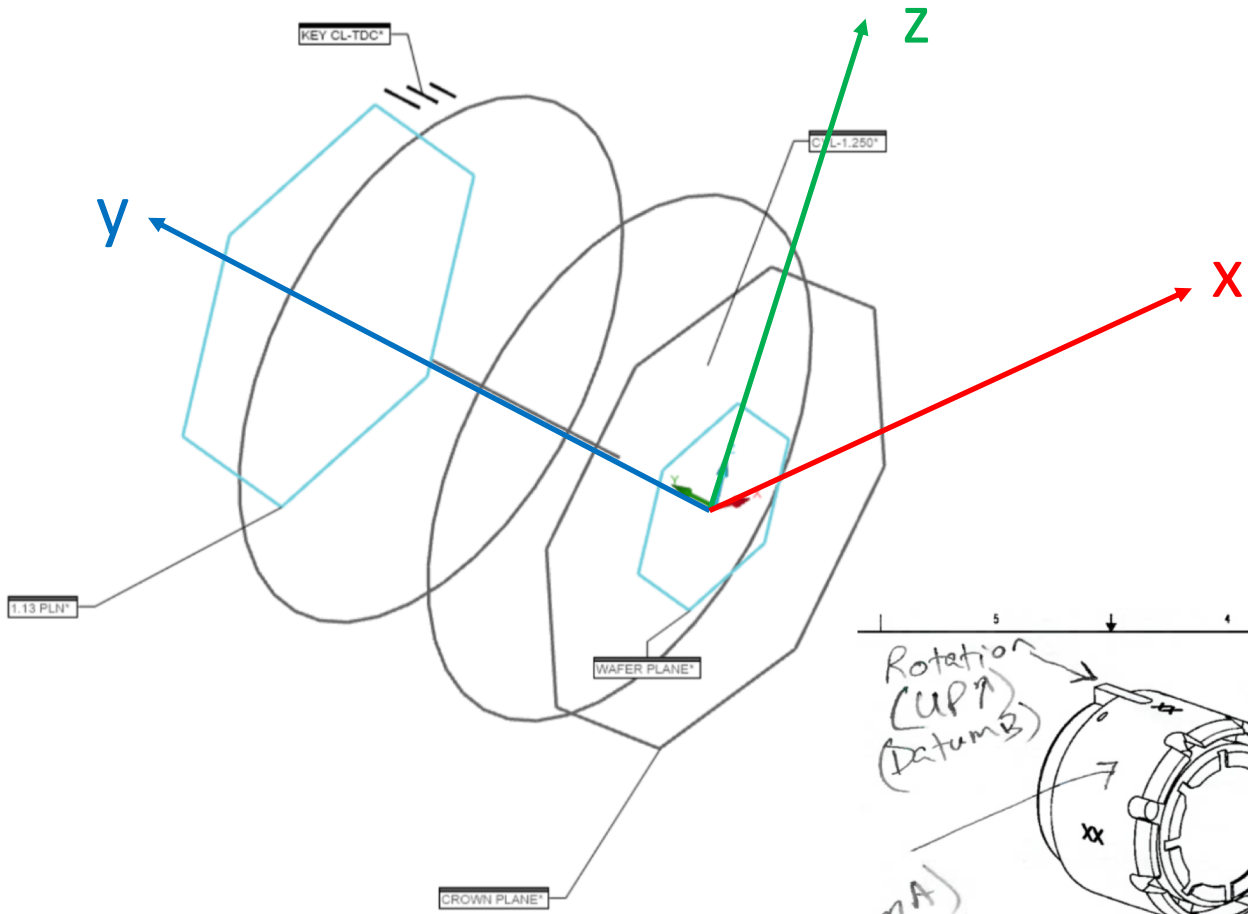

The CMM results show that:

- The crown plane is tilted up wrt the puck z-axis by 0.0574°
- The wafer plane is tilted down wrt the puck z-axis by 0.1729°

↙	DEG	ANGL2 - CROWN PLANE TO YAXIS					
AX		NOMINAL	+TOL	-TOL	MEAS	DEV	OUTTOL
A		270.0000	0.1000	0.1000	269.9426	-0.0574	0.0000
↙	DEG	ANGL4 - CROWN PLANE TO XAXIS					
AX		NOMINAL	+TOL	-TOL	MEAS	DEV	OUTTOL
A		360.0000	0.1000	0.1000	359.9918	-0.0082	0.0000
↙	DEG	ANGL6 - WAFER PLANE TO YAXIS					
AX		NOMINAL	+TOL	-TOL	MEAS	DEV	OUTTOL
A		270.0000	0.1000	0.1000	270.1719	0.1719	0.0719
↙	DEG	ANGL7 - WAFER PLANE TO XAXIS					
AX		NOMINAL	+TOL	-TOL	MEAS	DEV	OUTTOL
A		90.0000	0.1000	0.1000	89.8281	-0.1719	0.0719
↔	IN	DIST1 - 1.13 PLN TO CROWN PLANE					
AX		NOMINAL	+TOL	-TOL	MEAS	DEV	OUTTOL
M		1.1300	0.0100	0.0100	1.1325	0.0025	0.0000