

# Bubble Chamber Detector System

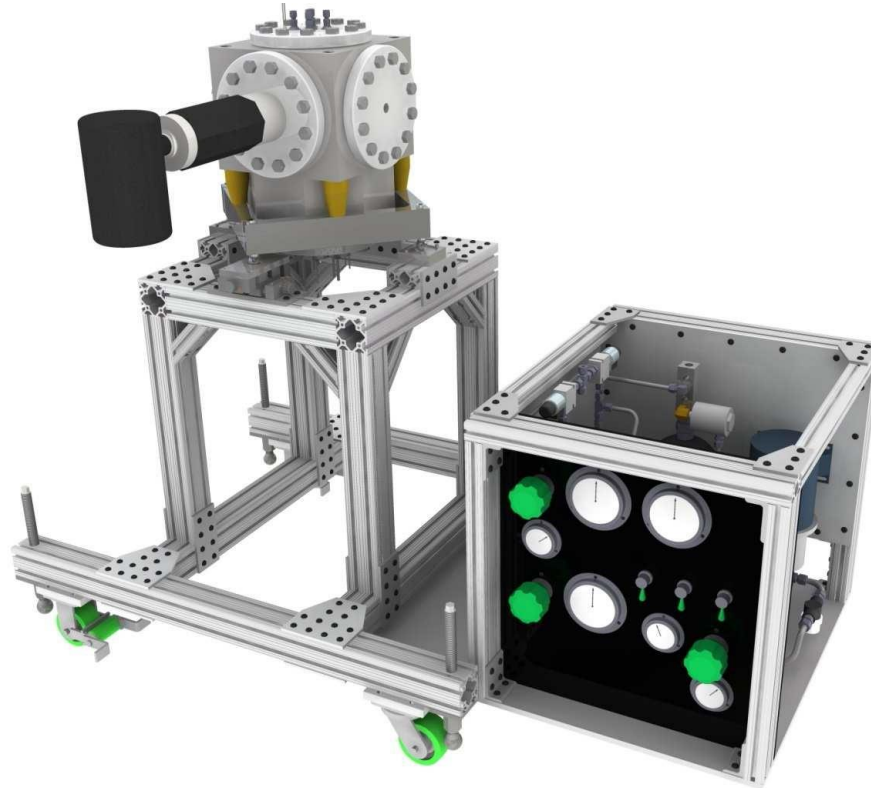

# ANL Bubble Chamber

---

- Lead designer and fabricator Brad DiGiovine (ANL)
- April 2009 Chamber Received Full Operation Authorization for (C<sub>4</sub>F<sub>10</sub>)
- February 2010 First Bubble Chamber Received Upgrade Authorization for Superheated H<sub>2</sub>O
- Two runs at HI $\gamma$ S
- Modifications: N<sub>2</sub>O with Hg as buffer fluid
- Modifications were reviewed at ANL
- Extensive testing and operations at ANL using N<sub>2</sub>O and mercury (neutron source)
- Brought to JLAB for testing with photons
  - JLAB Design Authority: Dave Meekins
  - First user built pressure system (non-vacuum) post 10 CFR 851

# Theory of Operation

- 1 Cell is cooled then filled with room temperature gas
- 2 Gas is cooled and condenses into liquid then becomes sub-cooled
- 3 Once cell is completely filled with liquid, pressure is reduced creating a superheated liquid
- 3 Nuclear reactions induce bubble nucleation
- 2 High speed camera detects bubble and repressurizes
- 3 System depressurizes and ready for another cycle

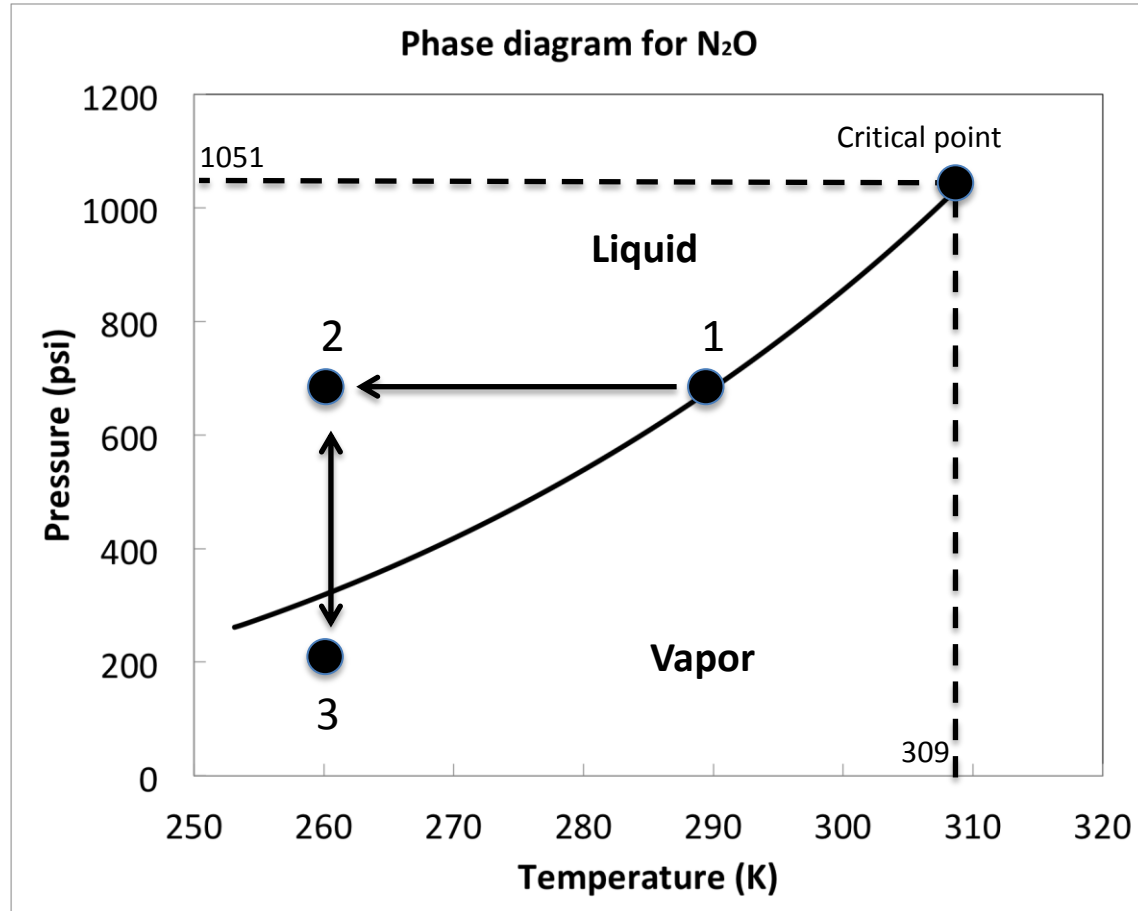

# BUBBLE GROWTH AND QUENCHING

100 Hz Digital Camera

$\Delta t = 10 \text{ ms}$

$\text{N}_2\text{O}$  Chamber  
with PuC neutron  
source

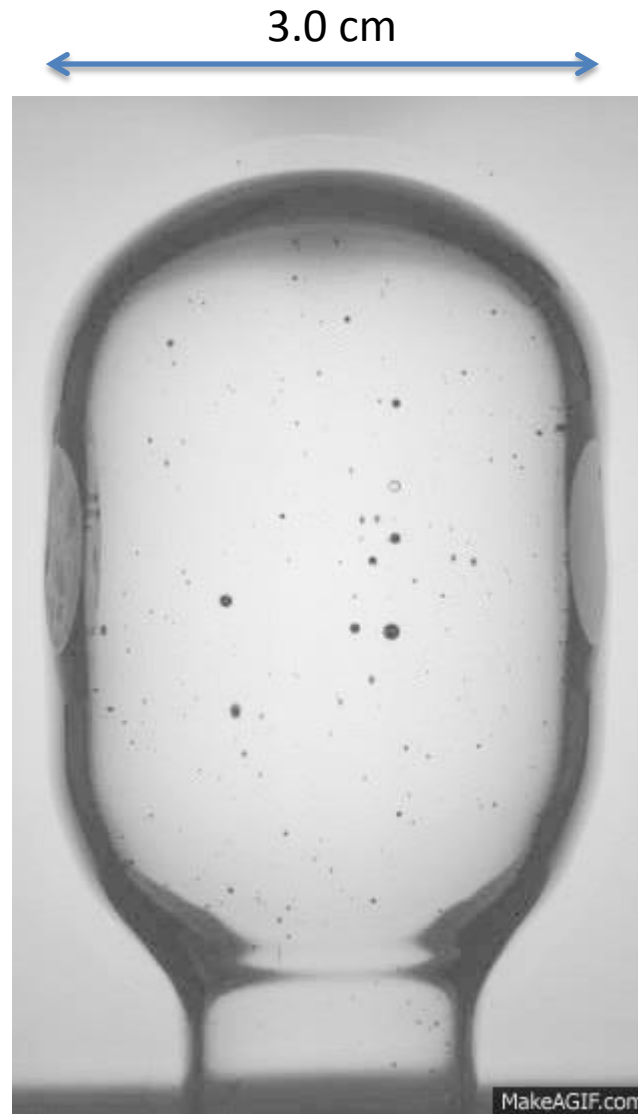

# Systems and Components

---

- Bubble Chamber
  - 40-60 ml
- Pressure Vessel
  - Max operating pressure 1000 psi
- Viewport, Camera and Lighting
- Hydraulic Control
- Cooling circuit/refrigerator
  - -20C to room temp.
- DAQ/Control and Instrumentation

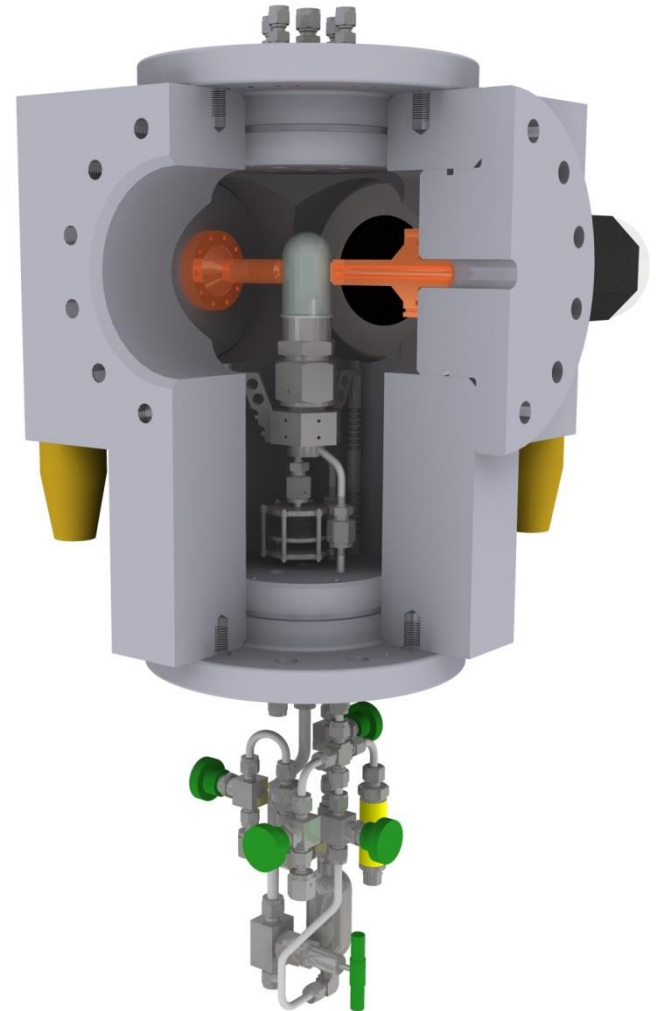

# Basic Components

- Heavy Wall Stainless Steel Pressure Vessel
- Thin Wall Glass Active Liquid Volume
- Thin Pressure Transfer Bellows
- Cooling Coils
- Pressure Supply
- Solenoid Valves
- High Speed Camera

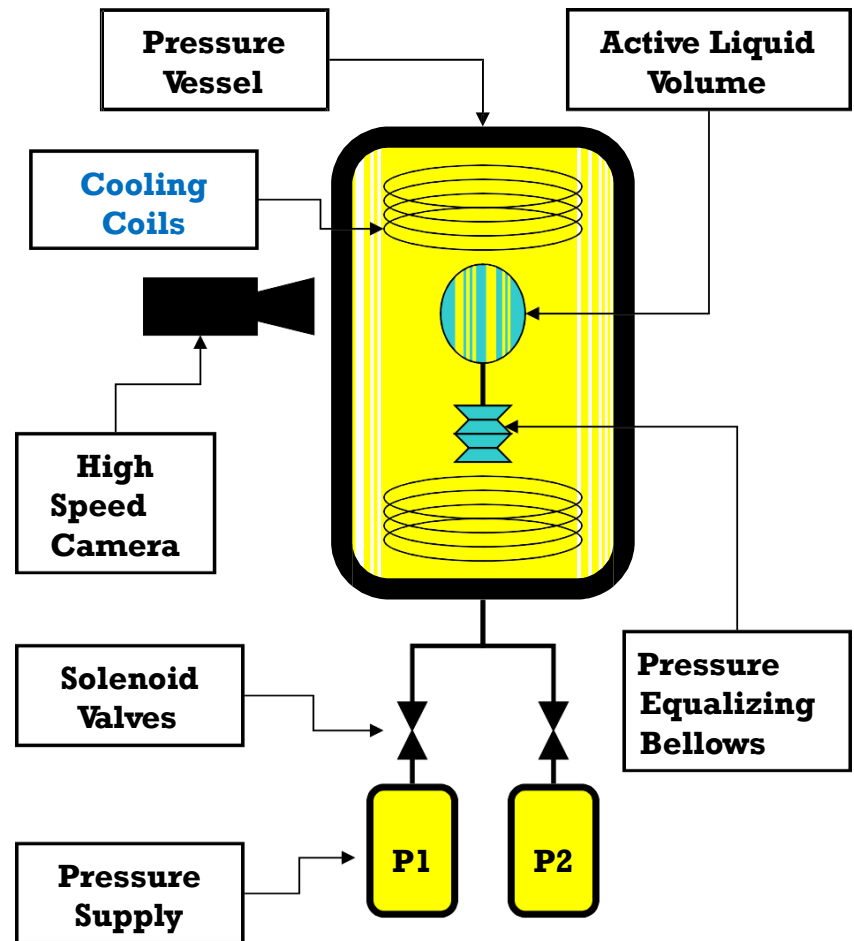

# Bubble Chamber

---



- Thin Glass Vessel Holds Active Liquid,  $N_2O$
- $N_2O$  40-60 ml Floats on Mercury 150 ml, Which Fills Remaining Inner Volume
- Superheated Liquid Only in Contact With Smooth Surfaces
- Thin Sensitive Edge Welded Bellows Equalize Pressure
- Stainless Tube Facilitates External Connection of Pressure Transducers and Filling Valves
- **Wetted Materials: Stainless Steel, Kovar, Glass**
- Copper cooling coils (not shown) supplied by commercial refrigerator.

# Pressure Vessel

---

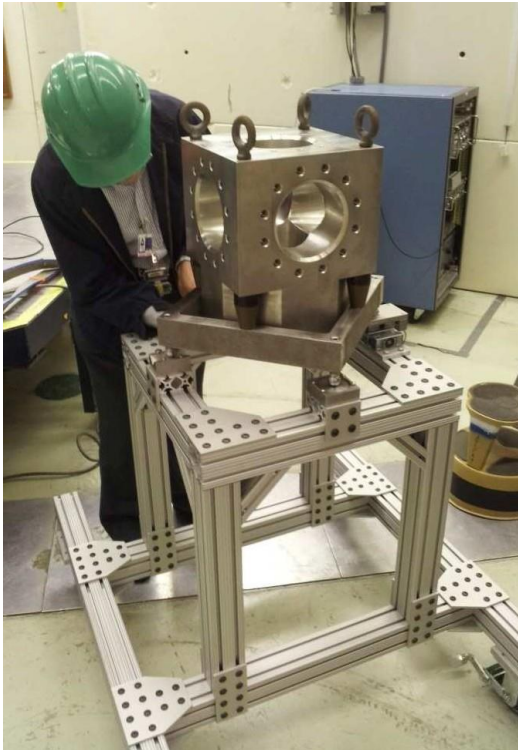

- Houses Bubble Chamber
- One Piece Construction
  - No Welding
  - Minimal Internal Volume
- Machined From a Solid 304 S.S. Forging
- Flanges Machined From 316 S.S.
  - Utilize a Plug Design to Reduce Inner Volume
- Maximum allowable design pressure 1700 psi.
  - Component has 5.75" bore
  - Treated as B31.3 (using 304.7.2)
  - Div 2 analysis using elastic plastic
    - Plastic collapse/local failure
  - Fatigue screening indicates cycles required to squish bubbles not deep enough to consider for 500 psi  $\Delta P$  maximum. Div 2 Part 5.5.2.4



# Viewport, Camera, and Lighting



- Two Custom Designed and Fabricated by Industry Leader in High P&T Viewports
- Design Parameters:
  - 260°C Operating temperature
  - 88 ATM (1300 psi) Operating pressure
- One Houses High Speed 100FPS Camera
- One Houses High Intensity LED Back Lighting

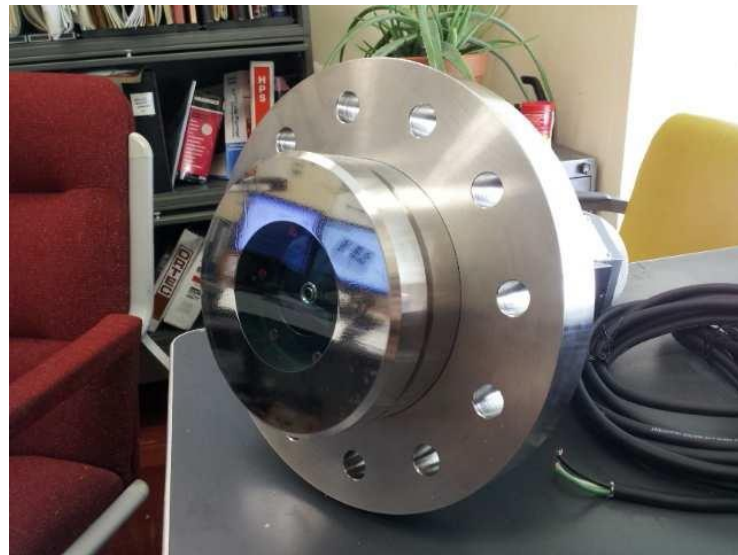

# Hydraulic Control System

- Constructed of standard fittings and components with minimum working ratings of 1500 psi.
- Piping is SST tube and flex lines with lowest design P=2500 psi
- Accumulators are charged with N2 circuit design P=1000 psi
- Pump supplies 1 gpm
- Multiple hydraulic regulators and reliefs
- Vented reservoir
- Screened for cyclic loading



# Hydraulic Control System

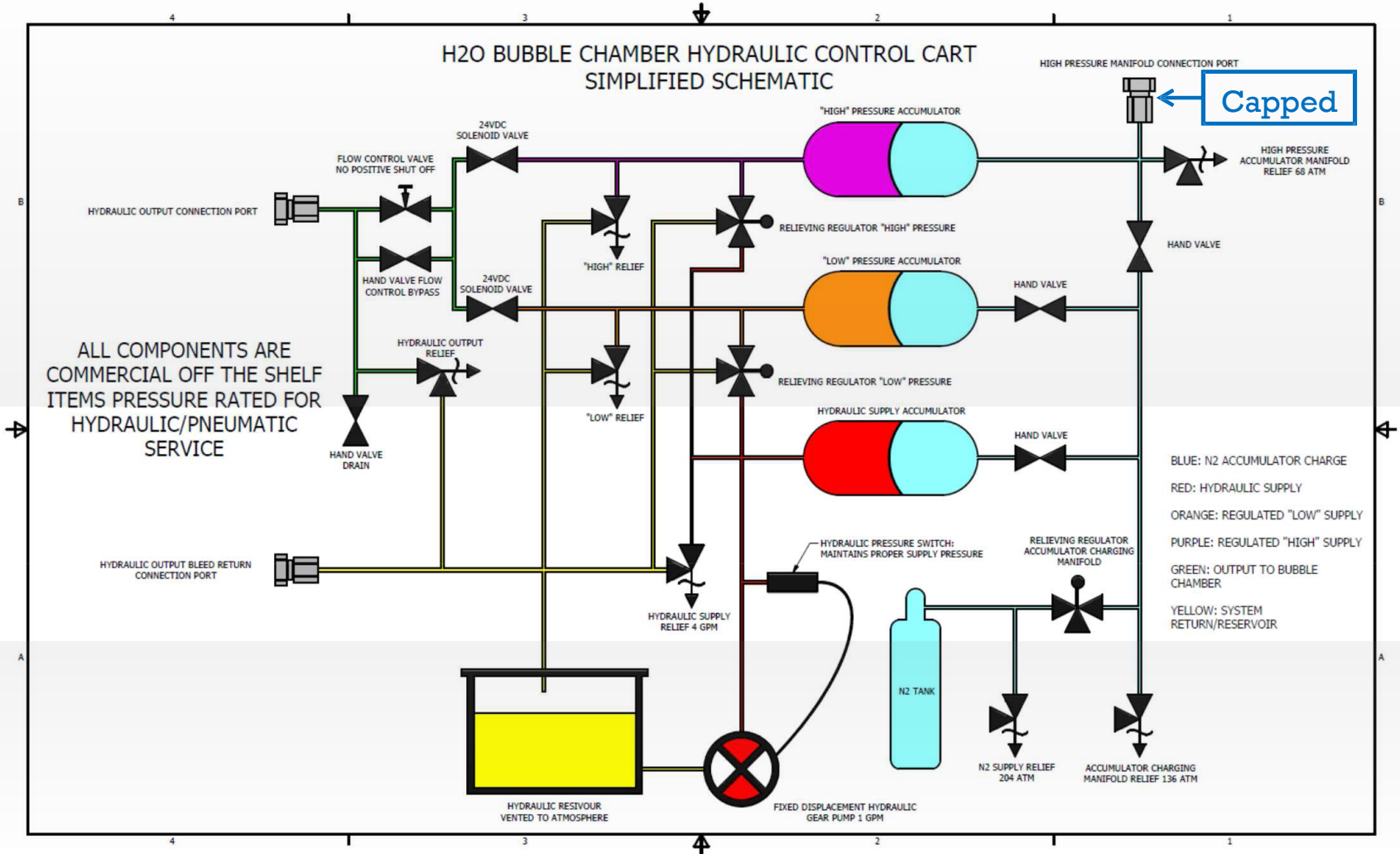

# Overpressure Protection

- Two separate circuits
- Sources of overpressure
  - Fire (not considered)
  - Pump run away
- N2 circuit
  - ASME relief directly on bottle
  - Orifice restricted flow to system piping
  - 1000 psi ASME relief with adequate flow capacity
- Hydraulic circuit
  - Multiple hydraulic reliefs non ASME below 1000 psi.
  - ASME relief on chamber 1100 psi (12.7 gpm)
  - N2O is liquid at room temp at this pressure
- Detailed in TGT-CALC-502-003

# JLAB/ANL Pressure Program

JLAB	Argonne
Calculations must follow Code	Calculations follow good practice
Leak/pressure test must be formally documented	A pressure test was performed and documented in logbook
Overpressure protection must follow UG-125-140 (ASME)	Relief must be supplied
Quality program requires documented materials (above Code requirements)	Materials must be procured as specified
Examinations must be formally documented	

# HazMat

- Two materials of note:
  - Mercury (Hg)
  - Nitrous Oxide (N<sub>2</sub>O)
- Admin and Eng controls in place
  - Procedures for filling/operating/venting
  - Hg not “handled” at JLAB under normal conditions
  - Volume of N<sub>2</sub>O in chamber is 17 liters at STP
  - Filters are in place to prevent Hg liquid and vapor from escaping confinement.

# Mercury

- Prolonged or intense acute exposure can be very hazardous.
- Active fluid is removed through
  - Phase separator
  - Droplet Filter
  - Vapor Filter
- This prevents Hg from escape.
- There is secondary containment under the chamber should a mistake occur
  - Two step error: Removing VCR Cap and opening valve
- Monitor personnel for exposure using SKC Elemental Mercury Passive Sampler.
- IH to monitor filling/venting
- Filling and venting procedures shall only be performed by Brad DiGiovine (ANL).
- Spill kit on hand to properly respond in the event of containment loss

# N2O

- Occupational exposure limit of 50 ppm
  - 2000 hr/year
- If all in chamber is released to injector -> 25 ppm
- Monitor personnel for exposure using Assay Technology 575 N2O sampler.
- IH to monitor filling/venting
- Filling and venting procedures shall only be performed by Brad DiGiovine (ANL).
- Supply bottle is removed immediately after fill procedure is complete. (Total of 17 STPL in injector)



# Electrical Safety

- System requires 208VAC power
- Custom components were developed by ANL
  - Detailed schematics can be found in pressure systems folder
  - The system was inspected by both ANL and JLAB
- All components can be disconnected from the power source with plug and secured.

# Cooling

---

- Heavy Wall Copper Cooling Coils Installed
- Bath Operating Temperature -20C to 20C

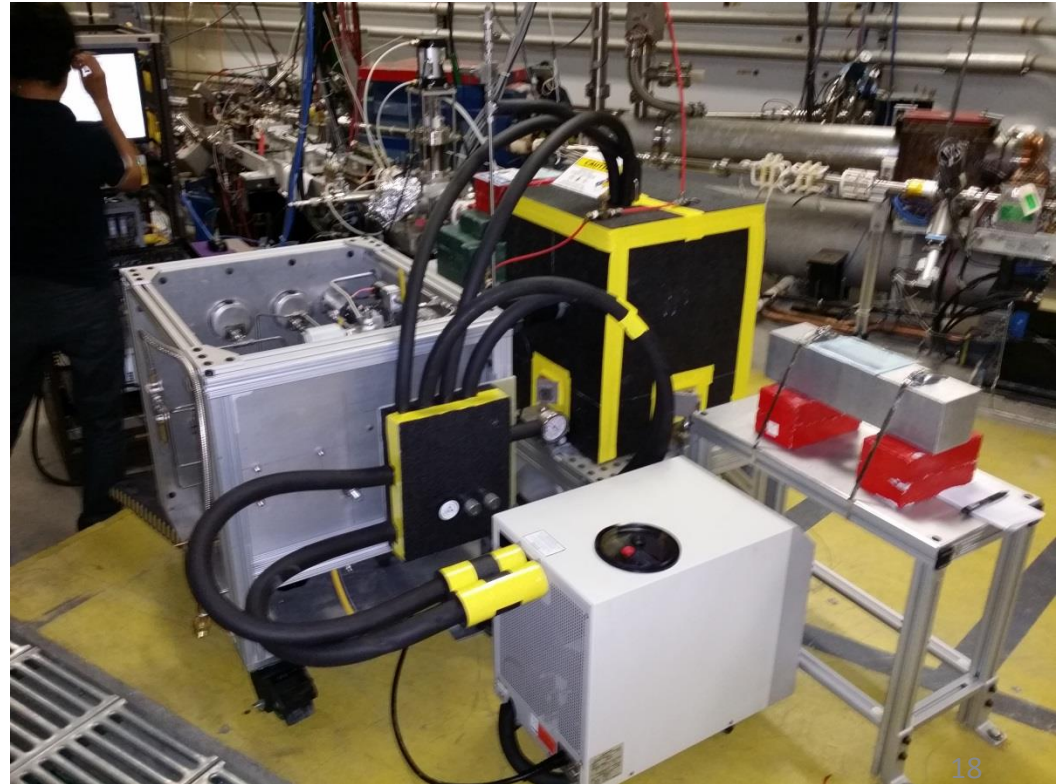

# Control and Instrumentation Chassis

- Temperature Monitoring and Heater Control
- Pressure and Temperature Transducer Retransmission to Computer
- Solenoid Valve Manual Operation and Computer Interface
- Hydraulic System Logic and Interlocks
- Two Remote Override Control Interfaces
- Electrical Safety Inspection Completed on All Chasses

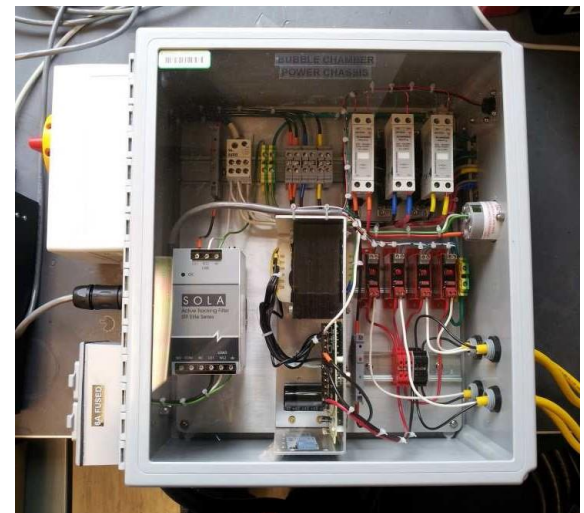

# Control Chassis & Remote Overrides

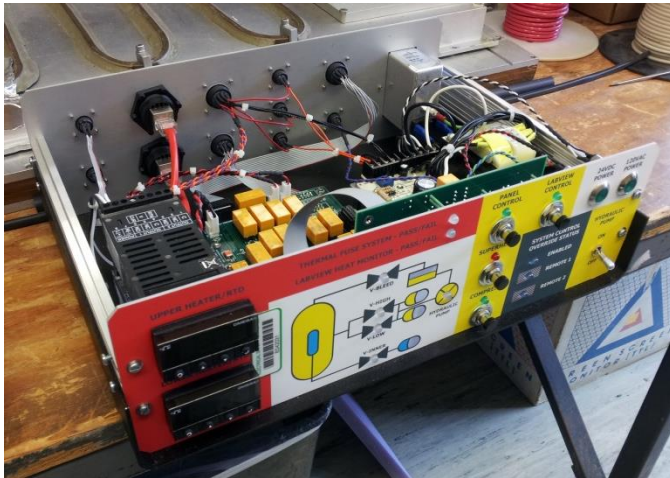

- Control Chassis Designed with Safety Interlocks
  - Heating
  - Solenoid Valves



- Two Remote Override Interfaces Allow for Complete Control of System
  - Solenoid Valves
  - Hydraulic Pump
  - Heaters

# Detector Control Rack



# Failure Modes and Effects

- Failure of glass bubble chamber
- Failure of pump cut off switch
- Accumulator failure
- Regulator failure
- Refrigerator failure
- Power failure

# Failure of glass bubble chamber

- Failure can be detected by camera remotely or by direct observation.
- N<sub>2</sub>O (or C<sub>2</sub>F<sub>6</sub>) and Hg may be released into hydraulic fluid.
- The integrity of the system is not lost.
- The fluid mix can be drained back to reservoir and shipped back to ANL for recovery.

# Failure of Pump Cut off

- Pump is controlled by pressure switch
  - Failure causes pump to run continuously at 1 gpm
- Multiple relief devices and control regulators will relieve pressure/excess flow back to reservoir
- ASME relief set at 1100 psi will blow down entire system should other relief paths fail.
- $\Delta P$  across glass will stay low due to equalizing bellows



# Accumulator Failure

- This mode is considered very unlikely due to working pressure rating 3x higher than operating
- Accumulators are diaphragm style.
- There will be DAQ and control issues but system integrity will be maintained.
- $\Delta P$  across glass will stay low due to equalizing bellows

# Regulator Failure

- N2 regulator failure only affects accumulator filling actions. This is very rare.
- Orifice limits flow and ASME relief with excess capacity is set at 1000 psi.
- N2 bottle is disconnected after charging the accumulators

# Refrigerator Failure

- DAQ system will alarm unless full power failure.
- Interlocks will open CV-1 (high pressure valve) and close CV-4 (low pressure valve).
- Active fluid will stay in liquid state while system warms to room temperature
- No damage will occur to bubble chamber.
- System expert shall address issues and repair as needed.

# Power Failure

- During power failure DAQ, control, pump and refrigerator stop
- CV-1 opens (default state) and CV-4 closes (default state)
- Chamber is returned to high pressure “standby” mode which is stable.
- The system will slowly warm.
- The system will stay down until reset
- Only system expert may perform reset.

# Required Training

- To operate the detector users shall be trained by Brad DiGiovine
- Only system expert shall perform fluid handling procedures or adjustments to controls
- SAF 801 Rad worker I
- SAF 103 ODH
- SAF 130 Oil Spill Training (not required for all personnel and only if needed)
- SAF 132 Tunnel worker safety
- SAF 801kd RWP for tunnel access
- SAF 100 General safety

# Operating Procedures

- Following procedures are developed
  - Fill procedure
  - Venting
  - Power loss
  - Fire (leave area call 911)
  - Basic user operation
    - Start/stop runs
    - Only available after system is placed in standby mode by expert
  - DAQ failure procedure
- Emergency de-energize procedure is available for all personnel but, will require that the system be shipped back to ANL for repair.

# User Interface



# Running Adjustments

- Test is to understand and optimize the detector performance.
- Only system expert shall make/approve changes to the fluid system
- Possible adjustments include
  - Operating pressure/temperature
  - Quench pressure
  - Fluid levels
  - Dead time