

Person: Hernandez-Garcia, Carlos ([chgarcia@jlab.org](mailto:chgarcia@jlab.org))  
 Org: ACCCIS

Status: PROCESSED

Saved:

Submitted: 12/17/2013 10:08:56 AM



Operational Safety Procedure Review and Approval Form # 33223  
 (See [ES&H Manual Chapter 3310 Appendix T1 Operational Safety Procedure \(OSP\) and Temporary OSP Procedure](#) for Instructions)

Type:

**OSP** [Click for OSP/TOSP Procedure Form](#)  
[Click for LOSP Procedure Form](#)

Serial Number:

**FEL-14-33223-OSP**

Issue Date:

**1/6/2014**

Expiration Date:

**10/6/2016**

Title:

**GTS 600 kV Gas Insulated Power Supply Maintenance & Safety**

Location:  
 (where work is being performed)

**Low Energy Recovery Facility (LERF) - 109A**

Location Detail:  
 (specifics about  
 where in the selected  
 location(s) the work  
 is being performed)

**Inside the  
 FEL's GTS  
 (Gun Test  
 Stand) vault**

Risk Classification:

Without mitigation measures (3 or 4):

**4**

(See [ES&H Manual Chapter 3210 Appendix T3 Risk Code Assignment](#))

With mitigation measures in place (N, 1, or 2):

**1**

Reason:

This document is written to mitigate hazard issues that are :  
**Determined to have an unmitigated Risk code of 3 or 4**

Owning Organization:

**FEL**

Document Owner(s):

**Hernandez-Garcia, Carlos ([chgarcia@jlab.org](mailto:chgarcia@jlab.org)) Primary**  
**Powers, Tom ([powers@jlab.org](mailto:powers@jlab.org))**

Supplemental Technical Validations

**Toxic Agents (Dick Owen, Jennifer Williams)**

**50V or Greater: Diagnostic Type Operations (Paul Powers, Todd Kujawa)**

**Gas (Dick Owen, Jennifer Williams)**

**Pressurized Tanks, Containers, and Vacuum Vessels (Dave Meekins, Kelly Dixon, Timothy Whitlatch, Will Oren)**

**Sources-Prompt Radiation & Induced Radioactivity (Keith Welch, Vashek Vylet)**

Document History

Revision	Reason for revision or update	Serial number of superceded document
	<b>Update and renewal of preceding document</b>	<b>FEL-10-053-OSP</b>

Comments for  
 reviewers/approvers:

**The Rev02 document incorporates Will Oren's correction to section 4.4, just added SAF130A training to the list. No other changes have been made to other sections that reviewers have already signed off in Rev01.**

Attachments

Procedure: *GTS HVPS OSP Dec\_2013-Rev02.pdf*

THA: *THA GTS 600kV HVPS Dec 2013.pdf*

Additional Files:

[Convert to PDF](#)

Review Signatures

Subject Matter Expert : Chemicals->Toxic Agents	<b>Signed</b> on 12/18/2013 9:10:26 AM by Jennifer Williams ( <a href="mailto:jennifer@jlab.org">jennifer@jlab.org</a> )
Subject Matter Expert : Electricity->>50 amps OR >50 Vac OR 60Vdc AND >5 mA	<b>Signed</b> on 12/17/2013 10:51:44 AM by Todd Kujawa ( <a href="mailto:kujawa@jlab.org">kujawa@jlab.org</a> )
Subject Matter Expert : Oxygen Deficiency Hazards (ODH)->Gas	<b>Signed</b> on 12/18/2013 8:35:13 AM by Dick Owen ( <a href="mailto:rowen@jlab.org">rowen@jlab.org</a> )
Subject Matter Expert : Pressure Systems->Pressurized Tanks-> Containers-> and Vacuum Vessels	<b>Signed</b> on 12/17/2013 10:11:05 AM by Will Oren ( <a href="mailto:oren@jlab.org">oren@jlab.org</a> )
Subject Matter Expert : Radiation - Ionizing->Sources-Prompt Radiation & Induced Radioactivity	<b>Signed</b> on 1/2/2014 12:48:39 PM by Vashek Vylet ( <a href="mailto:vylet@jlab.org">vylet@jlab.org</a> )

Approval Signatures

Division Safety Officer : FEL	<b>Signed</b> on 1/3/2014 10:53:02 AM by Steve Benson ( <a href="mailto:felman@jlab.org">felman@jlab.org</a> )
Org Manager : FEL	<b>Signed</b> on 1/6/2014 8:45:51 AM by George Neil ( <a href="mailto:neil@jlab.org">neil@jlab.org</a> )
Safety Warden : Free Electron Laser (FEL) - 109A	<b>Signed</b> on 1/6/2014 8:39:11 AM by Jason Delk ( <a href="mailto:delk@jlab.org">delk@jlab.org</a> )

**Operational Safety Procedure Form**  
 (See [ES&H Manual Chapter 3310 Appendix T1](#)  
**Operational Safety Procedure (OSP) and Temporary**  
**OSP Procedure for instructions.**)

Click  
For Word Doc

**DEFINE THE SCOPE OF WORK**

<b>Title:</b>	GTS 600 kV Gas Insulated Power Supply Maintenance & Safety		
<b>Location:</b>	FEL Building 18, Room 109A (AKA GTS vault)	<b>Type:</b>	<input checked="" type="checkbox"/> <b>OSP</b> <input type="checkbox"/> <b>TOSP</b>
<b>Risk Classification</b> (per <a href="#">Task Hazard Analysis</a> attached) (See <a href="#">ESH&amp;Q Manual Chapter 3210 Appendix T3 Risk Code Assignment.</a> )	<b>Highest Risk Code Before Mitigation (3 or 4):</b>		4
	<b>Highest Risk Code after Mitigation (N, 1, or 2):</b>		1
<b>Document Owner(s):</b>	Carlos Hernandez-Garcia	<b>Date:</b>	December 17, 2013
<b>Document History (Optional)</b>			
<b>Revision:</b>	<b>Reason for revision or update:</b>	<b>Serial number of superseded document</b>	
	Updating document	FEL-10-053-OSP	

**ANALYZE THE HAZARDS**

**1. Purpose of the Procedure** – Describe in detail the reason for the procedure (what is being done and why).

Provide safe working conditions to allow:

- a) Normal operations, and
- b) Maintenance / repairs

of the Gun Test Stand (GTS) 600 kV gas insulated High Voltage Power Supply (HVPS).

**2. Scope** – include all operations, people, and/or areas that the procedure will affect.

This document covers the normal operation and safety procedures for the GTS 600 kV gas insulated HVPS. When repairs/maintenance to the GTS 600kV HVPS are needed, this document is to be used in conjunction with the Glassman power supply instruction manual.

**3. Description of the Facility** – include floor plans and layout of a typical experiment or operation.

The GTS 600kV HVPS is located in the GTS vault, room 109A FEL Building 18. The Remote Control Unit or chassis, for the GTS 600kV HVPS is located on the floor above the GTS vault in room 217 rack GL01B02. A layout of room 109A is shown below.

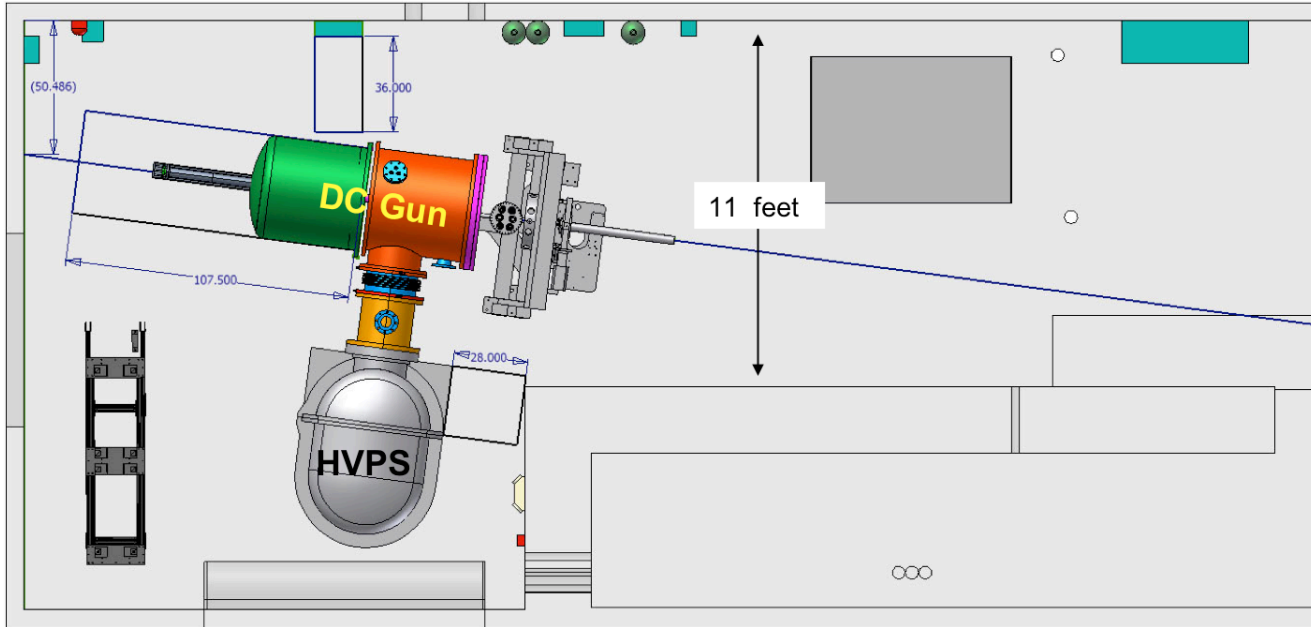

All dimensions in inches unless marked otherwise

#### 4. Authority and Responsibility:

##### 4.1 Who has authority to implement/terminate

George Neil, or Steve Benson.

##### 4.2 Who is responsible for key tasks

Carlos Hernandez-Garcia is responsible for training and qualifying personnel on normal operations of the 600kV HVPS. The qualified personnel are responsible for performing normal operations safely and properly. Normal operations include:

- a) Connecting the HVPS to the DC electron gun
- b) Pumping down and backfilling the HVPS tank with SF6 for normal operations, and
- c) Standard operations remotely performed via EPICS of the HVPS connected to the DC electron gun.

Tom Powers is responsible for training and qualifying electrical technicians on the equipment. The qualified electrical technicians are responsible for performing maintenance/repair tasks safely and properly. This tasks may involve working with electrical circuits in the remote control unit, the input drive, and/or the Cockcroft-Walton (C-W) voltage multiplier.

##### 4.3 Who analyzes the special or unusual hazards (See [ES&H Manual Chapter 3210 Appendix T1 Work Planning, Control, and Authorization Procedure](#))

Ionizing Radiation -	V. Vylet
High Voltages (AC & DC) -	T. Kujawa
Pressure Vessel -	W. Oren
Oxygen Deficiency Hazards -	R. Owen
Environmental -	J. Williams

##### 4.4 What are the Training Requirements (See [http://www.jlab.org/div\\_dept/train/poc.pdf](http://www.jlab.org/div_dept/train/poc.pdf))

Regardless if the task is normal operations or maintenance/repairs, all personnel working with the GTS 600kV HVPS supply must have the following training:

- SAF100 ES&H Orientation
- SAF103 Oxygen deficiency hazard
- SAF104 Lock, tag and try
- SAF130A Pressure systems awareness
- SAF143kd FEL Safety awareness
- SAF603A Electrical Safety Awareness
- SAF603N1 Arc Flash Safety Awareness
- SAF603N2 Electrical Emergencies Proper Response
- SAF603N3 Electrical Safety for Qualified Worker
- This document

Maintenance and trouble-shooting of any of the circuits must be performed by qualified personnel, and only after a FEList is approved for the task. The FEList entry will notify the Division Safety Officer and the System Owner. Two persons are needed to safe out the GTS 600kV HVPS. Each person rendering the HVPS safe must be properly trained and qualified as given above.

## 5. Personal and Environmental Hazard Controls Including:

### 5.1 Shielding

Except for the Remote Control Unit, all operating equipment is contained inside a metal cabinet or tank, inside the locked vault. The Remote Control Unit is located in a metal rack, which has no exposed wiring. The metal cabinet, tank, and vault are the shields for any ionizing radiation. A gas pressure-sensing interlock keeps the HVPS from turning ON if the tank is below 5 psi of instrument air or SF<sub>6</sub>, therefore preventing ionizing radiation, which is only possible if voltage is present in vacuum conditions.

### 5.2 Interlocks

A position-sensing switch is installed on the HVPS tank entry door and a gas pressure-sensing switch is installed on the HVPS tank. These sensors are connected into redundant power supply interlock circuits. The first circuit is the normal power supply control circuitry external interlock connection. The second circuit is an independent AC contactor placed in the input 208 VAC power feeding the power supply. These interlocks are enunciated and latched by a fault-indicating panel in the control room.

Whenever the power supply is connected to an electron gun, the GTS Personal Safety System (PSS) and the gun vacuum interlocks must also be connected into the power supply interlock control chains.

### 5.3 Monitoring systems

A Voltage Verification Unit (VUU), mounted on the south wall of room 217 near the rack housing the Glassman HVPS Remote Control Unit, monitors the 208 VAC power coming into the HVPS. The VUU is wired just downstream of the power supply 208 VAC disconnect Switch. The VUU is used to verify that indeed the 208 VAC has been disconnected from the power supply. A pressure sensor, located on the side of the HVPS tank, monitors the pressure of the SF<sub>6</sub> or instrument air in the tank. The output of the pressure sensor is also available in the gun HVPS EPICS control screen.

## 5.4 Ventilation

The GTS vault is part of the air conditioning system of the FEL vault. When the air conditioning system is running, any SF<sub>6</sub> spill or leak would be quickly dispersed due to the high flow rate of the air conditioning system. When the air conditioning system is off, any SF<sub>6</sub> would drain out of the GTS vault through the air conditioning recovery port and into the rear stair well of the FEL vault and then into the FEL vault. ODH sensors are in the GTS vault, rear stair well, and at collection points in the FEL vault. The Safety System Group electronics continuously monitor the ODH sensor.

## 5.5 Other (Electrical, ODH, Trip, Ladder) (Attach related Temporary Work Permits or Safety Reviews as appropriate.)

### A PROMPT IONIZING RADIATION:

#### Primary Hazard (A1) Risk Code 3

Exposure to prompt radiation (X-rays) in excess of 0.05 mR/hr at 30 cm.

When the high voltage power supply is connected to the GTS photocathode gun, the gun will produce significant amounts of relatively hard X-rays.

#### Primary Hazard (A1) Mitigation Risk Code 1

The photocathode gun contains the components in vacuum that may produce the radiation and is covered under a separate work control document.

The FEL Personnel Safety System (PSS) provides primary mitigation for the photocathode gun. When the GTS HVPS is connected to the gun photocathode, no one will be allowed to enter the GTS enclosure while the HVPS is energized. The PSS interlock system is connected to the HVPS control system with two redundant shut down schemes. This is the normal mode of operation for the Gun Test Stand.

However, during normal maintenance of the HVPS, it may be required to energize the HVPS under "local" control, with people present. Under these conditions, the HVPS output conditioning resistor must be removed from between the photocathode gun and the HVPS, prior to enabling the HVPS. In this configuration, it is safe to operate the HVPS components or the entire HVPS with the PSS system connection by-passed.

**NOTE** - Members of the JLab Safety System group are the only JLab staff authorized to reconfigure the PSS. A PSS Jumper Request is required.

**WHEN THE POWER SUPPLY IS CONNECTED TO THE PHOTOCATHODE GUN, THE PSS INTERLOCKS MUST NEVER BE BY-PASSED.**

### B HIGH VOLTAGE, DC:

#### Primary Hazard (B1) - Risk Code 4

Injury or death may result from interaction with high DC voltages.

The 600 kV produced by the power supply system is a serious hazard, even with the power supply

maximum output current factory-limited to 5 mA. This is a Class 3, Mode 2 Hazard.

The power supply generates a 12 kV square wave at a frequency of 26 k Hz. This is the input drive to a stack containing 48 stages of **voltage-multiplying capacitors**. The stack stores about **8 Joules** of electrical energy when the HVPS is operating at 600 kV. These capacitors, when charged can be a **significant hazard** and **require about 1 minute to discharge to a safe value** through the normal bleeder and metering resistors.

### Primary Hazard (B1) Mitigation - Risk Code 1

The HVPS and Gun tanks shall not be opened for at least 1 minute after the HVPS has been turned off. The time needed to open either of the HVPS or Gun tanks is about 45 minutes. The power supply is only operated inside the pressure tank and has many large bolts that must be removed to gain access to the power supply inside. This engineering constraint of the system is adequate to ensure workers cannot come in contact with the stored electrical energy before it's had an opportunity to bleed off.

Interlocks are provided to ensure the pressure tank door is closed during normal operation of the power supply. A pressure-sensing switch is also installed to ensure the tank is pressurized before the high voltage is energized. These interlocks are independent from the PSS system and are tied directly to the HVPS interlock system.

In the Test and Maintenance mode, the HVPS may be operated as an open unpressurized system. The area around the open tank door is roped-off and Danger High Voltage signs are posted, ensuring that access is restricted and safe for the tests. If operated in air, the HVPS voltage is limited to about 150 kV by corona and if used with the Test Resistor Water Load to about 30 kV.

Prior to performing work within the high voltage tank, transmission line, or photocathode gun, workers wearing safety glasses shall attach the appropriate grounding hook to discharge any remaining energy stored in the HVPS or Gun. Whenever practicable, the grounding hook or probe shall remain in place during Test and Maintenance mode to prevent accumulation of energy.

The 12 kV square-wave fed to the multipliers is enclosed in 40 kV insulated wires, with additional vinyl tubing over each of these wires. This connection is only a few feet long and has a protective barrier.

### Secondary Hazard (B2) - Risk Code 3

Injury from involuntary reaction to electrical shock.

### Secondary Hazard (B2) Mitigation - Risk Code 1

See Hazard Mitigation (B1).

## C GAS PRESSURIZED TANK:

## Primary Hazard (C1) - Risk Code 4

Injury may result from flying debris if the HVPS tank, transmission line, or supply system should experience a failure that leads to a rupture of one of these pressure tanks. Injury is also possible from the bolts securing the tank cover and flanges, if the bolts are improperly installed or some of the bolts are left out, causing the bolts to fracture.

## Primary Hazard (C1) Mitigation - Risk Code 1

The HVPS tank, transmission line, and photocathode gun system are not considered to be a pressurized vessel per ASME Boiler & Pressure Vessel Code - Sec. VIII, since it will not be pressurized over 15 psig. The HVPS tank and piping system includes a 13 psig pressure relief valve to prevent system overpressure, two externally mounted pressure gauges, and system control valves. The relief valve was made and tested by an ASME qualified company to be fully open at 14 psig.

The HVPS tank was designed, built, tested, and stamped by the manufacturer as if it were going to be a pressure vessel. The tank and its components have been hydrostatically tested to 22 psig before installation in the GTS system. No alterations to the stamped vessel are allowed by JLab staff, it must be a code shop. Operators of pressure system devices should have SAF 130A training.

## Primary Hazard (C2) - Risk Code 4

Damage or injury due to failure to install or remove the tank covers or flanges properly.

## Primary Hazard (C2) Mitigation - Risk Code 1

Workers must carefully follow the administrative procedures for bolting, filling, pumping, purging, emptying, and unbolting the HVPS tank, transmission line, and gun tank. Only in the Test & Maintenance mode, when the tank is not pressurized, will the flanges ever be closed with **less than** the full complement of bolts. When all bolts are fully engaged, the tank is designed to be capable of withstanding at least 73,964 lbs. of force at 22 psig.

If any bolts in the pressure tank system are loosened or removed, an appropriate log entry must be made in the GTS system log (FGTSLOG).

Procedure B is to ascertain that all bolts holding the pressure tank door closed have been installed and tightened properly. After installation, a second person is to check and ensure all bolts are tight. An entry is then made in the GTS system log prior to the tanks being pressurized.

## D HAZARDS ASSOCIATED WITH SULFUR HEXAFLUORIDE (SF<sub>6</sub>) GAS:

Sulfur hexafluoride (SF<sub>6</sub>) is used as the insulating gas for the GTS Gun HVPS. It is a heavier than air and can create a localized ODH area, especially in pits or enclosed rooms. Refer to the MSDS for SF<sub>6</sub> for details.

In this analysis we followed standard practices for quantities of gas that are equal to or less than a K-



size cylinder (2200 ft<sup>3</sup>), a standard industrial size portable gas cylinder. Based on 10 years of operating experience with a similar system, we assume there will be no arcs inside the SF<sub>6</sub> tank to cause decomposition of the gas.

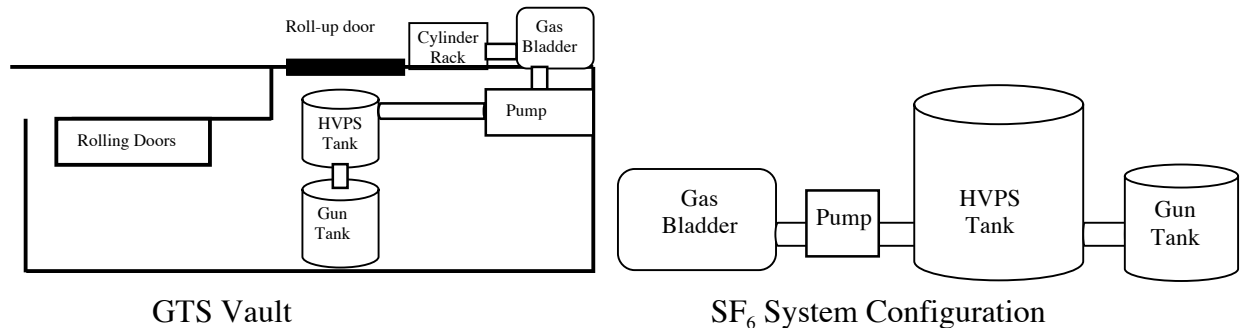

The SF<sub>6</sub> is contained in the above configuration. The following is a detailed description of the arrangement for storing and utilizing the SF<sub>6</sub> including capacities. The system has an outside storage bladder that can hold up to 335 ft<sup>3</sup> of SF<sub>6</sub>. The total SF<sub>6</sub> system volume in the HVPS and Gun tanks in the GTS vault is 154 ft<sup>3</sup>, but the gas is pressurized up to a maximum of 13 psig (relief valve opens to return SF<sub>6</sub> back to storage bag). If the 154 ft<sup>3</sup> of SF<sub>6</sub> were released into the room, it would expand to 290 ft<sup>3</sup>. Since all of the SF<sub>6</sub> must fit into the bladder when the tanks are empty, the maximum volume of SF<sub>6</sub> in the entire system at any time is therefore 335 ft<sup>3</sup>. Once the SF<sub>6</sub> is in the storage bag, it can't flow back up into the vault due to its heavy density and being the lowest point.

The GTS vault, room 109A, has a floor area of 600 ft<sup>2</sup> with a 10-foot ceiling. At one end of the room is an intake duct to the air-handling unit that supplies heated or cooled air mixed with fresh air to the FEL accelerator vault. At the other end of the room is a large rectangular hole in the wall that is open to the back stairwell and hallway (Room 111) that leads to the main FEL accelerator vault, and is covered with steel screen. This hole extends down to within 5.5" of the floor of room 109A. Rooms 109A and 111 are considered air passageways. The air handling system circulates air through this system at 2000 ft<sup>3</sup>/min.

There is one roll up door, normally closed, and a concrete door, normally open when personnel are working in room 109A. The concrete doorway has a metal panel that is normally closed to eliminate airflow, dust, and any possible laser light that might come through the doorway. The doorway opens to room 109B, with a similar area to 109A, namely 600 ft<sup>2</sup>, but a higher ceiling.

## Primary Hazard (D1) - Risk Code 1

Here we assume a release of SF<sub>6</sub> into room 109A with the air conditioning system off. With a room volume of 6000 ft<sup>3</sup>, an SF<sub>6</sub> volume of 335 ft<sup>3</sup> with full dispersion and without air exchange, the dilution would be 1 part of SF<sub>6</sub> in 17 of air. This would not bring the oxygen levels in the room below 18%, (0.944 × 21 = 19.8%) but the level would exceed the Threshold Limited Value (TLV) for SF<sub>6</sub>, which is 1 part of SF<sub>6</sub> in 1000 of air. However, because the SF<sub>6</sub> is considered to be a dense gas with a specific density of 5.1, it will concentrate on the floor of room 109A. The full discharge of SF<sub>6</sub> would cover the floor of room 109A to a depth of 6.7", but at a level 5.5" the gas would start flowing through the large

air vent hole in the wall and out of the room.

Personal injury or death may happen from exposure to SF<sub>6</sub> caused by a sudden gas release inside the GTS vault for personnel with their faces 5.5" or closer to the floor with the air handling system off.

### Primary Hazard (D1) Mitigation - Risk Code 0

In the event of a release of SF<sub>6</sub> into the GTS vault, rooms 109A, 109B, and 111 must be evacuated and notify the Crew Chief and ESH&Q Reporting Officer. In the event the SF<sub>6</sub> disperses sufficiently to reduce the oxygen content at floor levels, an ODH head will alarm. An ODH is placed directly under the HVPS tank and about 3" above the floor. The Safety System Group electronics continuously monitor the ODH sensor.

To evaluate the ODH hazards we perform a risk assessment. It is assumed that workers will not have their face less than 6" off the floor in picking dropped parts. According to JLAB-TN-07-082, the failure rates of mechanical components that comprise this SF<sub>6</sub> system are 1.61 E-05 /hr. The Bureau of Labor Statistics says the probability rate of a professional worker falling and losing consciousness is 2.6 E-7/hr. The American Heart Association says the probability rate for a heart attack is 7.2 E-6/hr. The combined probability of either occurrence is 7.46 E-6/hr. The probability rate for both a mechanical failure and a worker falling to the floor unconscious with both events occurring simultaneously is 1.2 E-10/hr. Thus with a Fatality Factor of 1, the ODH Fatality rate is also 1.2 E-10/hr. Using the ESH&Q manual 6500-T3 will give ODH class 0.

### Secondary Hazard (D2) - Risk Code 3

Corona or arcing in the HVPS may cause toxic breakdown products to form. Electric arcs in SF<sub>6</sub> and oxygen can form toxic byproducts in gaseous or powder form. Examples are SO<sub>2</sub>, HF, H<sub>2</sub>S, SF<sub>4</sub>, S<sub>2</sub>F<sub>10</sub>, and others. These byproducts can be present as impurities in the virgin gas as well as in gas that has been subjected to corona or arcing.

### Secondary Hazard (D2) Mitigation - Risk Code 0

In the event of corona or arcing in the HVPS, the Jefferson Lab Industrial Hygiene group must be notified. The arcing may cause decomposition by-products that are hazardous and should not be inhaled. The contaminated gas can be either processed through a cleaning machine or if needed vented to the atmosphere.

### Secondary Hazard (D3) - Risk Code 4

Injury, death, or damage may happen due to mishandling of gas cylinders. Mechanical damage to a high-pressure gas cylinder may cause a "run-away cylinder" or a cylinder explosion due to excessive heat.

Frostbite to the eyes or exposed skin from venting high-pressure gas may occur due to an improper mechanical connection to a gas cylinder when placing it into service.

### Secondary Hazard (D3) Mitigation - Risk Code 1

Safety glasses and leather gloves shall be used when connecting or disconnecting the SF<sub>6</sub> gas cylinders to the gas system. When opening on the valve, “crack” it open slowly to see and listen for gas escaping at a connection before fully opening the valve.

All high-pressurized gas cylinders shall be secured in a proper bottle storage rack and kept away from sources of heat.

## **E HAZARDOUS AC VOLTAGES:**

### **Primary Hazard (E1) - Risk Code 4**

Injury or death may result from interaction with the electrical supply, 208 VAC, 3 $\phi$ , of the Glassman HVPS. This represents a Class 2, Mode 2 electrical hazard.

### **Primary Hazard (E1) Mitigation - Risk Code 1**

Using the engineering and administrative controls as provided in JLab EH&S Manual Chapter 6200 and the Glassman HVPS operating manual mitigate this hazard. The 2-man rule applies.

The input power, 208 VAC, is supplied through a lockable disconnect switch, a voltage verification unit (VVU), and a 5-wire cable via conduit to the power supply. Barrier strips cover the power supply terminals. The VVU is connected to the load side of the disconnect switch to enable safe and quick verification of whether or not the 208 VAC power is going to the HVPS.

### **Primary Hazard (E2) - Risk Code 3**

Physical injury may occur from involuntary reaction to electrical shock.

### **Primary Hazard (E2) Mitigation - Risk Code 1**

See Hazard Mitigation (E1).

The Glassman power supply operates from 208 VAC 3 $\phi$  power, and produces about 12 kV chopped square wave voltage for multiplication. The most serious electrical hazards in this entire system are the rectified 208 volts used in the PWM choppers and the chopped high voltage drive power.

This is a Class 2, Mode 2 Hazard. Refer to the Glassman manual when working on these circuits. The 2-man rule applies until the system is safe under Lock, Tag, & Try.

## **F MATERIAL HANDLING:**

### **Primary Hazard (F1) - Risk Code 4**

Injury or death from trauma associated with lifting and moving heavy objects.

### **Primary Hazard (F1) Mitigation - Risk Code 1**

Using the engineering and administrative controls as provided in JLab EH&S Manual Chapter 6140 on Cranes and Hoists and Chapter 6145 on Forklifts mitigate this hazard. As associated with moving heavy objects, the main blanking plates and the transmission line components are heavy and require special rigging when moving and installing. While the HVPS pressure tank door is heavy, it rolls on a castor and is easily moved by one person. Care must be exercised to prevent smashed fingers when closing the door.

## 6 List Of Safety Equipment

### Personal Protective Equipment

Personal Protective Equipment (PPE) is required when making the system safe. PPE includes:

1. Non-melting/untreated natural fiber long pants and long sleeved shirt or jacket
2. Safety glasses.
3. Leather gloves when installing and/or removing the HVPS door bolts

### Special Tools

Ground Sticks are provided to ensure the internal capacitors have been discharged and that no high voltage is inside the Gun or the HVPS.

Lock-Tag & Try personal lock(s), labels and a hasp to be used in the HVPS disconnect.

## DEVELOP THE PROCEDURE

### 1. Associated Administrative Controls

For normal operations:

- Thorough understanding of this document
- Training listed in section 4.4 above
- Approval from GTS system owner, Carlos Hernandez-Garcia

For maintenance and repairs:

- Training and approval of task by Tom Powers
- FEList entry describing the task to be performed
- Notification of affected personnel listed in section 3 below.
- Thorough understanding of this document
- Training listed in section 4.4 above

### 2. Operating Guidelines

Before starting repair and/or maintenance work on the GTS 600kV HVPS, ensure to follow the administrative controls described in section 1 above. Once the approvals for repairs and/or maintenance work:

1. Proceed with ensuring that the GTS 600kV HVPS disconnect is Off
2. Apply personal lock to the HVPS disconnect following Lock, Tag & Try guidelines
3. Verify power is OFF with the VVU and the EPICS screen for the GTS 600kV HVPS.

The HVPS disconnect is located on the south wall of the GTS mezzanine located in FEL building 18 Room 217.

### 3. Notification of Affected Personnel (who, how, and when)

Prior to the implementation of this OSP, for any repairs, maintenance and/or configuration changes of the GTS 600kV HVPS, notify in person or by phone all of the following persons:

FEL Division Safety Officer, Steve Benson, 269-5029

GTS system owner: Carlos Hernandez-Garcia, 269-6862

GTS 600kV HVPS system owner: Tom Powers, 269-7660.

### 4. List the Steps Required to Execute the Procedure: from start to finish.

#### Background:

A Voltage Verification Unit (VVU) is mounted on the south wall of room 217 near the rack housing the Glassman HVPS Remote Control Unit. The VVU is wired just downstream of the power supply 208 VAC disconnect Switch. The VVU is used to verify that indeed the 208 VAC has been disconnected from the power supply.

The 600 kV Power Supply is a JLab modified Glassman model PS/PK500N004YU2 consisting of a voltage multiplier stack, a monitor stack, and a power driver. The multiplier stack is a 48 stage full-wave Cockcroft-Walton (C-W) voltage multiplier, rated in air at 500 kV and 4 mA. The C-W stack was modified with smaller corona rings and installed in a pressure tank. When this tank is filled with sulfur hexafluoride ( $SF_6$ ) gas above 5 psig, additional insulation and cooling is provided for operation up to 600 kV and 5 mA. The power driver electronics have also been modified to achieve this output.

The monitor stack acts as the voltage feedback divider for the power driver circuitry, provides a divider probe for both the AC and DC components of the output voltage, and acts as bleeder resistors for the capacitors of the multiplier stack. The AC and DC outputs can be viewed on an oscilloscope to verify proper operation.

The solid-state pulse width modulated (PWM) power drive unit provides up to 12 kV of drive voltage for the C-W multiplier stack. The power input to the driver is 208 VAC 3-phase, which is directly rectified and filtered for use in the PWM chopper.

Refer to the Glassman service manual for a more complete description of this unit.

The insulating Gas Handling system consists of mechanical pumps and various solenoid control valves used to fill the HVPS & Gun tanks with  $SF_6$ . Instrument air is used to purge and backfill the tanks prior to opening either tank. The mechanical pumps with switching valves are used to evacuate the  $SF_6$  from the tanks to the gas storage bag and to evacuate the tanks of air prior to backfilling with  $SF_6$ . For any  $SF_6$  that is lost from the system, several high-pressure  $SF_6$  gas cylinders, located outside, are used to refill the gas recovery bag. If the pressure in the tanks is above 13 psi, a relief valve opens and the  $SF_6$  flows back into the recovery gas bladder. The system is designed to be pressurized up to 10 psig and is equipped with the normal complement of control valves and pressure gauges. Refer to JLab drawing 05001-E-0001, FEL GTS Inst. Air, N<sub>2</sub>, and  $SF_6$  Flow Schematic FEL Building for the details of the GTS Gas Handling system.

The connection between the HVPS and the electron gun is a gas insulated 18 inch OD tube (referred to as nipple from now on) bolted to the bottom of the HVPS  $SF_6$  tank, and oriented 90 degrees with respect to the axis of the tank. The transmission line consists of a 320 Mega-Ohm resistor between the high voltage

end of the HVPS. And the electron gun This resistor is coaxial to the nipple and can be connected to the electron gun via two mechanisms, depending on the gun configuration:

- Cylindrical insulator (FEL style): The conditioning resistor is connected to an extension tube, 5 inches in diameter, which in turn connects to the high voltage end of the HVPS. The conditioning resistor is then placed between the extension tube and the high voltage end of the electron gun. The electron gun is enclosed in an Aluminum tank that bolts directly to the nipple, effectively sharing the SF<sub>6</sub> environment with the HVPS tank. The nipple then serves as a ‘bridge’ between the HVPS and the FEL style electron gun. In this configuration, all of the HVSP and gun electrical components are enclosed in tanks pressurized to 10 psi with SF<sub>6</sub>.

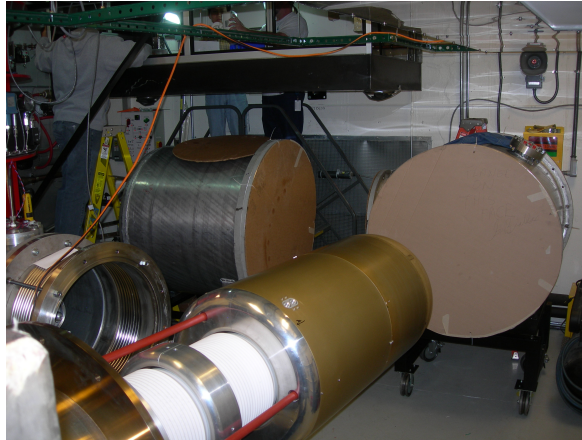

- Inverted conical insulator (CEBAF style): The conditioning resistor is connected to an epoxy (R30 or R28, depending on the experiment) receptacle. The receptacle is bolted to a 20 inch OD blank flange, which in turn is bolted down to the nipple. The receptacle therefore provides electrical connection between the resistor and a cable, and provides mechanical support to the resistor. The other end of the cable is connected to the CEBAF-style electron gun that has either a R28 or R30 insulator holding the electrode inside the vacuum chamber.

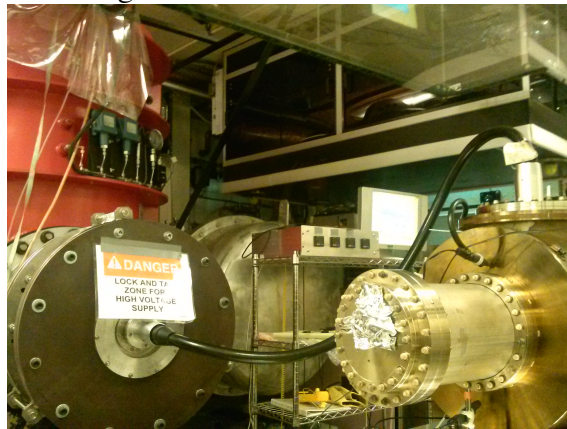

## A Lockout, Tag, & Try Procedure for the Gun HVPS:

If work is to be performed inside the HVPS tank, photocathode Gun tank, or the PWM power drive unit, the system must be made safe under Lock, Tag, & Try using the VVU and the wall mounted disconnect switch located above the GTS vault, on the south wall next to the GTS control room, labeled “GTS GUN HVPS”. A provided ground hook is to remain attached to a grounding point as long as the tank is open. For work on the power drive unit, see additional cautions in the Glassman instruction manual.

1. Prior to performing any work on the Gun or Gun HVPS, check the Gun HVPS Voltage Verification Unit (VVU) for proper operation. The green LED's are On, the Line to Line readings are 208 VAC, and the Line to Neutral readings are 120 VAC.
2. Turn off the GTS Gun HVPS disconnect switch, lock it off with a hasp, your personal lock, and your tag. Place the key in your pocket.
3. Check the VVU again. The green LED's are Off, the Line-to-Line readings are 0 VAC, and the Line to Neutral readings are also 0 VAC. If this is not correct, contact the system owner (Tom Powers) for direction. Do not proceed until these conditions are established.
4. If work is to be performed inside the HVPS tank, evacuate the SF<sub>6</sub> per procedure **D** below. Then return to step 5 below. If no work will be performed inside the HVPS tank, skip to step 7.
5. Rope off the hazardous test area with a 4 ft. Restricted Approach Boundary, per Table 130.2(C) of NFPA 70E. Post Danger High Voltage signs to ensure that access is restricted and safe for any work and tests.

---

**WARNING:** Be sure to perform a visual inspection of the grounding hook, cable and rod. Ensure the grounding hook is securely attached to the rod, the cable is not frayed and the cable is securely attached to the hook and the ground point. Using a defective grounding hook and/or misuse of the grounding hook could result in personal injury!

---

6. Unbolt the HVPS tank and swing the door open about 1 foot. While wearing safety glasses and with an additional electrical worker (2 man rule applies), install the ground hook on a lower post supporting one of the two stacks inside the tank. Face completely away from the grounding point just prior to touching it with the grounding hook. The door can now be opened as much as needed to perform the required work. Note in the FGTSLOG the tank was opened.
7. The GTS Gun HVPS is now in a safe mode.

## **B Pressurization Pre-check with Instrument Air after Repairs to the Gas System:**

1. Check that all HVPS door bolts are properly installed and torqued to 100 ft-lbs.
2. Check that tank pressure is 0 psig as indicated on pressure gauge located on the side of the HVPS tank.
3. Ensure all valves are closed. On the following page, see Figure 1, SF<sub>6</sub> Control Panel.
4. Open valve 9 by moving switch SW 6 to the right. Moving any switch to the right causes it to close and become operating. Moving a switch to the left cause it to open and be inactive.
5. When the tank pressure gauge reads 10 psig, close valve 9 by opening SW 6. Listen for gross leaks around the tanks.
6. If there are gross leaks, mark them and go to step 7, otherwise go to step 8.
7. Pump the tank to the atmosphere by operating SW 1. This will open valves 1, 7, 8, and turn on the vacuum pump. After the pressure gauge reaches 0 psig, turn SW 1 off and make the necessary repairs. Go to B-1 to repeat this entire test.
8. At this point, there should be no gross leaks. Check the welds and joints with "snoop" or a soap solution. If there are any leaks, mark them and go to step 7, otherwise go to step 9.
9. Record the pressure reading and the time for future reference.
10. After 4 hours, record the pressure reading and time. If the pressure has dropped by 0.1 psig, find the leak, mark it, and go to step 7, otherwise go to step 11.
11. The tank is leak tight. Pump the tank to the atmosphere by operating SW 1. When the pressure gauge reaches 0 psig, turn SW 1 off.

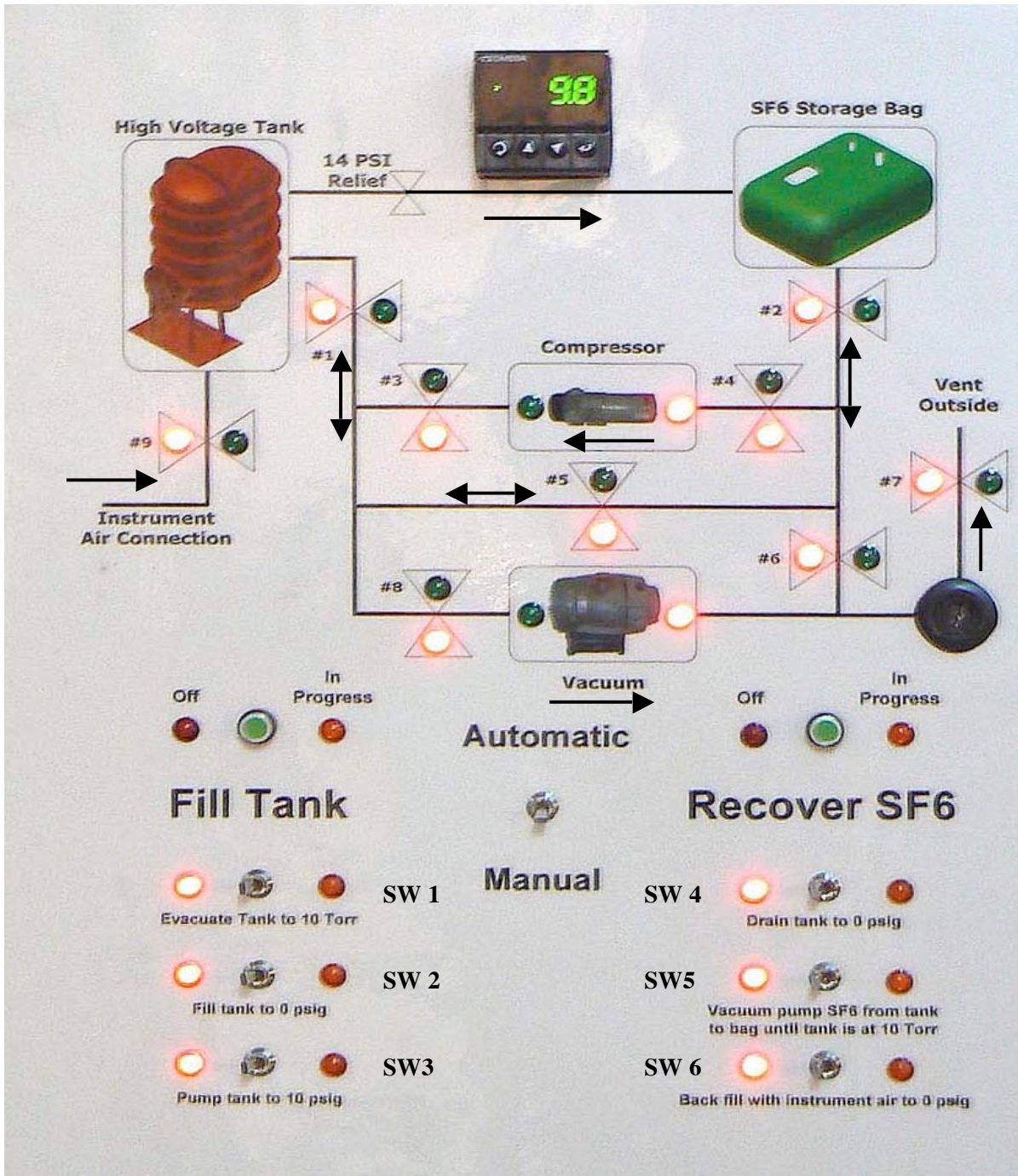

Figure 1 SF<sub>6</sub> Control Panel

### C Filling the Gas System with SF<sub>6</sub> Insulating Gas:

1. Check the log to determine if the tank has been opened, any bolts removed or loosened, and the gas pressure just prior to its pump out.



2. Ensure that all bolts are in place and properly tightened.
3. Ensure all valves are closed.
4. Evacuate the tanks to the outside vent by operating SW 1. This will open valves 1, 7, 8, and turn on the vacuum pump. If the pump's vent line becomes hot to the touch, open SW 1 and allow it to cool down. After the vent line has cooled, operate SW 1 again to restart the vacuum pump and continue evacuating the tanks.
5. When the tank pressure gauge reaches -26 in. of Hg, open SW 1 to close the opened valves and turn off the vacuum pump.
6. If the bladder is over 2/3 inflated with SF<sub>6</sub>, then additional SF<sub>6</sub> is not needed. Proceed to step 11, otherwise go to step 7.
7. More SF<sub>6</sub> gas must be added to the bag in order to bring the tank to a final operating pressure of 10 psig. Open the valve on the SF<sub>6</sub> bottle and set the SF<sub>6</sub> regulator to 25 psig.
8. Open the ball valve just downstream of the regulator.
9. Inflate the bladder to slightly more than 2/3 full.
10. When the bladder reaches 2/3 full, close the ball valve and the valve on the SF<sub>6</sub> bottle.
11. Ensure all valves shown on the SF<sub>6</sub> Control Panel are closed. Start backfilling the tank by operating SW 2 to open valves 1, 2, and 5. The differential pressure between the SF<sub>6</sub> bladder and the tank will push the SF<sub>6</sub> into the tank.
12. When tank pressure gauge reads above 5 in. of Hg, open SW 2 and operate SW 3. This will close valve 5, open valves 3, 4, and start the compressor pump.
13. When the pressure gauge reads 10 psig, open SW 3. All valves are now closed and the pumps are off. The final tank pressure must be between 5 and 10 psig. If the bladder is empty (flat) and the tank pressure is less than 10 psig, go back and repeat steps 7 through 10 to add more SF<sub>6</sub> to the bladder and enable the final pressure to be brought to 10 psig.

**Notice:** Under no circumstances ever exceed **12 psig** system operating pressure as the pressure relief valve will start opening at this pressure. Assume the pressure will increase 1 psig due to the power supply heating the insulating gas.

14. Ensure all valves are closed and AC power is off to the pumps. The HVPS tank is now ready for operation.

## D Evacuating the Gas System of SF<sub>6</sub> Insulating Gas:

When access is required into either the HVPS tank or the Gun tank, the SF<sub>6</sub> insulating gas must be moved from the tanks to the SF<sub>6</sub> storage bladder before any bolts on the tanks are removed. This is accomplished by:

1. Check the Voltage Verification Unit (VVO) for proper operation and readings for 208 VAC. Switch off the HVPS 208 ACV disconnect switch located on the South wall of the GTS Control Room. It is labeled "GTS GUN HVPS". Test with the VVO that no voltage is present on the AC lines. Note that everyone intending to working on either the HVPS or Gun tanks must now place their locks and tags on the disconnect switch. Go to Procedure A, Lockout, Tag, & Try for the Gun HVPS.
2. Ensure all valves are closed.
3. Operate SW 4 to open valves 1, 2, and 5. The differential pressure between the SF<sub>6</sub> storage bladder and the tank will push the SF<sub>6</sub> into the bladder.
4. When the tank pressure gauge reads about 5 psig, open SW 4 and operate SW 5. This will close valve 5, open valves 6 and 8, and turn on the vacuum pump. If the pump's vent line becomes hot to the touch,

close SW 5 and allow it to cool down. After the vent line has cooled, operate SW 5 again to restart the vacuum pump and continue evacuating the tanks.

5. When the tank pressure gauge reads about -26 in of Hg, open SW 5. This turns off the vacuum pump, closes valves 1, 2, 6, and 8.
6. Ensure the instrument air regulator is set to 22 psi and the ball valve downstream of the regulator is open.
7. Operate SW 6. This opens valve 9 and allows instrument air into the tank.
8. Closely monitor the tank pressure gauge.
9. When the tank pressure gauges read 0.25 psig, open SW 9 to close valve 9 and stop the flow of instrument air into the tanks. Ensure all valves are closed and pumps are off.
10. Remove the bolts on the tank door that needs to be opened and open the tank door.

**5. Back Out Procedure(s)** i.e. steps necessary to restore the equipment/area to a safe level.

Not Applicable. These procedures are to make the HVPS safe.

**6. Special environmental control requirements:**

**6.1 Environmental impacts** (See [EMP-04 Project/Activity/Experiment Environmental Review](#))

## Environmental Management Information (EMP-04)

### Air, Water, and Waste Information

Anticipated Air Emissions: Non expected unless in case of emergency: 335 cubic feet of sulfur hexafluoride in the event of contamination of the gas.

Water-Based Project?   No  

Source of Water for the Project   NA  

How is water to be discharged or disposed (provide estimated quantity):   NA  

Sanitary Sewer   NA  

Surface Water   NA  

Other types of Waste Generated   NA  

Waste Disposal Plan (attach additional information as necessary)   None anticipated.  

Special Sanitary Sewer Discharge   NA  

Other Waste Water   NA  

Hazardous Waste   NA  

Solid Waste (landfill or recycling)   NA  

Name/Description of Waste Generated/Anticipated Quantity:   NA  

Power/Natural Resource Consumption Expected   4 kW  

**6.2 Abatement steps** (secondary containment or special packaging requirements)

None are needed.

**7. Unusual/Emergency Procedures** (e.g., loss of power, spills, fire, etc.)

## Emergency Procedures

### 1. Exposure to Liquid or Cold Sulfur Hexafluoride

**Eye** Flush eyes with plenty of lukewarm water for several minutes.  
Call the Crew Chief at 7050 for help.  
See Emergency/Medical Services.

**Inhale** Immediately leave room and seek fresh air.  
Call Crew Chief at 7050 for help.  
If person is not breathing, call 911 and administer artificial respiration.  
If breathing is difficult, seek Emergency/Medical Services.

**Skin** Remove contaminated clothing and flush with lukewarm water for several minutes.  
Call Crew chief at 7050 for help.  
Seek Emergency/Medical Services for frostbite.

### 2. ODH Alarm in GTS Vault

Leave the building and call the Crew Chief at 7050 to investigate the problem.  
After permission is given to re-enter the building, ensure the building air handling system is functioning to dissipate any residual gas.

## 8. Instrument Calibration Requirements (e.g., safety system/device recertification, RF probe calibration)

### Verifying the Machine Protection System for the HVPS

After maintenance work on the HVPS tank, a machine down for HVPS repairs, or annually, the Machine Protection System shall be verified for proper operation prior to start up of Operations.

1. The Pressure Relief valve is tested by increasing the SF<sub>6</sub> pressure and verifying the Relief valves opens at about 12.5 psi. Check the SF<sub>6</sub> storage bag outside to ensure there is sufficient gas in it for the test. Never exceed 15 psi under any circumstances. Verify the Pressure Relief valve is closed above 10 psi by monitoring the tank pressure gauge for 10 minutes.
2. The tank Door Closed switch is tested by removing the switch's cover/striker plate and verifying the interlock permission is lost on the EPICS GTS 600kV Power Supply screen. Re-install the cover/striker plate after the test.
3. The tank Pressure Switch is tested by lowering the SF<sub>6</sub> pressure in the HVPS tank until the interlock permission is lost. This must happen at 5 psi or slightly higher.
4. Make a GTS Log entry stating the HVPS interlocks were successfully tested and verified.

## 9. Inspection Schedules

During Annual downs.

## 10. References/Associated Documentation

Glassman High Voltage, Inc. Instruction Manual, PK Series. The Instruction Manual includes installation & operating instructions, schematics, cable lists, wiring diagrams with signal names, and basic assemble drawings. Tom Powers has ownership of the Instruction Manual.

## 11. List of Records Generated (Include Location / Review and Approved procedure)

**Click  
 To Submit OSP  
 for Electronic Review**

**Distribution:** Copies to: affected area, authors, Division Safety Officer

**Expiration:** Forward to ESH&Q Document Control

### Form Revision Summary

**Revision 1.2 – 09/15/12** – Update form to conform to electronic review.

**Revision 1.1 – 04/03/12** – Risk Code 0 switched to N to be consistent with [3210 T3 Risk Code Assignment](#).

**Revision 1 – 12/01/11** - Added reasoning for OSP to aid in appropriate review determination.

**Revision 0 - 10/05/09** – Updated to reflect current laboratory operations

ISSUING AUTHORITY	FORM TECHNICAL POINT-OF-CONTACT	APPROVAL DATE	REVIEW REQUIRED DATE	REV.
ESH&Q Division	<a href="#">Harry Fanning</a>	12/01/11	12/01/14	1.2

*This document is controlled as an on line file. It may be printed but the print copy is not a controlled document. It is the user's responsibility to ensure that the document is the same revision as the current on line file. This copy was printed on 12/17/2013.*

## Task Hazard Analysis (THA) Worksheet

(See [ES&H Manual Chapter 3210 Appendix T1](#)  
Work Planning, Control, and Authorization Procedure)



<b>Author:</b>	Carlos Hernandez-Garcia	<b>Date:</b>	December 9, 2013	<b>Task #:</b> <small>If applicable</small>	
<b>Complete all information. Use as many sheets as necessary</b>					
<b>Task Title:</b>	<b>GTS 600 kV Gas Insulated Power Supply Maintenance &amp; Safety</b>	<b>Task Location:</b>	Gun Test Stand, Building 18, Room 109A (AKA GTS vault)		
<b>Division:</b>	FEL	<b>Department:</b>		<b>Frequency of use:</b>	As needed for either repairs to the HVPS (unlikely) or normal operations for connecting HVPS to electron gun.
<b>Lead Worker:</b>	Carlos Hernandez-Garcia, and/or Tom Powers				
<b>Mitigation already in place:</b>	<a href="#">Standard Protecting Measures</a> <a href="#">Work Control Documents</a>				

Sequence of Task Steps	Task Steps/Potential Hazards	<u>Consequence Level</u>	<u>Probability Level</u>	<u>Risk Code</u> <small>(before mitigation)</small>	Proposed Mitigation <small>(Required for <u>Risk Code</u> &gt;2)</small>	Safety Procedures/ Practices/Controls/Training	<u>Risk Code</u> <small>(after mitigation)</small>
	Repairs to the Glassman Remote control unit, to the input drive, and/or the voltage multiplier stack. Potential Hazard: Injury or death may result from interaction with the electrical supply, 208 VAC, 3φ, of the Glassman HVPS.	H	M	4	Using the engineering and administrative controls as provided in JLab EH&S Manual Chapter 6200 and the Glassman HVPS operating manual mitigate this hazard. The 2-man rule applies.	Prior to any electrical work, ensure that the HVPS disconnect is turned OFF and that lock out, tag out procedures are followed. The input power, 208 VAC, is supplied through a lockable disconnect switch, a voltage verification unit (VVU), and a 5-wire cable via conduit to the power supply. Barrier strips cover the power supply terminals. The VVU is connected to the load side of the disconnect switch to enable safe and quick verification of whether or not the 208 VAC power is going to the HVPS.	1

# Task Hazard Analysis (THA) Worksheet

(See [ES&H Manual Chapter 3210 Appendix T1](#)  
[Work Planning, Control, and Authorization Procedure](#))

Sequence of Task Steps	Task Steps/Potential Hazards	Consequence Level	Probability Level	Risk Code (before mitigation)	Proposed Mitigation (Required for Risk Code >2)	Safety Procedures/ Practices/Controls/Training	Risk Code (after mitigation)
	<p>Connecting the electron gun to the HVPS. Injury or death may result from interaction with high DC voltages.</p> <p>The 600 kV produced by the power supply system is a serious hazard, even with the power supply maximum output current limited to 5 mA. This is a Class 3, Mode 2 Hazard.</p>	H	M	4	<p>The HVPS and Gun tanks shall not be opened for at least 1 minute after the HVPS has been turned off. The time needed to open either of the HVPS or Gun tanks is about 45 minutes. The power supply is only operated inside the pressure tank and has many large bolts that must be removed to gain access to the power supply inside. This engineering constraint of the system is adequate to ensure workers cannot come in contact with the stored electrical energy before it's had an opportunity to bleed off.</p>	<p>Interlocks are provided to ensure the pressure tank door is closed during normal operation of the power supply. A pressure-sensing switch is also installed to ensure the tank is pressurized before the high voltage is energized. These interlocks are independent from the PSS system and are tied directly to the HVPS interlock system.</p> <p>Prior to performing work within the high voltage tank, transmission line, or photocathode gun, workers wearing safety glasses shall attach the appropriate grounding hook to discharge any remaining energy stored in the HVPS or Gun. Whenever practicable, the grounding hook or probe shall remain in place during Test and Maintenance mode to prevent accumulation of energy.</p> <p>The 12 kV square-wave fed to the multipliers is enclosed in 40 kV insulated wires, with additional vinyl tubing over each of these wires. This connection is only a few feet long and has a protective barrier.</p>	1

# Task Hazard Analysis (THA) Worksheet

(See [ES&H Manual Chapter 3210 Appendix T1](#)  
[Work Planning, Control, and Authorization Procedure](#))

Sequence of Task Steps	Task Steps/Potential Hazards	Consequence Level	Probability Level	Risk Code (before mitigation)	Proposed Mitigation (Required for Risk Code >2)	Safety Procedures/ Practices/Controls/Training	Risk Code (after mitigation)
	<p>Opening the HVPS tank for connecting resistor between HVPS and electron gun. Injury may result from flying debris if the HVPS tank, transmission line, or supply system should experience a failure that leads to a rupture of one of these pressure tanks. Injury is also possible from the bolts securing the tank cover and flanges, if the bolts are improperly installed or some of the bolts are left out, causing the bolts to fracture.</p>	H	M	4	<p>The HVPS tank, transmission line, and photocathode gun system are not considered to be a pressurized vessel per ASME Boiler &amp; Pressure Vessel Code - Sec. VIII, since it will not be pressurized over 15 psig. The HVPS tank and piping system includes a 13 psig pressure relief valve to prevent system overpressure, two externally mounted pressure gauges, and system control valves. The relief valve was made and tested by an ASME qualified company to be fully open at 14 psig.</p> <p>The HVPS tank was designed, built, tested, and stamped by the manufacturer as if it were going to be a pressure vessel. The tank and its components have been hydrostatically tested to 22 psig before installation in the GTS system. Any modifications to the tank or other pressurized components will require a review to verify the integrity of the system.</p>	<p>Workers must carefully follow the administrative procedures for bolting, filling, pumping, purging, emptying, and unbolting the HVPS tank, transmission line, and gun tank. Only in the Test &amp; Maintenance mode, when the tank is not pressurized, will the flanges ever be closed with <b>less than</b> the full complement of bolts. When all bolts are fully engaged, the tank is designed to be capable of withstanding at least 73,964 lbs. of force at 22 psig.</p> <p>If any bolts in the pressure tank system are loosened or removed, an appropriate log entry must be made in the GTS system log (FGTSLOG).</p> <p>Procedure B is to ascertain that all bolts holding the pressure tank door closed have been installed and tightened properly. After installation, a second person is to check and ensure all bolts are tight. An entry is then made in the GTS system log prior to the tanks being pressurized.</p>	1

For questions or comments regarding this form contact the Technical Point-of-Contact [Harry Fanning](#)

This document is controlled as an on line file. It may be printed but the print copy is not a controlled document. It is the user's responsibility to ensure that the document is the same revision as the current on line file. This copy was printed on 12/6/2012

# Task Hazard Analysis (THA) Worksheet

(See [ES&H Manual Chapter 3210 Appendix T1](#)  
[Work Planning, Control, and Authorization Procedure](#))

Highest [Risk Code](#) before Mitigation:

4

Highest [Risk Code](#) after Mitigation:

1

When completed, if the analysis indicates that the [Risk Code](#) before mitigation for any steps is “medium” or higher (RC≥3), then a formal [Work Control Document](#) (WCD) is developed for the task. Attach this completed Task Hazard Analysis Worksheet. Have the package reviewed and approved prior to beginning work. (See [ES&H Manual Chapter 3310 Operational Safety Procedure Program](#).)

### Form Revision Summary

**Revision 0.1 – 06/19/12** - Triennial Review. Update to format.

**Revision 0.0 – 10/05/09** – Written to document current laboratory operational procedure.

ISSUING AUTHORITY	FORM TECHNICAL POINT-OF-CONTACT	APPROVAL DATE	EXPIRATION DATE	REV.
ESH&Q Division	<a href="#">Harry Fanning</a>	06/19/12	06/19/15	0.1

*This document is controlled as an on line file. It may be printed but the print copy is not a controlled document. It is the user's responsibility to ensure that the document is the same revision as the current on line file. This copy was printed on 12/9/2013.*



