

PRELIMINARY
 03-10-14
 REV 05

- NOTES**
- ASME Y14.5-2009 IS USED FOR ALL DIMENSIONING AND TOLERANCING. ALL DIMENSIONS ARE IN MILLIMETERS.
 - DO NOT USE MAGNETS FOR HANDLING OR MACHINING OPERATIONS.
 - APPROXIMATE WEIGHT OF CORE STEEL IS 27 LB.
 - BEFORE MACHINING: ANY EXISTING HOLES IN JL0008745 ITEM 1 SHALL BE ON THE BOTTOM FACE OF CORE HALF. NO EXISTING HOLES SHALL BE IN THE POLE FACE OR MATING SURFACES.

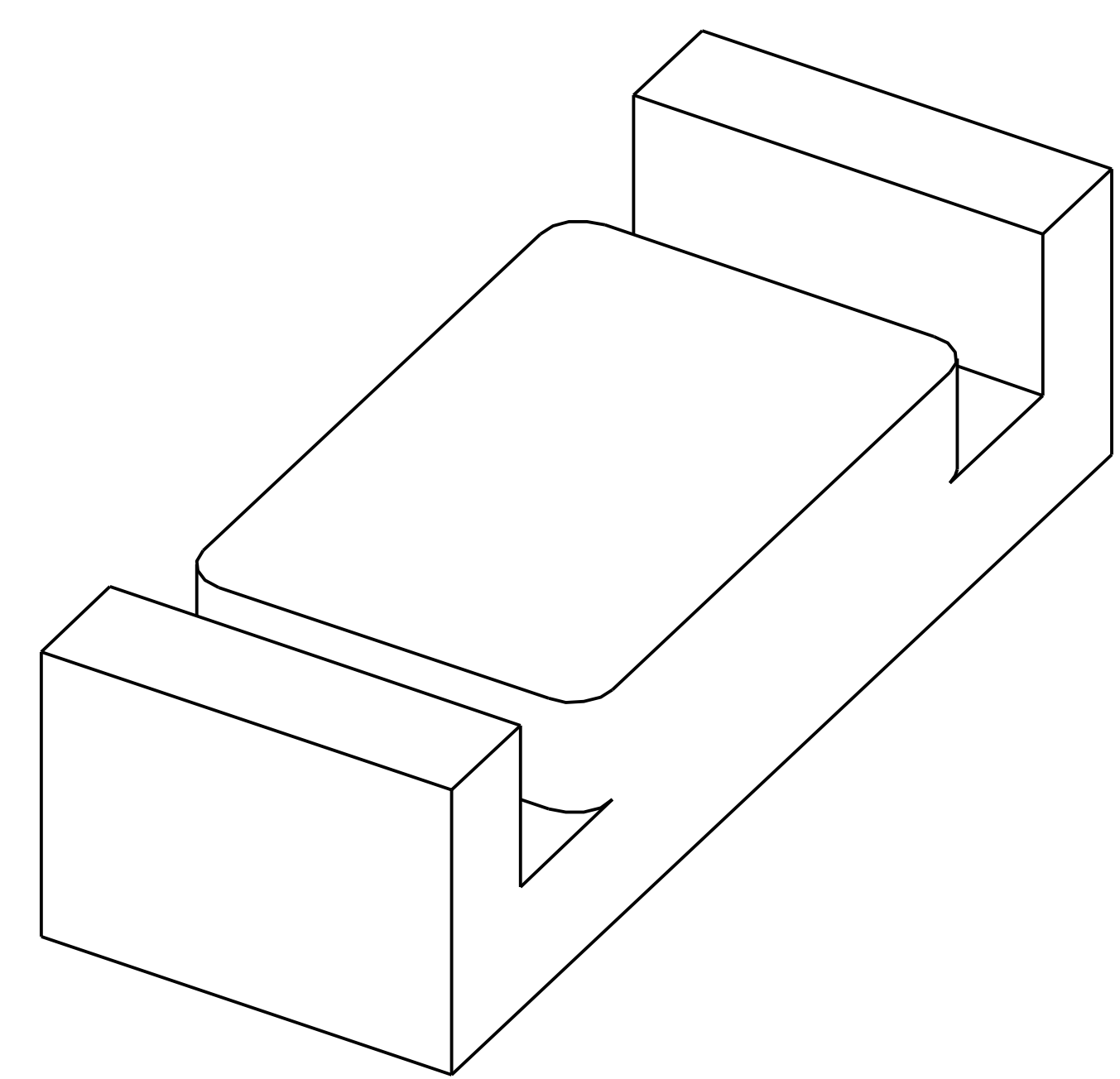

ISOMETRIC
(NOT TO SCALE)

4	1	JL008745 ITEM 1	DL MAGNET CORE HALF	STEEL AISI 1006	4
QTY	ITEM	PART OR IDENTIFYING NO.	NOMENCLATURE OR DESCRIPTION	MATERIAL SPECIFICATION	NOTES
PARTS LIST					
EACH SHEET OF MULTI-SHEET DRAWINGS SHALL ALWAYS HAVE THE SAME REVISION LEVEL.					
UNLESS OTHERWISE SPECIFIED, DIMENSIONS ARE IN MILLIMETERS. TOLERANCES ARE:		TRACKING NO. N/A		United States Department of Energy	
FRACTIONS: DECIMAL ANGLES: ± 50°		APPROVALS		Jefferson Lab Newport News Virginia	
± N/A ± 0.1 ± 0.05		DATE		MAG CORRECTOR DL	
THIRD ANGLE PROJECTION		DRAWN S.A. OREGORY		DL MAGNET CORE HALF	
FINISH MACHINED SURFACES UNLESS OTHERWISE NOTED		CHECKED		SIZE DWG NO. JL0008098	
DO NOT SCALE DRAWING		APPROVED		REV -	
SCALE 1:1		REV IN RSP NO. JL0008742		SHEET 1 OF 1	