

BOM62098 BJ1817C00039_RA_V1 5/12/2014 11:29

BILL OF MATERIALS					
NO.	PART NUMBER	DRAWING NUMBER	DESCRIPTION	QTY	UM
01	D-PRD118573-05S010	PRD118573-05S010	CHAMBER INITIAL DETAIL / WELDMENT FOR BJ1817C00039	1	EA
02	D-PRD118573-05S002	PRD118573-05S002	MODIFIED F1000X000NT FOR BJ1817C00039	1	EA
03	D-PRD118573-05S005	PRD118573-05S005	MODIFIED F0450X200R FOR BJ1817C00039	1	EA
04	SST-02501		TUBING, SS304L 2-1/2" OD, .065" WALL, ASTM A270 POLISHED OD & ID	1.53	IN

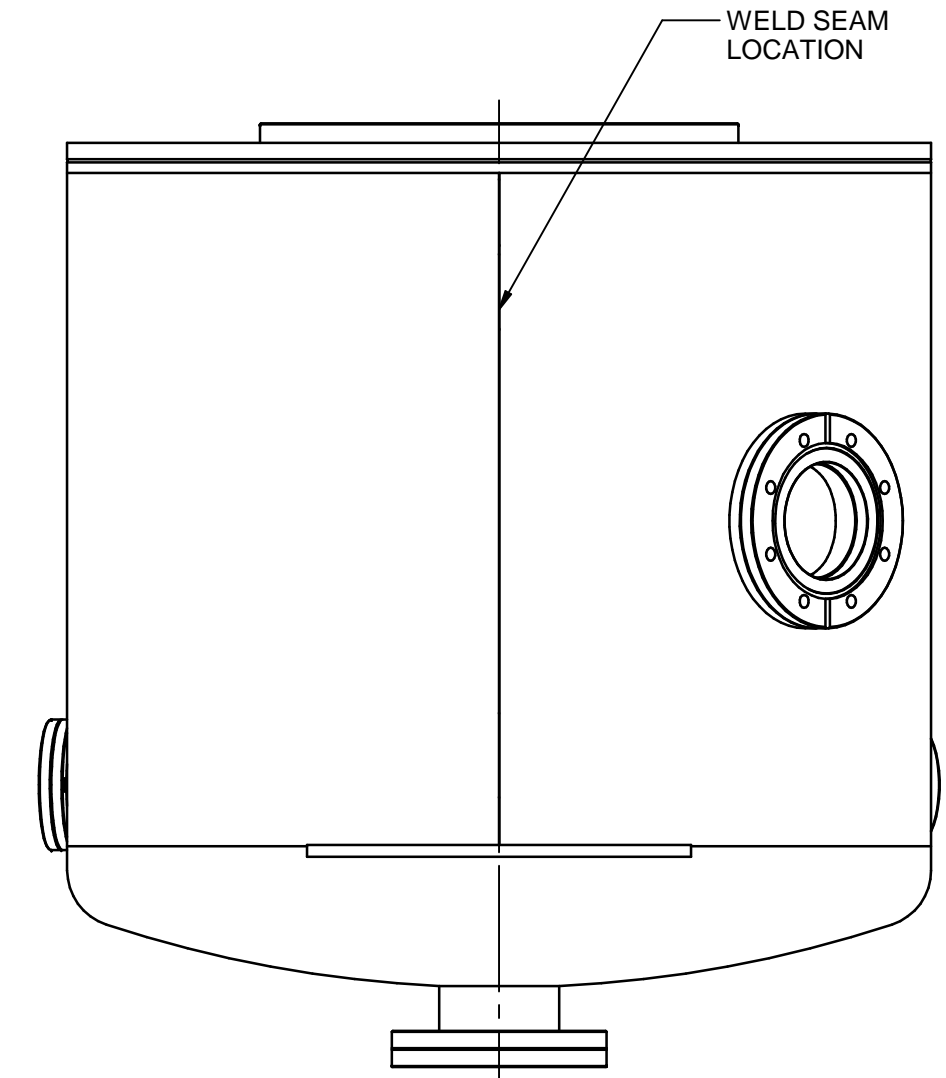

TOP VIEW

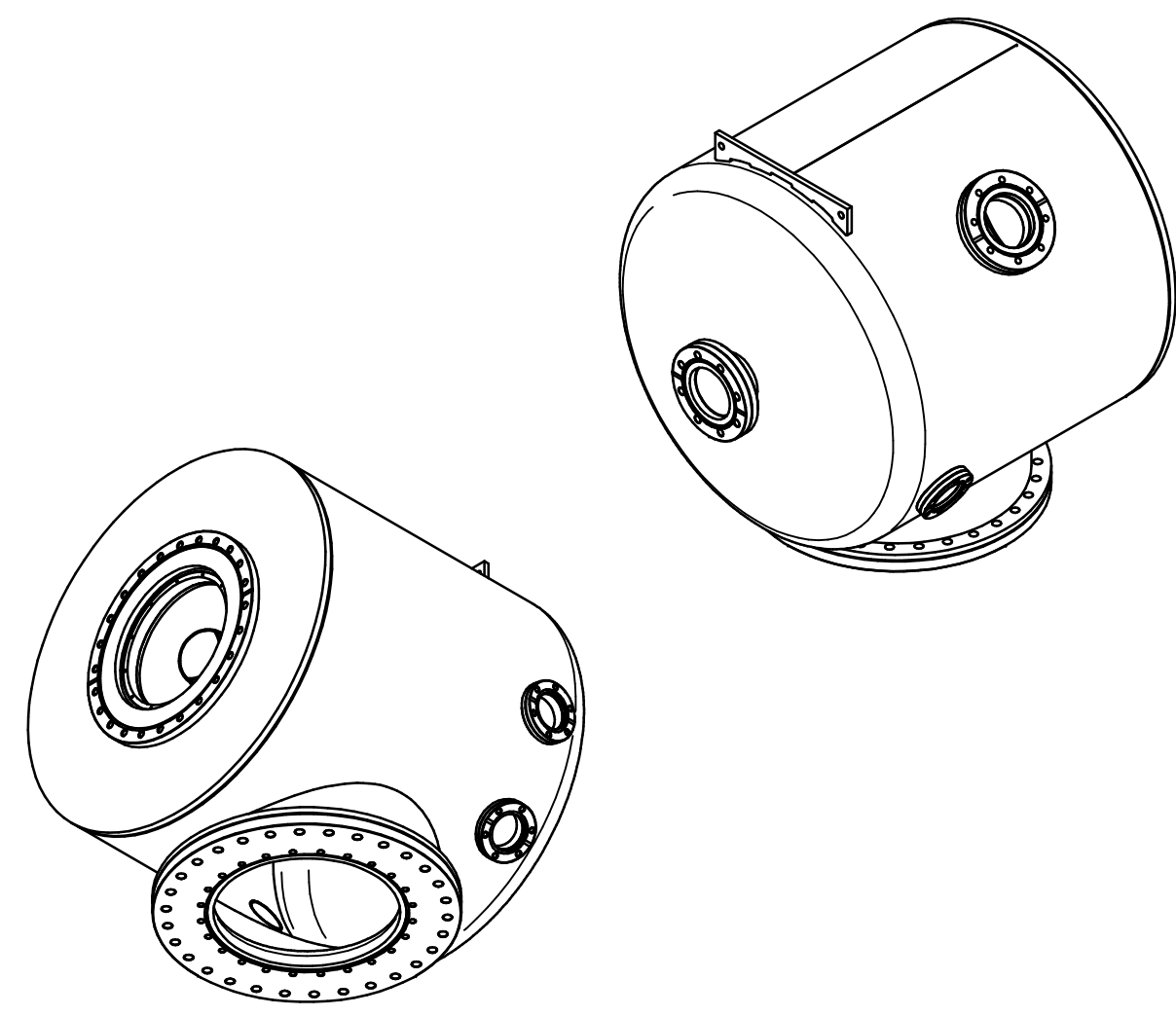
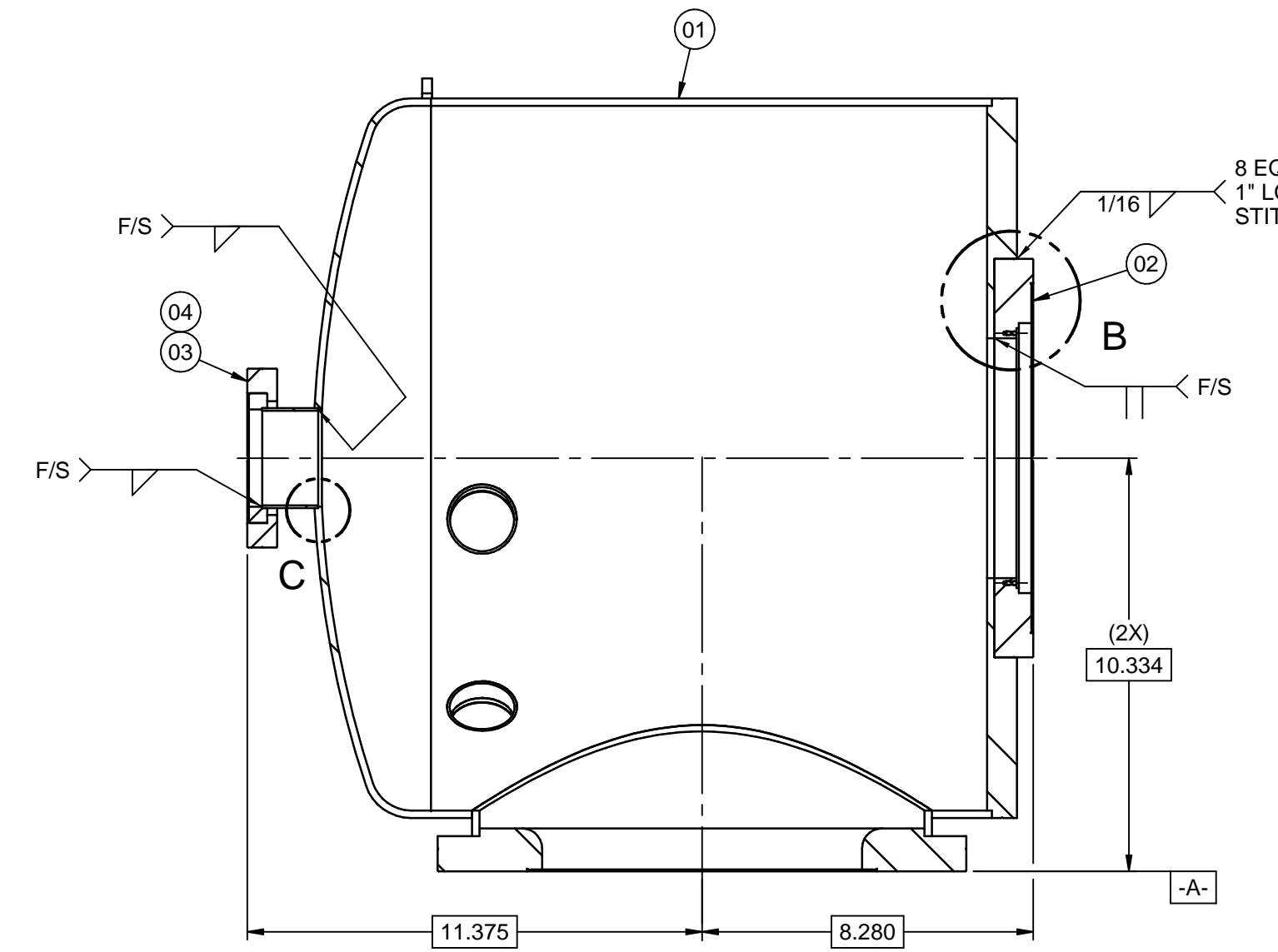

SECTION A-A

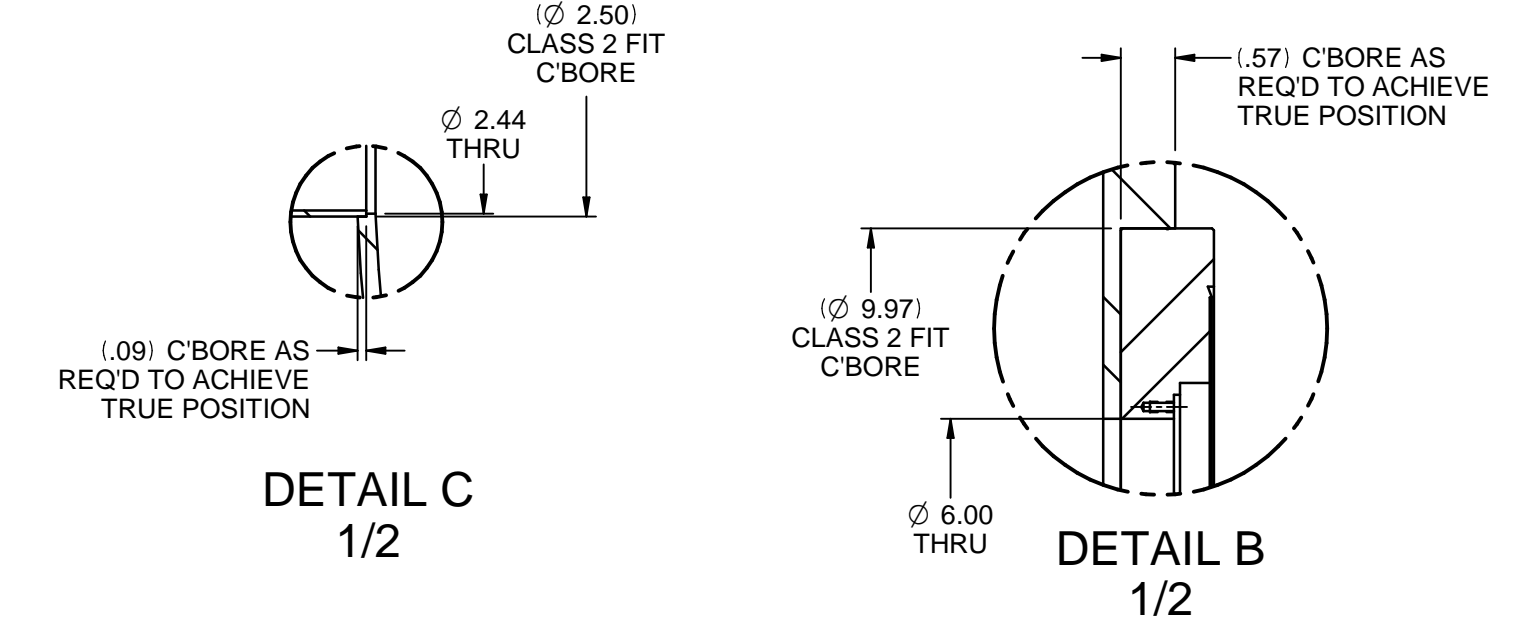

DETAIL C
1/2

DETAIL B
1/2

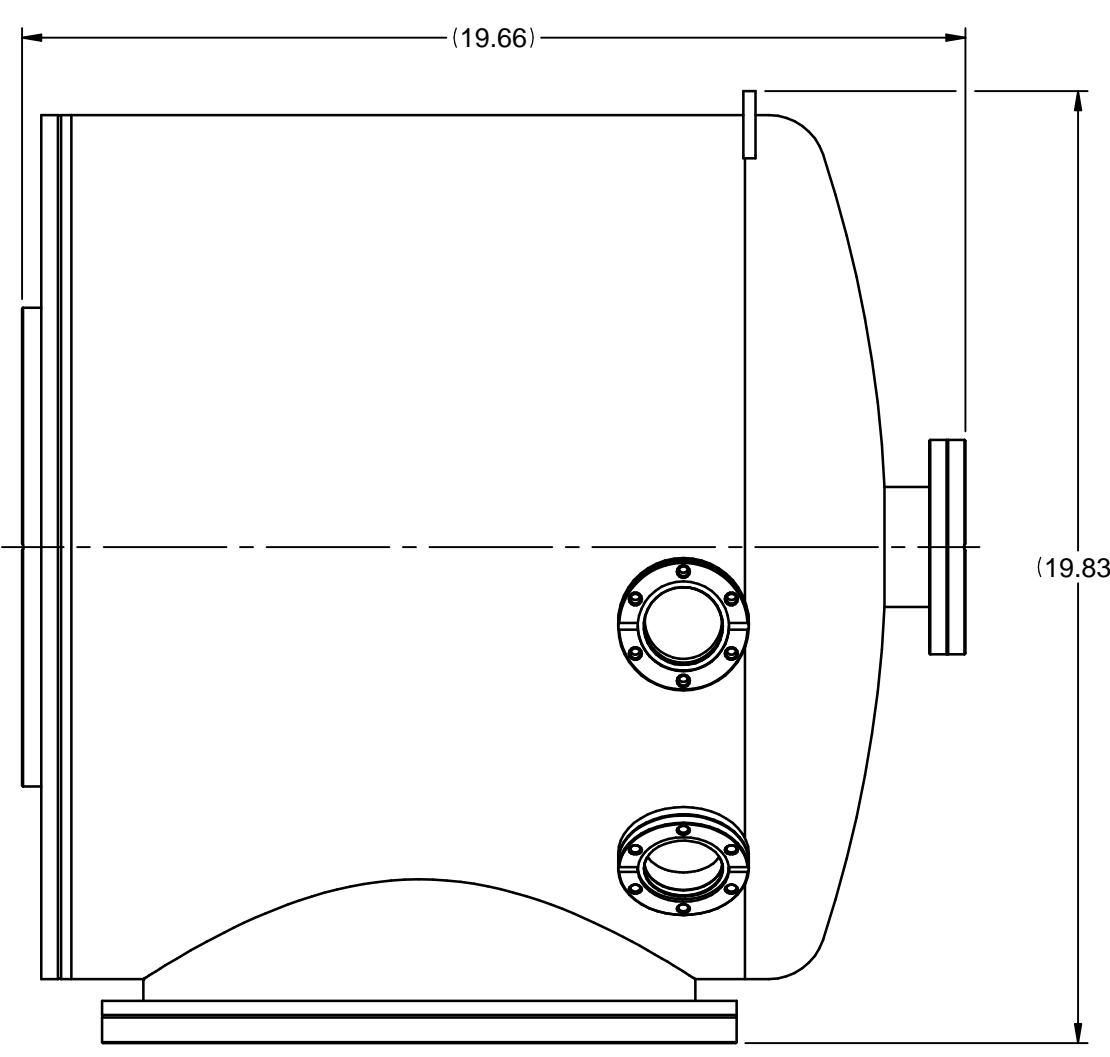

LEFT SIDE VIEW

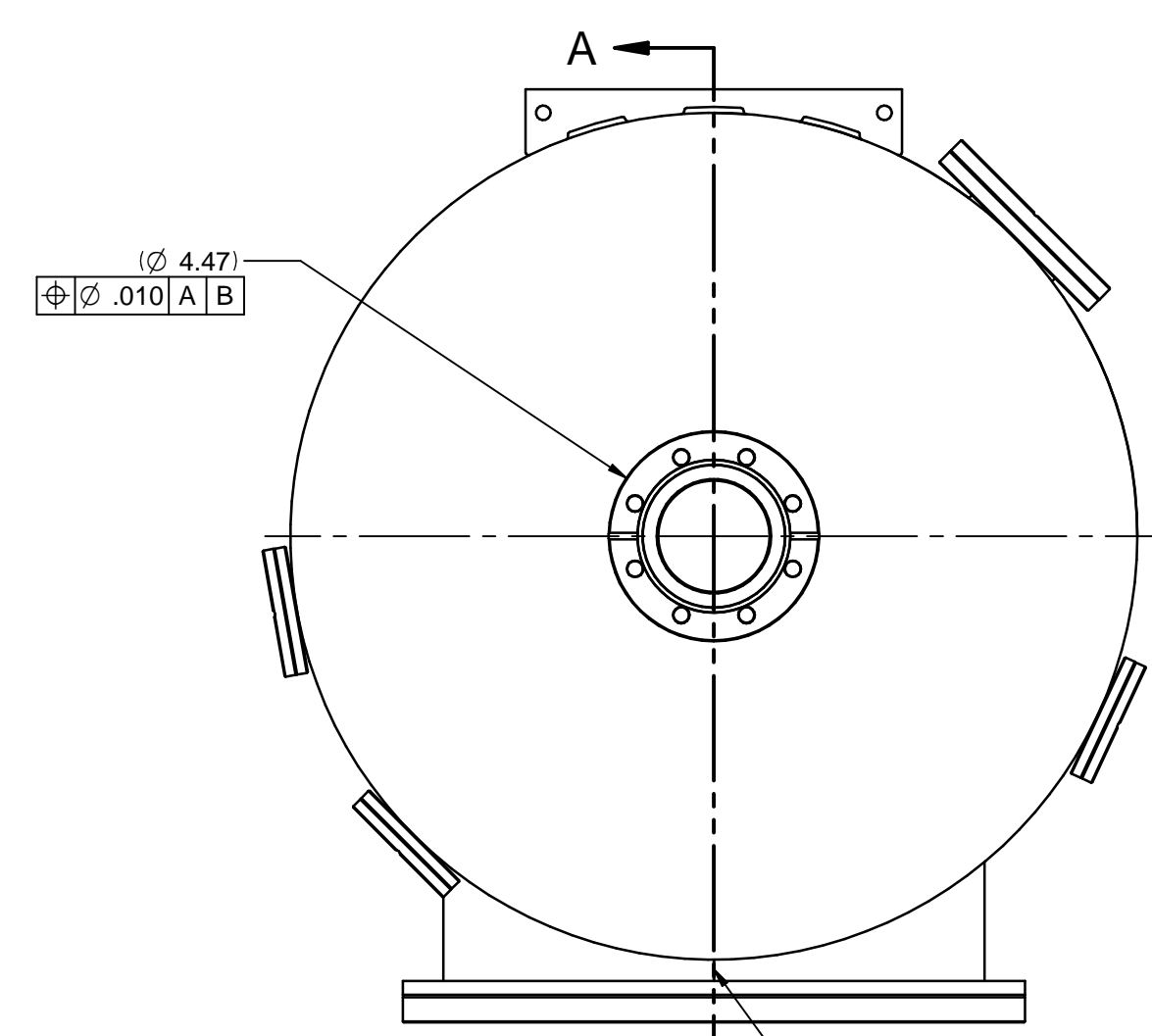

FRONT VIEW

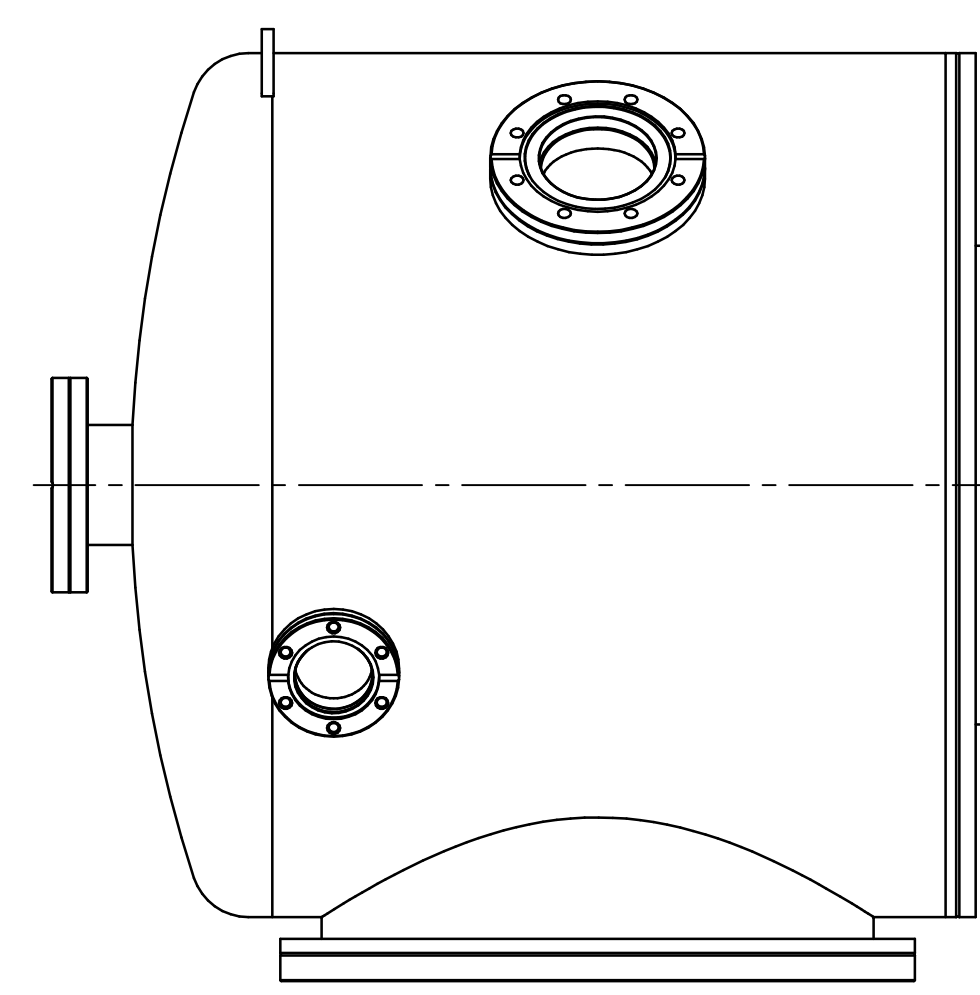

RIGHT SIDE VIEW

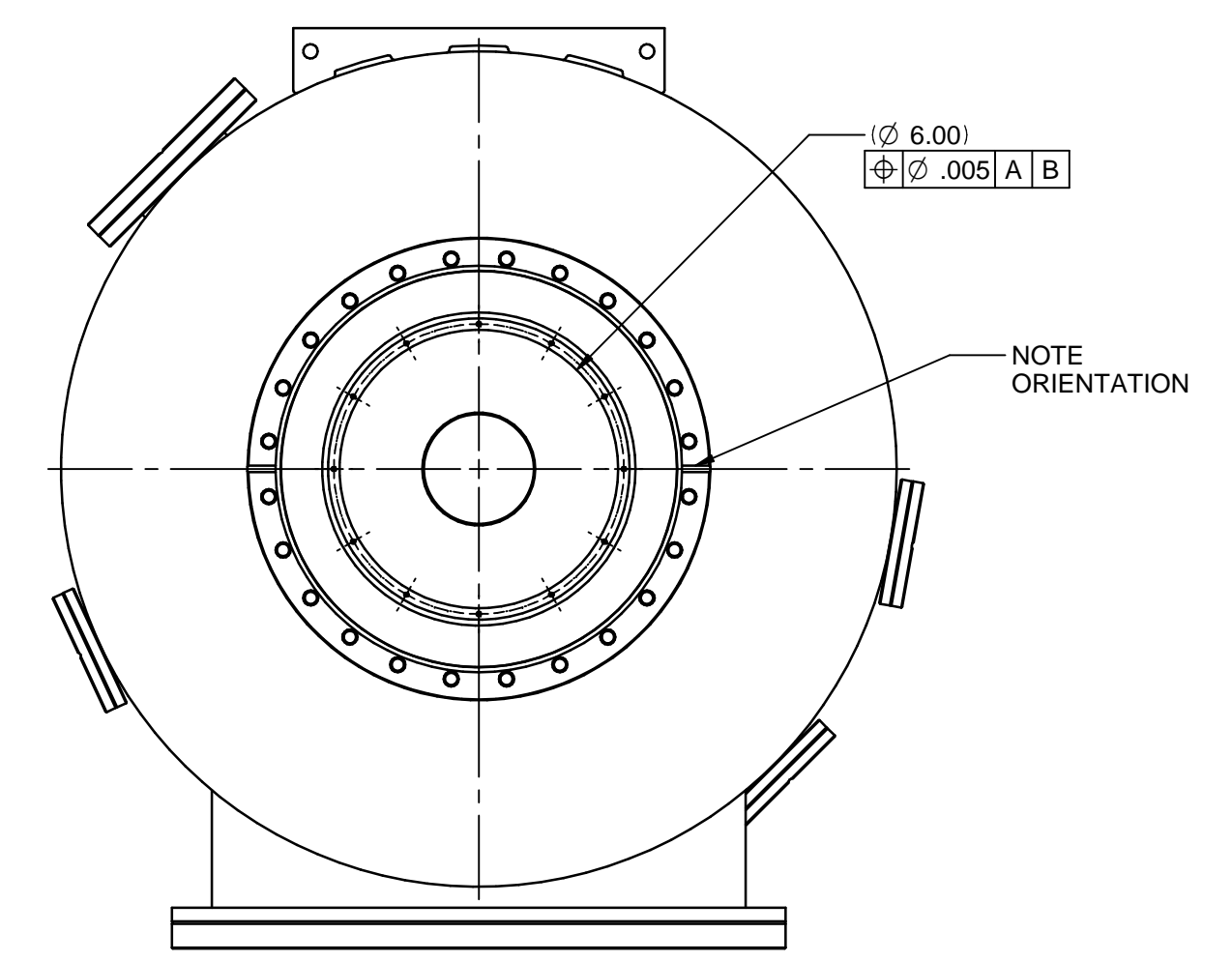

REAR VIEW

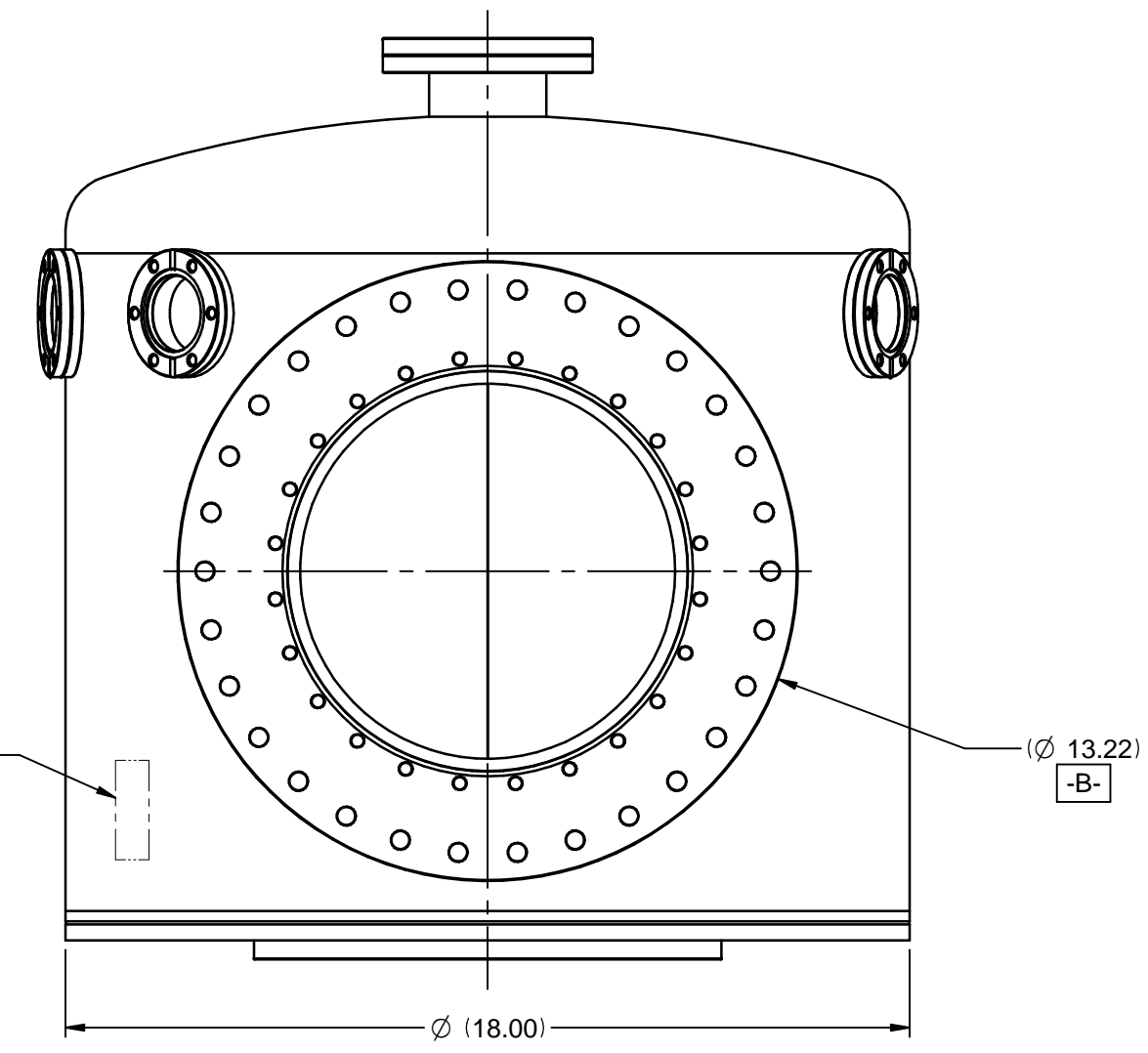

BOTTOM VIEW

- NOTES:
- ALL DIMENSIONS ARE IN INCHES, REFER TO TABLE 1 FOR STANDARD TOLERANCING INFORMATION.
 - ALL WELDS TO BE INTERNAL FULL FUSION VACUUM WELDS UNLESS OTHERWISE NOTED.
 - VACUUM WELDS TO BE LEAK CHECKED WITH A HELIUM MASS SPECTROMETER WITH A SENSITIVITY TO 2×10^{-10} STD CC/SEC FOR HELIUM DIMENSIONS FOR ALL PARTS LISTED IN THE BILL OF MATERIALS ARE NOMINAL.
 - ORIENT ALL FLANGES AS SHOWN.
 - VIBRA TOOL PART NUMBER "ACC-200-3000-0449 REV. -" IN APPROXIMATE LOCATION USING .25" HIGH CHARACTERS.

TUBE CUT TABLE			
TUBE P/N	LENGTH	QTY	CUT ALLOWANCE REQUIRED
SST-02501	1.40	1	

SYMBOL	LEGEND	DETAIL LEVEL:		CLEANING PROCEDURE:	
		MSW-DCP-116, LEVEL 3	MSW-DCP-101, LEVEL II	UNLESS OTHERWISE SPECIFIED TOLERANCES AND MANUFACTURING PRACTICES SHALL BE:	UNLESS OTHERWISE SPECIFIED ALL OTHER SURFACE FINISHES SHALL BE:
REVISION		N/A	AS SUPPLIED		
ITEM BALLOON					
FOCAL POINT					
FOCAL POINT DESIGNATOR					
INSPECTION BALLOON					
WATER TRACE IDENTIFICATION					
CENTER OF GRAVITY IDENTIFICATION					

NO.	ZONE	ECN #	REVISION DESCRIPTION	DATE	BY	CHK
A	ALL	-----	RELEASED FOR MANUFACTURING PER CUSTOMER DWG# ACC-200-3000-0449 REV. -	5/12/2014	SHP	DEC

1925 Route 51
Jefferson Hills, PA
15025-3681
phone: 1-800-245-1656
web: www.lesker.com

Kurt J. Lesker Company
"...vacuum science is our business"

1516 Burgess Road
Hastings, East Sussex, TN35 4NR
United Kingdom
phone: +44 01424 458100

NOTE: THIS DRAWING, AND ITS CONTENT, IS THE CONFIDENTIAL AND PROPRIETARY INFORMATION OF KURT J. LESKER COMPANY AND CAN NOT BE DISCLOSED OR USED EXCEPT WITH THE EXPRESS WRITTEN PERMISSION OF KURT J. LESKER COMPANY.

SCALE: FOR REFERENCE ONLY 1/4

APPROVED BY: ENR DATE: 5/9/2014

CHECKED BY: DEC DATE: 5/9/2014

DRAWN BY: SHP DATE: 5/5/2014

TITLE: BELL JAR, 18" OD, 17" OAL. 304L SS, 2B FINISH

SIZE: MATERIAL SPECIFICATION: D AS NOTED

DRAWING NO.: PRD118573-0500

REV: A

K/J/C PART NUMBER: BJ1817C00039

APPROX. WEIGHT: 138.8 lbs

SHEET: 1 OF 1