



PEM-90™ PHOTOELASTIC MODULATOR SYSTEMS
USER MANUAL

Part No. 145-0000-001

Hinds Instruments, Inc
3175 NW Aloclek Drive
Hillsboro, OR 97124-7135

All rights reserved No part of this book may be reproduced or transmitted in any form or by any means, electronic or mechanical, including photocopying, recording, or by any information storage and retrieval system without written permission from Hinds Instruments, Inc

Part No 145-0000-001

Printed in USA

© 1994, 1996, 1998 Hinds Instruments, Inc

W A R N I N G !

DO NOT turn on your modulator unless the optical head and the electronic head are connected by the blue interconnect cable.

SERIOUS DAMAGE MAY RESULT!

QUICK- REFERENCE

INTRODUCTION

1. PHYSICAL DESCRIPTION

2. OPERATION

3. TYPICAL OPTICAL BENCH SETUPS

4. CALIBRATION & MAINTENANCE

5. TROUBLESHOOTING

6. THEORY OF OPERATION

7. USER SUPPORT INFORMATION

8. BIBLIOGRAPHY

9. SPECIFICATIONS

APPENDICES

DET-90 PHOTODIODE DETECTOR/PREAMPLIFIER USER MANUAL

SCU-90 SIGNAL CONDITIONING UNIT USER MANUAL

CE DECLARATION OF CONFORMITY

TABLE OF CONTENTS

SHIPPING DAMAGE CHECK	IV
SETUP & OPERATION CHECK	V
1. PHYSICAL DESCRIPTION	1-1
A. MODULATOR HEADS	2
Transducer-Optical Element Assembly	2
Driver Circuit	4
B. THE CONTROLLER	5
The Front Panel	5
Rear Panel	6
Microprocessor and Digital Circuitry	7
Analog Circuit	8
Remote Operation	8
RS-232 Serial Interface	8
2. OPERATION	2-1
A. SETUP	1
Optical Setup	1
Electronic Setup	1
B. FRONT PANEL OPERATION	2
Power Up	2
Power Up to Factory Default Settings	2
Setting Front Panel Parameters	2
Setting the Wavelength	3
Setting the Retardation	3
Retaining Parameters	4
Other Front Panel Buttons	4
C. REMOTE OPERATION	4
Connection for Remote Operation	4
D. RS-232 SERIAL INTERFACE OPERATION	5
General User Interface	5
E. CONNECTING THE PEM OPTICAL AND ELECTRONIC HEADS	7
3. TYPICAL OPTICAL BENCH SETUPS	3-1
A. LINEAR & CIRCULAR DICHROISM	1
B. LINEAR BIREFRINGENCE	2
C. OPTICAL ROTATION	3
D. STOKES POLARIMETRY	4

4. CALIBRATION & MAINTENANCE	4-1
A. CALIBRATION	1
Adjustment of Peak Retardation Calibration	1
B. MAINTENANCE	1
5. TROUBLESHOOTING	5-1
A. RETARDATION/WAVELENGTH RETARDATION ENVELOPE	1
B. RESETTING THE CONTROLLER TO DEFAULT PARAMETERS	1
C. REFERENCE SIGNAL TEST	2
D. OPTICAL TEST	2
6. THEORY OF OPERATION	6-1
A. PRINCIPLES OF OPERATION	1
Retardation Effects of Compression and Extension	2
Quarter-Wave Retardation	2
Half-Wave Retardation	3
Symmetric Optical Element	3
B. MODES OF OPERATION	4
Use as a Modulator	4
Use as an Analyzer	4
7. USER SUPPORT INFORMATION	7-1
A. LIMITED WARRANTY	1
B. RETURN FOR REPAIR PROCEDURE	1
8. BIBLIOGRAPHY	8-1
9. SPECIFICATIONS	9-1
APPENDICES	A-1
A. CALIBRATION	A-III
B. MODULATED INTERFERENCE EFFECTS WITH LASERS	A-XI
C. LINEAR BIREFRINGENCE & OPTICAL ROTATION	A-XV
D. LINEAR & CIRCULAR DICHROISM	A-XXI
E. STOKES POLARIMETRY	A-XXV
DET-90 PHOTODIODE DETECTOR/PREAMPLIFIER	DET-1
SCU-90 SIGNAL CONDITIONING UNIT	SCU-1
CE DECLARATION OF CONFORMITY	BACK PAGE

SHIPPING DAMAGE CHECK

BEFORE YOU READ ANY FURTHER, please inspect all system components for obvious shipping damage. The PEM-90 is a precision instrument that can be damaged by rough handling. Your unit was packaged to minimize the possibility of damage in transit. Therefore, we recommend that you save the specially designed shipping container for any future shipment of your modulator unit. In particular, we recommend you save the internal packing materials for the optical head.

In the event your order arrives in damaged condition, it is important that the following steps be taken immediately. The title transfers automatically to you, the customer, once the material is entrusted to the transport company.

1. DO NOT RETURN THE INSTRUMENT TO HINDS INSTRUMENTS, INC. until the following steps are completed. Failure to follow this request will jeopardize your claim with the insurance company.
2. If a "Shock Watch" is present on the outer shipping container or anywhere inside, note the location and the condition of the shock watch. If the shipment receives handling rough enough to trigger the shock watch, the watch will turn red.
3. Open the container and inspect the contents. Do not throw away the container or any damaged parts. Try to keep all items in the same condition as originally received.
4. Notify the transport company immediately in writing, preferably by facsimile or telegram, about the shipping damage.
5. Wait for the transport company's representative to inspect the shipment personally.
6. After inspection, request Hinds Instruments' permission to return the damaged instrument by calling the Modulator Service Department at (503) 690-2000.
7. Return approved items to us at the following address:

Modulator Service Department
Hinds Instruments, Inc.
3175 NE Alcock Drive
Hillsboro, OR 97124-7135

8. After return permission is given and we receive the instrument, an estimate of the cost of repair will be sent to you in the event you choose to submit a claim to the transport company.

SETUP & OPERATION CHECK

Customers are urged to check out their modulator as soon as it is received. This section describes a simple functional test for the modulator. A kit containing two strips of Polaroid film for making the test is included.

The purpose of this test is to confirm that the PEM operates correctly when received. It is in the user's best interest, for warranty and shipping insurance reasons, to perform this test immediately when the PEM system is received.

Fasten Polaroid strips over aperture at 45 degrees to PEM optical axis.

Model I/FS50, II/FS42 Optical Heads

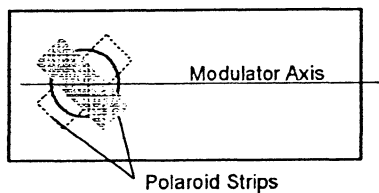

Model II/ZS37 Optical Head

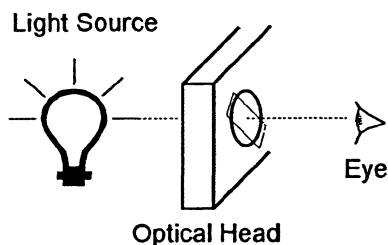
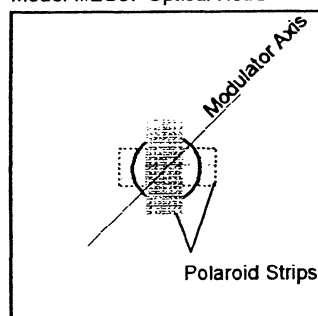

Looking through the modulator toward a light source.

ELECTRICAL SETUP

1. Connect the optical head and the electronic head together by means of the triaxial cable. **Operation of the modulator should never be attempted unless this connection has been made.**
2. Connect the electronic head to the controller using the cable provided. Connect the power cord to the controller and plug it into an AC power source.

OPTICAL SETUP

1. Using Scotch or other adhesive tape, fasten one Polaroid filter strip over the modulator aperture as shown at left. The strip should be oriented at approximately 45 degrees with respect to the modulator axis.
2. Looking through the modulator toward a light source (e.g. a light bulb; left) mount the second Polaroid filter strip on the other side of the optical head so that the light is "extinguished" and the aperture appears dark.

FUNCTIONAL TEST

1.
 - a) Check to see that the controller is OFF at the front panel.
 - b) Hold the UP ARROW key down and turn the controller power on.
 - c) Release the UP ARROW key.
 - d) Using the upper right hand button, select the nM indicator light under "WAVELENGTH." The number 632.8 should be displayed on the right hand display.
 - e) For Series I Modulators (I/FS50, I/CF50, etc.) press the $\lambda/2$ button. The left hand display should read 0.500.
 - f) For Series II modulators (II/FS42, II/ZS37, etc.) press the λ button. The left hand display should read 1.000.
2. Light from the bulb should appear through the aperture.
3. Push the INH button in the lower right-hand row of buttons. Light transmission should again be blocked, at least partially. Transmission can be restored by pushing INH again.

The above procedure is a functional test of the PEM-90. If this test is satisfied, the modulator is operating correctly. If further difficulties are experienced, contact the engineers at Hinds for assistance.

1. PHYSICAL DESCRIPTION

Figure 1.1 provides an overview of the PEM-90 photoelastic modulator system including the PEM-90 controller, optical head, and electronic head.

Figure 1.1. The PEM-90 Photoelastic Modulator System.

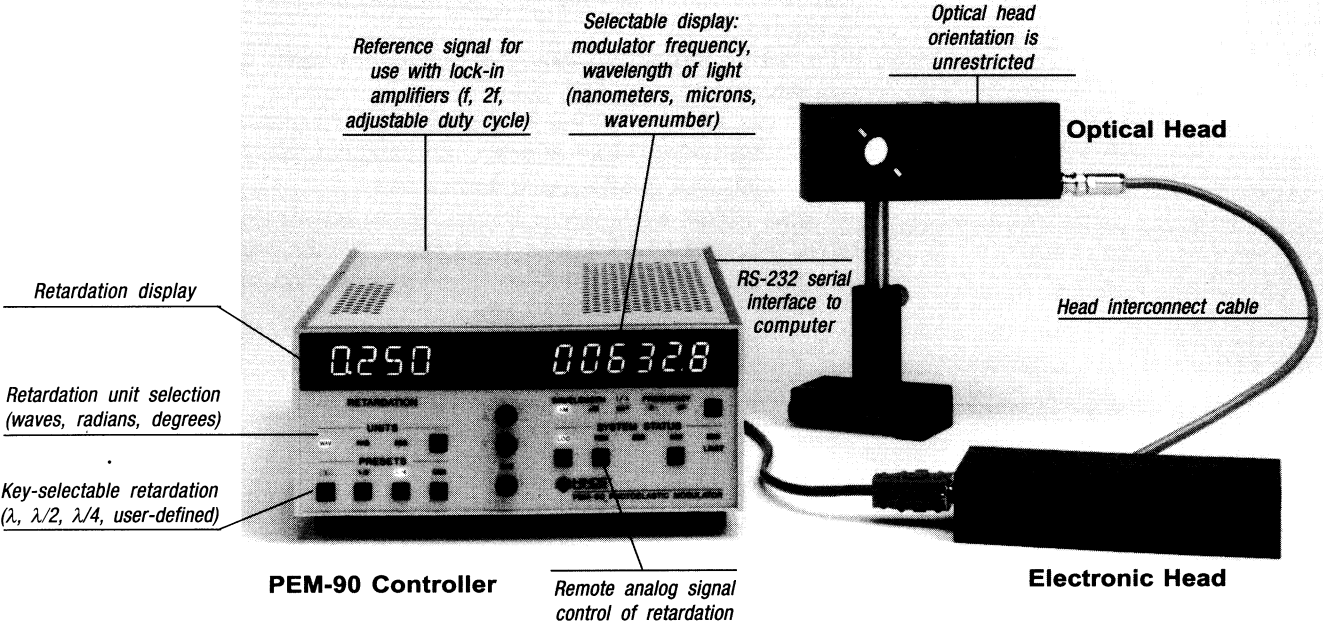
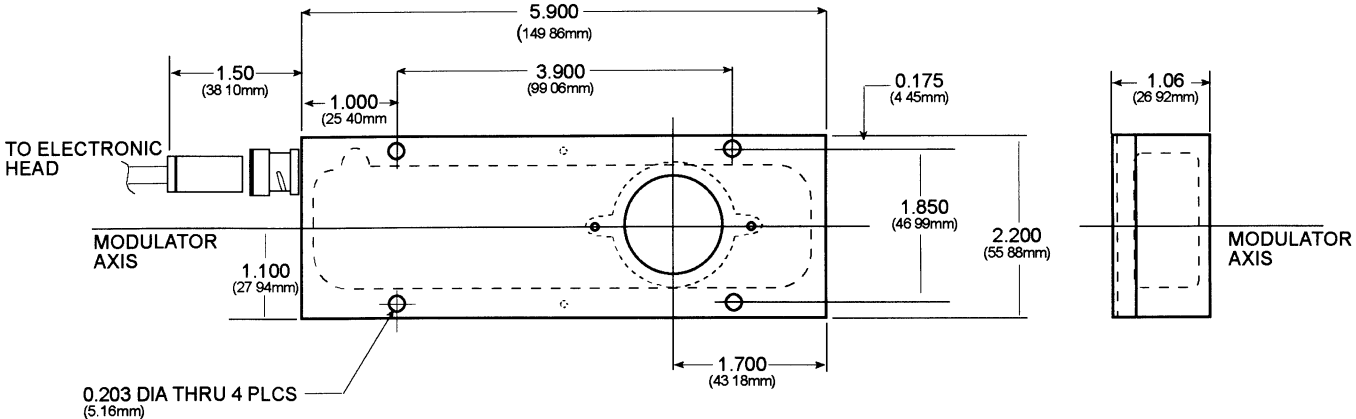

Figure 1.2. Model FS50 Optical Head Dimensions.



NOTE: One or two connectors may be used, depending on model.

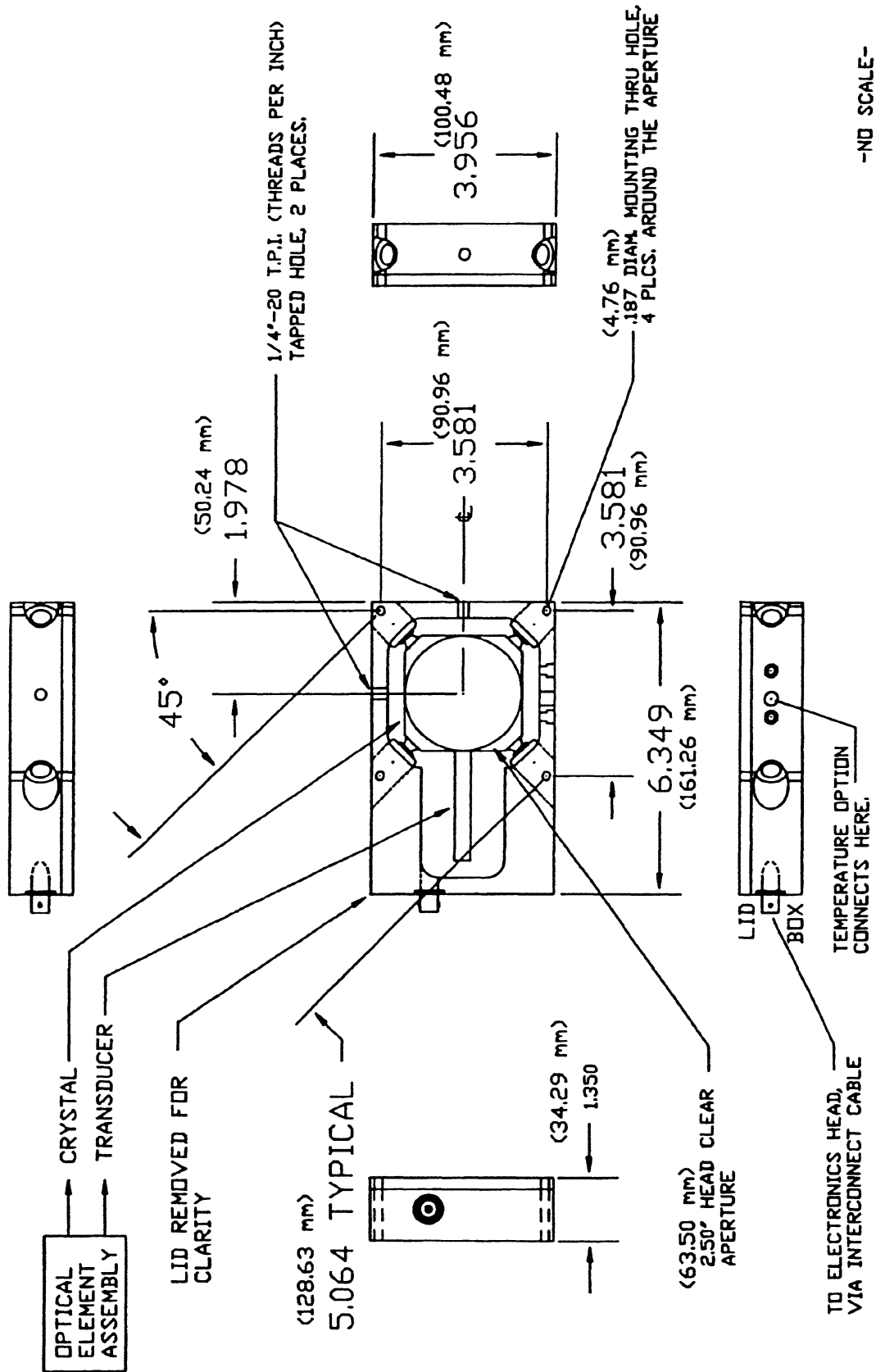

Figure 1.4. Model II/FS42 Optical Head Dimensions.

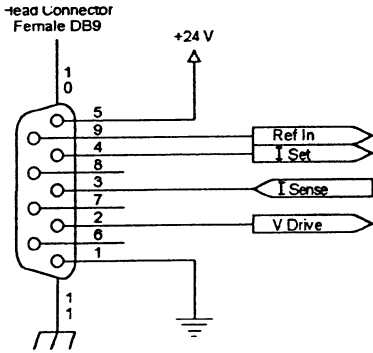

Figure 1.6. Head Connector Female DB9.

“electronic head”) by a triaxial cable or by dual coaxial cables. This assembly of the optical head, the electronic head, and the triaxial cable comprises the “modulator head,” which should be regarded as a single unit. **Operation of the electronic head without the cable and optical head connected should never be attempted. Such operation will almost certainly result in damage to the electronic head.**

Driver Circuit

The driver circuit consists of an active LC tank circuit connected in parallel to the optical assembly. The head-to-head triaxial cable contributes capacitance to the tank circuit. The driver circuit also generates a current feedback signal back to the controller.

The driver circuit receives 24-volt power, a DC current signal (VDRIVE) which establishes the peak retardation level, and a “feed-forward” current signal which stabilizes the peak retardation at the designated value. The driver board also transmits the (optional) head temperature signal back to the controller. Pinout of the cable between the controller and the electronic head is shown in Figure 1.6.

The driver circuit has two adjustments which are factory-set. These are the LIMIT potentiometer, which establishes the maximum peak retardation achievable by the modulator, and the RANGE potentiometer, which establishes the retardation calibration. Normally these adjustments would not be made by the user, unless *in situ* calibration of the modulator is desired.

Figure 1.5. Electronic Head Dimensions.

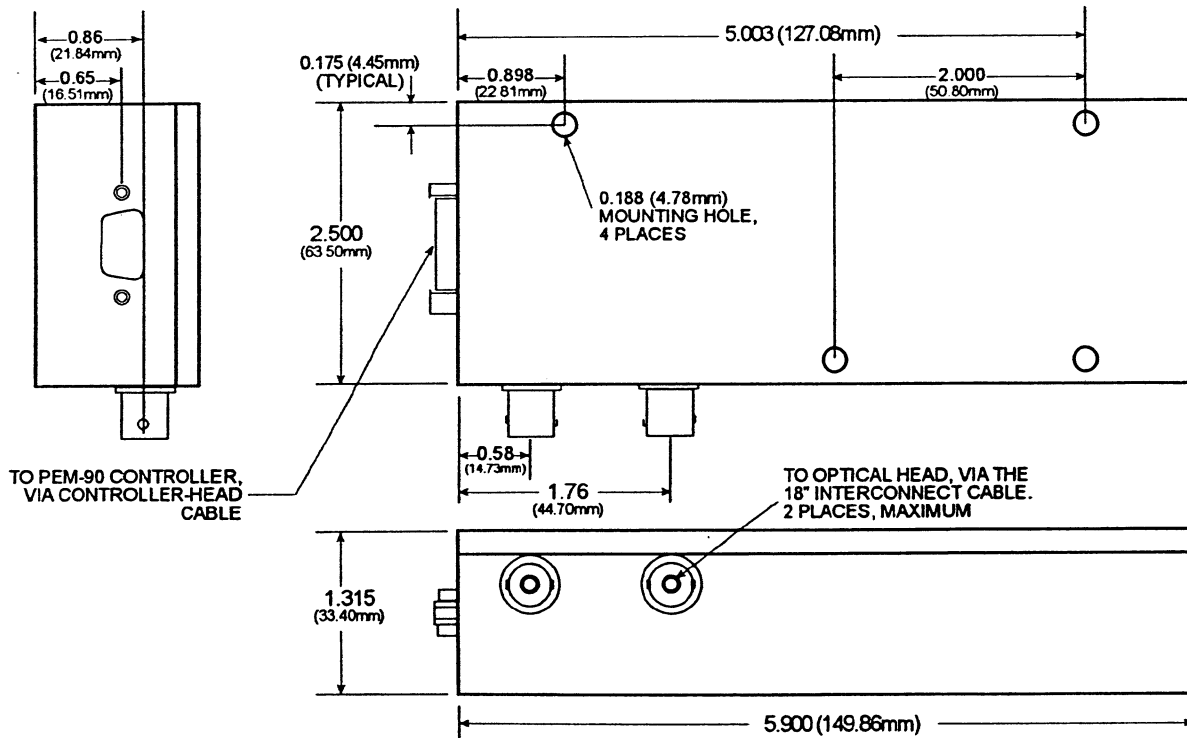

NOTE: One or two connectors may be used, depending on model.

B. THE CONTROLLER

The PEM-90 controller, as the name implies, controls the peak retardation setting of the modulator. Other functions include providing the interface with the user, either through the front panel, a computer (RS-232), or the REMOTE interface. The controller also generates two 0-5 volt square-wave TTL reference signals, one at the modulator operating frequency (f) and the other at twice the modulator operating frequency (2f).

The Front Panel

The front panel (Figure 1.7) provides the primary interface between the user and the modulator in the "manual" operating mode. It also indicates the parameters which may be monitored and controlled by a computer.

Wavelength and frequency display.

In the upper right corner of the panel is a six-digit display. The parameter displayed can be selected by the button and annunciator lights immediately below it. The button scans sequentially through the display selection. Parameters which can be displayed are:

- Wavelength (nanometers)
- Wavelength (microns)
- Wave number (waves per centimeter)
- Modulator frequency – f (kilohertz)
- Twice the modulator frequency – 2f (kilohertz)

Retardation display and control.

A four-digit LED display at the upper left of the front panel displays retardation and temperature. The parameter displayed is selected by the button and annunciator lights below it.

The middle row of lights and button on the left side of the panel selects the units of peak retardation to be displayed. The options are waves, radi-

Figure 1.7. PEM-90C Controller Front Panel.

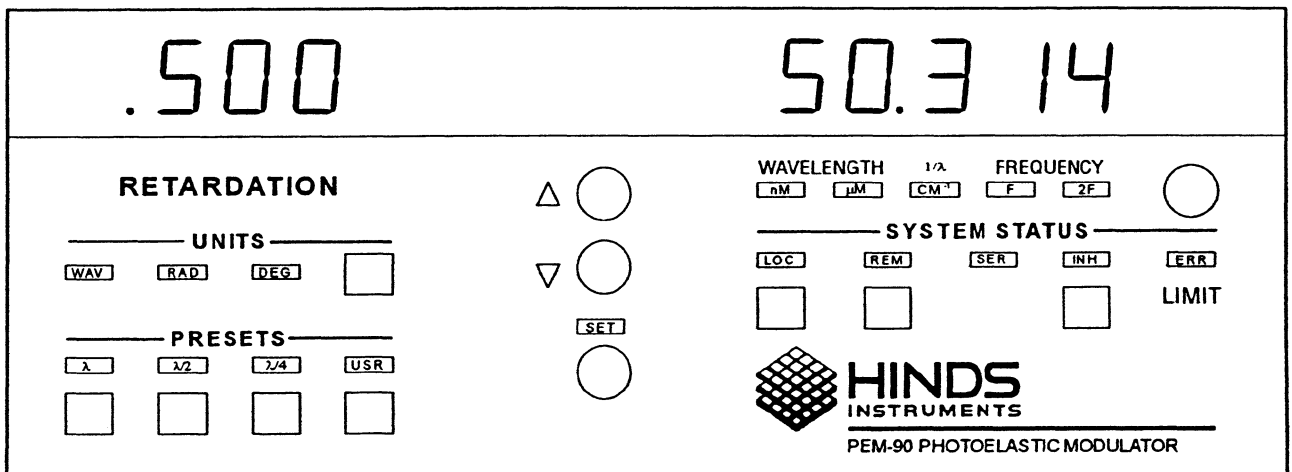

ans, and degrees. These are units of phase, and are all derived from the peak retardation in length units (nanometers or microns) and the wavelength. Consequently, the wavelength of the light being used must have been input to the controller for the retardation display to have meaning.

The bottom row of annunciator lights, each with its own button, is used for setting the peak retardation at predetermined values. Options are: full wave (λ), half wave ($\lambda/2$), quarter wave ($\lambda/4$), and a user-determined setting.

At the lower right of the front panel is row of annunciator lights and buttons marked "System Status." The five different modes of operation are described below.

LOC Local mode of operation. The modulator is being controlled from the front panel.

REM Remote operation. The modulator peak retardation is being controlled by an external analog signal (0 to 5 volts) input through the "remote" connector on the rear panel.

SER Computer operation. LED flashes to indicate serial data being received or transmitted from the PEM serial port.

INH Inhibit mode. The controller electronics are still on, but the retardation is set to a very low level. The button toggles this on and off.

LMT Limit mode. Indicates PEM is in limit condition.

Control buttons.

Three round buttons in the center of the front panel are the "control" buttons. They are used for setting the values of wavelength, peak retardation, and the user-selected retardation level from the front panel.

Rear Panel

All electrical/electronic connections to the controller are made to the rear panel. Refer to Figure 1.8. In sequence from left to right, the connections are

- IEC 320 power receptacle
- fuse
- RS-232C connector, DB9M
- f reference signal, BNC
- remote connector, 8-pin DIN
- 2f reference signal, BNC
- 2f duty cycle adjustment, dual trimpots
- head cable connector, DB9F

Microprocessor and Digital Circuitry

An Intel 80C31BH microprocessor is the heart of the digital circuit. It performs several functions, as listed below:

- Generates the digital signal which determines the modulator peak retardation.
- Communicates with the front panel, receiving input signals and controlling the display.

Figure 1.8. Controller Rear Panel.

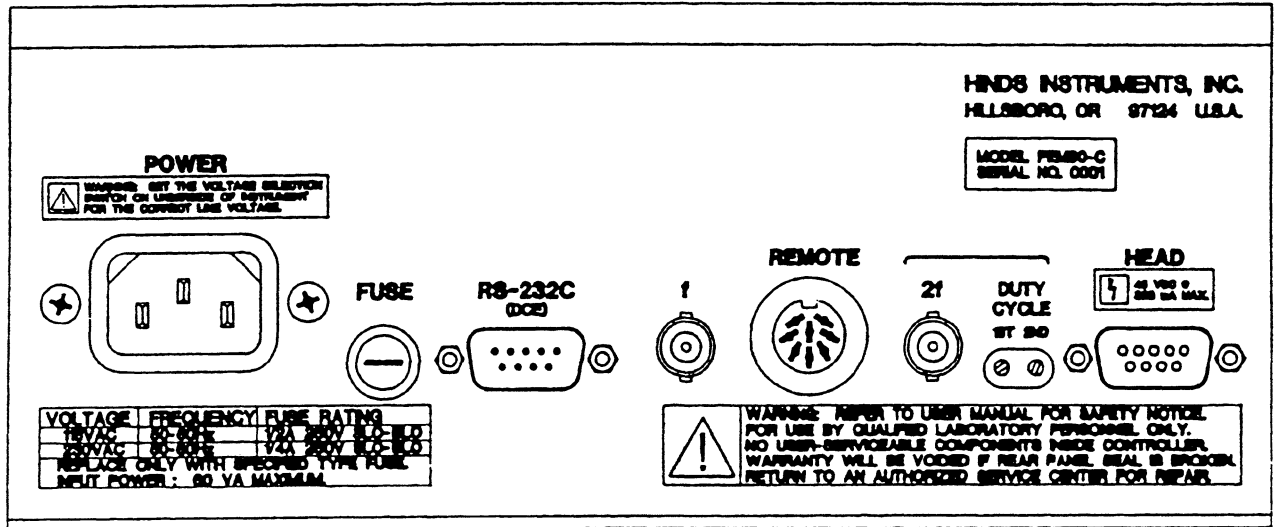

- Communicates with a PC-type computer, through the RS-232 serial port.
- Computes derived modulator operating parameters (e.g. retardation in units of waves)

The microprocessor drives an 8-bit parallel bus on which reside:

- D/A converter (AD7248JN) which generates the retardation “control” signal from the digital retardation signal generated by the processor. A mechanical relay selects between the processor-generated control signal and the remote input control signal.
- The system EPROM (27C256) which stores the controller operating program.
- The 8255 integrated circuit which communicates with the display.

The processor also drives a serial bus on which reside:

- The EEPROM (93C46) which stores the controller operating parameters and the limit condition when power is removed. This enables the modulator to return to the previously set operating parameters on power up.
- An A/D converter which converts the remote input voltage, the control voltage, and the limit condition signal.

The processor also provides an RS-232 port (0-5 v. TTL).

Analog Circuit

The analog portion of the controller receives the following inputs:

- The retardation control signal (microprocessor or remote input control signal as determined by the processor-driven relay).
- A current feedback signal from the modulator head.

Figure 1.9. Remote Retardation Control Using an External Analog Signal.

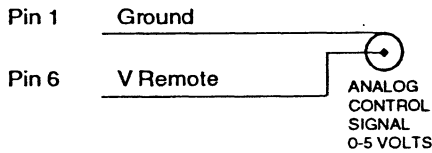

Figure 1.10. Remote Retardation Control Using a Multi-Turn Potentiometer.

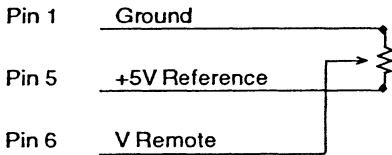
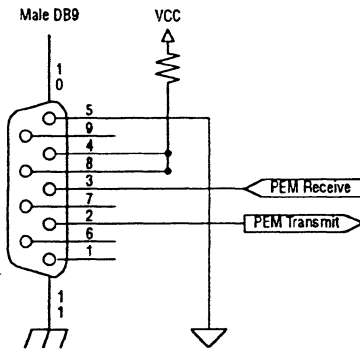

Figure 1.11. Serial Port Connector Male DB9.



The analog circuit generates a current “drive” signal from the control signal. The analog circuit also generates a current “feed-forward” signal, derived from the current feedback signal to the head. This is used to stabilize the retardation level of the modulator head.

The current feedback signal is also used to generate a 0-5 volt TTL square wave reference signal at the modulator frequency (f). This in turn is used to generate a reference signal at twice the modulator frequency ($2f$). The duty cycle of the $2f$ reference signal is user-adjustable. The f and $2f$ signal frequencies are monitored for display on the front panel.

Remote Operation

The modulator peak retardation can be controlled by an external analog signal through the remote input. This can be either a 0-5 volt signal from another device (Figure 1.9) or it can be generated with a multi-turn potentiometer using a 5-volt reference supplied in the remote connector, as shown in Figure 1.10. Other controller analog outputs from this connector include f and $2f$ reference signals, and the limit status. The inhibit condition of the controller may be toggled by a switch or a TTL signal from the remote connector cable.

RS-232 Serial Interface

An RS-232 Serial Port is supplied standard with each PEM-90C controller. The connector is a male DB9, and the connections are given in Figure 1.11 at left. This interface allows complete computer control over the modulator, as well as complete monitoring of all controller operating parameters displayed on the front panel.

2. OPERATION

A. SETUP

The optical bench and electronic instrument configuration depend on the particular application required for the modulator. Refer to Section 3, Typical Optical Bench Set-ups, for guidance. (More detailed set-up information may be found in the application notes in the Appendix.)

Optical Setup

The most common optical and electronic setup for checkout and calibration of the modulator is shown in Figure 2.1. This shows a monochromatic light source (such as a laser) or multiwavelength source with a wavelength selection device (e.g. monochromator).

The light source, if unpolarized, is followed by a polarizer at 45 degrees with respect to the horizontal, the modulator with its axis horizontal (0 degrees), a second polarizer (often called the analyzer) at -45 degrees, and a detector.

Electronic Setup

For simple checkout, Figure 2.1 shows the basic electronic requirements. Most light sources will require an electrical power supply, not discussed here. The detector is shown supplying a signal to the oscilloscope, with the controller reference signal connected to the oscilloscope trigger input.

The detector circuitry deserves some special comment. Care must be taken to ensure adequate frequency response, typically several times the PEM operating frequency. In many, if not most cases, this means using a preamplifier closely coupled to the detector to provide current-to-voltage conversion and signal impedance matching to the coaxial cable to the oscilloscope.

Grounding. The analog and digital grounds of the PEM-90 are not terminated to the chassis ground. This has been done to give the experimenter maximum flexibility in avoiding ground loops and other problems. (In most applications, this ground connection will be made in other instruments.)

There is provision on the circuit board for making this connection. The location is R1 and it is in the right rear corner of the circuit board. Typical connections would use either a 100-ohm resistor or a jumper wire.

There is provision on the circuit board for making this connection. The location is R1 and it is in the right rear corner of the circuit board. Typical connections would use either a 100-ohm resistor or a jumper wire.

Figure 2.1. Block Diagram for Oscilloscope Calibration Method.

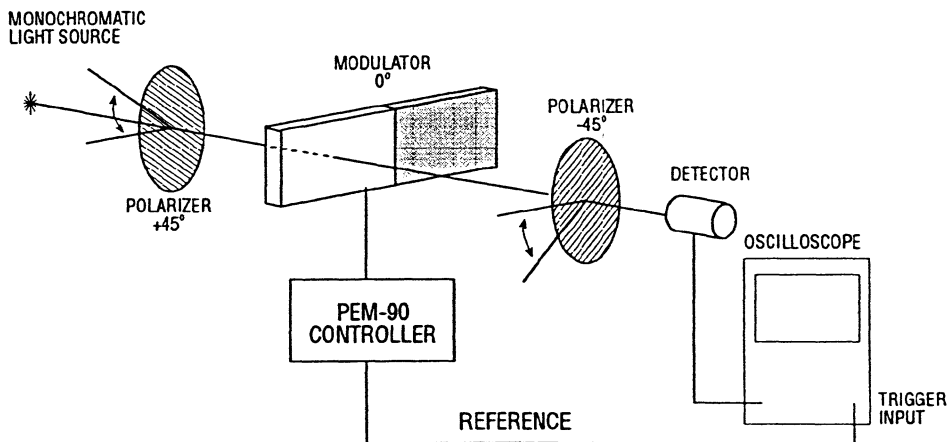

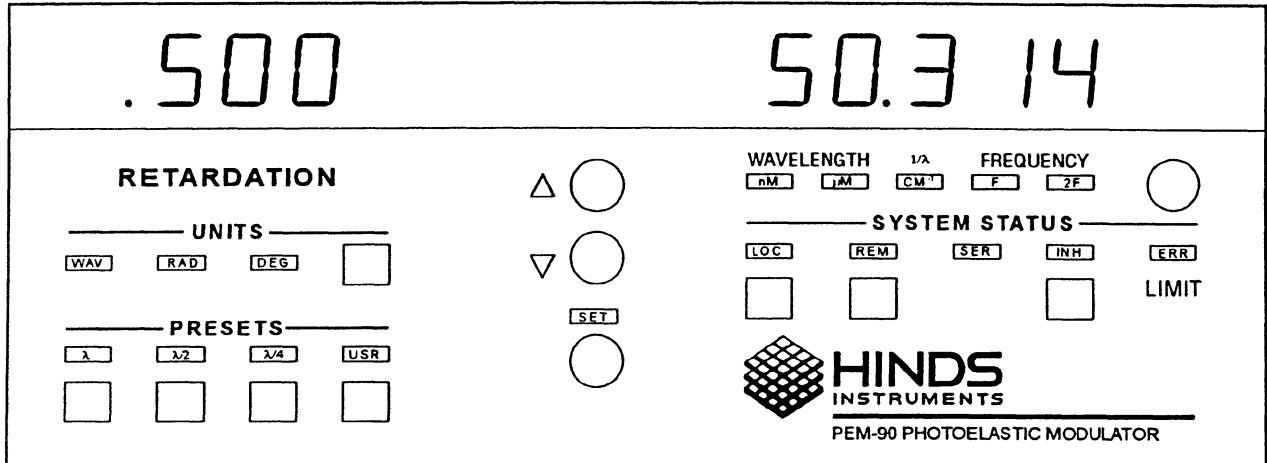

Figure 2.2. PEM-90C Controller Front Panel.

B. FRONT PANEL OPERATION

The following operating parameters may be set at the controller front panel. Refer to Figure 2.2 above.

- Wavelength of light (input to controller)
- Peak retardation
- Units of retardation displayed (waves, radians, degrees). Sequentially selected by the square button at left center.
- Display of wavelength of light, wave number, or modulator frequency (f or 2f). Sequentially selected by the round button on the right.
- Operating mode of the photoelastic modulator (LOC, REM, INH or ERR, but not SER). Selected by the square button under each annunciator light. SER operation mode must be selected through a computer.

Power Up

When the instrument is turned on by pushing the ON-OFF switch, the controller is powered up with the parameters which were set when the controller was turned off. When turned off, these parameters were stored in the EEPROM.

Note: Allow at least five seconds after turning off the power before turning the power on again. If a computer is used to turn the power on and off, this time delay must be programmed in.

Power Up to Factory Default Settings

If the UP-arrow is depressed when the controller is turned on, the controller will come up with the factory default settings of wavelength 632.8 nanometers and retardation 0.000 waves. The modulator frequency, f, is displayed and the operating mode is LOC.

Setting Front Panel Parameters

Setting the parameters of wavelength and retardation may be accomplished using the vertical row of round buttons in the center of the front panel. These include an UP button, a DOWN button, and a SET button.

Pressing the SET button once causes the UP and DOWN lights to come on and the WAV indicator to flash, and allows changes of retardation to be made using the UP and DOWN buttons. Pressing the SET button a second time causes the nM indicator to flash, and allows the wavelength to be set using the UP and DOWN buttons. Pressing the SET button a third time returns the controller to its normal operating mode, with the new values of retardation and wavelength.

If these parameters are to be retained when the controller is turned off, cycle through the SET button sequence once more.

Specific values of retardation, such as quarter-wave, also may be set using the lower-left row of square PRESET buttons.

Setting the Wavelength

For most experimenters, the most useful units of retardation are phase units (waves, radians, and degrees). The controller requires the user to input the wavelength of light being used so that the proper electrical signal may be sent to the modulator head.

The factory default wavelength is 632.8 nanometers. To set the controller for another wavelength use the following procedure:

- Select the nM display mode for the right-hand display. Wavelength in nanometers will be displayed on the right LED display.
- Press the SET button twice. The nM light should flash.
- Use the UP-arrow or DOWN-arrow buttons to adjust the wavelength to the desired value in nanometers.
- Press the SET button once more. No front panel light should be flashing.

Setting the Retardation

To indicate retardation on the left LED display the WAV light must be lit. Press the upper left button in sequence until this occurs.

Selecting units for retardation.

The middle left row of lights indicates WAV (waves), RAD (radians) or DEG (degrees). The square button scans through these options.

Setting the retardation (arbitrary values).

- Press SET once. The RET light should flash.
- Use the UP-arrow key to increase the peak retardation, the DOWN-arrow key to decrease the retardation.
- When the correct level of retardation has been reached, press the SET key twice.
- No lights should flash on the front panel. The retardation is now set at the desired value, and this value should be displayed in the left-hand LED display.

Setting the retardation (fixed values).

- Quarter-wave retardation. Press $\lambda / 4$.
- Half-wave retardation. Press $\lambda / 2$.
- Full wave retardation. Press λ .
- User selected fixed value of retardation. Press USR. (This selects a user-determined value of retardation. See below for programming the value of this setting.)

Setting the “user-selected” value of retardation.

- Select USR in the lower left row.
- Press SET once. The WAV light should flash.
- Use the UP-arrow and DOWN-arrow buttons to adjust the retardation to the desired value.
- Press the SET button twice.
- No front panel lights should be flashing. The modulator retardation will be set to this pre-selected value each time the USR button is pressed.

Retaining Parameters

To ensure that these parameters will be retained even when the controller is turned off, cycle through the SET button sequence once again.

Other Front Panel Buttons

The use of the lower right row of buttons and indicators is described below. Additional details on the REM and SER indicator follow.

LOC Local mode of operation. The modulator is being controlled from the front panel.

REM Remote operation. The modulator peak retardation is being controlled by an external analog signal (0 to 5 volts) input through the “remote” connector on the rear panel.

SER Computer operation. LED flashes to indicate serial data being received or transmitted from the PEM serial port.

INH Inhibit mode. The controller electronics are still on, but the retardation is set to a very low level. The button toggles this on and off.

LMT Limit mode. Indicates PEM is in limit condition.

C. REMOTE OPERATION**Connection for Remote Operation**

Connection for remote operation is made through a cable attached to the Remote Input (8-pin Circular DIN connector). The wiring for this connector is described in Figure 2.3. See also Figures 2.4 and 2.5.

The modulator peak retardation can be controlled by either of two methods:

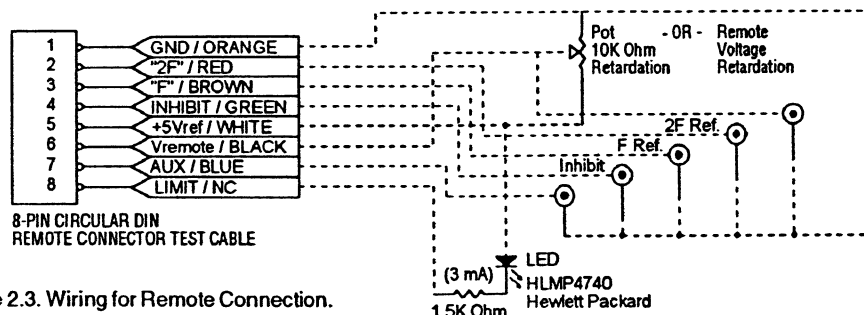

Figure 2.3. Wiring for Remote Connection.

Figure 2.4. Remote Retardation Control Using an External Analog Signal.

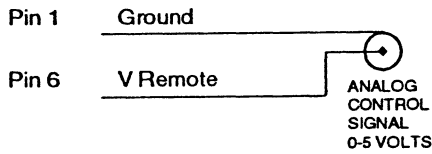

Figure 2.5. Remote Retardation Control Using a Multi-Turn Potentiometer.

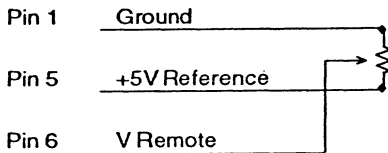
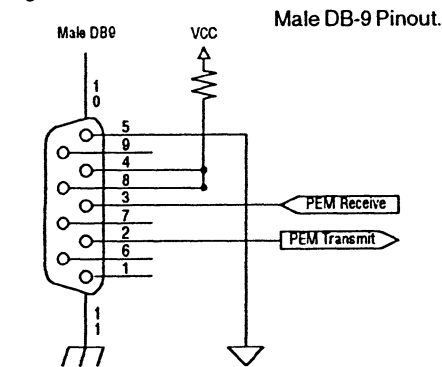

TABLE 2.1. RS-232 CONFIGURATION	
Word length	8
Parity	No
Baud Rate	9600
Stop Bits	1
Handshake	no

Figure 2.6. PEM Controller Serial Port,



Query Mode
R<CR>
0500

Parameter Set Mode
R:0250
0250

1. A 0-5 volt signal can be connected between pin 1 (ground, orange wire) and pin 6 (V_{REMOTE} , black wire). The modulator retardation will be linearly dependent on the signal voltage. For Series I modulators such as FS50, a 5-volt signal will give half-wave retardation at 1000 nanometers. (Figure 2.4.)
2. A 1-kohm potentiometer can be connected between pin 1 (ground, orange wire) and pin 5 (V_{REF} , white wire). The wiper of the potentiometer should be connected to pin 6 (V_{REMOTE} , black wire). The modulator retardation will then be dependent on the potentiometer wiper setting. (Figure 2.5.)

For additional sensitivity and precision in setting the retardation, the user may wish to use a multi-turn potentiometer in their interface to the REMOTE connector.

Other connections to the remote input are:

- Pin 2 (red wire) carries the “2f” reference signal.
- Pin 3 (brown wire) carries the “f” reference signal.
- Pin 4 (green wire) controls the INH (inhibit) function. A 5 volt signal initiates INH, return to 0 volts returns operation to REM (remote).
- Pin 8 carries the modulator limit condition. It may be connected to an LED according to Figure 2.3. A lit LED indicates that the modulator is in “limit.”

D. RS-232 SERIAL INTERFACE OPERATION

The PEM-90 offers a standard RS-232C communications interface port. This communications port operates at 9600 baud. Refer to Table 2.1. at left for RS-232 configuration. The connector interface is a standard DB-9 connector. Figure 2.6. shows the pinout. It is configured for straight through connection. Do not use a null modem cable with this interface.

General User Interface

1. All commands are ASCII upper case characters from 1 to 4 characters.
2. All command parameters are preceded by a colon and contain either ASCII numbers or characters. *Leading zeroes must be included.*
3. Command syntax, see Figure 2.7.
4. When a command is terminated by a “CR” ASCII (13) then the command is executed.
5. If the command is entered as just ASCII upper case characters without any punctuation (i.e. colons), then the current parameter setting is echoed back (example at left). This is called “query mode.”
6. If the command is entered as ASCII upper case characters with a colon followed by ASCII numbers, then the parameter is being set (example at left). The new parameter setting is then echoed back. This is called “parameter set mode.”

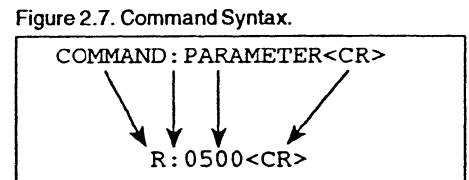

7. For high speed communications, it is recommended that the echo be turned off by issuing the echo command (e.g., E:1<CR>)
8. System commands and operating commands are summarized in Table 2.2 for the RS-232 interface.

TABLE 2.2. COMMAND LIST

System commands:

E:n ----- Character echo to remote device
 n = 0 or 1; 0=echo, 1=no echo

Z ----- Reset instrument to factory default
 (returns start-up header, and/or error code (s))

Operating commands:

F ----- Read F reference frequency (read only)

2F----- Read 2F reference frequency (read only)

I:n----- Inhibit retardation
 n = 0 or 1 — 0=normal operation, 1=inhibited

R:nnnn----- Set retardation in wave units
 nnnn = 0000 to 1000

W:nnnnnn ----- Set wavelength in nm units
 nnnnnn = 00000.0 to 19999.9

R ----- Retardation, query

W ----- Wavelength, query

E. CONNECTING THE PEM OPTICAL AND ELECTRONIC HEADS

If there is a single, triax BNC connector, just hook the triax cable provided between the two heads. The triax cable is typically blue. If there are two standard BNC (coax) connectors, connect the two coax cables provided from the optical head to the electronic head as shown in Figure 2.7. The coax cables are typically black.

Figure 2.7. Normal Connection
Note: Optical head packaging represents a typical system; your head may be different.

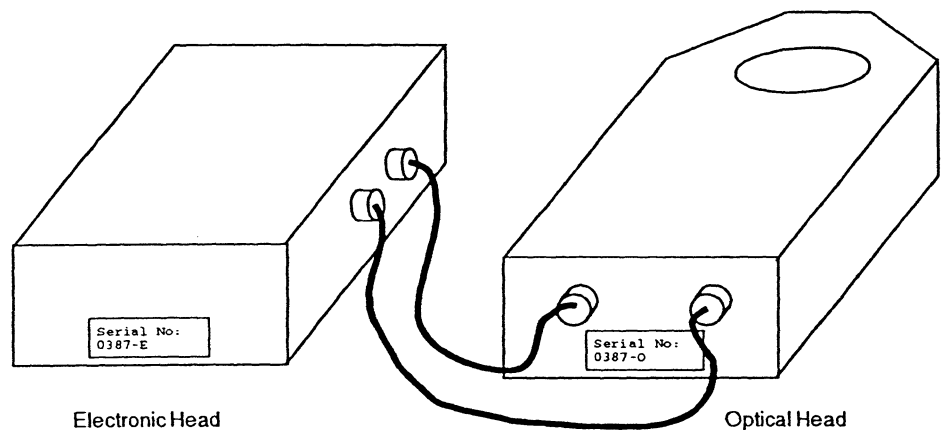

If the cables are connected 'crossed' as shown in Figure 2.8, the instrument will operate correctly, except that the phase relationship between the optical retardation signal and the phase reference outputs will be inverted. For many applications this is not a problem, or can be used as a diagnostic tool when tracing the signal path in a system.

Figure 2.8. Crossed Connection

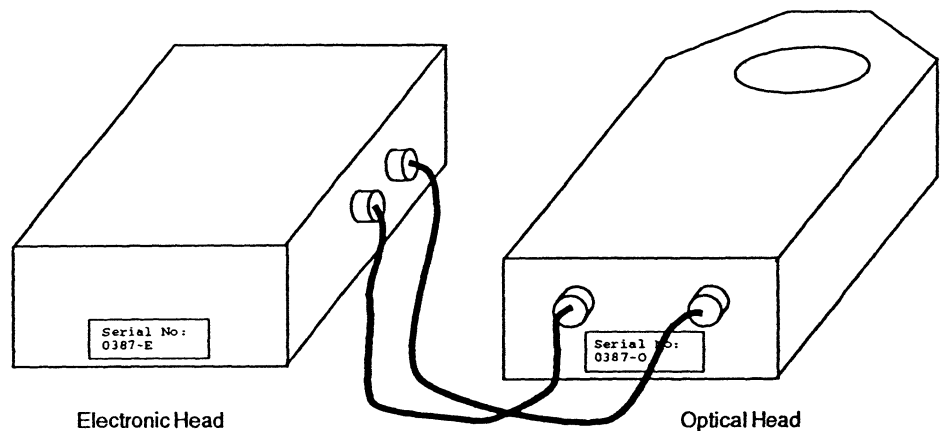

Finally, connect the electronic head to the controller. **Do not apply power to the controller if the electronic and optical heads are not connected to each other, as the circuitry can be damaged!**

3. TYPICAL OPTICAL BENCH SETUPS

A. LINEAR & CIRCULAR DICHROISM

Linear dichroism (LD) is the differential absorption between two components of linear polarized light at right angles to each other. An experimental apparatus for measuring LD is shown in Figure 3.1. The sample has been rotated about the optic axes so that the dichroic axes are at 45 degrees to the modulator axis.

Detector output is an electrical signal whose average DC voltage is proportional to the amount of light reaching the detector. The LD effect is proportional to the AC signal at 2f divided by the DC detector signal.

$$LD \propto \frac{V_{2f}}{V_{DC}}$$

Circular dichroism (CD) is the differential absorption between left and right components of circular polarized light. The apparatus for measuring CD is also shown in Figure 3.1, except that orientation of a CD sample is not important.

The CD effect is proportional to the AC signal at the modulator frequency f divided by the DC detector signal.

$$CD \propto \frac{V_f}{V_{DC}}$$

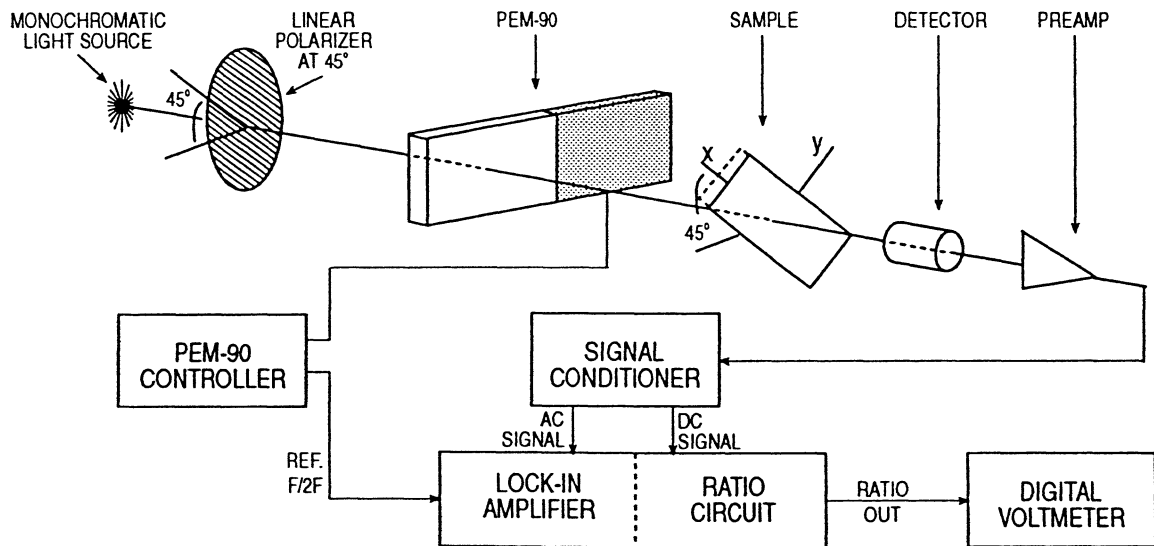

Figure 3.1. Linear and Circular Dichroism Setup.

B. LINEAR BIREFRINGENCE

A simple apparatus for measuring linear birefringence is shown in Figure 3.2. The vertical optical bench setup is particularly convenient since the sample may simply lie on a horizontal surface, rather than be supported if a horizontal optical bench were used.

A rotation stage may be needed in order to position the sample for maximum birefringence signal and to determine the orientation of the axis. The center of the rotation stage must coincide with the optical axis of the system.

If a laser is used as the light source, care must be taken to avoid modulated interference effects caused by reflections from the optical element surface. Anti-reflective coatings will minimize this effect on Series I (rectangular)

modulators. Series II (octagonal) will not exhibit the effect if carefully positioned.

Also, watch for residual birefringence in any windows or sample containers.

Calibrate using a retarder plate with known retardation of 1/30 wave or less.

Good sample source: A strip of cellophane tape on a microscope slide.

The slow axis is along the length of the tape.

$$B_{\text{sample}} = B_{\text{standard}} \left(\frac{V_{1,\text{sample}}}{V_{1,\text{standard}}} \right)$$

B = retardation in convenient units

Figure 3.2. Linear Birefringence Setup.

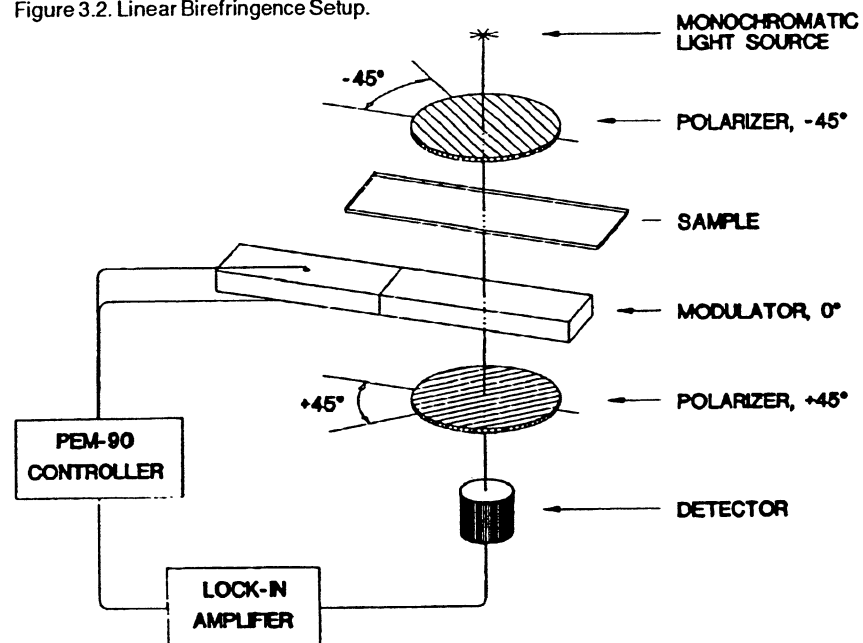

C. OPTICAL ROTATION

Optical rotation (or circular birefringence) describes rotation of the plane of polarization of plane polarized light. Optical rotation is observed with solutions of sugar and other chiral molecules, with the Faraday effect, etc.

A quarter-wave plate is inserted between the initial polaroid and the modulator. The plate is oriented with its fast axis rotated 45 degrees (around the light axis) from the polarizer passing axis, such that the waveplate and polaroid act as a circular polarizer.

The circularly polarized light is converted by the PEM to light which switches between linearly polarized states, at the modulator frequency, alternatively polarized along +45 degrees and -45 degrees relative to the transverse PEM axis.

This light transverses the sample, then a second polarizer with its passing axis oriented *parallel* to the PEM axis. With no sample or no optical rotation, no signal at the modulator frequency is generated.

A finite optical signal produces an output signal which is proportional to the rotation angle if the latter is small.

Good sample source: Karo syrup.

Figure 3.3. Measurement of Optical Rotation.

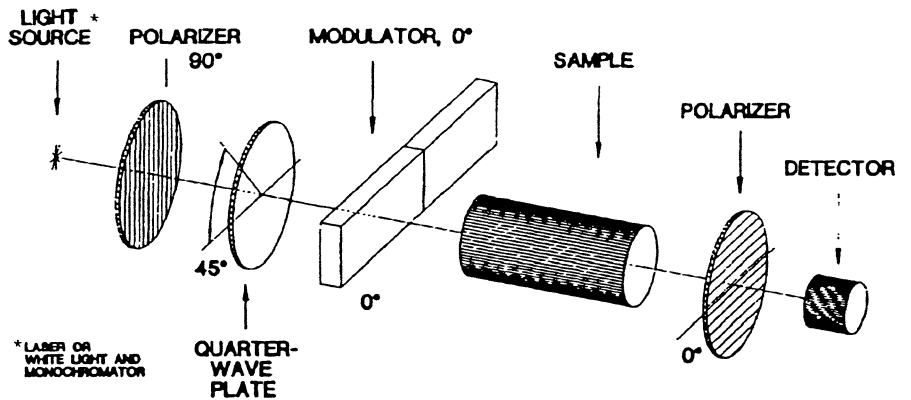

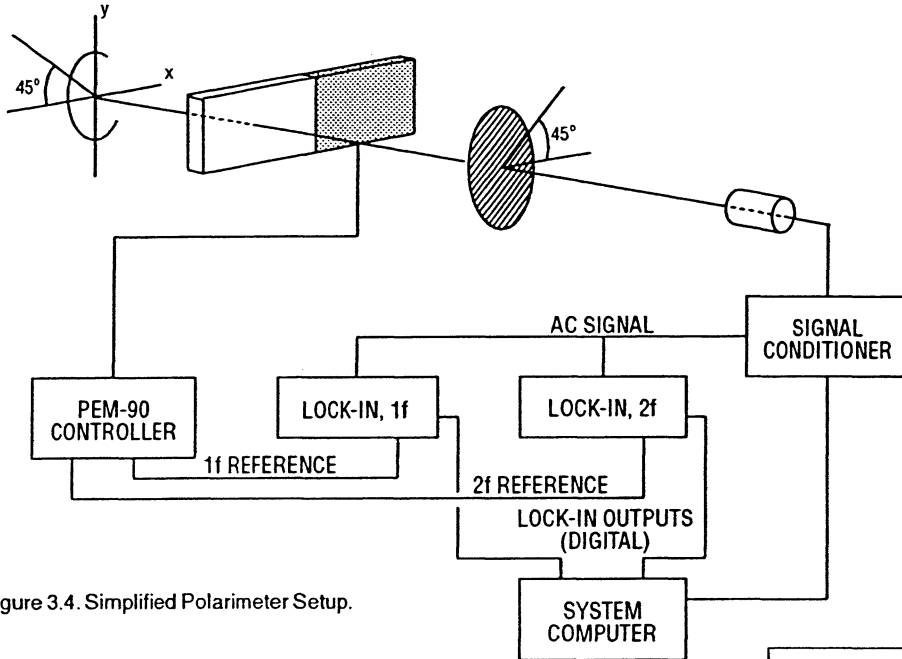

Figure 3.4. Simplified Polarimeter Setup.

D. STOKES POLARIMETRY

This is useful if the linear component direction is known. For an arbitrary linear polarization angle, two measurements at 45 degrees with respect to each other must be made with the modulator/polarizer system.

Rotate the entire polarimeter apparatus through 45 degrees. The light source must be steady and not change in intensity.

Using two modulators, you receive data in "real" time. The polarizer is mounted at 22.5 degrees. The modulator must operate at different frequencies; typically a frequency difference of 2 to 5 Hz is used. Stokes Parameters are given below in Table 3.1.

Figure 3.5. Dual Modulator Polarimeter Setup.

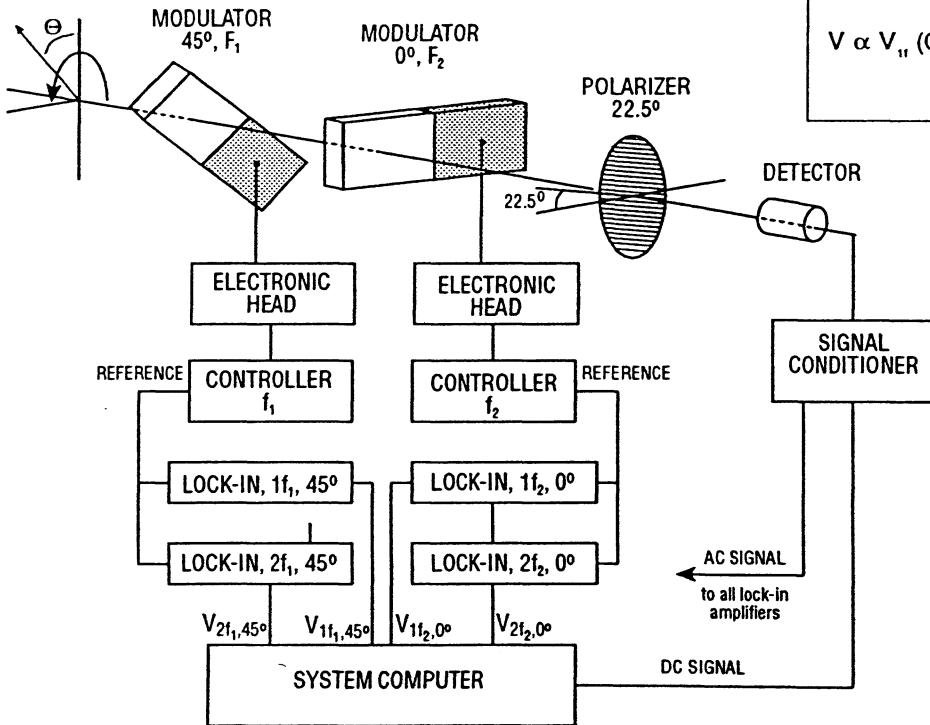

Fractional polarizations:	
$Q \propto V_{21}(0^\circ)$	$\left \begin{matrix} \text{linear} \\ \text{polarization} \end{matrix} \right = \frac{\sqrt{Q^2 + U^2}}{I}$
$U \propto V_{21}(45^\circ)$	$\Theta = \frac{1}{2} \tan^{-1}\left(\frac{U}{Q}\right)$
$V \propto V_{11}(0^\circ) = V_{11}(45^\circ)$	$\left \begin{matrix} \text{circular} \\ \text{polarization} \end{matrix} \right = \frac{V}{I}$

Table 3.1. Stokes Parameters with Rotating Polarimeter, Dual Modulator Polarimeter

4. CALIBRATION & MAINTENANCE

A. CALIBRATION

PEM-90 modulators are calibrated at the factory before shipment. For most applications recalibration is neither necessary nor appropriate. For a few applications, however, *in situ* calibration procedure will be necessary if optimum performance is to be achieved. Hinds engineers will be glad to advise users on whether *in situ* calibration is appropriate in a particular case.

The Calibration appendix contains an extensive discussion of the theory of retardation calibration and a variety of methods for establishing known calibration points. Fortunately, photoelastic modulators are to a large extent self-calibrating, and most of the equipment needed for calibration will be required for the user's experiment.

Adjustment of Peak Retardation Calibration

The most common reference point used for calibration is half-wave peak retardation or an integral multiple of half-wave. This condition may be easily observed using an oscilloscope, as described in the Calibration appendix. Even when other reference points are used, this method should be regarded as the "coarse adjustment" on the modulator calibration.

The peak retardation calibration of the modulator is adjusted by R4, a multi-turn trimpot labeled "Range" in the electronic head. With the appropriate optical bench setup and detection system the trimpot is adjusted until the calibration condition is obtained. For example, in the case of half-wave calibration, the appropriate flat topped (or flat bottomed) characteristic waveform is observed on the oscilloscope.

B. MAINTENANCE

The optical head contains an optical element and requires the same care in use as other components such as lenses and mirrors. The unit should not be operated in a dusty, corrosive, or otherwise contaminating environment. Small amounts of dust may be removed from the optical element with a soft brush such as an artist's camel-hair brush. If more serious contamination occurs, consult Hinds engineers.

The PEM units are rugged and reliable, and normally require no additional maintenance. If trouble occurs, please consult the troubleshooting section and then contact Hinds engineers for assistance.

5. TROUBLESHOOTING

The purpose of this section is to determine whether the user's problem is caused by the PEM, or whether the problem exists elsewhere in the system. It is also intended to facilitate communication with the factory about the nature of the problem.

A. RETARDATION/WAVELENGTH RETARDATION ENVELOPE

PEMs are restricted in the amount of peak retardation which they can provide. For example, the system is not capable of giving directly a peak retardation which exceeds 1.0 wave. The value of retardation times wavelength also must not exceed a certain limit. For Model I/FS50 this limit is 500 nanometers x waves. These relationships are shown in Figure 5.1 for the Model I/FS50 PEM.

Figure 5.1. Maximum Retardation (wave) vs Wavelength (nm) Model I/FS50.

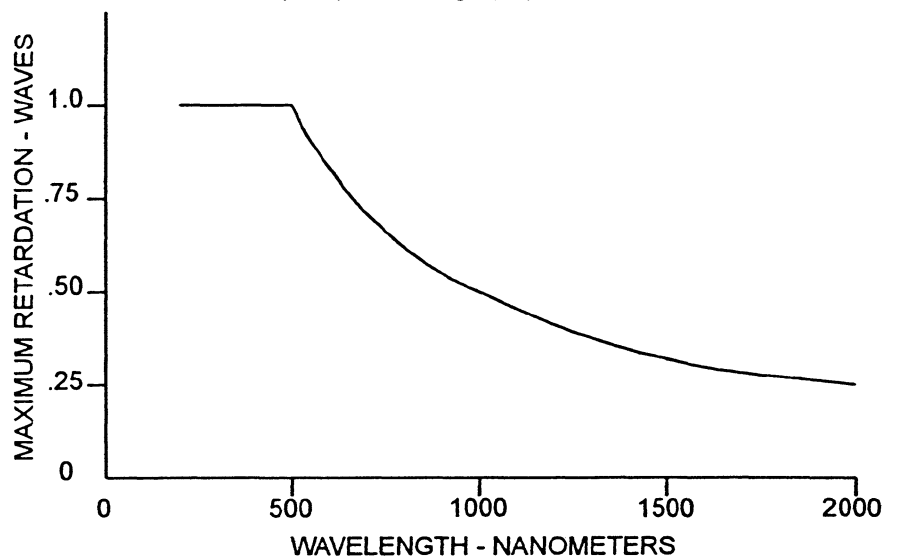

For Series I modulators (e.g. Model I/FS50) the product of peak retardation (in waves) and wavelength (in nanometers) cannot exceed 500. It is possible under certain circumstances to set the controller to yield a higher value, but the actual peak retardation provided by the modulator will be limited as above. If this condition exists, it will not be possible to increase the wavelength display using the front panel up-arrow key, although it will be possible to decrease it.

B. RESETTING THE CONTROLLER TO DEFAULT PARAMETERS

The controller is designed to "remember" the wavelength and retardation settings which were present when "set" using the SET button. It is sometimes desirable to return the controller to the factory default parameters which are retardation of 0.000 waves and wavelength of 632.8 nanometers.

To reset the controller to the factory default values, use the following procedure:

1. The controller should be turned OFF.
2. While holding the UP-arrow key in, turn the power switch to the ON position.
3. Release the UP-arrow key.

The front panel should light, the retardation display should read zero, the modulator frequency should be displayed in the right-hand display and the LOC mode status light should be lit. Selecting wavelength in nanometer units should result in 632.8 being displayed on the right-hand display.

C. REFERENCE SIGNAL TEST

An excellent check for correct modulator operation may be performed by examining the f reference signal waveform with an oscilloscope. The peak-to-peak square wave voltage should be 5 volts and the frequency should correspond to the modulator frequency. If a stable square-wave reference signal is observed, this is a very good indication that the modulator is working correctly.

Reasons that an unstable reference signal might be observed include:

1. Retardation and/or wavelength settings are too low. Try setting retardation at quarter-wave and wavelength at 632.8.
2. Retardation and/or wavelength settings are too high. To check this observe the center of the inside of the controller cabinet, either through the holes in the top cover or by removing the top cover. If a red LED is observed, either steady or flashing, the modulator is operating in the LIMIT condition and the retardation and/or wavelength should be reduced.

D. OPTICAL TEST

A final test of the modulator operation is the optical test that is described in the section Setup & Checkout at the front of the manual. Be sure that the polarizers are properly oriented, at approximately 45 degrees for most modulator optical heads, or vertically and horizontally for the zinc selenide modulator heads.

A HeNe laser (or other monochromatic light source) and a suitable detector may be used with the above setup for further diagnostics of the modulator. For a setting of quarter-wave and the appropriate wavelength, the oscilloscope waveform (with DC coupling) should appear as follows:

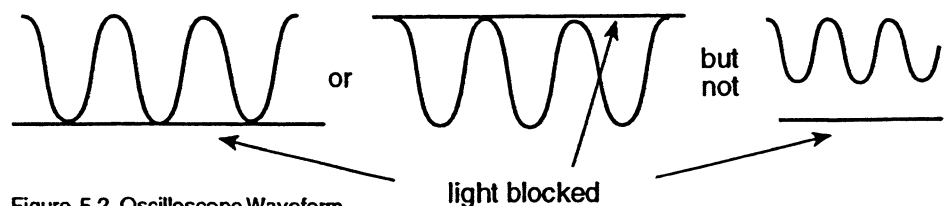

Figure 5.2. Oscilloscope Waveform.

If the signal with the light blocked does not coincide with either the peaks or the valleys of the observed waveform, the bandwidth of the detector and its associated circuitry is insufficient.

If the modulator system passes all of the above tests, the user may have confidence that the problems with his system are not with the modulator. Whether the modulator passes the tests or not, the user should contact Hinds Instruments or the dealer for further assistance in troubleshooting.

6. THEORY OF OPERATION

The PEM-90 photoelastic modulator is an instrument used for modulating or varying (at a fixed frequency) the polarization of a beam of light. Hinds photoelastic modulators are used for measurement of circular and linear dichroism, birefringence, optical rotation, and for ellipsometry, polarimetry, reflection difference spectroscopy, and FTIR double modulation.

The PEM-90 principle of operation is based on the photoelastic effect, in which a mechanically stressed sample exhibits birefringence proportional to the resulting strain. Photoelastic modulators are resonant devices, each producing oscillating birefringence at a fixed frequency in the low frequency ultrasound range (20 kHz to 100 kHz). These factors result in a number of very useful advantages which are unique to the PEM including wide acceptance angle, large aperture, and high modulation "purity."

In its simplest form the PEM-90 consists of a rectangular bar of a suitable transparent material (fused silica, for example) attached to a piezoelectric transducer (Figure 6.1.b). The bar vibrates along its long dimension (Figure 6.1.a) at a frequency determined by the length of the bar and the speed of a longitudinal sound wave in the optical element material. The transducer is tuned to the same frequency and is driven by an electronic circuit which controls the amplitude of vibration. The oscillating birefringence effect is at its maximum at the center of the fused silica bar.

By carefully varying the type, size, and shape of optical material, and coupling closely matched drive and control circuits to the PEM-90 optics, we have developed a range of photoelastic modulators for a variety of applications. In addition to the information provided in this manual, Hinds engineers are available to help with your specific application setup.

Figure 6.1.a. Vibrational Motions.

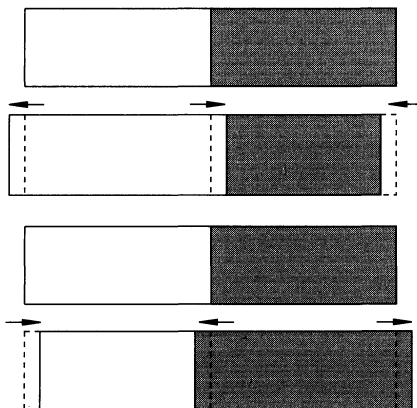
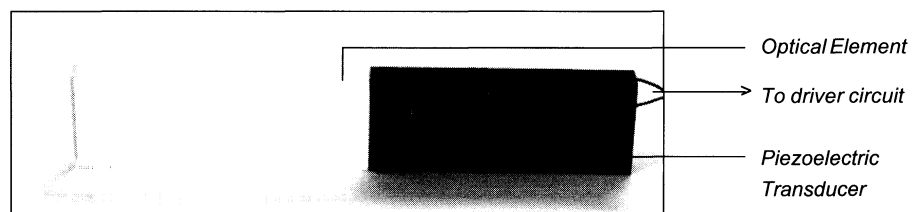

Figure 6.1.b. Modulator Optical Assembly for Model I/FS50.



A. PRINCIPLES OF OPERATION

The phenomenon of photoelasticity is the basis for operation of the PEM-90. If a sample of transparent solid material is stressed by compression or stretching, the material becomes birefringent, that is, different linear polarizations of light have slightly different speeds of light when passing through the material.

PEM-90 Series I modulators use a rectangular shape for the modulator optical element. In the Model I/FS50, a fused silica bar is made to vibrate with a natural resonant frequency of about 50 kHz. This vibration is sustained by a quartz piezoelectric transducer attached to the end of the bar, as shown in Figure 6.1.

Figure 6.3. Quarter-Wave Retardation.

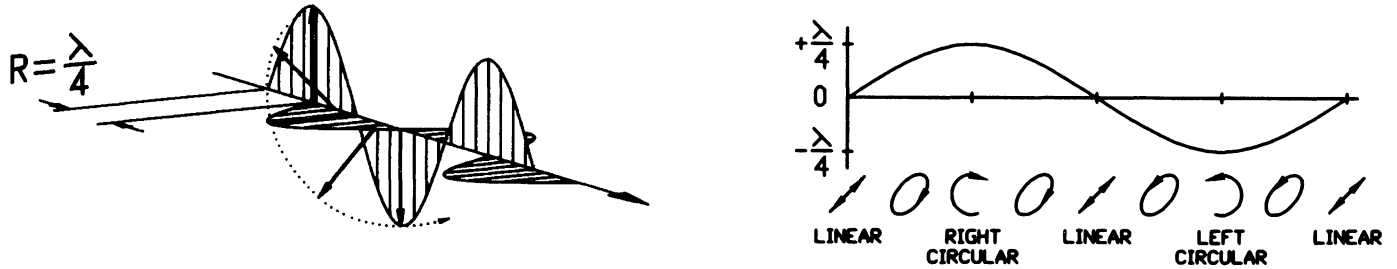

Half-Wave Retardation

Another important condition occurs when the peak retardation reaches one-half of the wavelength of the light (Figure 6.4.left). When this happens, the PEM acts as a half-wave plate at the instant of maximum retardation and rotates the plane of polarization by 90 degrees.

Figure 6.4.right shows retardation vs. time for a modulator cycle and indicates polarization states at several different times during a cycle. At maximum retardation, the polarization states are linear, rotated by 90 degrees.

The half-wave retardation condition is particularly important for calibration of the PEM-90.

Figure 6.4. Half-Wave Retardation.

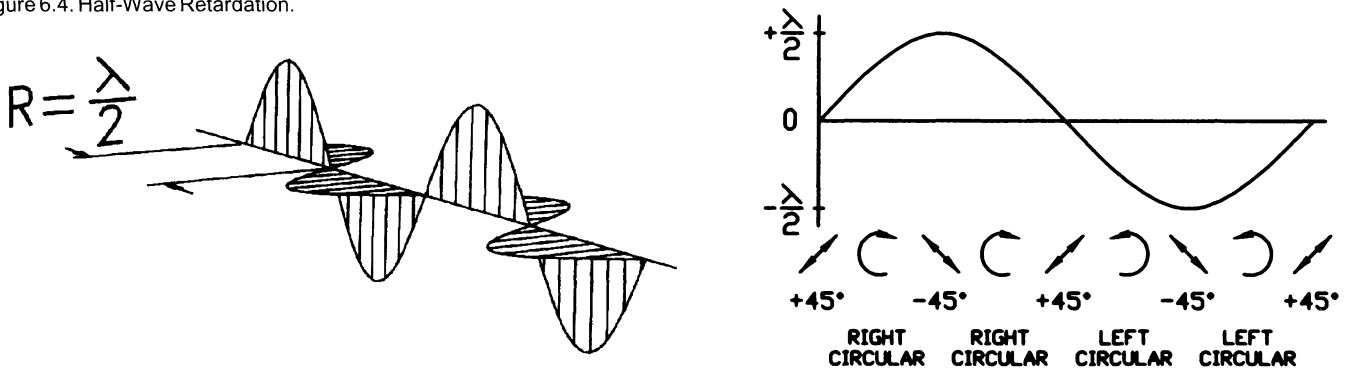

Symmetric Optical Element

PEM-90 Series II modulators use a patented symmetric or "octagonal" shape for the modulator optical element (Figure 6.5). This utilizes a "two-dimensional" standing wave which approximately doubles the retardation available with a given drive voltage. Series II modulators are particularly useful in the infrared spectrum.

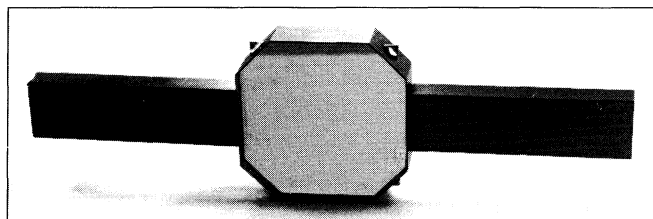

Figure 6.5. Symmetric Optical Assembly for Model II/ZS37.

7. USER SUPPORT INFORMATION

Hinds Instruments makes every attempt to ensure that the instruments we provide are products of superior quality and workmanship. We also aim to provide superior technical user support. If you have any questions, or if you encounter problems in the operation of your PEM instrument or system, please contact us. Our customer service staff is available to assist you from 8:00AM to 4:00PM, Pacific Standard Time, Monday through Friday. The telephone number is (503) 690-2000 or toll free, in the United States, (800) 688-4463.

A. LIMITED WARRANTY

Hinds Instruments, Inc. warrants the PEM-90 photoelastic modulator and systems to be free from defects in materials and/or workmanship when operated in accordance with the manufacturer's operating instructions for one (1) year from the date of purchase, subject to the provisions contained herein. Our warranty shall extend to the original purchaser only and shall be limited to factory repair or replacement of defective parts.

Exclusions

This warranty does not cover normal maintenance, damage resulting from improper use or repair, or abuse by the user. This warranty extends only to repair or replacement, and shall in no event extend to consequential damages. In the event of user repair or replacement, this warranty shall cover neither the advisability of the repair undertaken, nor the sufficiency of the repair itself.

THIS DOCUMENT REFLECTS THE ENTIRE AND EXCLUSIVE UNDERSTANDING OF THE PARTIES, AND EXCEPT AS OTHERWISE PROVIDED HEREIN, ALL OTHER WARRANTIES, EXPRESS OR IMPLIED, PARTICULARLY THE WARRANTIES OF MERCHANTABILITY AND/OR FITNESS FOR A PARTICULAR PURPOSE, ARE EXCLUDED.

This warranty gives you specific legal rights, and you may also have other rights that vary from state to state.

B. RETURN FOR REPAIR PROCEDURE

If your unit ever does need repair, please contact us before attempting repairs yourself or returning it to us. We may be able to provide additional troubleshooting suggestions to help diagnose the problem. In the event it is necessary to return the unit to us, we will give it our prompt and professional attention. In most cases, we can repair and return your instrument to you faster than you could diagnose and repair it yourself.

To arrange for service: In the event of defects or damage to your unit, first contact us or telephone us at (503) 690-2000 or toll free, in the United States, (800) 688-4463. Give us a brief description of the problem. We will then advise

whether factory repair is indicated, and what needs to be returned. If factory service is required, we will give you a Return Material Authorization (RMA) number. You should return your instrument as follows:

Packing

Special care must be used to pack the optical head. We can give you instructions for packing the optical head. If the original shipping carton and packing materials for the optical head are still available, they should be used.

Consider the following guidelines when preparing the instrument for return:

- Wrap each unit in a plastic bag
- Pack in the original shipping carton or a sturdy oversized carton
- Use plenty of packing materials
- Return all cables except the power cable for the controller

Items to include

- The RMA number
- All cables except the power cable for the controller
- A brief description of the problem with all known symptoms
- Information on how to contact you
- Your return shipping address (UPS will not deliver to a post office box)

Shipping arrangements

- Send freight prepaid (UPS recommended)
- Insurance is recommended (we can advise you the current replacement value of the item being shipped)
- Sorry, we are unable to accept COD shipments

Return Shipping Address

Customer Service
Hinds Instruments, Inc.
3175 N.W. Aloclek Dr.
Hillsboro, OR 97124-7135
U.S.A.

If your unit is under warranty, after repair or replacement has been completed, we will pay the shipping costs to return the instrument to you via a carrier we choose to any destination within the continental United States. If you desire some other specific form of conveyance, or if you are located outside the continental United States, then you must bear the additional cost of return shipment.

If your unit is not under warranty, we will contact you with an estimate of the charges. If you approve of the indicated repairs and cost, then we will return your repaired unit after all charges (including parts, labor and return shipping and handling) have been paid. If you do not approve of our proceeding with the repair, then your unit will be returned as is via UPS COD for the amount of the UPS COD freight charges.

8. BIBLIOGRAPHY

1. J.C Kemp, "Piezo-optical birefringence modulators: New use for a long-known effect," *J. Opt. Sci. Amer.*, **59**, 8 pp. 950-954, Aug. 1969.
2. J.C. Kemp, "Polarized light and its interactions with Modulating Devices," Hillsboro OR: Hinds Instruments, Inc. 1987.
3. J.C. Kemp, and M.S. Barbour, "A Photoelastic Modulator Polarimeter at Pine Mountain Observatory," *Publications of the Astronomical Society of the Pacific*, **93** pp. 521-525, August, 1981.
4. K.W. Hipps and G.A. Crosby, "Applications of the Photoelastic Modulator to Polarization Spectroscopy," *J. Phys. Chem.*, **83**, pp. 555-562, 1979.
5. A.F. Drake, "Polarization modulation - the measurement of linear and circular dichroism," *J. Phys. E: Sci. Instrum.*, **19**, pp. 170-181, 1986.
6. S.N. Jaspersen and S.E. Schnatterly, "An Improved Method for High Reflectivity Ellipsometry Based on a new Polarization Modulation Technique," *Rev. Sci. Inst.*, **40**, No. 6, June 1969.
7. G.E. Jellison, Jr., and F.A. Modine, "Accurate Calibration of a Photoelastic Modulator in a Polarization Modulation Ellipsometry Experiment," *Pro. Soc. PhotoOpt. Instrum. Eng.*, **1166**, 231-241, 1990.
8. R.W. Collins and Y-T. Kim, "Ellipsometry for Thin Film and Surface Analysis," *Anal. Chem.*, **62**, 17. pp. 887A-900A, Sept., 1990.
9. R.M.A. Azzam and N.M. Bashara, "Ellipsometry and Polarized Light," pp. 260—262, 415-416, North Holland, Elsevier Science Publishers, V.V., 1989.
10. L.A. Nafie and T.B. Freedman, "Vibrational Circular Dichroism Spectroscopy," *Spectroscopy*, **2**, 12, pp. 24-29, Dec. 1987.
11. L. A. Nafie, "Polarization Modulation FTIR Spectroscopy," *Advances in Applied Fourier Transform Infrared Spectroscopy*, pp. 67-104, M.W. Mackenzie, ed., Wiley, 1988.
12. D.E. Aspnes, J.P. Harbison, A.A. Studna, and L.T. Florez, "Reflectance-difference spectroscopy system for real-time measurements of crystal growth," *Appl. Phys. Lett.*, **52**, 12, pp. 957-959 March, 1988.
13. I. Noda, A.E. Dowrey, and C. Marcott, "A Spectrometer for Measuring Time-Resolved Infrared Linear Dichroism Induced by a Small-Amplitude Oscillatory Strain," *Applied Spectroscopy*, **42**, 2, p. 203-216, 1988.

14. G.R. Boyer, B.F. Lamouroux, and B.S. Prade, "Automatic measurement of the Stokes vector of light," *Applied Optics*, **18**, 8, pp. 1217-1219, 15 April 1979.
15. P.A. Snyder, "Status of Natural and Magnetic Circular Dichroism Instrumentation Using Synchrotron Radiation," *Nuclear Instruments and Methods in Physics Research*, **222**, pp. 364-371, 1984.
16. D. Wroblewski, K.L. Huang, and H.W. Moos, "Scanning polarimeter for measurement of the poloidal magnetic field in a tokamak," *Rev. Sci. Instrum.*, **59**, 11, pp. 2341-2350, November, 1988.

APPLICATIONS

REFERENCE

General	1, 2, 4
Polarimetry	2, 3, 14, 16
Ellipsometry	6, 7, 8, 9
Circular Dichroism	4, 5, 10, 11, 15
Linear Dichroism	4, 5, 13
FTIR Double Modulation	10, 11
Reflection Difference Spectroscopy	12

9. SPECIFICATIONS

All parameters are measured at 25 degrees Celsius, driving an I/FS50 modulator head set at .500 waves and 632.8 nM, unless otherwise specified.

PERFORMANCE CHARACTERISTICS

CHARACTERISTIC	SPECIFICATION	REMARK
FREQUENCY		
Operating Frequency.....	20 kHz to 100 kHz.....	Fixed Frequency, Fundamental (f)
Display Range		
f.....	20 kHz to 100 kHz	
2f.....	40 kHz to 200 kHz	
Display Resolution		
f.....	1 Hz	
2f.....	2 Hz	
Display Accuracy		
f.....	±3 Hz	
2f.....	±6 Hz	
Reference Stability		
f.....	± 0.8 μS.....	Referenced to zero crossing
Phase Stability Duty-Cycle		
f.....	50% ± nominal.....	Factory adjustable
2f.....	50% ± nominal.....	User adjustable from 10 to 90%
RETARDATION AMPLITUDE		
Electronics Stability.....	0.05 %.....	After 30 minutes stabilization
Settability.....	0.5 %, ± 2.5 nm	
Resolution.....	1/4096 of full scale	
Minimum Level.....	Varies.....	That level required to maintain the head oscillator in oscillation
WAVENUMBER		
Display.....	1 to 999,999	
Accuracy.....	± 1 wn, ± 1 lsb	
Resolution.....	1 wavenumber	

**CONTROLLER
ELECTRONIC
HARDWARE**

CHARACTERISTIC	SPECIFICATION	REMARK
MICROCONTROLLER.....	80C31BH	
Xtal.....	12 MHz	
ROM	27C256	
Size	32 k x 8	
RAM Internal	(80C31BH)	
Size	128 k x 8	
EEPROM.....	93C46	
Size	128 x 8 (64 x 16)	
I/O External	82C55	
Ports	3 - 8 bit	
 A/D CONVERTER	 LT1290CCJ	
Resolution	12 bits	
Full Scale Input.....	0 to 5.00 volts	
Number of Channels	8	
Retardation	Channel 1	
Aux 1	Channel 2	
Aux 2	Channel 3	Available through
Aux 3	Channel 4	remote connector
Total Adjusted Error	± 1 LSB (least significant bit)	
Bus Interface.....	SPI (microwire).....	4 - wire synchronous
Conversion Time	100 uSEC	
 D/A CONVERTER	 MAX508	
Resolution	12 bits	
Full Scale Output.....	0 to 5 volts	
Reference.....	Buried 5.00 V Zener....	Drives A/D reference
Linearity Error	± 1 LSB	
 RS232C INTERFACE	 (80C31BH).....	 Microcontroller serial channel
Baud Rates	9600	
Data Bits.....	8	
Stop Bits	1	
Parity	None	

CONTROLLER:

ENVIRONMENTAL CHARACTERISTICS

CHARACTERISTIC	SPECIFICATION	REMARK
TEMPERATURE		
Non-Operating	-40° C to +65° C (-40° F to 150° F)	
Operating.....	0° C to +50° C (32° F to 122° F)	
HUMIDITY.....	0 to 95 % RH	Non-Condensing

PHYSICAL CHARACTERISTICS

CHARACTERISTIC	SPECIFICATION	REMARK
Shipping Weight	5.5 kg (12 lbs).....	Modulator Head Assembly not included
Height	89 mm (3.5 inches)	
Width	203 mm (8.0 inches)	
Depth	305 mm (12.0 inches)	

ELECTRICAL CHARACTERISTICS

CHARACTERISTIC	SPECIFICATION	REMARK
Power Supply	115/230 VAC	Universal 50/60 Hz
Power Consumption	60 VA	Maximum

APPENDICES

A. CALIBRATION	III
B. MODULATED INTERFERENCE EFFECTS WITH LASERS	XI
C. LINEAR BIREFRINGENCE AND OPTICAL ROTATION	XV
D. LINEAR & CIRCULAR DICHROISM	XXI
E. STOKES POLARIMETRY	XXV

CALIBRATION

by Dr. Theodore Oakberg

Proper retardation calibration of photoelastic modulator systems is essential for optimum performance. This is best accomplished with the modulator in the optical setup in which it will be used. This application note is intended to assist users with *in situ* calibration of their PEMs.

Some calibration techniques are very simple. In the vacuum UV with a circular dichroism experiment, the modulator retardation might simply be adjusted to give a maximum signal when a known CD spectrum line is being observed. Even this simple technique could be improved with the Bessel function methods described at the end of this application note.

CALIBRATION THEORY

The optical setup for most calibration procedures is shown in Figure 1. The modulator is placed between crossed polarizers, each of which is oriented with its passing axis at 45 degrees with respect to

the modulator axis. For some calibration procedures a retarder is required. If so, it should be placed between one polarizer and the modulator, with the fast axis parallel or perpendicular to the modulator axis.

The space between the two polarizers should contain nothing but the modulator and the waveplate (if needed). Mirrors, prisms, filters, windows, lenses, monochromators or other wavelength selecting devices should be located outside the polarizers, if possible.

Kemp¹ has derived the equations for the intensity of the light reaching the detector, as a function of time. A_0 is the amplitude of the sinusoidal retardation function; B is the retardation magnitude of the waveplate; and Ω is the angular frequency of the modulator. The general expression for the intensity function is:

$$I = 1/2 \{1 - \cos B \cos(A_0 \cos \Omega t) + \sin B \sin(A_0 \cos \Omega t)\} \quad (1)$$

Figure 1.

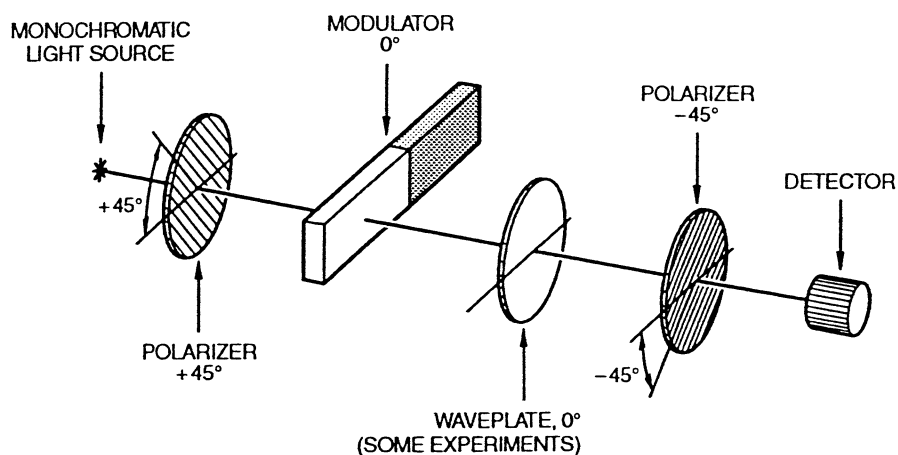

For the majority of applications, expansion of this expression using a Fourier Series is very useful:

$$\begin{aligned}
 (2) \quad I &= 1/2\{1-\cos(B)J_0(A_0) \quad \text{DC} \\
 &+ 2\sin(B)J_1(A_0)\cos(\Omega t) \quad \text{1f} \\
 &+ 2\cos(B)J_2(A_0)\cos(2\Omega t) \quad \text{2f} \\
 &+ \dots \text{higher terms} \}
 \end{aligned}$$

The latter expression shows the DC component of the expression and the first and second harmonics of the optical intensity signals. Using the reference signals from the modulator controller, these harmonics can be easily detected with a lock-in amplifier.

If there is no birefringence present, the above equations reduce to the following. Note that there is no fundamental (first harmonic) component in the intensity signal.

$$(3) \quad I = 1/2 \{1-\cos(A_0\cos\Omega t)\}$$

and

$$(4) \quad I = 1/2 \{1-J_0(A_0)+2J_2(A_0)\cos(2\Omega t) + \text{higher terms} \dots \}$$

These four equations are the basis for the calibration procedures described in the remainder of this application note.

LIGHT SOURCES FOR MODULATOR CALIBRATION

The procedures described below for PEM calibration each require a monochromatic light source. A brief discussion of light sources suitable for this purpose is in order.

Lasers are excellent sources of monochromatic light. At Hinds, we use HeNe lasers to calibrate most PEMs which we manufacture. Laser beams are intense and well collimated, and do not normally require

any focussing optics in the calibration optical setup.

Interference effects may be present when using a laser, especially with Series I modulators. These effects usually do not seriously hamper calibration, except for those techniques which involve detection at the modulator frequency 1f. In those cases, care must be used to eliminate the interference effects before performing the calibration.

Spectral light sources, such as mercury lamps, are also excellent light sources when used with a monochromator or selected interference filters which match the spectral lines. These allow calibration of the PEM over a range of wavelengths. Interference effects should be negligible. Systems based on interference filters may offer significantly better light throughput than monochromator systems.

White light sources may also be used with monochromators, but here some caution is advised. The error in accuracy of the wavelength of the light should be recognized as approximately the optical bandwidth of the monochromator.

Within the bandwidth of a spectrum line, the system sensitivity will be strongly affected by slope of the spectral radiance of the light and by the spectral sensitivity of the detector. The situation also applies to using interference filters, but the "effective modulation wavelength" may be even further from the nominal center bandwidth of the filter.

For the near IR, visible and near UV, the hottest light source available should be used. If an incandescent lamp is used, it should be of the halogen variety. High pressure Xenon lamps, carbon arc lamps and the like would be even better.

Figure 2. Block Diagram for Oscilloscope Calibration Method.

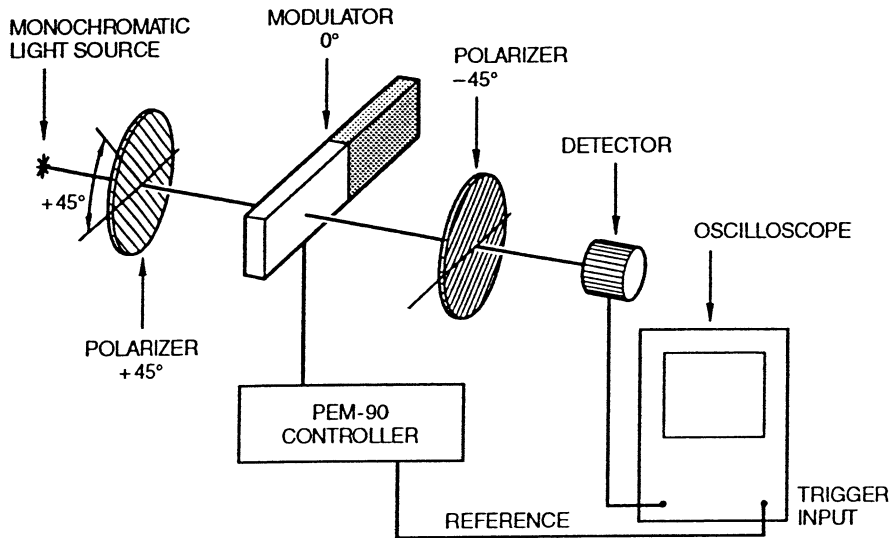

As a general rule, the light source being used in a particular experiment may be the best one to use for the calibration.

CALIBRATION USING AN OSCILLOSCOPE

The most straightforward procedure, and the one used at Hinds for the factory calibration of modulators, utilizes a monochromatic light source (e.g. HeNe laser), a solid state detector (e.g. silicon photodiode), and an oscilloscope. A block diagram for the setup is given in Figure 2.

The detector and its associated electronics (including the oscilloscope) should have a frequency

bandwidth several times the frequency of the modulator. Calibration can be done in many cases when this condition is not met, but the waveforms will be distorted and the proper half-wave condition will be more difficult to identify.

Referring to equation 3, interesting and distinctive waveforms on the oscilloscope occur whenever A_0 is an integral multiple of $\lambda/2$ waves or π radians. For half-wave peak retardation, the intensity waveform is shown in Figure 3.

Note the flat top of the peaks. (Depending on the precise optical and electronic configurations, this display might appear inverted.) This feature is very distinctive, and by adjusting the retardation it is possible to fix the retardation at half-wave to an accuracy of better than 1%. Figures 4 and 5 show waveforms for retardations slightly less and slightly more than half-wave.

Figure 3. Waveform for Half-wave Retardation.

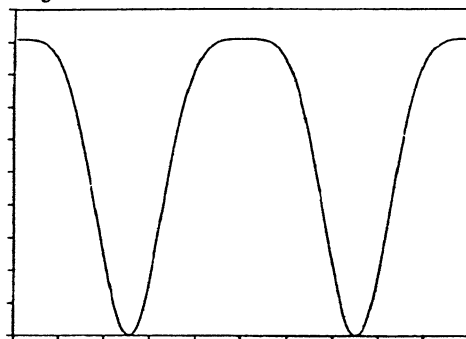

Figure 4. Retardation 90% of Half-wave.

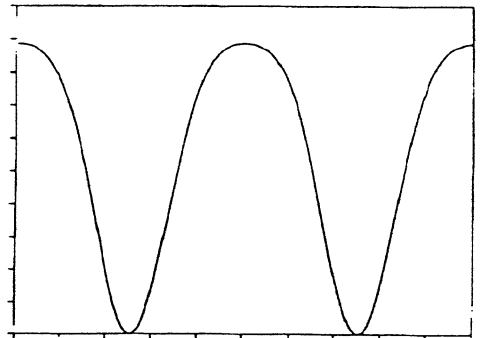

Figure 5. Retardation 110% of Half-wave.

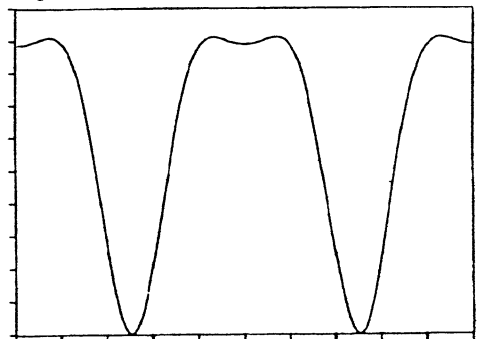
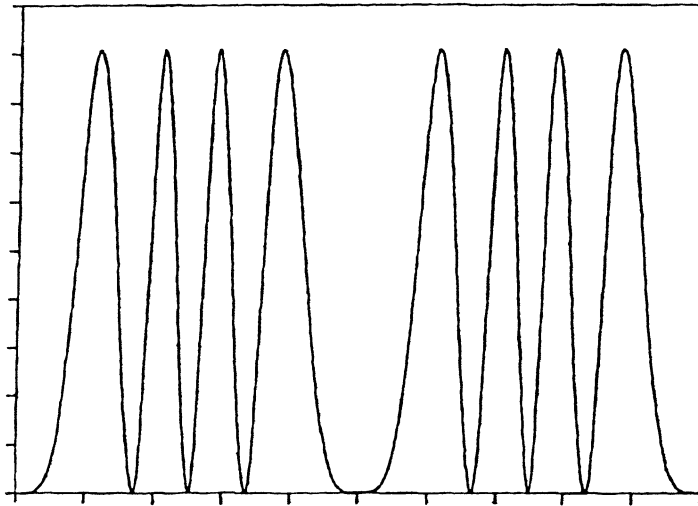

Figure 6. Waveform for a Retardation of Four Half-waves.



Precise adjustment of the modulator to give the required flat-topped waveform is accomplished by adjusting the range resistor on the electronic head driver board. Details of the procedure are given in the User Manual.

For retardation values of multiple half-waves, the intensity functions continue to exhibit the "flat-topped" (or "flat bottomed") characteristic which is useful for calibration.

The waveform for a retardation of four half-waves is shown in Figure 6.

This technique is used at Hinds to calibrate infrared PEMs such as

the zinc selenide modulator. If the stress-induced retardation, expressed in units of length, is really independent of wavelength, then this may be used to extrapolate infrared calibration from visible light measurement. For example, setting the modulator to give four half-waves of retardation at 0.5 microns would give one half-wave of retardation at 2.0 microns. Experiments with infrared modulators indicate that this relationship holds well in the infrared. It is prudent, however, for the investigator to verify the calibration in his own optical setup.

MULTIPLE REFLECTION TECHNIQUES

Precise setting of the modulator peak retardation at levels less than half wave may be done by several different methods. For integral fractions of a half-wave, the oscilloscope technique described above may be used by arranging the optical system so that the light beam traverses the center of the modulator multiple times. For example, by traversing the modulator optical element twice, a flat-topped waveform (half-wave retardation) would indicate quarter-wave retardation (for a single pass). See Figure 7.

Figure 7. Setup for Double Pass Modulation.

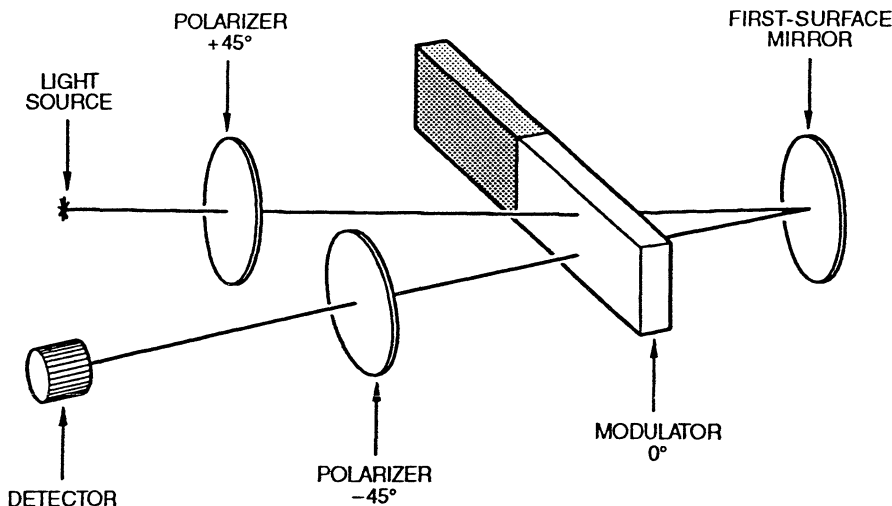

STATIC WAVEPLATE TECHNIQUES

Another technique for establishing a fractional retardation would be to use a static waveplate with known retardation. The waveplate would be placed as shown in Figure 1, with the fast axis of the waveplate parallel to the modulator axis. If the sum of the static waveplate retardation and the modulator peak retardation is one half-wave, then a flat-topped oscilloscope waveform will result. The modulator retardation would then be half-wave minus the retardation of the fixed waveplate.

The use of a calibrated Soleil-Babinet Compensator would give a means of calibrating a modulator for continuous values of peak retardation.

BESSEL FUNCTION ZERO METHODS

An examination of equation 2 suggests a method for precise setting of certain values of retardation.

Note, for example, the "DC" term in equation 2. For certain values of A_0 (e.g. 2.405 radians), $J_0(A_0) = 0$, and therefore the DC term becomes a constant, independent of the birefringence B. The DC intensity also becomes independent of many other changes which could be made to the optical system, such as the angular position of the second polarizer. The DC intensity can therefore be used for "normalization" of the AC signals, by forming the ratio V_{AC}/V_{DC} . This is now independent of fluctuations in intensity in the light source, changes in optical transmission, etc.

To establish precisely the controller setting for which $J_0 = 0$, graphs of V_{DC} vs controller setting for several different angular positions of the second polarizer. A typical set of graphs is shown in Figure 8. Notice that the graphs intersect at one particular controller setting. This fixes the controller setting for which the Bessel function J_0 vanishes.

If a lock-in amplifier is available, and if the modulator is capable of

providing adequate peak retardation, then the AC signals can provide similar retardation calibration points. Consider the second harmonic signal, at twice the modulator frequency. At a peak retardation or amplitude of $A_0 = 5.136$ radians, $J_2(A_0) = 0$. This setting can be established with great accuracy using a lock-in at frequency $2f$.

Addition of a birefringent element as shown in Figure 1, so that a significant signal at the modulator frequency is obtained, will enable determining the controller setting for which $J_1(A_0) = 0$. (This occurs for $A_0 = 3.872$ radians.) Detection of the null point is made with a lock-in amplifier at the modulator frequency.

BESSEL FUNCTION RATIO METHODS

Most of the calibration methods described above are used to establish specific retardation levels with precision. There is a need to extend the calibration to other retardation settings. Using a lock-in amplifier, these extensions may be accomplished using the ratios of Bessel functions. The method described here assumes the use of a stable light source and optical setup. The example given uses the half-wave condition, but the technique can be easily modified to use a Bessel Function Zero starting point.

Consider Figure 2 and the $2f$ term of equation 4. The signal voltages V_{2f} for two different retardation levels are proportional to the Bessel functions of those retardations, as shown in equation 5:

$$(5) \frac{V_{2f}^1}{V_{2f}^2} = \frac{I_{2f}(A_0^1)}{I_{2f}(A_0^2)} = \frac{2J_2(A_0^1)\cos(2\Omega t)}{2J_2(A_0^2)\cos(2\Omega t)} = \frac{J_2(A_0^1)}{J_2(A_0^2)}$$

Assume that one of the retardation settings is the half-wave calibration setting and the other set-

Figure 8. Determining the Controller Settings for which $J_0 = 0$.

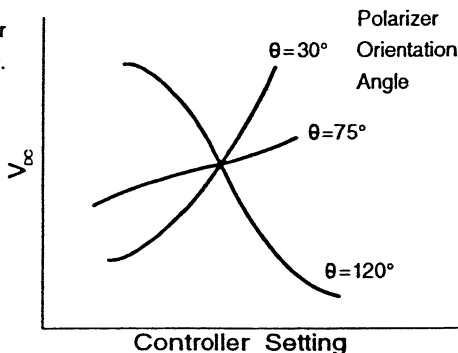

ting is at somewhat less retardation. (Quarter-wave retardation is a good example.) Equation 5 may be rewritten as follows:

$$V_{21}(\lambda/4) = V_{21}(\lambda/2) \frac{J_2(\pi/2)}{J_2(\pi)}$$

half-wave retardation: $A_0 = \pi$

quarter-wave retardation: $A_0 = \pi/2$

The method is simple:

1. Using an oscilloscope, determine the half-wave calibration condition.
2. Read the lock-in amplifier reading and compute the expected lock-in reading for quarter-wave retardation.
3. Adjust the controller until this lock-in output is obtained. The modulator will then be correctly set for quarter-wave operation.

A sample calculation is given below, for quarter-wave retardation.

The required Bessel functions are:

$$\text{For half-wave: } J_2(\pi) = 0.485$$

$$\text{For quarter-wave: } J_2(\pi/2) = 0.250$$

The required setting for quarter-wave retardation is:

$$V_{21}(\lambda/4) = \frac{J_2(\pi/2)}{J_2(\pi)} V_{21}(\lambda/2) = .515 V_{21}(\lambda/2)$$

$V_{21}(\lambda/2)$ is the lock-in reading for half-wave retardation, as set by the oscilloscope.

Reference:

1. Kemp, James C., *Polarized Light and its Interaction with Modulating Devices*, Hinds International, Inc., 1987.

MODULATED INTERFERENCE EFFECTS WITH LASERS

by Dr. Theodore Oakberg

In many respects lasers make ideal light sources for use with photoelastic modulators: they are highly monochromatic, well collimated intense sources of spectral line radiation. They can frequently be used without any focussing optics.

The extremely narrow spectral bandwidths of lasers can lead to a problem of modulated interference effects. These effects generate spurious signals at exactly the frequencies of interest in modulator experiments, and are therefore very troublesome. They can easily have magnitudes greater than the signal being studied.

It should be noted that these effects are not important with any other light sources, even spectral light sources such as mercury arc lamps and gas discharge tubes.

INTERFERENCE IN MODULATOR OPTICAL ELEMENTS

Figure 1 shows the multiple reflection conditions which produce interference. Most of the incident laser energy passes through the optical element without attenuation, the "Primary Beam". A small amount of the light (about 4% for fused silica) is reflected at the second surface. The same fraction of this light is again reflected at the first surface, and forms a "secondary beam" travelling in the same direction as the primary beam. The secondary beam, for fused silica, has an intensity of about 0.16% of the first beam.

The secondary beam travels a

optical path (distance times refractive index) of $2dn$ more than the primary beam. (Here d is the thickness of the optical element and n is its refractive index.) This difference between the primary and secondary beam paths is called the "path difference".

The conditions for interference is given below. For constructive interference (bright fringe) the path difference must be equal to:

$$2dn = m \quad \text{where } m \text{ is an integer}$$

For destructive interference (dark fringe) the path difference must be equal to:

$$2dn = (m + 1/2) \quad \text{where } m \text{ is an integer}$$

For modulator optical elements these integer values are very large, (e.g. 30,000), but the laser spectral line widths are so sharp that these interference effects are still very strong.

MODULATION OF INTERFERENCE EFFECTS - RECTANGULAR MODULATORS

Hinds "Series I" modulators use optical elements in the shape of a rectangular bar. A standing sound wave is set up in the bar. The thickness of the bar varies sinusoidally at the modulator reference frequency. (Figure 2.)

A thickness change of the order of a wavelength of light can cause the interference condition to go from constructive to destructive and back again. This will be observed by a detector as an intensity modulation at

Figure 1. Multiple Reflections of Laser Beam.

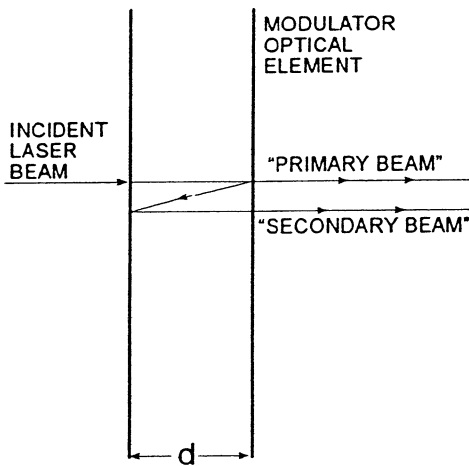

Figure 2. Relative Motion of Optical Element Surfaces.

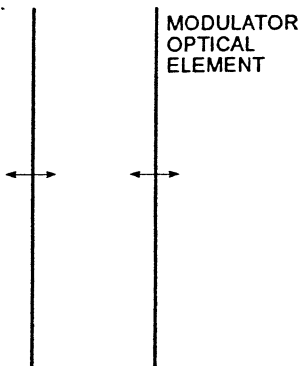
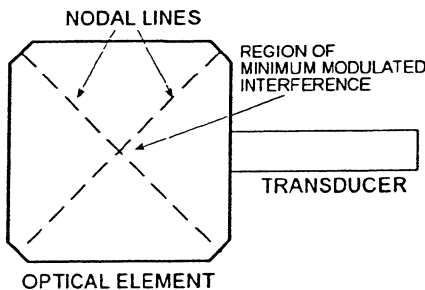

Figure 3. Octagonal Modulator Optical Element.



the modulator frequency, or twice the modulator frequency, etc.

An interesting test for modulated interference may be made by removing all polarizers from an optical setup. Under this condition, none of the desired polarization effects can be observed with the modulator. If the modulated intensity is still detected at approximately the same amplitude, the source of the modulation is interference effects.

MODULATED INTERFERENCE WITH SERIES II (OCTAGONAL) MODULATORS

Octagonal modulators are less susceptible to modulated interference effects than are rectangular modulators. The standing sound wave in an octagonal modulator is a "two-dimensional" sound wave. Figure 3 shows two "nodal lines" along which there is no net relative motion of the two optical element surfaces. Therefore, the interference effects are not modulated.

The intersection of the two nodal lines marks a region where this relative motion is absent, therefore modulated interference is strongly suppressed or absent.

In order to suppress modulated interference using an octagonal modulator, the modulator must be carefully positioned so that the beam passes through the proper part of the modulator optical element. As a rule this must be determined experimentally. A two-dimension

translation stage is very useful in making this adjustment.

USE OF ANTI-REFLECTIVE COATINGS

For Series I (rectangular) modulators, anti-reflective (AR) coatings may be used to significantly reduce modulated interference. The optical element may be regarded as a poor Fabry-Perot etalon or interferometer. With a Fabry-Perot instrument, the quality of the interference fringes is a direct function of the surface reflectivity. The lower this reflectivity, the weaker the interference effects will be.

AR coatings are most effective if a single laser wavelength is to be used. In this case a "V-coat" AR coating may be specified. These typically have a reflectance per surface of less than 0.1% for fused silica optical elements. Broad band coatings could be expected to have reflectance per surface in the 0.2-0.3% range.

It should be noted that outside the spectral band of the AR coating, interference effects may be worse than with an uncoated modulator.

HINDS ENGINEERING SUPPORT

The engineering staff at Hinds Instruments is available to assist modulator users with modulated interference problems which they may encounter in their experiments. Normally there is no charge for this service.

LINEAR BIREFRINGENCE AND OPTICAL ROTATION

by Dr. Theodore Oakberg

Linear birefringence refers to slight differences in the refractive index of a material depending on different linear polarization states of light. A photo-elastic modulator may be used to measure low levels of linear birefringence such as may be encountered in optical components.

Optical rotation, sometimes called circular birefringence, refers to a slight difference in the refractive indices for the two senses of circularly polarized light. This results in the rotation of the plane of polarization of linearly polarized light passing through an "optically active" material. This rotation can be measured at high sensitivity using a PEM-based system. It is particularly effective for small rotation angles. Optical Rotary Dispersion (ORD) is the study of optical rotation as a function of wavelength of light.

Although similar in concept, the techniques for measuring these two phenomena are somewhat different, and they are described in different sections of this application note.

LINEAR BIREFRINGENCE

This application note describes systems which can be used in the measurement of optical elements such as windows, lenses, etc. Retardation levels due to birefringence are assumed to be less than a quarter of the wavelength of the light being used for the measurement. Beam deflection is assumed to be negligible for these small birefringence levels.

Figure 1 shows some geometri-

cal concepts needed for discussion of retardation measurement in a flat sample such as a window. The sample is assumed to be oriented normally to the optic axis of the measuring system. The sample will have two birefringent axes, a "fast axis" and a "slow axis" oriented at 90 degrees from each other. At 45 degrees from these axes will be two "null axes." A complete measurement of the retardation of a window includes determining the magnitude of the retardation and the direction of the fast and slow axes for the sample. Note that the magnitude and direction of the retardation may vary across the face of the sample.

Figure 1. Axes of a Birefringent Sample.

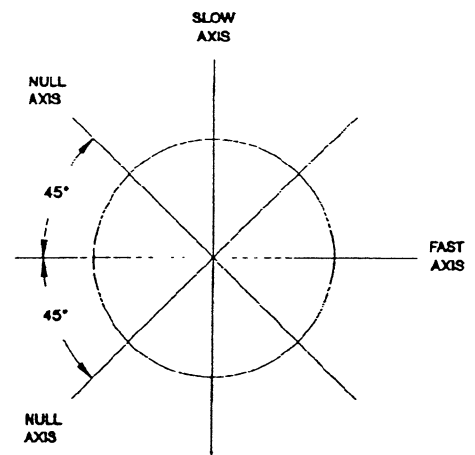

A SIMPLE APPARATUS FOR BIREFRINGENCE MEASUREMENT

A simple apparatus for birefringence measurement is described in Figure 2. Hinds strongly recommends use of a vertical optical bench setup when working with

small samples such as windows, lenses, etc. A simple shelf (with a hole in it for the light beam) can then be used to support the sample.

A rotation stage may be needed in order to position the sample for maximum birefringence signal and to determine the orientation of the axes. The center of rotation of the stage must accurately coincide with the optical axis of the system.

Figure 2. Simple Setup for Measuring Birefringence.

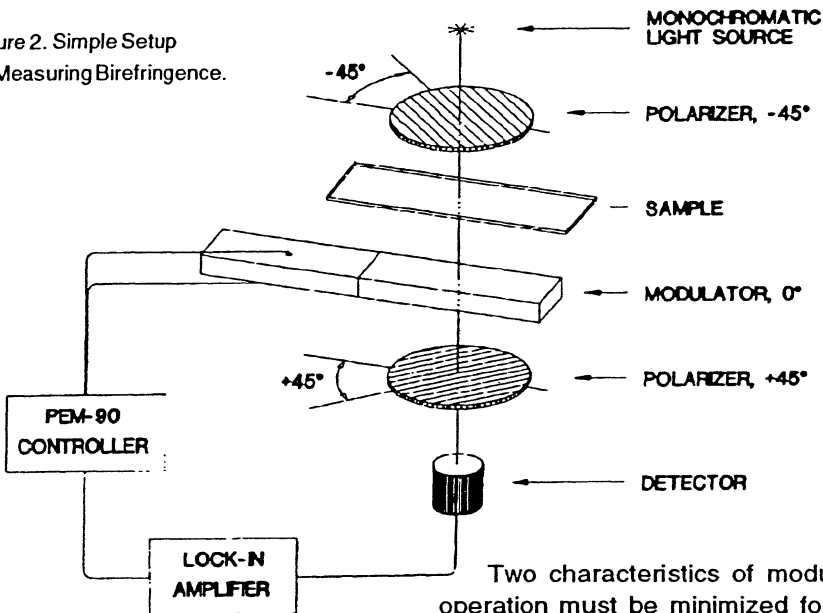

Two characteristics of modulator operation must be minimized for high sensitivity measurement of birefringence. The first is the residual birefringence of the modulator optical element. Hinds has proprietary techniques for reducing birefringence in modulator optical elements to a very low level (retardation less than 0.1 nanometer). A low level of birefringence should be specified when ordering a modulator for birefringence measurement use.

The second characteristic is an interference effect caused by multiple reflections from the optical element surfaces. This is an important consideration if a laser is used as a light source, but is negligible if low coherence light sources are

used (e.g. a mercury lamp). An antireflection coating tuned to the laser frequency should be specified when ordering.

A calibrator, a waveplate whose retardation is known accurately at the wavelength of measurement, may be used to calibrate the system. A retarder plate with retardation of 1/30 wave will provide linearity within one percent.

The modulator is traditionally operated at quarter-wave peak retardation for simple setups such as this. The electrical signal proportional to the retardation will be detected at the modulator frequency (1f) with the lock-in amplifier. The sample must be rotated until a maximum signal is obtained. The angular position of the sample will indicate the birefringent axes.

For small values of retardation (equal to or less than the calibrator) the retardation may be determined by a simple ratio:

$$B_{\text{sample}} = B_{\text{standard}} \frac{V_{1f(\text{sample})}}{V_{1f(\text{standard})}}$$

In the equation above, B is the retardation measured in any convenient units.

IMPROVEMENTS

A general expression for the light intensity at the detector for the setup in Figure 2 has been derived by Kemp.¹

$I'' = 1 - \cos(B)\cos(A) + \sin(B)\sin(A)$ where $A = A_0\cos(\Omega t)$. A Fourier Series expansion of this equation yields the following expression.

$$I'' = \frac{1 - \cos(B)J_0(A_0)}{\text{DC}} + \frac{2\sin(B)J_1(A_0)\cos(\Omega t)}{1f} + \frac{2\cos(B)J_2(A_0)\cos(2\Omega t)}{2f} + \text{(higher order terms)}$$

The DC term, the first harmonic term, and the second harmonic terms are all identified. The following equations may be written, where the constant of proportionality K is the same for all three equations.

$$V_{DC} = K(1 - \cos(B))J_0(A_0)$$

$$V_{1(\text{peak})} = 2K\sin(B)J_1(A_0)\cos(\Omega t)$$

$$V_{2(\text{peak})} = 2K\cos(B)J_2(A_0)\cos(2\Omega t)$$

Note that if A_0 is chosen such that $J_0(A_0) = 0$, then the DC or average signal is independent of the birefringence B. This occurs for $A_0 = 2.405$ radians (approximately 0.383 waves). The DC signal may therefore be used to "normalize" the 1f and 2f signals, as

$$\frac{V_{1(\text{peak})}}{V_{DC}} = 2\sin(B)J_1(A_0)$$

$$\frac{V_{2(\text{peak})}}{V_{DC}} = 2\cos(B)J_2(A_0)$$

In the above equations V_{1f} and V_{2f} are peak voltages, representing

the amplitudes of the signal waveforms. The lock-in amplifier presents RMS voltages, however. For sinusoidal waveforms, these voltages are related by

$$V_{RMS} = \frac{V_{(\text{peak})}}{\sqrt{2}}$$

The ratios are defined by the equations

$$R_{1f} = \frac{V_{1f(RMS)}}{V_{DC}} = \sqrt{2}\sin(B)J_1(A_0)$$

$$R_{2f} = \frac{V_{2f(RMS)}}{V_{DC}} = \sqrt{2}\cos(B)J_2(A_0)$$

Solving for the birefringence

$$B = \sin^{-1} \left[\frac{R_{1f}}{\sqrt{2}J_1(A_0)} \right] \text{ or}$$

$$B = \cos^{-1} \left[\frac{R_{2f}}{\sqrt{2}J_2(A_0)} \right]$$

The circuit in Figure 3 allows normalization of the harmonic signals. The signal conditioning module is manufactured by Hinds, Model SCM. It derives, from the detector output, a low-pass DC signal and a broadband AC signal. The Stanford Research SR510 lock-in amplifier has a built-in ratio circuit for deriving the normalized signal.

This experimental setup is useful for samples in which the direction of the birefringence is known beforehand to within a few degrees. The magnitude can then be obtained directly. If the fast axis direction is not known, the sample must be rotated about the optic axis until the maximum 1f signal is obtained. The orientation of the birefringence is determined by this angular position.

SIMULTANEOUS DETERMINATION OF BIREFRINGENCE MAGNITUDE AND DIRECTION

The need for the rotation of the sample to determine both magnitude and orientation of the retardation can be eliminated by methods described

Figure 3. Birefringence Measurement, direction known.

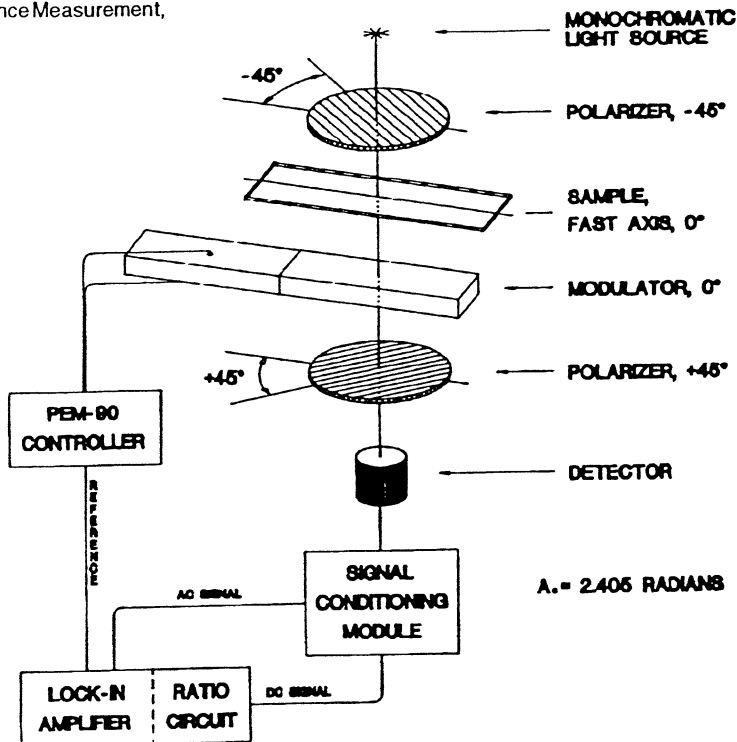

by Paul Frattini² and Shirley Johnson³. Johnson's method will be described here since the equations she developed can be more easily solved, and since there are no angles for which the equations become divergent.

The experimental setup is described as follows. Important features include the addition of two quarter-waveplates and use of a second polarizer whose axis is not at right angles with the axis of the first polarizer.

The equations which determine the angle and magnitude of the birefringence are given below. θ is the angle between the birefringent axis and the fast axes of the quarter-wave plates. The birefringence angle is determined first. With computer analysis, a selection between the second and third equations is used

to determine the magnitude of the retardation, depending on the angle of the birefringent axes.

$$\theta = 1/2 \tan^{-1} \left[\frac{J_2(A_0)R_{11}}{J_1(A_0)R_{21}} \right]$$

$$\text{and } B = \sin^{-1} \left[\frac{R_{11}}{\sqrt{2} J_1(A_0) \cos 2\theta} \right]$$

$$\text{or } B = \sin^{-1} \left[\frac{R_{21}}{\sqrt{2} J_2(A_0) \sin 2\theta} \right]$$

If speed is not a primary concern (i.e. several seconds can be devoted to each measurement) then a single lock-in amplifier could be used to perform both measurements, with the computer switching the lock-in between appropriate settings for the 1f and 2f signals.

For fast repetitive measurements, two lock-in amplifiers would be preferred, as shown in Figure 4.

Figure 4. Setup for Simultaneous Measurement of Birefringence Magnitude/Direction.

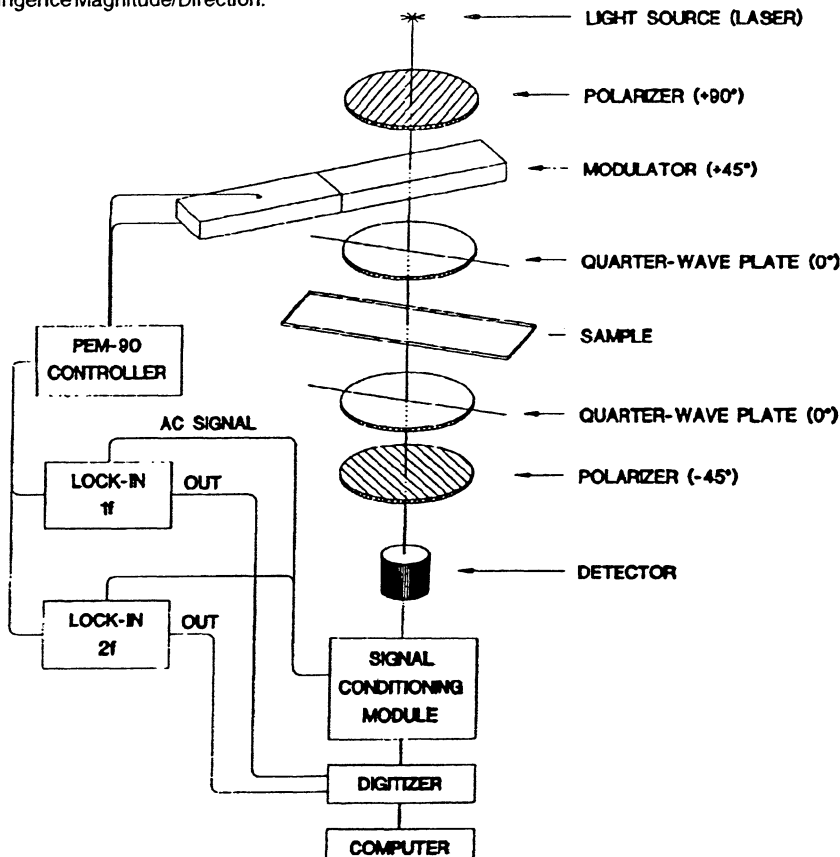

OPTICAL ROTATION

Optical rotation is sometimes called "circular birefringence" as described in the next paragraph. Detection schemes are somewhat different than for linear birefringence, and two such methods will be described.

A monochromatic, plane-polarized beam of light may be represented mathematically as resulting from the superposition of two components of circularly polarized light (right and left hand senses), with identical amplitude and frequency or wavelength. The plane of polarization is determined by the relative phase of the two circular polarization components. A rotation of the plane of polarization (change in phase between the circular components) will be induced if the refractive indices for a sample are slightly different for the two senses of circular polarization.

Figure 5. Measurement of Optical Rotation, Method 1.

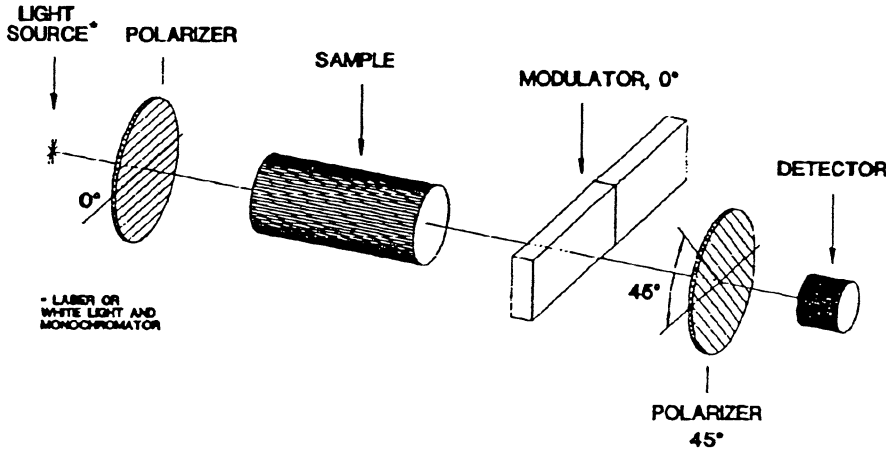

The most straightforward setup for measuring optical rotation is shown in Figure 5. The polarizer is oriented precisely parallel to the modulator axis. If no rotation occurs, no component of the polarization at 45° to the modulator axis will occur, hence no 2f signal will be detected by the detector. Any rotation would result in a signal which (for small angles) is proportional to the angle of rotation. The signal normalization techniques described in the previous section would be beneficial to ensure that the output does not depend on light source intensity, changes in optical transmission, etc.

This setup is appropriate for measuring Optical Rotary Dispersion (ORD) which is the study of optical rotation vs. wavelength of light. (Refer to the Spectrometer Integration Application Note.) A computer controlled system could control the

Figure 6. Measurement of Optical Rotation, Method 2.

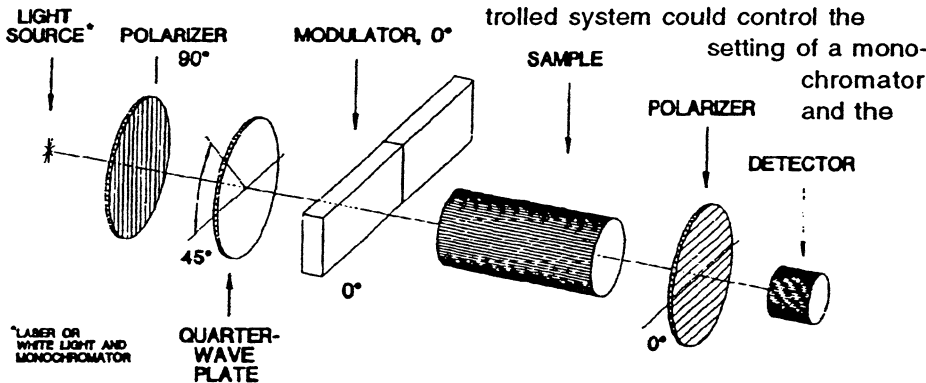

wavelength input to the PEM-90. Polarizers are inherently achromatic devices.

Another setup for measuring optical rotation has been suggested by Kemp⁴. The experimental setup is shown in Figure 6.

In this, a quarter-wave plate is inserted between the initial polaroid and the modulator. The plate is oriented with its fast axis rotated 45° (around the light axis) from the polarizer passing axis, such that the waveplate and polaroid acts as a circular polarizer.

The circularly polarized light is converted by the PEM to light which switches between linearly polarized states, at the modulator frequency, alternatively polarized along +45° and -45° relative to the transverse PEM axis. This light traverses the sample, then a second polarizer with its passing axis oriented *parallel* to the PEM axis.

With no sample or no optical rotation, no signal at the modulator frequency is generated. A finite optical signal produces an output signal which is proportional to the rotation angle if the latter is small.

References:

1. Kemp, James C., *Polarized Light and its Interaction with Modulating Devices*, Hinds International, Inc., 1987.
2. Frattini, Paul L., *Rheo-optical Studies of Sheared Suspensions Using Linear Dichroism*, Ph.D. Thesis, Chemical Engineering Department, Stanford University, September 1985.
3. Johnson, Shirley J., *Simultaneous Dichroism and Birefringence Measurement of Dilute Colloidal Suspensions in Transient Shear Flow*, Engineer Degree Thesis, Chemical Engineering Department, Stanford University, September 1984.

LINEAR & CIRCULAR DICHROISM

by Dr. Theodore Oakberg

The PEM-90™ photoelastic modulator is well suited for experiments which measure linear dichroism (LD) or circular dichroism (CD). The modulator has an RS-232 computer interface which enables the peak retardation level to be varied under computer control in synchronization with a scanning monochromator. The interface allows the computer to monitor the status of the modulator as well.

Linear dichroism is the differential absorption between two orthogonal components of linear polarized light.^{1,2} This phenomenon occurs with certain natural crystals, with stretched polymers and with other non-isotropic samples. The techniques for **reflectance difference spectroscopy** are similar to linear dichroism.

Circular dichroism is the differential absorption between left and

right circular polarized light components. This occurs naturally with chiral compounds, that is, those molecules which exhibit "mirror isomerism" (left and right-handedness).

Both LD and CD can be measured with the same apparatus, shown below.

Light from the monochromatic light source is polarized at an angle of 45° with respect to the modulator axis. Light coming from the modulator alternates between two orthogonal linear polarization states, or between the two senses of circular polarized light, depending on the peak retardation of the modulator.

For linear dichroism the sample should be oriented so that a natural dichroic axis is at 45° to the modulator axis. The detector output is an electrical signal whose average (DC) voltage is proportional to the amount

Experimental Setup for Linear and Circular Dichroism.

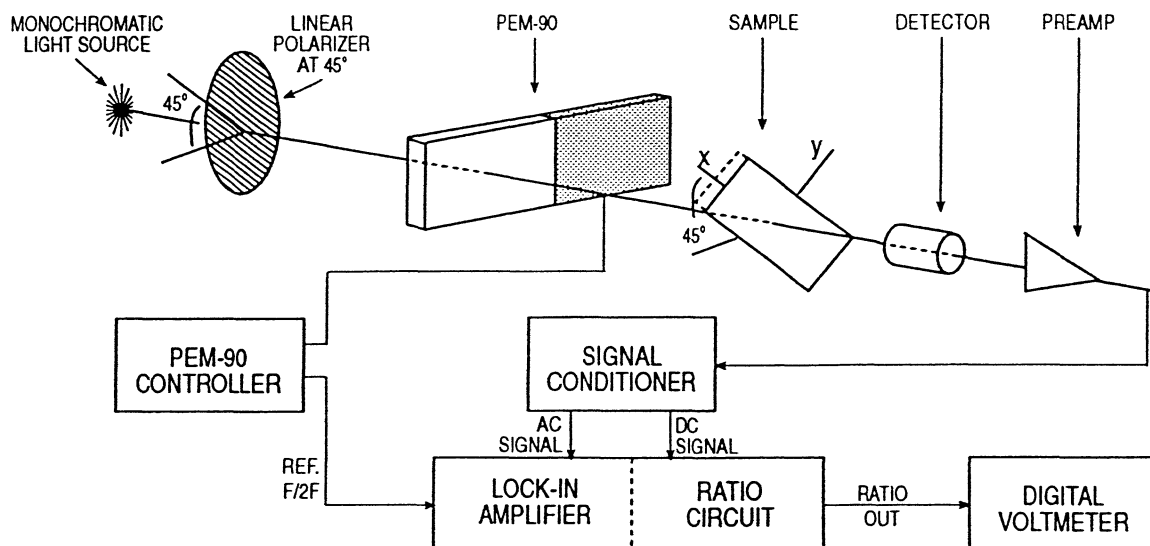

of light reaching the detector. The AC portion of the signal (proportional to the LD effect) is at twice the modulator frequency (2f).

No special orientation is needed for circular dichroism samples. The AC signal (proportional to the CD effect) is at the modulator frequency (f). The average or DC voltage is proportional to the amount of light reaching the detector.

The preamplifier provides current to voltage conversion and buffers the output for wide frequency response. (Hinds provides two detector systems, silicon photodiode and photomultiplier which provide proper impedance matching and frequency response, e.g. DC to 500 kHz.) The PEM-90 controller determines the peak retardation of the modulator. This is traditionally chosen to be half-wave retardation for LD experiments and quarter-wave retardation for CD measurement. Use of an intermediate value of retardation (0.383 waves) permits simultaneous measurement of LD and CD.¹

The signal conditioner (Hinds Model SCU-001) provides amplification and derives a broad-band AC signal and a low-pass or DC signal. The AC signal goes to a lock-in amplifier, where detection of the signal is accomplished by phase sensitive

detection, using a reference signal (f or 2f) from the modulator controller. The output is an analog voltage proportional to the desired f or 2f signal component.

The electrical signal obtained from the lock-in amplifier is dependent on the intensity of the light used in the experiment. Dividing the lock-in amplifier output by the DC or low-pass signal from the lock-in gives a signal which is directly proportional to the desired LD or CD effect. This may be expressed by the relationship

$$LD \propto \frac{V_a}{V_{oc}} \quad \text{or} \quad CD \propto \frac{V_l}{V_{oc}}$$

The calculation of the ratio of the AC voltage and the DC voltage may be done using a ratio circuit (such as is provided in many commercial lock-in amplifiers) or may be done in a computer, after the AC and DC signal components have been digitized.

References:

1. Hips, K.W. and Crosby, G.A., *Applications of the Photoelastic Modulator to Polarization Spectroscopy*, Journal of Physical Chemistry, **83**, 555, 1979.
2. Drake, Alex F., *Polarisation modulation—the measurement of linear and circular dichroism*, J. Phys. E: Sci Instrum. **19** 1986.

STOKES POLARIMETRY

by Dr. Theodore Oakberg

James Kemp's version of the photoelastic modulator was invented for use as a polarimeter, particularly for use in astronomy. The basic problem is measuring net polarization components in what is predominantly an unpolarized light source. Dr. Kemp was able to measure a polarization component of light less than 10^6 below the level of the total light intensity.

The polarization state of a light source is represented by four numerical quantities called the "Stokes parameters."^{1,2} These correspond to intensities of the light beam after it has passed through certain devices such as polarized prisms or films and wave plates. These are defined in Figure 1.

To many scientists a polarimeter is a device for measuring a change in the plane of polarization of a linearly polarized light beam. For small angle rotations, this measurement can be done more simply and with greater precision using the techniques described in the application note "Linear Birefringence and Optical Rotation."

SIMPLIFIED POLARIMETER

A simplified polarimeter optical setup is shown in Figure 2. This setup would be suitable for situations in which the direction of the linear polarization component is known beforehand. The polarimeter should be aligned so that the passing axis of the modulator is at 45

Figure 1. Definition of the Stokes Parameter.

I = total intensity of light beam

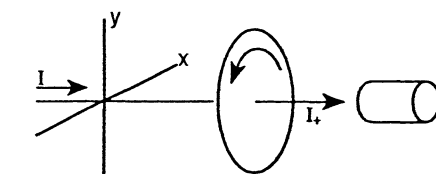
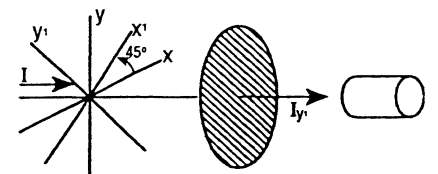
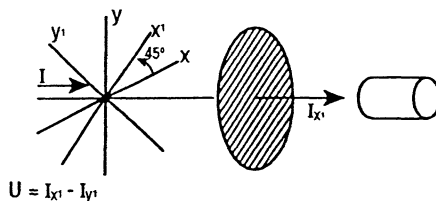
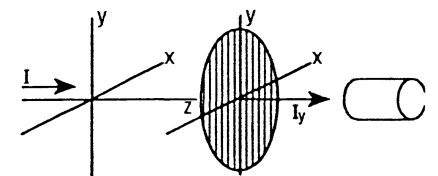
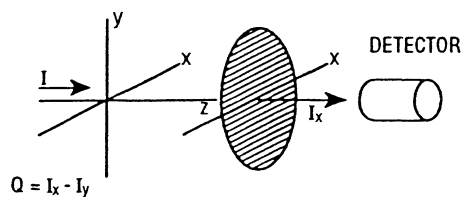

$V = I_t - I$

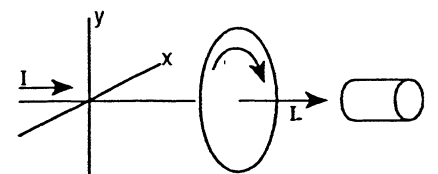

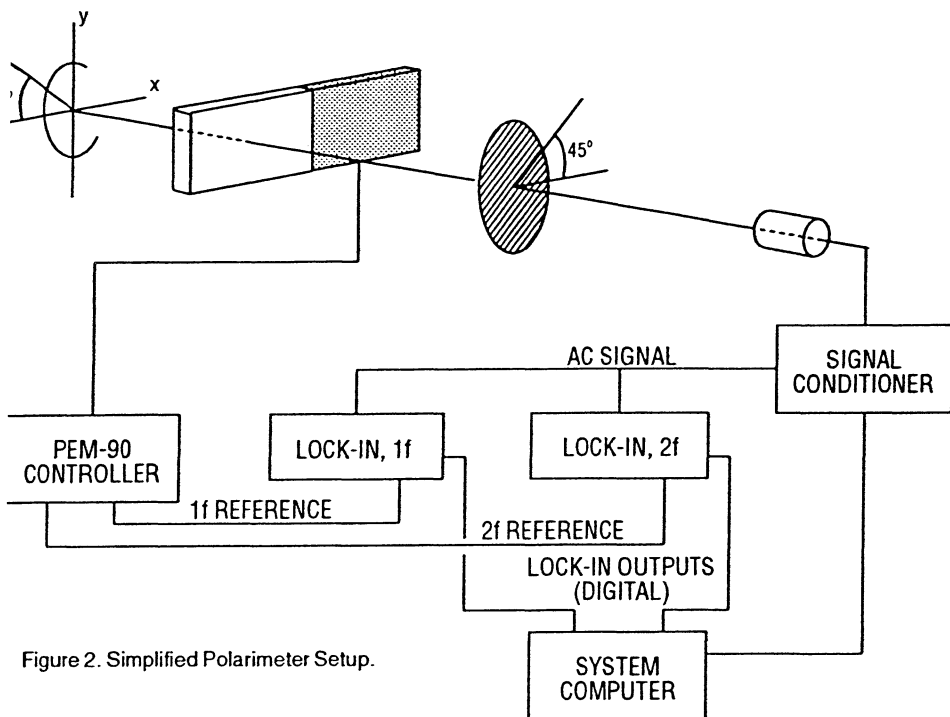

Figure 2. Simplified Polarimeter Setup.

degrees to the known linear polarization direction, as shown. The polarizer is oriented at right angles to the plane of the incident linear polarization component.

The circular polarization component will produce a signal at the modulator frequency, 1f. If the sense of the circular polarization is reversed, this will be shown by an output of opposite sign from the lock-in amplifier. This signal is proportional to Stokes Parameter V.

The linear polarization component will give a signal at twice the modulator frequency, 2f. A linearly polarized component at right angles to the direction shown will produce a lock-in output with opposite sign. This signal is proportional to Stokes Parameter U.

A linear component of polarization which is at 45 degrees to the direction shown will produce no 2f signal in the lock-in amplifier. If there is no such component, the Stokes parameter Q is zero. If there is such

a component, this simplified polarimeter cannot detect it.

Figure 1 assumes that the light source is monochromatic or nearly so. PEM-based modulators need some spectral selection of the light being measured. If a wavelength-selecting device such as a monochromator or interference filter is used, it should be placed between the polarizer and the detector.

GENERAL POLARIMETER

The setup above is not sufficient for determining the complete polarization state in situations where the linear polarization direction is not initially defined. Thus, two measurements at 45 degrees with respect to each other must be made. This is a requirement of all general purpose polarimeters.

With a PEM, there are at least two ways of accomplishing this. The first method is to provide a means of rotating the entire polarimeter apparatus (Figure 2) through 45 degrees. A measurement in each of the two positions must be made. This is an acceptable and straightforward method provided that the light source is steady and does not change over the time required for both measurements.

Two photoelastic modulators may be used to provide a polarimeter with "real time" measurement capability. The two modulators are mounted with their modulator axes at 45 degrees with respect to each other.

The polarizer is mounted with its passing axis between the two modulator axes, or at 22.5 degrees with each modulator axis. The modulators must operate at different frequencies, typically a frequency separation of 2 to 5 kHz is used. Each modulator has its own pair of lock-in amplifiers.

Fractional polarizations:	
$Q \propto V_{2f}(0^\circ)$	linear polarization = $\frac{\sqrt{Q^2 + U^2}}{I}$
$U \propto V_{2f}(45^\circ)$	
$V \propto V_{1f}(0^\circ) = V_{1f}(45^\circ)$	circular polarization = $\frac{V}{I}$
$\Theta = \frac{1}{2} \tan^{-1}\left(\frac{U}{Q}\right)$	

Table 1. Stokes Parameters with Rotating Polarimeter.

The outputs of the two modulator systems are equivalent to the two measurements with the rotator-based system.

The measurement of the Stokes parameter I could in principle be accomplished by using a single detector with an optical system to restrict the field of view and to select the appropriate spectral bandwidth.

There is much benefit to measuring I through the same optical system as the polarimeter. This could be accomplished in a number of ways. One would be to replace the analyzing polarizer with a polarizing beam-splitter and another detector. The Stokes parameter I would be proportional to the sum of the two detector signals (DC components).

For systems designed to work with monochromatic (or nearly so) light sources, waveplates may be used to reduce system complexity. These are discussed in the section "Use of Waveplates."

ROTATOR-BASED POLARIMETER

For a rotator-based polarimeter, the modulator, polarizer and other detector would be mounted so they can be rotated together. Two measurements would be taken, with the angular positions of the polarimeter assembly differing by 45 degrees. Modern systems would utilize a computer which would drive a motorized rotator and also process the data from the lock-in amplifiers and the DC meter.

The relationships between the electronic outputs of the lock-ins and the DC meter, and the polarization state of the light source are given in Table 1 above.

By using computer control of a single lock-in amplifier, it would be possible to make both 1f and 2f measurements sequentially.

DUAL MODULATOR POLARIMETER

Figure 3 shows the optical configuration for a dual-modulator polarimeter. As mentioned, the modulator axes of the two modulators are at 45 degrees, with the polarizer passing axis at 22.5 degrees with each modulator. The angular designations for each modulator are determined by which angular direction of polarized light each modulator subsystem is sensitive to.

The electronic block diagram corresponds to the one given in Figure 1, in duplicate.

The relationships between the electronic output voltages and the appropriate polarization parameters are given in Table 1.

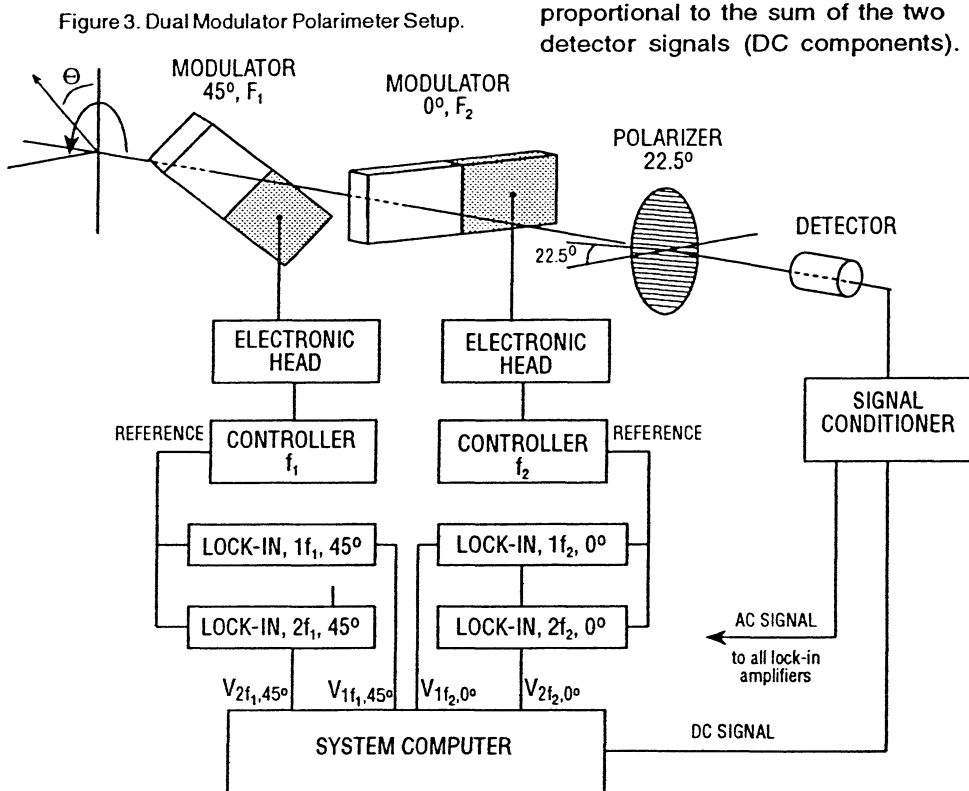

Figure 3. Dual Modulator Polarimeter Setup.

USE OF WAVEPLATES

If the light source being measured is monochromatic or nearly so, waveplates may be used to simplify the polarimeter system significantly. Two such uses are described below.

Polarimeter Using Half-Wave Plate.

Rotating a small component such as a waveplate is much simpler than rotating a whole polarimeter apparatus. The half-wave plate exhibits the property of rotating any linear polarization component to the opposite side of the fast axis.

The half-wave plate is placed initially with its fast axis parallel to the modulator axis. In this position Q and V may be measured, although the algebraic signs of the lock-in outputs will be reversed, compared with the polarimeter without the waveplate.

The waveplate is then rotated by 22.5 degrees for the measurement of the Stokes parameter U. Thus the 45 degree component is at 0 degrees with respect to the modulator axis, the 0 degree component is at 45 degrees. Thus the two measurements are sufficient for measuring the two linear parameters Q and U.

Linear Polarimeter Using Quarter-Wave Plate.

If linear polarimetry is intended and there is no desire to measure the circular polarization components, the addition of a quarter-wave plate can be used to make a linear polarimeter which has no moving parts.

The waveplate is then placed with the fast axis at 45 degrees with the modulator axis. The 45 degree polarization component (Stokes parameter U) is unaffected, and is detected by a lock-in amplifier at twice the modulator frequency.

The component at 0 degrees (Stokes parameter Q) is converted by the waveplate to circularly polarized light. This circular light is then detected by the lock-in amplifier at the modulator frequency.

References:

1. Kemp, James C. *Polarized Light and its Interaction with Modulating Devices — A Methodology Review*, Hinds International, Inc., January 1987.
2. Klinger, Lewis and Randall. *Polarized Light in Optics and Spectroscopy*, Academic Press, 1990.
3. Kemp, James C. "Photoelastic modulator polarimeter in astronomy," SPIE Conference, San Diego, August 1981.
4. Kemp, James C. and Barbour, Mark. *A Photoelastic Modulator Polarimeter at Pine Mountain Observatory*, Publication of the Astronomical Society of the Pacific, 93:521-525, August 1981.
5. Kemp, James C., Henson, G.D., and Powell, E.R. "The optical polarization of the sun measured at a sensitivity of parts in 10 million," *Nature*, V. 326, No. 6110, pp. 270-273, March 19, 1987.
6. Kemp, James C. "Detecting polarized light at levels below 1 ppm," SPIE Conference, Los Angeles, January 1988.

DET-90 PHOTODIODE DETECTOR/PREAMPLIFIER

Hinds Instruments Model DET-90 photodiode detector/preamplifiers are specifically designed for use in photoelastic modulator (PEM) based systems. They feature DC coupling, wide frequency response, and low impedance voltage output to drive signal coaxial cables.

DC coupling is important since many PEM applications require computing the ratio between an AC signal (as detected by a lock-in amplifier) and the DC or "average" detector output.

The frequency bandwidth of the detector should be at least several times the modulator frequency. This allows an accurate display of the modulated waveform on an oscilloscope, which is useful for retardation calibration.

The buffered low-impedance voltage output enables driving the signal coaxial cable without loss of frequency bandwidth. The output is suitable for connection to an oscilloscope, a lock-in amplifier, a signal conditioner or many other electronic instruments.

SPECIFICATIONS

Specifications and performance data are given at the end of this section, and include the following:

Table 1. Specifications and performance data (page 4).

Figure 1. Responsivity vs. wavelength for silicon detectors (page 5).

Figure 2. Responsivity vs. wavelength for germanium detectors (page 5).

Figure 3. Diagrams for photovoltaic and photoconductive circuits (page 6).

OPERATION

The solid-state photodiode detectors used in Hinds detector/preamplifier systems provide a current signal which is proportional to the intensity of UV/visible/IR light striking the detector. The integrated preamplifier performs the following functions:

1. Conversion of the current signal to a voltage signal.
2. The preamplifier output is buffered to provide impedance matching to the coaxial signal cable. This is necessary to provide adequate frequency response.

Two modes of operation are offered: photovoltaic and photoconductive. Photoconductive operation gives significantly higher "gain" or output voltage for a given light intensity, is less susceptible to saturation, and is appropriate for higher light intensities. Photovoltaic operation gives better signal-to-wave ratio and much lower intrinsic dark current.

Block diagrams of photovoltaic and photoconductive circuits are shown in Figure 3 on page 6.

Preamplifier power may be taken from a laboratory power supply, a Hinds SCU-90 signal conditioner, or a Stanford Research Systems Model SR510 lock-in amplifier. The color coding for the wires to be connected to a power supply are:

Pin one	Black	negative, -12 to 18 volts
Pin two	Red	positive, +12 to 18 volts
Pin three	Bare	shield/chassis ground
Pin four	White	signal/power ground

The detector is provided with a post mount for convenient mounting in an optical bench. For some purposes (e.g., linear or circular dichroism) it may be desirable to rotate the detector about the optic axis. A V-block mount available from many optical component suppliers would enable this operation.

The user should be aware of the effects of saturation. Saturation implies that a linear relationship between the incident light flux and the detector output electrical signal is no longer being maintained.

To avoid saturation, the user should consult the "Output Voltage at Saturation" column in Table 1 (page 4). These values have been derived from the detector manufacturers' data on saturation current. Output voltage, as measured at the detector/preamplifier output, should not exceed these values.

DC NULL ADJUSTMENTS

For many applications a linear DC response without offset (due to dark current or operational amplifier offset) is very important. A sensitive digital DC multimeter is required for the nulling adjustments. Null adjustment is provided by a multi-turn potentiometer accessible through a hole in the back of the detector enclosure.

The DC offset circuits are not intended to balance out room light, stray light, or other non-signal light input present during the experiment. These effects are best controlled by proper experiment design, operating in a dark room, etc.

For either mode of operation, it is good procedure to minimize offset from the detector/preamplifier. The procedure is simple and is given below.

1. Provide appropriate power to the detector/preamplifier assembly.
2. Connect the output of the detector/preamplifier directly to the input of the DC digital multimeter.
3. Block the light going to the detector and adjust the multi-turn potentiometer until the digital meter reads 0 millivolts. (This is the factory setting for all Hinds photodiode detector/preamplifiers.)

USER SUPPORT INFORMATION

Hinds Instruments, Inc. makes every attempt to ensure that the DET-90 Photodiode Detector/Preamplifier is a product of superior quality and workmanship. Our service personnel are available to assist you from 8:30 a.m. to 3:30 p.m. Pacific Time. Our Service Department telephone number is (503) 690-2000.

This section consists of the following items:

- A. One-Year Limited Warranty: Please read this information carefully.
- B. Return for Repair Procedure: This procedure is for your convenience in the event you must return your detector/preamplifier for repair. Follow the packing instructions carefully to protect your instrument in transit.

A. Limited Warranty

Hinds Instruments, Inc. (Hinds) warrants the DET Photodiode Detector/Preamplifier to be free from defects in materials and/or workmanship when operated in accordance with the manufacturer's operating instructions for one (1) year from the date of purchase, subject to the provisions contained herein. Hinds' warranty shall extend to the original purchaser only and shall be limited to factory repair or replacement of defective parts.

Exclusions

This warranty does not cover normal maintenance, damage resulting from improper use or repair, or abuse by the user. This warranty extends only to repair or replacement, and shall in no event extend to consequential damages. In the event of user repair or replacement, this warranty shall cover neither the advisability of the repair undertaken, nor the sufficiency of the repair itself.

THIS DOCUMENT REFLECTS THE ENTIRE AND EXCLUSIVE UNDERSTANDING OF ALL THE PARTIES, AND EXCEPT AS OTHERWISE PROVIDED HEREIN, ALL OTHER WARRANTIES, EXPRESS OR IMPLIED, PARTICULARLY THE WARRANTIES OF MERCHANTABILITY AND/OR FITNESS FOR A PARTICULAR PURPOSE, ARE EXCLUDED.

This warranty gives you specific legal rights, and you may also have other rights which vary from state to state.

B. Return for Repair Procedure

In the event of defects or damage to your unit, first call the factory Modulator Service Department. Our hours are 8:30 a.m. to 3:30 p.m. Pacific Time, Monday through Friday. Our telephone number is (503) 690-2000.

If factory service is required, return your detector/preamplifier as follows:

- a. Packing
 - wrap unit in plastic bag first.
 - pack in original shipping carton or a sturdy oversized carton.
 - use plenty of packing material.

- b. Include
 - a brief description of the problem with all known symptoms.
 - your daytime phone number.
 - your return street shipping address (UPS will not deliver to a post office box.)

- c. Shipping
 - send freight prepaid (UPS recommended)
 - insurance is recommended. (The factory can provide the replacement value of the item being shipped.)
 - COD shipments will not be accepted.

- d. Send to:
 - Modulator Service Department
 - Hinds Instruments, Inc.
 - 3175 NW Aloclek Drive
 - Hillsboro, OR 97124

If your unit is under warranty, after repair or replacement has been completed, it will be returned by a carrier and method chosen by Hinds Instruments, Inc. to any destination within the continental United States. If you desire some specific form of conveyance or if you are located beyond these borders, then you must bear the additional cost of return shipment.

If your unit is not under warranty, we will call you with an estimate of the charges. If approved, your repaired unit will be returned after all charges, including parts, labor, and return shipping and handling, have been paid. If not approved, your unit will be returned as is via UPS COD for the amount of the UPS COD freight charges.

**TABLE 1. SPECIFICATIONS AND PERFORMANCE DATA
HINDS DET-90 PHOTODIODE DETECTOR / PREAMPLIFIERS**

Model No. DET-90	Type	Spectral Range (nm)	Active Area	Surface Diameter	NEP (nominal) W/ Hz	Frequency Response	Output Voltage at Saturation
-001	Si-PC ³	350-1100	5 mm ²	0.1 in	5x10 ⁻¹³ at 850 nm	DC - 500 kHz	10 v.
-002	Si-PC	350-1100	20 mm ²	0.2 in	8x10 ⁻¹³ at 850 nm	DC - 500 kHz	10 v.
-003	Si-PV ⁴	350-1100	5 mm ²	0.1 in	6x10 ⁻¹⁴ at 850 nm	DC - 160 kHz	0.2 v.
-004	Si-PV	350-1100	20 mm ²	0.2 in	8x10 ⁻¹⁴ at 850 nm	DC - 160 kHz	0.05 v.
-005	Si-PV	200-1050	5 mm ²	0.1 in	8x10 ⁻¹⁴ at 254 nm	DC - 260 kHz	0.2 v.
-006	Si-PV	200-1050	20 mm ²	0.2 in	1x10 ⁻¹³ at 254 nm	DC - 160 kHz	0.1 v.
-007	Ge ² -PV	800-1800	3.1 mm ²	2 mm	8x10 ⁻¹³ at 1300 nm	DC - 260 kHz	

Notes: 1. Silicon
2. Germanium
3. Photoconductive
4. Photovoltaic

Power Requirements: +/- 12 to 18 volts DC with ground
Dimensions: 2 1/2 in. diameter x 2 5/8 in. length overall
Drilled and tapped for mounting post (included)

Figure 1. Responsivity of Red/IR and UV Enhanced Silicon Photodiode Detectors.

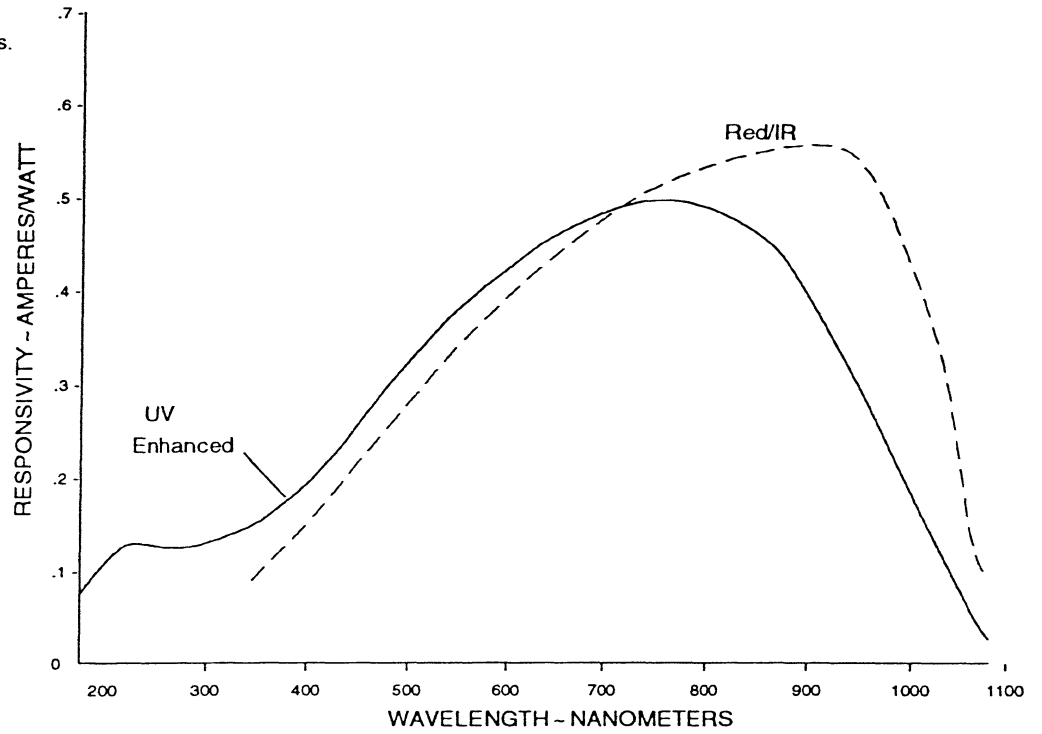

Figure 2. Responsivity vs. Wavelength of Germanium Photodiode Detectors.

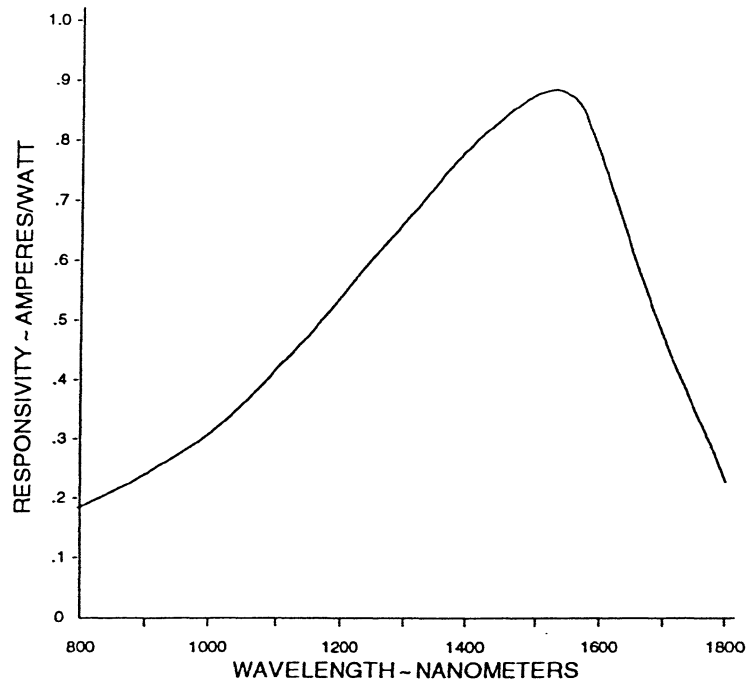
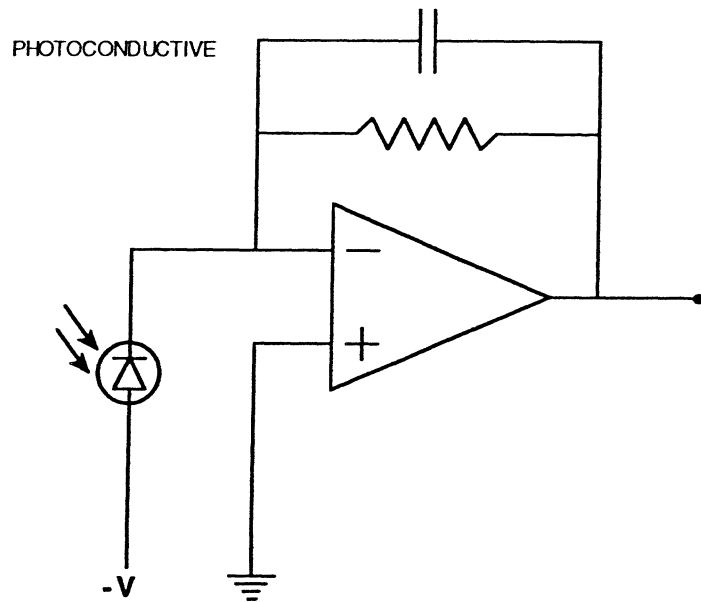
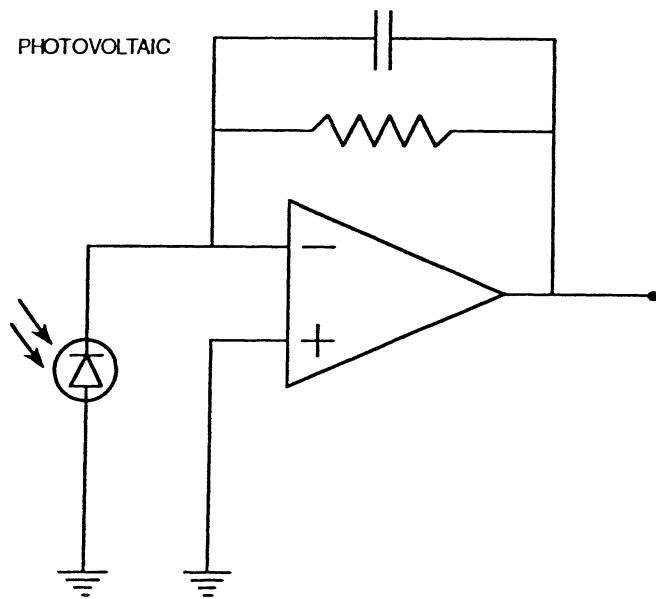

Figure 3. Block Diagrams of Photovoltaic and Photoconductive Detector Circuits.



SCU-90 SIGNAL CONDITIONING UNIT

USING THE HINDS MODEL SCU SIGNAL CONDITIONING UNIT

Many applications of the photoelastic modulator require computation of the ratio of the AC voltage component of the signal (as detected by a lock-in amplifier) to the DC or average voltage component. This computation is required for measurement of linear and circular dichroism. It can also be a significant design improvement in many other experimental setups.

The Signal Conditioning Unit (SCU) is designed to derive a broadband AC signal for input to a lock-in amplifier and a DC or low-pass signal for calculating the ratio V_{AC}/V_{DC} . It also provides amplification for the AC and/or DC signals. It provides +/-18 volt power for detector preamplifiers.

Specifications

Input Impedance	1 kohm
Output Impedance	50 ohms
AC Gain	1-20
DC Gain	10-1000
	(independent AC and DC gain configuration)
AC Frequency Bandwidth . .	250 kHz at a gain of 5
DC Time Constant	0.3, 1.0, 3.0, 10.0 seconds, selectable
Modes of Operation	Independent AC and DC gain adjustments
	Common AC and DC gain adjustments

Block Diagram and Description

A block diagram of the Signal Conditioning Unit appears on the next page. The diagram shows both the AC and DC amplification channels.

MODES OF OPERATION

There are two modes of operation for the signal conditioner. The mode of operation is selected by an internal jumper.

Input Mode

In the "Input" mode, the input to the first DC stage is taken directly from the input of the signal conditioner. The AC and DC gain settings are independent in this mode of operation. AC gain varies from 1 to 20. The DC range varies from 10 to 1000.

Signal conditioner units are shipped set up for Input mode operation.

Stage 1 Mode

In the "Stage 1" mode, the input to the DC circuit is taken from the output of the first gain stage of the AC circuit. The "AC Gain" adjustment provides a gain adjustment which is common for both the AC and DC channels. The gain for the DC channel is the product of the "AC stage" and the "DC stage" gains and varies between 10 and 20000. The input selector switch must be set to DC coupling.

Figure 1. SCU-90 Block Diagram.

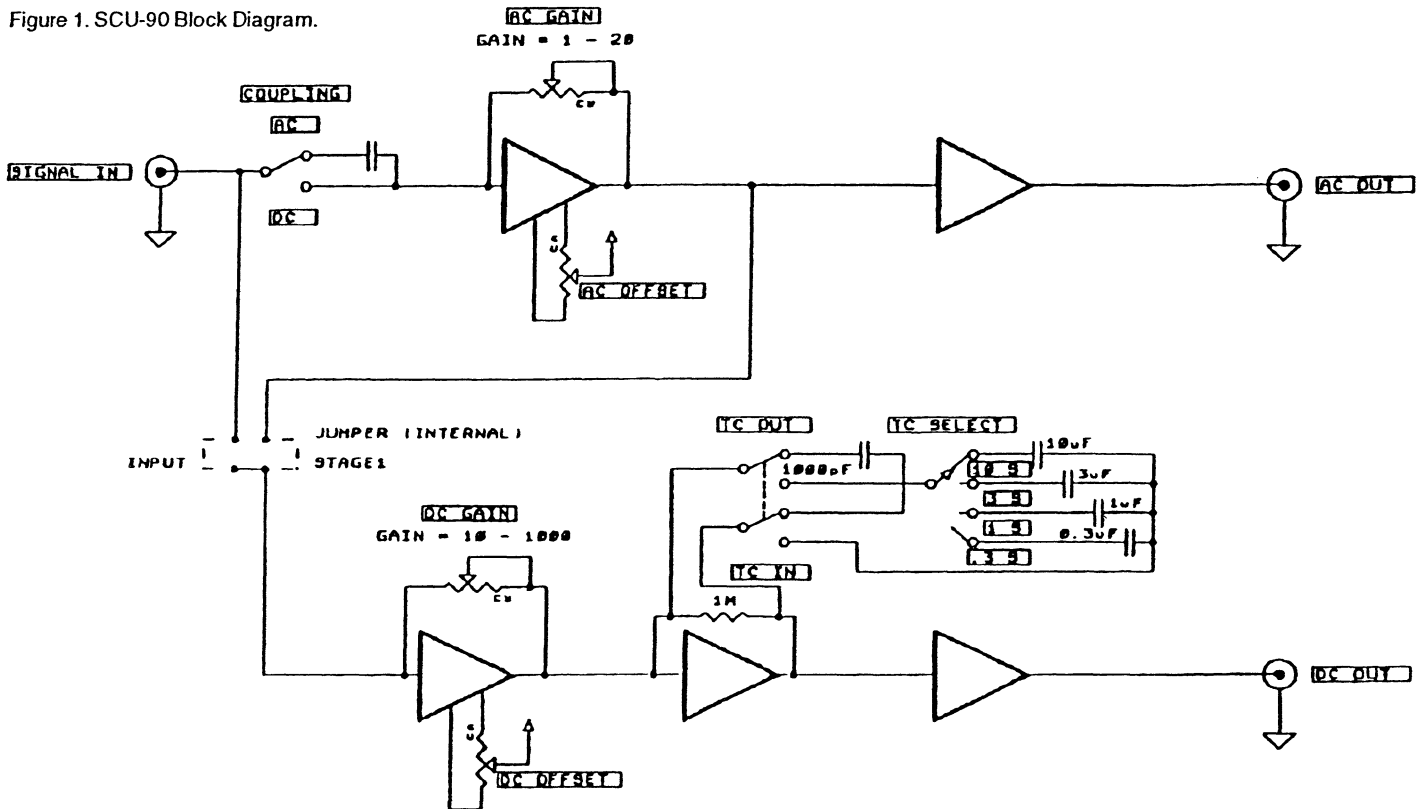

AC Circuit Description

The input to the AC circuitry may be either AC or DC coupled. AC coupling is typically used for the Input mode of operation, as it may help to prevent overloading of the AC input amplifier by high levels of DC bias.

The gain of the AC circuit may be adjusted by an internal multi-turn trimpot which is accessible from the front panel of the SCU.

The second stage is a buffer with unity gain for driving the output coaxial cable. The output is 180° out of phase with the input signal.

DC Circuit Description

The gain of the DC circuit may be adjusted by an internal multi-turn trimpot for the first stage which is accessible from the front panel of the SCU.

The second stage determines the time constant for the DC circuitry. This is switch selectable for 0.3, 1.0, 3.0, and 10 seconds. In addition, it is possible to "switch out" the time constant, in which case the time constant will be approximately 2 milliseconds.

The third stage is a buffer with unity gain for driving the output coaxial cable. The output is the opposite polarity of the input (inverted).

TYPICAL OPERATION

The SCU offers considerable flexibility of operation with a wide variety of gain settings available. There are, however, some general guidelines which should be observed for optimum operation.

1. Care should be taken in setting offsets. Presence of an offset can significantly distort the value of the ratio VAC/VDC , particularly for low values of VDC .
2. High gain settings should be used with caution, especially in the DC circuit and Stage 1 mode of operation. The user should be particularly cautious to avoid signals which drive circuits into saturation.
3. The gain and offset adjustments are not independent. After a change in gain has been made, it would be good procedure to adjust the offset of that particular stage.
4. The time constant of the signal conditioner should be set to match the time constant setting of the lock-in amplifier being used.

DC NULL ADJUSTMENTS

Use of the signal conditioner unit implies that the user is concerned about obtaining a linear DC response without offset due to dark current or operational amplifier offset. *The adjustment of these offset values is very important.* A sensitive digital DC multimeter is required for the nulling adjustments.

The DC offset circuits are not intended to balance out room light, stray light, or other non-signal light input present during the experiment. These effects are best controlled by proper experiment design, operating in a dark room, etc.

If the gain of a stage is changed, it is advisable to reset the DC null adjustment for that stage. This is particularly important for the DC output circuitry.

The AC and DC offset adjustments are multi-turn potentiometers accessible from the top of the Signal Conditioning Unit with the cover removed.

DETECTOR/PREAMPLIFIER OFFSET NULLING

For either mode of operation, it is good procedure to minimize offset from the detector. Both Hinds photodiode detector/preamplifier and photo-multiplier preamplifier have offset null adjustments.

1. Provide appropriate power to the detector/preamplifier assembly.
2. Connect the output of the detector/preamplifier directly to the input of the DC digital multimeter.
2. Block the light going to the detector and adjust the multi-turn potentiometer until the digital meter reads 0 millivolts. (This is the factory setting for all Hinds photodiode detector/preamplifiers.)

AC OFFSET NULLING

It is recommended that the AC offset be adjusted, even if the input mode of operation is being used.

1. Disconnect the input signal cable, switch the input to AC coupling and connect the multimeter to the AC output.
2. Adjust the AC offset potentiometer until the multimeter reads 0 millivolts.

INPUT MODE DC OFFSET NULLING

1. Check to make sure the jumper is in the "Input" position.
2. Connect the detector/preamplifier being used to the SCU and block the light to the detector.
3. Switch the Time Constant switch to "Out."
4. Connect the multimeter to the DC output and adjust the trimpot for a null reading (0 millivolts).

STAGE 1 MODE OFFSET NULLING

1. Follow the procedure for Input Mode DC Offset Nulling described above.
2. Switch the jumper to the "Stage 1" position inside the cabinet.
3. Set the AC gain to the value to be used during the experiment.
4. Connect the detector/preamplifier to the SCU input. Block the light to the detector.
5. The digital voltmeter should still be connected to the DC output.
6. Adjust the AC offset potentiometer for a null reading on the digital voltmeter.

USER SUPPORT INFORMATION

Hinds Instruments, Inc. makes every attempt to ensure that the Signal Conditioning Unit is a product of superior quality and workmanship. Our service personnel are available to assist you from 8:30 a.m. to 3:30 p.m. Pacific Time. Our Service Department telephone number is (503) 690-2000.

This section consists of the following items:

- A. One-Year Limited Warranty: Please read this information carefully.
- B. Return for Repair Procedure: This procedure is for your convenience in the event you must return your Signal Conditioning Unit for repair. Follow the packing instructions carefully to protect your instrument in transit.

A. Limited Warranty

Hinds Instruments, Inc. (Hinds) warrants the SCU-90 Signal Conditioning Unit to be free from defects in materials and/or workmanship when operated in accordance with the manufacturer's operating instructions for one (1) year from the date of purchase, subject to the provisions contained herein. Hinds' warranty shall extend to the original purchaser only and shall be limited to factory repair or replacement of defective parts.

Exclusions

This warranty does not cover normal maintenance, damage resulting from improper use or repair, or abuse by the user. This warranty extends only to repair or replacement, and shall in no event extend to consequential damages. In the event of user repair or replacement, this warranty shall cover neither the advisability of the repair undertaken, nor the sufficiency of the repair itself.

THIS DOCUMENT REFLECTS THE ENTIRE AND EXCLUSIVE UNDERSTANDING OF ALL THE PARTIES, AND EXCEPT AS OTHERWISE PROVIDED HEREIN, ALL OTHER WARRANTIES, EXPRESS OR IMPLIED,

PARTICULARLY THE WARRANTIES OF MERCHANTABILITY AND/OR FITNESS FOR A PARTICULAR PURPOSE, ARE EXCLUDED.

This warranty gives you specific legal rights, and you may also have other rights which vary from state to state.

B. Return for Repair Procedure

In the event of defects or damage to your unit, first call the factory Modulator Service Department. Our hours are 8:30 a.m. to 3:30 p.m. Pacific Time, Monday through Friday. Our telephone number is (503) 690-2000.

If factory service is required, return your Signal Conditioning Unit as follows:

- a. Packing
 - wrap unit in plastic bag first.
 - pack in original shipping carton or a sturdy over-sized carton.
 - use plenty of packing material.

- b. Include
 - a brief description of the problem with all known symptoms.
 - your daytime phone number.
 - your return street shipping address. (UPS will not deliver to a post office box.)

- c. Shipping
 - send freight prepaid (UPS recommended).
 - insurance is recommended. (The factory can provide the replacement value of the item being shipped.)
 - COD shipments will not be accepted.

- d. Send to:
 - Modulator Service Department
 - Hinds Instruments, Inc.
 - 3175 NW Aloclek Drive
 - Hillsboro, OR 97124

If your unit is under warranty, after repair or replacement has been completed, it will be returned by a carrier and method chosen by Hinds Instruments, Inc. to any destination within the continental United States. If you desire some specific form of conveyance or if you are located beyond these borders, then you must bear the additional cost of return shipment.

If your unit is not under warranty, we will call you with an estimate of the charges. If approved, your repaired unit will be returned after all charges, including parts, labor, and return shipping and handling, have been paid. If not approved, your unit will be returned as is via UPS COD for the amount of the UPS COD freight charges.

