

| REVISION HISTORY | | | | |
|------------------|-----|-------------|------|----------|
| ZONE | REV | DESCRIPTION | DATE | APPROVED |
| | | | | |

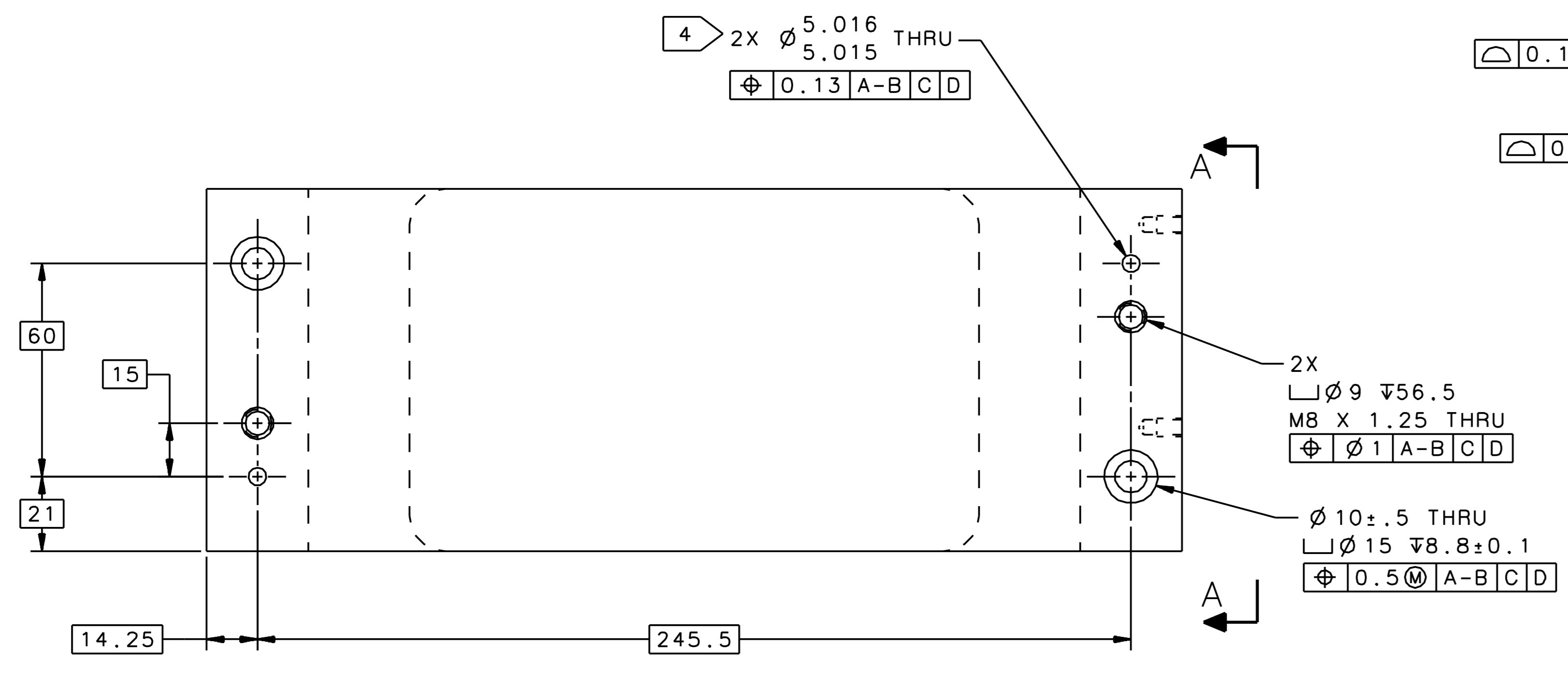

DETAIL B
TOP SIDE OF CORE HALF
HOLE LOCATIONS

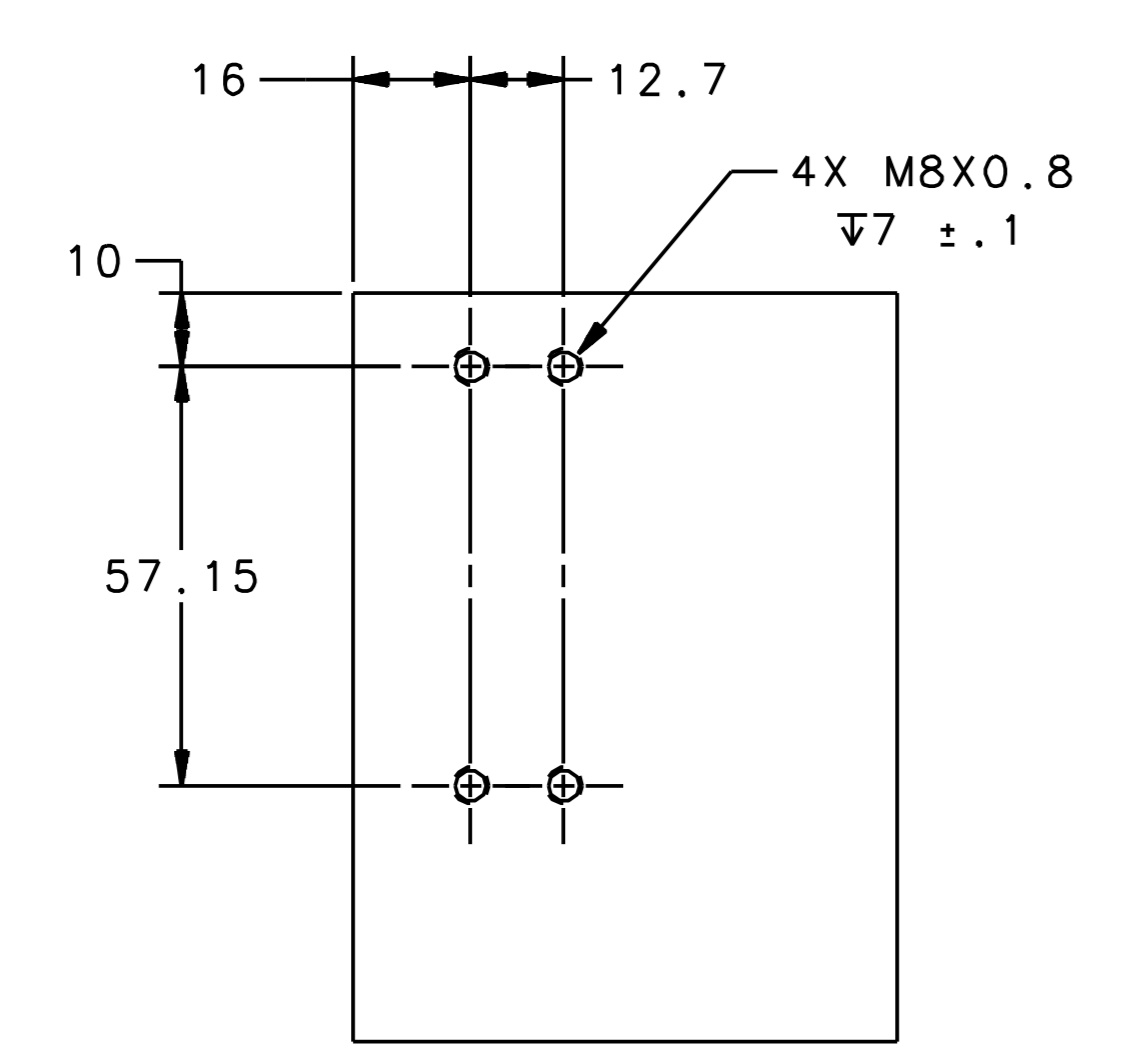

SECTION A-A
HOLES FOR TERMINAL BLOCK
(HIDDEN LINES NOT SHOWN FOR CLARITY)

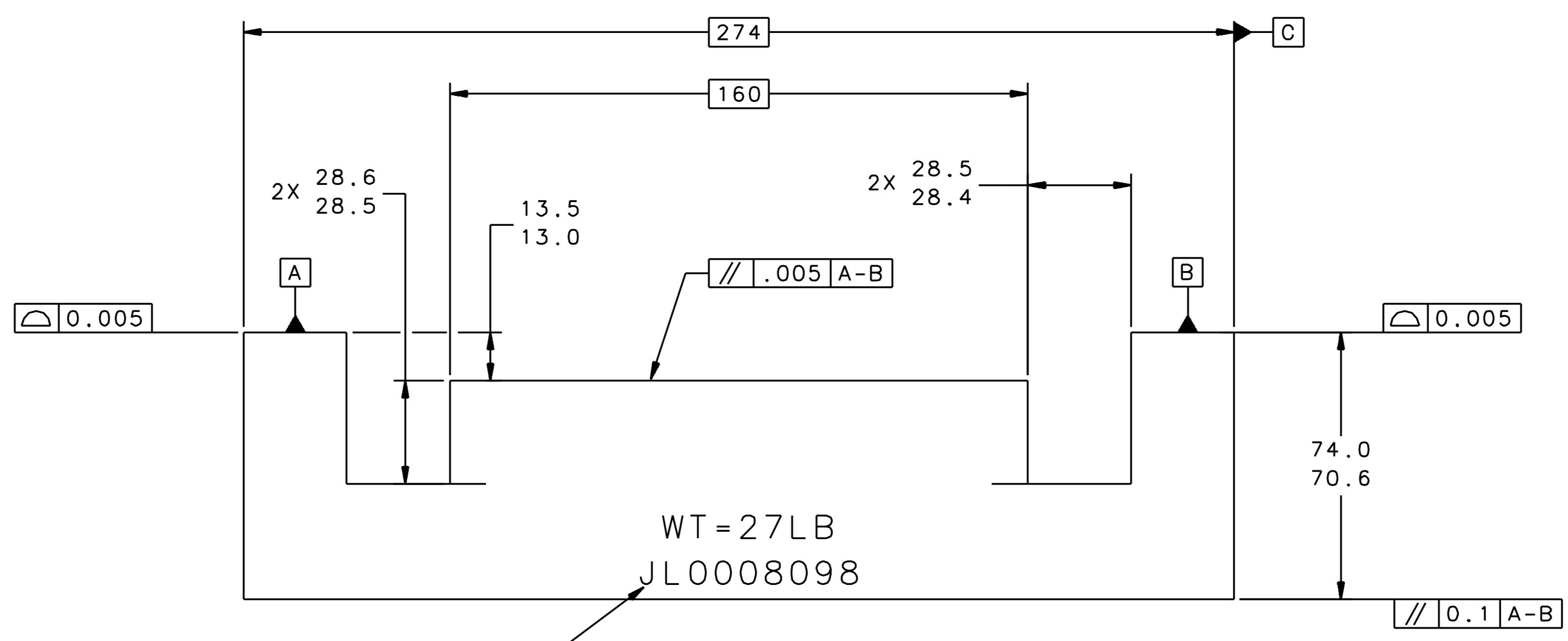
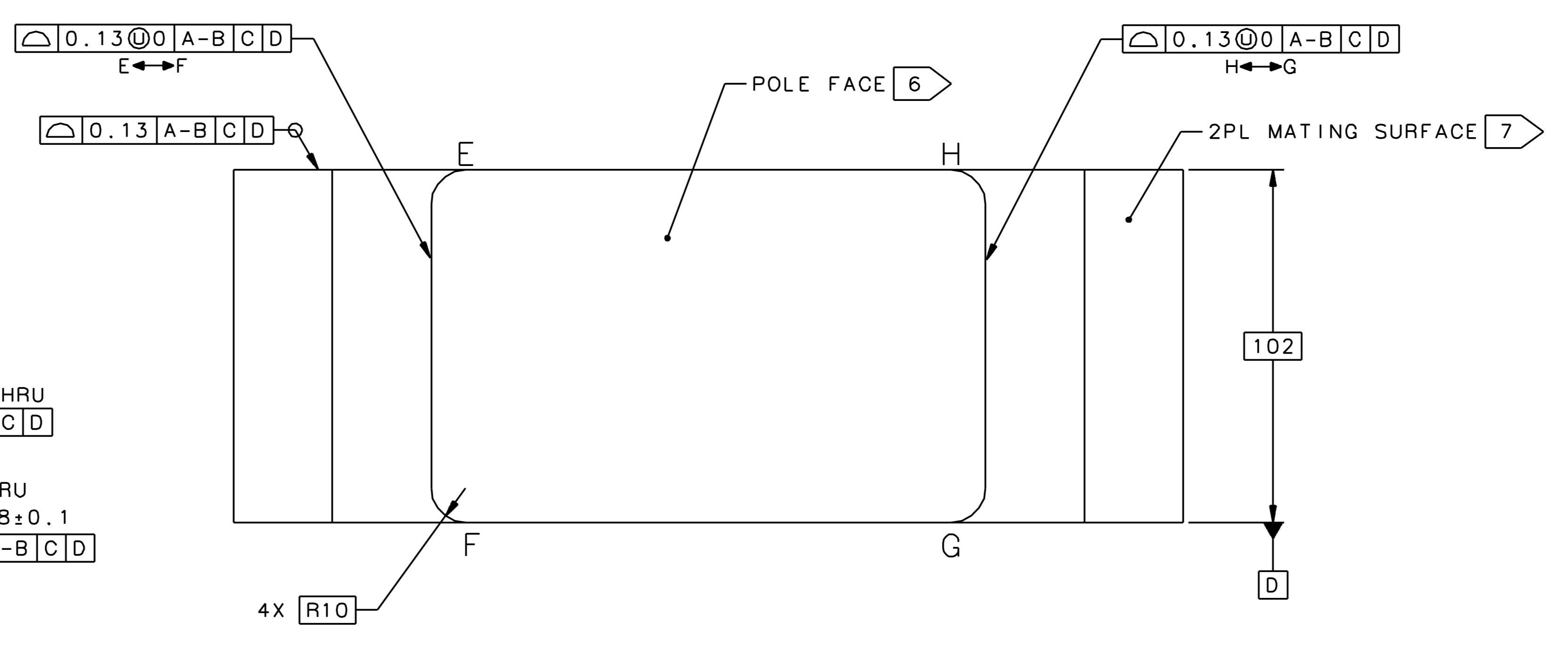

DETAIL A
MACHINING

PRELIMINARY
02-21-14
REV 03

- NOTES:**
- ASME Y14.5-2009 IS USED FOR ALL DIMENSIONING AND TOLERANCING.
 - DO NOT USE MAGNETS FOR HANDLING OR MACHINING OPERATIONS.
 - APPROXIMATE WEIGHT OF CORE STEEL IS 27 LB.
 - FEATURE REQUIRES CLAMPING TO MATING PART, JL0008736, DL MAGNET CORE - BOTTOM, PRIOR TO MACHINING.
 - USING .25IN HIGH CHARACTERS, ETCH WEIGHT AND PART NUMBER OF CORE HALF IN AREA AS INDICATED.
 - FINISH OUTER SURFACES WITH RUSTOLEUM #964402 SEMI-GLOSS SAFETY RED PAINT. FINISH POLE FACE SURFACES WITH GLOSS URETHANE VARNISH THINNER 1:1 WITH MINERAL SPIRITS, WIPED ON THEN WIPED OFF WITH A LINT FREE CLOTH.
 - APPLY LPS 3 RUST INHIBITOR TO ALL MAJOR MATING SURFACES PRIOR TO ASSEMBLY, PER MANUFACTURER'S INSTRUCTIONS.

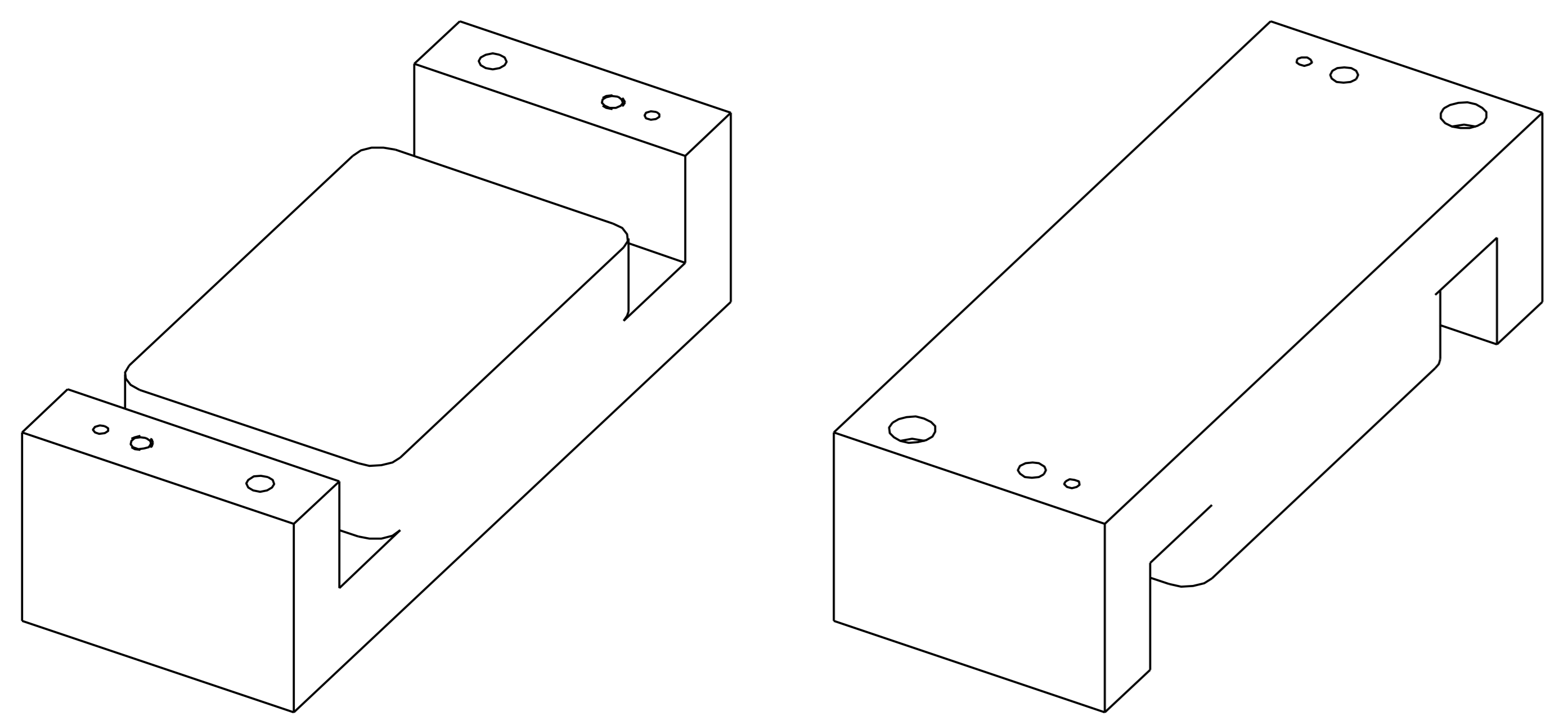

ISOMETRIC
(NOT TO SCALE)

| REV | ITEM | PART OR IDENTIFYING NO | QUANTITIES OR DESCRIPTION | MATERIAL SPECIFICATION | NOTES |
|-----|------|------------------------|---------------------------|------------------------|-------|
| | | | | | |

| | | | |
|--|--|------------------------|------|
| EACH SHEET OF MULTI-SHEET DRAWINGS SHALL ALWAYS HAVE THE SAME REVISION LEVEL. | | TRACKING NO | N/A |
| UNLESS OTHERWISE SPECIFIED, DIMENSIONS ARE IN INCHES AND DECIMAL FRACTIONS UNLESS INDICATED OTHERWISE. | | APPROVALS | DATE |
| DRAWN: S.A. GREGORY | | 13FEB14 | |
| CHECKED: | | | |
| APPROVED: | | | |
| MATERIAL: AISI 1006 STEEL | | THIRD ANGLE PROJECTION | |
| FINISH: MACHINED SURFACES UNLESS NOTED OTHERWISE. BREAK ALL SHARP EDGES. | | DO NOT SCALE DRAWING | |

| | | |
|------------------------------------|---|--------------------------|
| UNITED STATES DEPARTMENT OF ENERGY | Jefferson Lab Thomas Jefferson National Accelerator Facility | Neopoli News Virginia |
| MAC CORRECTOR DL | | |
| DL MAGNET CORE - TOP | | |
| JL0008098 | | |
| SCALE: 1:1 | 160 000 00 | JL0008102 SHEET 1 OF 1 |