

MOLLER New IA HV Driver – Requirement Document

Paul King, Caryn Palatchi, Kent Paschke, Riad Suleiman

October 26, 2023

To make sure the electron charges in every helicity window are equal, an active charge feedback is used during the Hall physics experiment. Typically, the charge asymmetry is measured in the Hall over a few minutes, then an optical element on the laser table is changed to zero the charge asymmetry by reducing the laser light in the helicity windows that have more electron charge. The Intensity Attenuator (IA) system is design to do this. Each hall has such a system in its laser path on the laser table. A schematic is shown in Figure 1.

The IA system uses the real-time helicity signal and thus it is very important to make sure any information that gives the real-time helicity is isolated from the outside world. The leakage of the real-time helicity signal (e.g., changing the electrical ground level) can be picked up by other devices used by data acquisition or in control of the electron beam, and can therefore create an instrumental signal that mimics and confounds the measurement of parity-violation.

IA System

The IA system for Hall A is shown in Figure 2. Hall B and C systems are identical. A new system will be installed for Hall D. The voltage on the Pockels Cell changes between 0 V for one helicity and setpoint voltage (-45 V to +45 V) for the other helicity window as shown in Figure 3. This changes the shape and orientation of elliptically polarized light after the cell. The Linear Polarizer (LP) then removes more or less light from the laser. Note that the IA system is designed to remove light from both helicities. This is done by having a $\lambda/2$ wave plate (WP) as part of the system. The angle (about 3°) of this wave plate relative to the direction of the linear polarization of the incident laser light determines the amount of laser light removed (around 10%) and thus the sensitivity of the system (slope in ppm/V or part-per-million per volt).

The Pockels cell voltage has to change between the two helicities within $\sim 10 \mu\text{s}$.

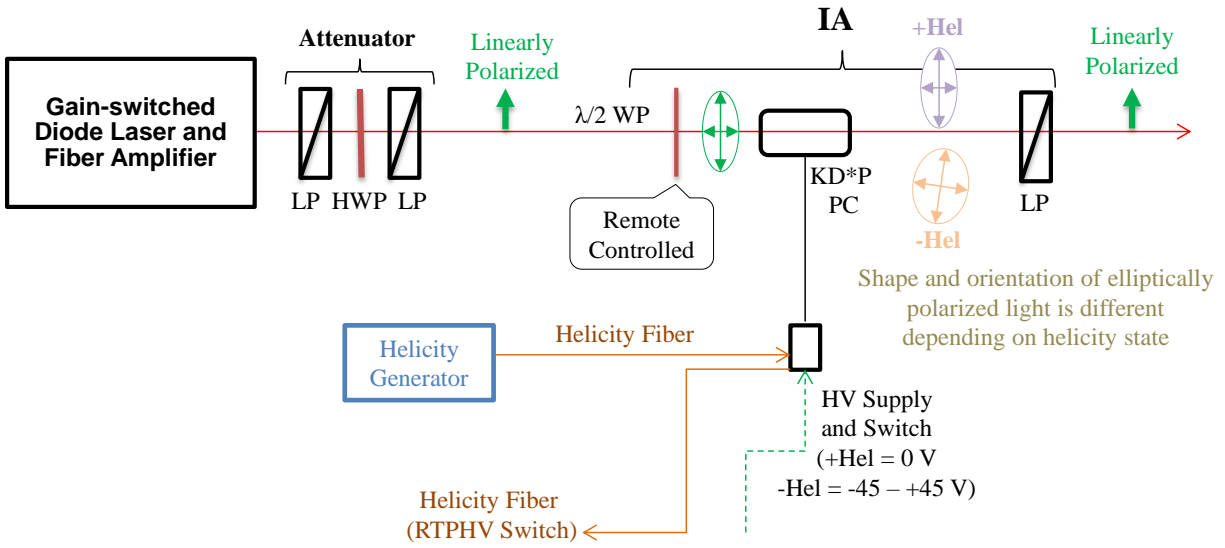

Figure 1: The IA system to perform charge feedback for the experimental Hall.

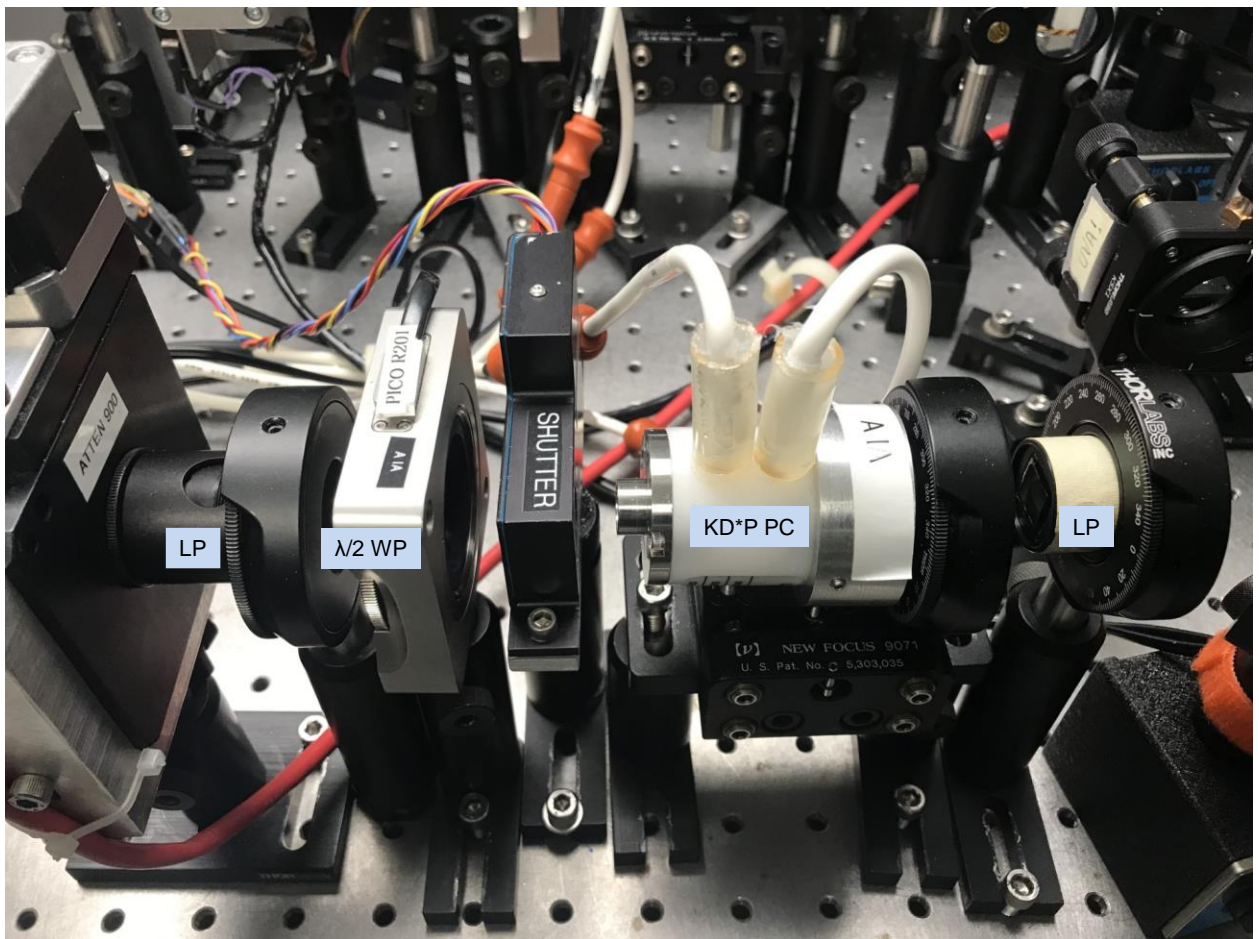

Figure 2: The RTP Pockels cell installed at CEBAF laser table with its HV connections.

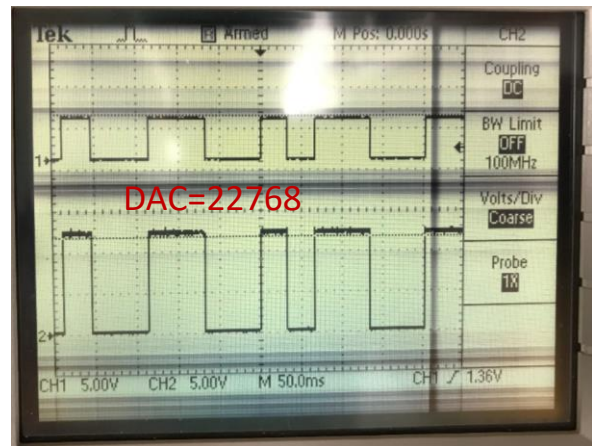
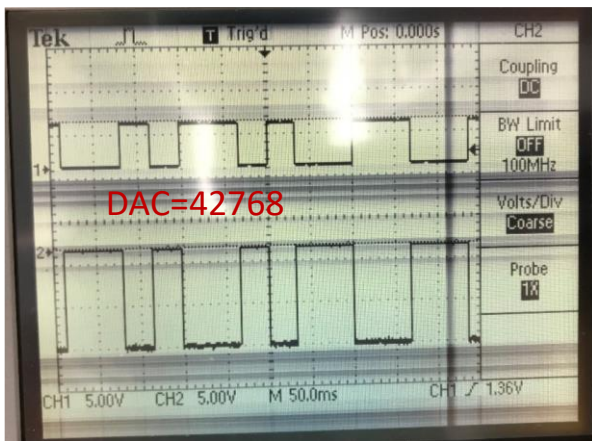
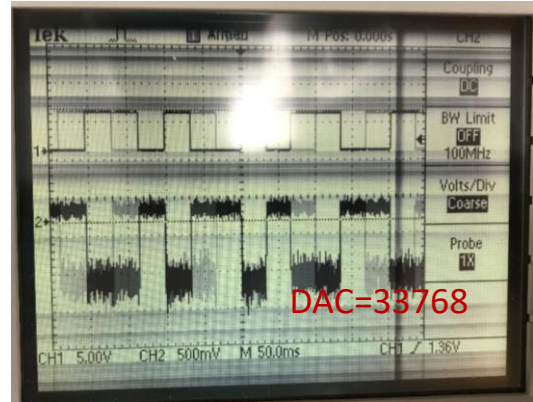
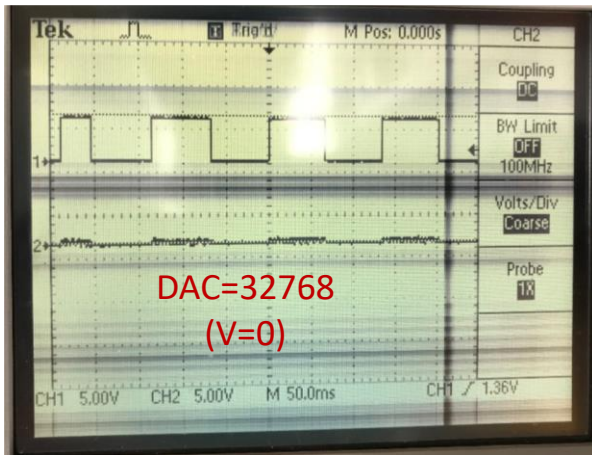

Figure 3: Real-time helicity (CH1) signal and Hall A IA voltage (CH2).

Functional requirements for HV Driver

The HV driver will consist of 4 independently controlled HV supplies, and 4 switches each toggling between HV supplies and isolated ground.

Electrical Isolation Great care is required to maintain security of the real-time helicity signal. Both the HV switch and the HV supply should be electrically isolated in the same manner as the RTP HV driver system. An isolated ground should be used to connect to the ground of the IA Pockels Cell.

Disabled State The driver should have an OFF state in which the driver does not process the real-time helicity signal (or, process only in an entirely electrically isolated system). In this state, the electrode voltages should ideally match ground. In any case, no switching should occur.

Physical Characteristics The switch should be small and conveniently connectorized to allow location near to the Pockels cell on the laser table (< 10" HV cabling between switch and cell). The switch should not require forced air cooling or otherwise create a source of vibration on the table.

Control systems and protections

1. Control system: the real-time helicity signal should be accepted on either optical fiber or TTL signal. Any TTL copies of real-time helicity signals should be driven only with complementary signals (this is likely part of any design using complementary switching, but also the complementary TTL signals reduce pickup of the signals).
2. Protection: The switch should not allow a short between opposite polarity HV supplies. It should hold off the applied voltage with minimal leakage current.
3. No DC operation: The switch should return each electrode voltage to ground (within <20 V or so) if the real-time helicity is removed or does not transition. A reasonable time threshold might be within about 1 s – 15 s. The switch should return to operation when the real-time helicity signal resumes operation.
4. Operation warning: A warning signal should be raised if the switch is deactivated by a removed or unchanging real-time helicity signal.
5. HV supply warning: A warning should also be raised if any voltage drops to zero, or a monitor of the voltage and/or average current should be available. This monitor should not compromise the ground isolation.

Transitions The transitions should be triggered by the real-time helicity signal, with all electrodes switching together to toggle between the two Pockels cell states.

1. Fast HV Switching: The driver should be able to change HV setpoints at 2 kHz.
2. Rise time: The transition should be completed and stable (within ~10% of the final set value) within about 10 μ s, including any lag time after arrival of the real-time helicity.
3. Stability: the HV value over the time window (as slow as 240 Hz, as fast as 2 kHz) should be stable within about 10% of the set point.
4. Symmetry: the transition between the two states should be as symmetric as possible, with regards to lag time, signal rise-time, total transition time, and stability after transition.
5. Limit on piezoelectric ringing: The piezo-electric ringing of the crystal upon being driven by the system at maximum voltage should have a ringing amplitude of <10% (as observed on a scope signal).

HV Supply

1. Dynamic range: Each HV output should span at +/-100 V.
2. Stability: The applied HV at a given setpoint should be stable within 10% at time scales of 1 week or more.
3. Control system precision: Each HV voltage should be controlled by a DAC with 16 or 18-bit resolution, for bit resolution of at least 0.01 V.

Characterization The switch must be tested under load and measured using the optical properties of the Pockels cell.

Existing HV Drivers

1. Existing IA HV driver has only 3 HV outputs to Halls A, B, and C. See Figure 4.
2. In addition to the real-time helicity fiber, the existing IA driver receives another two fibers from the Helicity Generator Board:
 - a. IA0: This is an IA Control signal that indicates the current pattern.
 - b. IA1: This is an IA Control signal that indicates the previous pattern.

Both of these two fibers will not be used in the new IA HV driver.



Figure 2: IA system HV supply and switch.