

PQB Requirements at JLEIC

April 13, 2017

Parity Violation

Particle	Electric Charge	Weak Charge	
		Right-handed	Left-handed
e	-1	0	$-\frac{1}{2}$
Up quark	$+\frac{2}{3}$	0	
Down quark	$-\frac{1}{3}$	0	
proton	+1	0	$1-4\sin^2\theta_W (=0.08)$
Neutron	0	0	1

- Electromagnetic (EM) interaction is same for Right-handed and Left-handed electrons (Parity is conserved)
- Weak interaction is different for Right-handed and Left-handed electrons: Left-handed electrons interact weakly but Right-handed do not (Parity is violated)

Parity Reversal

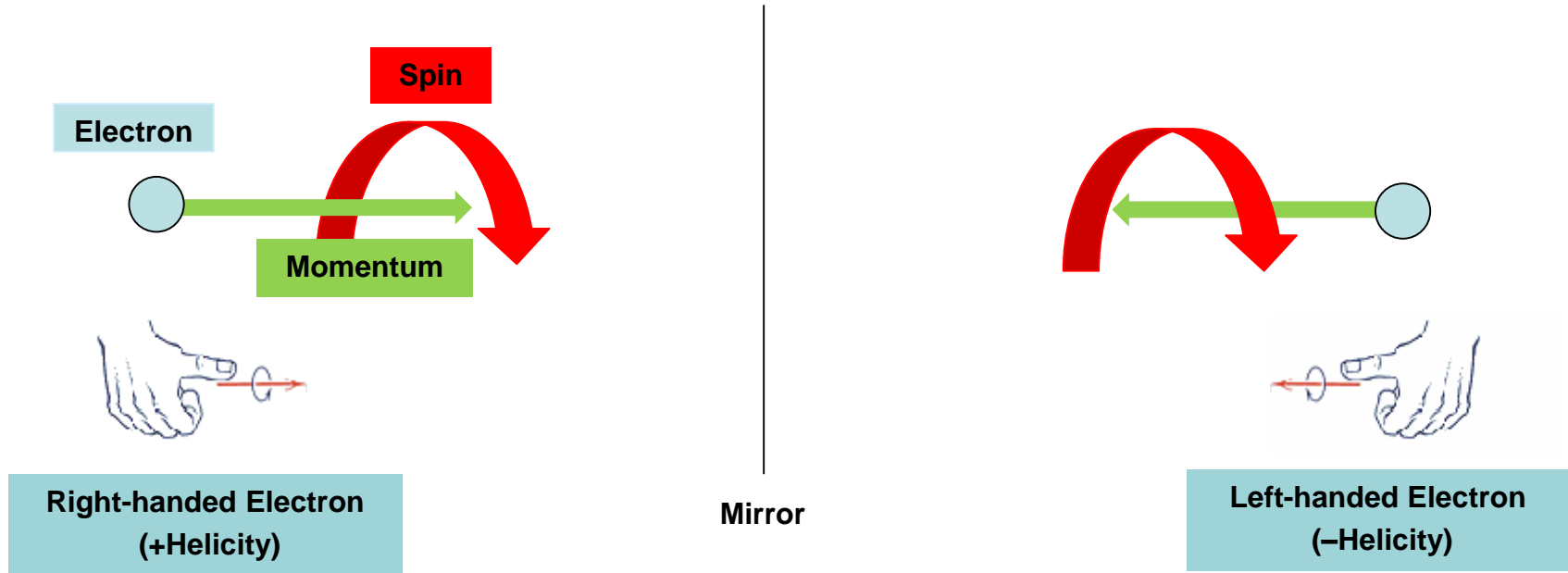

- Under Parity Reversal, Right-handed electron becomes Left-handed electron (Helicity Reversal)
 - Changing electron's spin direction (Helicity Reversal) is equivalent to Parity Reversal

Experimental Techniques

➤ How to carry out a parity violation (PV) experiment:

- Scatter longitudinally polarized electrons off un-polarized target (*i.e.*, hydrogen, deuterium, helium, lead)
- Reverse beam helicity (\pm) with Pockels Cell, measure detected signals (D^\pm) and currents (I^\pm) per helicity, then calculate physics asymmetry (A_{physics}):

$$A_{\text{physics}} = \frac{\frac{D^+}{I^+} - \frac{D^-}{I^-}}{\frac{D^+}{I^-} + \frac{D^-}{I^+}} \approx \frac{\text{Weak}}{\text{EM}}$$

1/15th of a second

- Repeat millions of measurements
- Statistical distribution of these measurements is Gaussian: Mean is average asymmetry and error is width of Gaussian divided by square root of number of asymmetry measurements
- Average asymmetry is very small (1 – 50 ppm)

Pockels Cell

- Pockels Cell is voltage controlled quarter wave plate
- Changes polarization of laser from linearly-polarized light to circularly polarized light

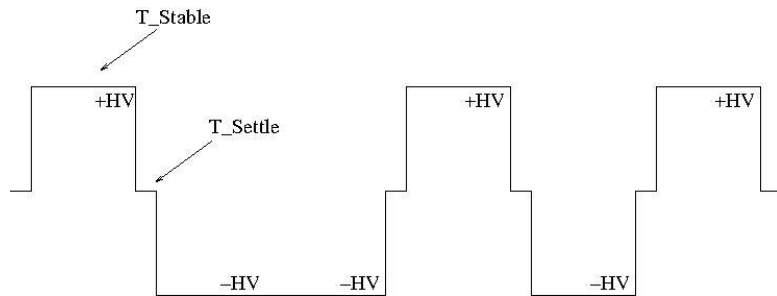
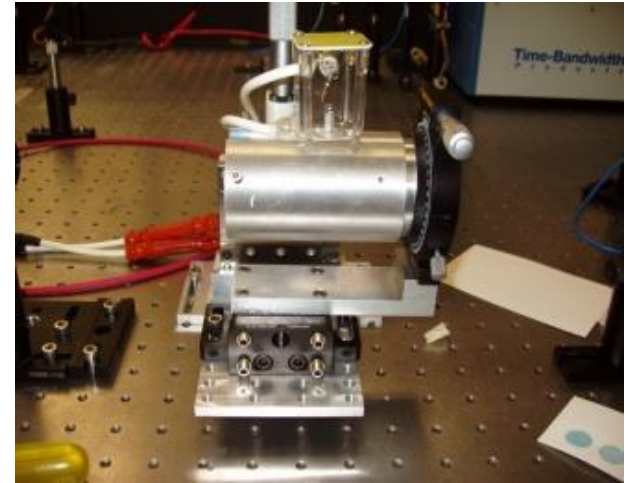
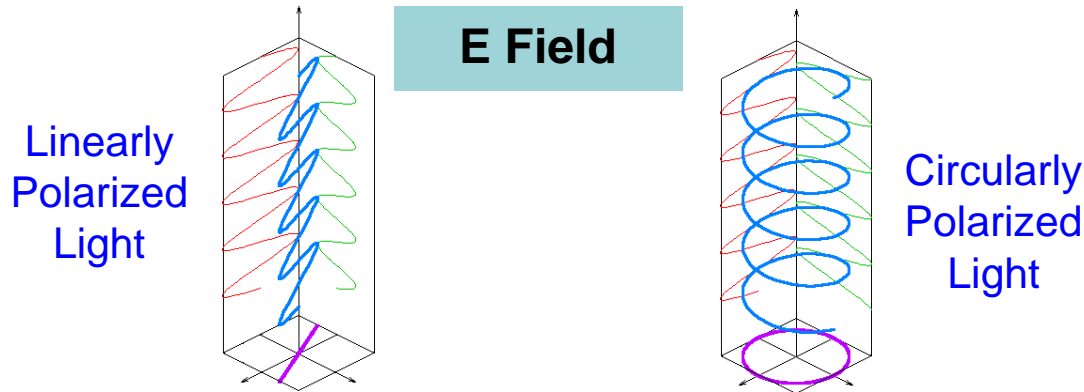

Pockels Cell HV

+HV: Right-handed circularly polarized light
→ +Helicity electron

-HV: Left-handed circularly polarized light
→ -Helicity electron

Helicity Correlated Beam Properties

- Charge Asymmetry: when average current of electron beam corresponding to one helicity state is different from other state,

$$A_I = \frac{I^+ - I^-}{I^+ + I^-}$$

- ✓ Effect of charge asymmetry is determined by experimental non-linearities (~few percent)
- ✓ We measure charge asymmetry of order 1 – 50 ppm

- Position Difference: when average position of electron beam corresponding to one helicity state is different from other state,

$$\Delta x = x^+ - x^-$$
$$\Delta y = y^+ - y^-$$

- ✓ Effect of position differences is determined by scattering cross section sensitivities
- ✓ We measure position differences of order 1 – 40 nm

- Polarization difference between two helicities, $\Delta P = P^+ - P^-$:

- ✓ Effect of polarization differences is a systematic uncertainty of $\Delta P/P$
- ✓ We measure polarization differences of order <1%

PQB Requirements at CEBAF

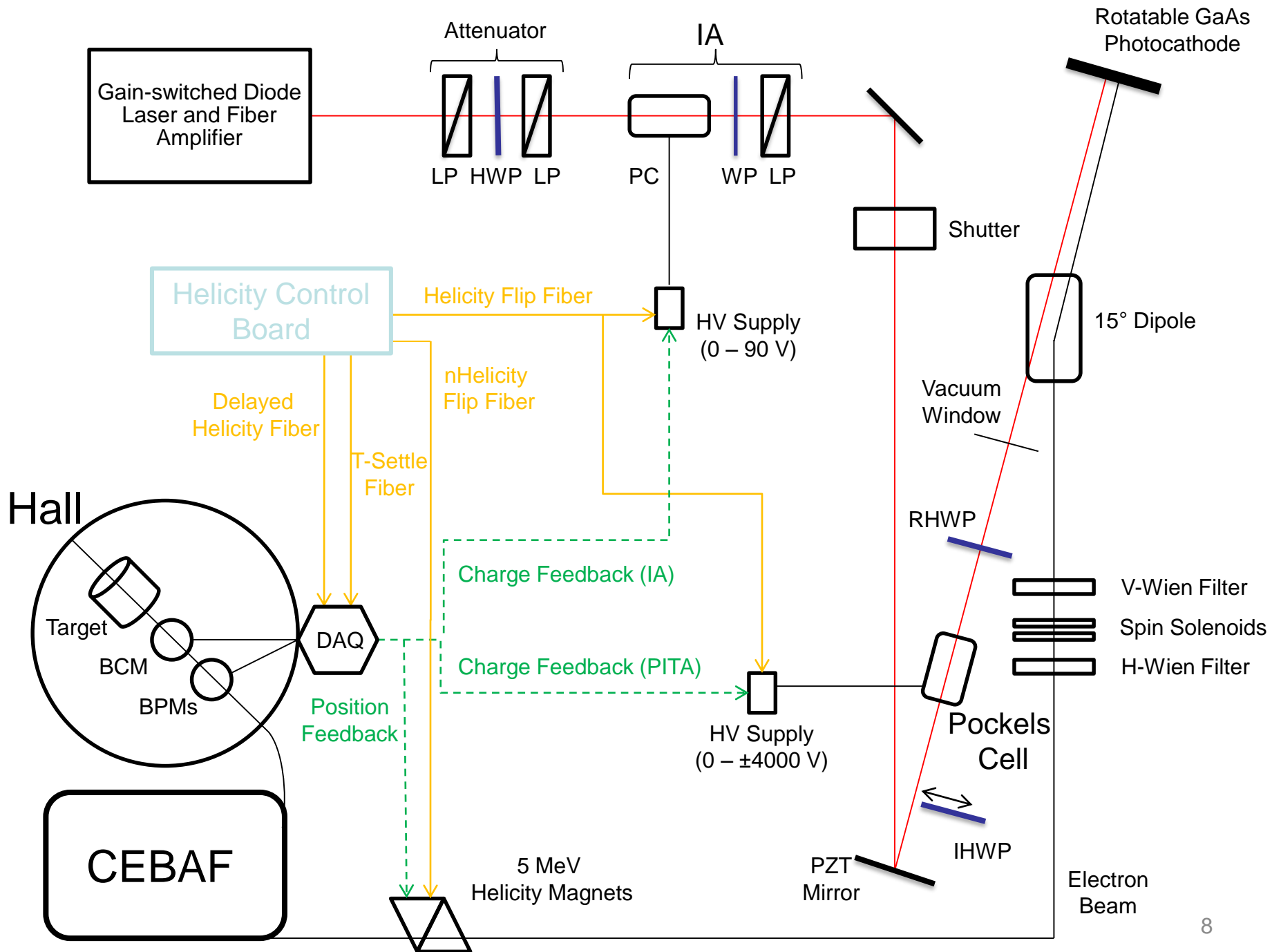

Experiment	Energy (GeV)	Pol (%)	I (μA)	Target	A_{pv} (ppb)	Charge Asym (ppb)	Position Diff (nm)	Angle Diff (nrad)	Size Diff ($\delta\sigma/\sigma$)
HAPPEX-I (Achieved)	3.3	38.8 68.8	100 40	^1H (15 cm)	15,050	200	12	3	
G0-Forward (Achieved)	3.0	73.7	40	^1H (20 cm)	3,000- 40,000	300 ± 300	7 ± 4	3 ± 1	
HAPPEX-II (Achieved)	3.0	87.1	55	^1H (20 cm)	1,580	400	2	0.2	
HAPPEX-III (Achieved)	3.484	89.4	100	^1H (25 cm)	23,800	200 ± 10	3	0.5 ± 0.1	10^{-3}
PREx-I (Achieved)	1.056	89.2	70	^{208}Pb (0.5 mm)	657 ± 60	85 ± 1	4	1	10^{-4}
QWeak-I (Achieved)	1.155	89.0	180	^1H (35 cm)	281 ± 46	8 ± 15	5 ± 1	0.1 ± 0.02	10^{-4}
QWeak	1.162	90	180	^1H (35 cm)	234 ± 5	$<100\pm 10$	$<2\pm 1$	$<30\pm 3$	$<10^{-4}$
PREx-II	1.0	90	70	^{208}Pb (0.5mm)	500 ± 15	$<100\pm 10$	$<1\pm 1$	$<0.3\pm 0.1$	$<10^{-4}$
MOLLER	11.0	90	85	^1H (150 cm)	35.6 ± 0.74	$<10\pm 10$	$<0.5\pm 0.5$	$<0.05\pm 0.05$	$<10^{-4}$

PQB Requirements at JLEIC

JLEIC

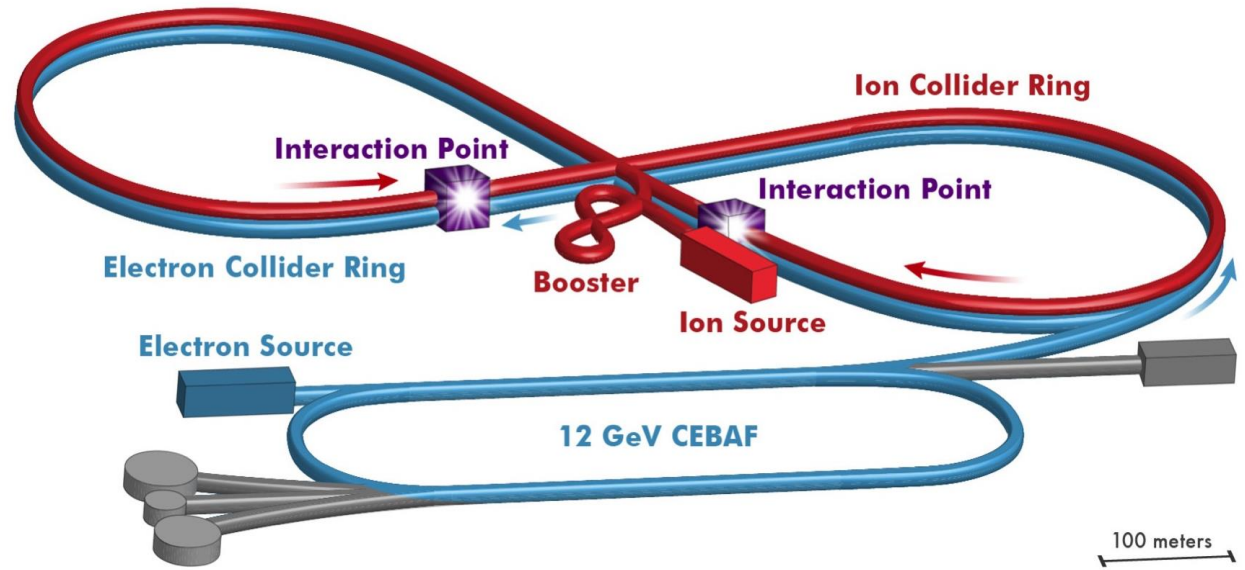

JLEIC Polarized Source

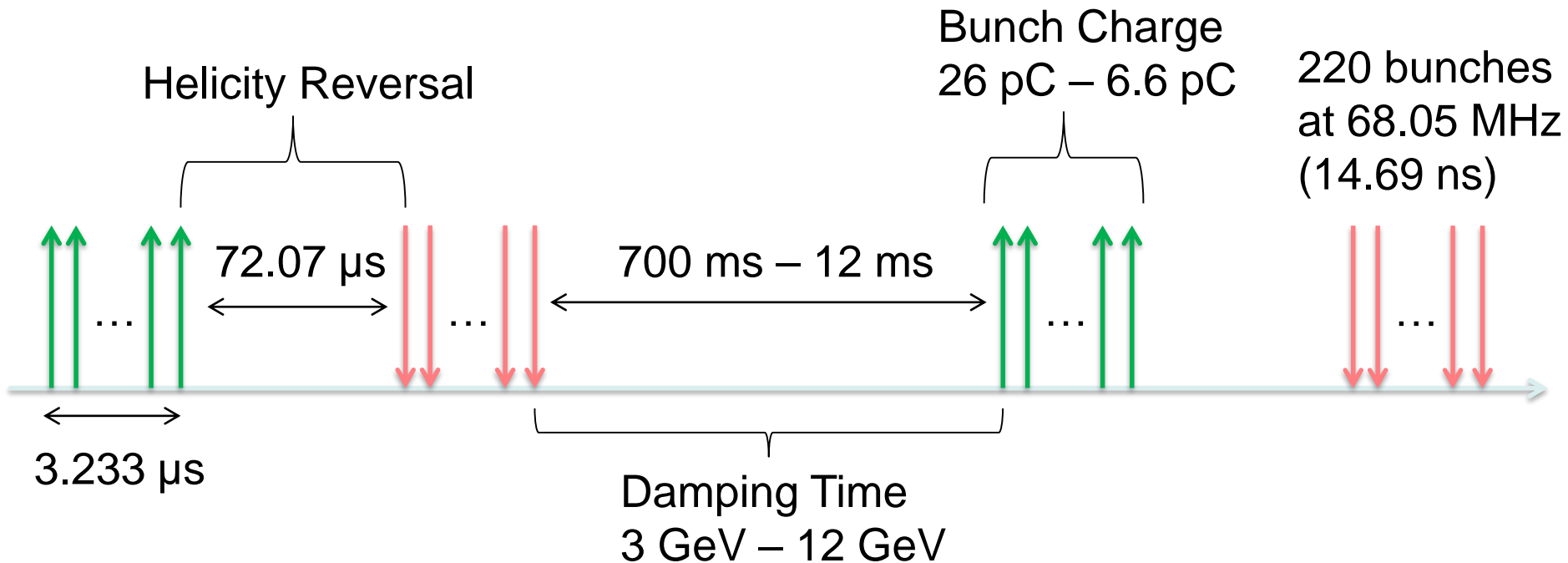

- Pockels cell switching time at CEBAF today $\sim 70 \mu\text{s}$. Planned for Moller Exp. $\sim 10 \mu\text{s}$
- Source rate of 68.05 MHz is $1/7^{\text{th}}$ Collider collision rate of 476.3 MHz (PEP-II cavities)
- Harmonic number of ring is 3416 and revolution time is $7.17 \mu\text{s}$
- Half ring is filled with one helicity (1540 bunches – $3.233 \mu\text{s}$) and second half is filled with opposite helicity (1540 bunches – $3.233 \mu\text{s}$)
- Two gaps between two helicities (each $0.353 \mu\text{s}$) allow for beam abort, ion cleaning, turning on/off injection kicker, and detector readout
- Injection cycles repeat until ring is filled to required current

Time Structure of Polarized e⁻ Injection

Mid-cycle 1, inject the 1st of every 7 buckets in the ring

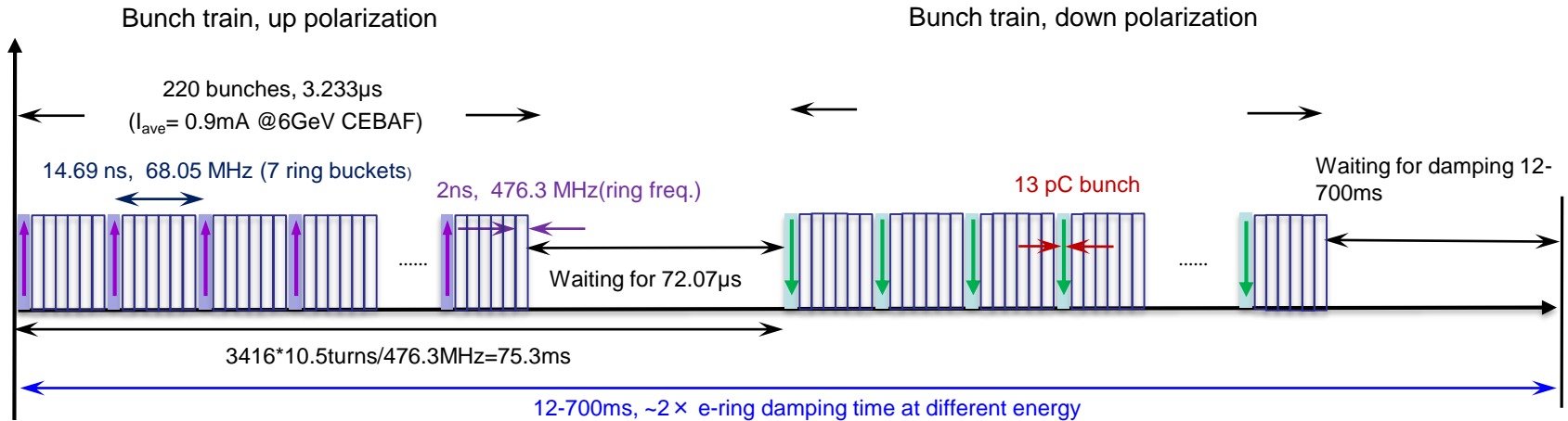

Note that:

- An average injected beam current of tens-of-nA level (same as or lower than initial injection beam current) can maintain a high equilibrium polarization in whole energy range
- Same time structure of polarized electron injection can be applied to both initial and top-off injections at a certain energy, but charge per bunch may/can vary

	Unit	Energy		
	GeV	3	6	10
Charge per bunch	pC	26	13	8
Peak current (CW)	mA	1.8	0.9	0.55
Pulse current	μA	0.015	0.035	0.175
Injection time	min.	23	10	0.5

Polarized ions, non-polarized Electrons?

- Physics asymmetry is comparable: $A_{\vec{e}+d} \sim A_{e+\vec{d}}$
- Access different combination of weak neutral-current coupling constants
- Can fill ion ring with two helicities or one helicity – may use weak solenoid to flip helicity. With one ion helicity, this solenoid maybe used to generate random flipping and delayed reporting.
- Ion Ring has 1 ms to 0.1 sec spin flipping with weak solenoid

Collider Ring Issues

- Helicity stable time is $3.233 \mu\text{s}$ and detector readout time is $0.353 \mu\text{s}$ – for CEBAF, helicity stable time is 1 ms to 33 ms and detector readout time is $70 \mu\text{s}$
- Electron-ion bunches collides for many hours before bunches are aborted and fresh ones are injected in rings
- Continuous top-off injections will be used to apply charge feedback to zero charge asymmetry
- Gear switching, where number of ion bunches is different than electron punches, is necessary – each electron bunch will interact with all ion bunches instead of one electron bunch interacts with same ion bunch all times
- No random helicity flipping or delayed helicity reporting from Pockels Cell
- We asked CASA to consider spin flipping in the electron ring similar to the ion ring

Example

- Assume $A_{\text{physics}} = 100$ ppm
- Charge asymmetry of 1% and detector non-linearities of 2%
 - Error on asymmetry is 200 ppm → must implement charge feedback
- If the ring is filled with one helicity – flipping of helicity is done with a solenoid, then the charge asymmetry can be very small
- $P^+ = 80\%$ and $P^- = 70\%$
 - Error on asymmetry is about 13 ppm, no need for polarization feedback.
- Again, with one helicity in the ring, polarization differences and depolarization can be kept very small

Summary

- Measure charge and polarization per helicity window in Collider Ring – do not assume polarization is equal for two helicities, may have different depolarization for two helicities
- Gear Switching is very important for parity violation experiments – eliminate requirement on “helicity” correlated properties of ion beam
- Measurement of parity violation asymmetry in Collider Ring is limited by:
 - I. Statistical Errors: $\delta A \sim 1/\sqrt{L}$ where $L = 10^{34} \text{ cm}^{-2} \text{ s}^{-1}$ (compared to 10^{39} at CEBAF)
 - II. Systematic Errors: due mainly to electronics cross talk since helicities must be known in real time – no random helicity flipping or delayed helicity reporting
- Expect to measure parity violation asymmetries in Collider Ring to systematic errors of about ? ppm – compared to CEBAF systematics of about 0.01 ppm, dominated by beam polarization uncertainty.
- **Parity violation experiment in a collider ring has never been done before**

APPENDIX I: Report of the Community Review of EIC Accelerator R&D

G. Injectors

- Discussion :

For the JLEIC, the injector (CEBAF) is used to fill trains of bunches spaced by 7 buckets, and it will take many fill cycles to stack the beam current in the electron ring. It is unclear whether this injection scheme is compatible for the top-off injection (to mitigate electron beam depolarization at a higher energy) for parity-violation experiments in which bunch trains with opposite polarizations should have very similar degrees of polarization.

- Risk :

There is certain risk that the JLEIC top-off injection may not be compatible with parity-violation experiments at high electron energies. This may limit these experiments to lower center of mass energies.

- Recommendations :

For both JLEIC and the BNL RR concepts, the injection schemes should be thoroughly studied to understand their impact on physics programs.

K. Polarization Manipulation

- Discussion :

Observation: for parity violation experiments, sub-trains of bunches with opposing polarizations will be filled in the figure-8 electron ring. At high energies, the depolarization effects due to the main dipole field (when the electron polarization is in parallel with the dipole field in one of the two loops in the figure-8) are significant. As a benefit of the figure-8 configuration, this depolarization effect can be made to be the same/similar for two sets of electron bunches with opposite polarizations using a set of properly arranged spin rotators as proposed, which can help significantly reduce the polarization dependent systematic errors in experiments. Continuous top-off injection at higher energy may be needed to maintain a high degree of polarization. It is unclear how this nice feature (the same depolarization effects for bunches with opposite polarizations) can be preserved in the top-off injection scenario.

- Risk :

In both ring-ring designs (JLEIC and BNL RR), the depolarization effects at high electron energy (therefore, a high cm collision energy) can have a significant impact on parity violation experiments which demand very high degrees of consistency of polarizations of the bunches with opposite polarizations. It is important to first obtain the requirements from nuclear physicists, and then develop suitable injection and operational schemes.

- Recommendations :

Parity violation experiments place the most stringent requirements on the polarization control. The nuclear physics community should identify the related experimental needs as soon as possible to inform the accelerator designers so that appropriate solutions can be devised.

APPENDIX II: Electronic Cross-talk & Ground Loop Elimination in CEBAF Injector

Electronic Cross-talk & Ground Loop Elimination in Injector

- VME Crate of Helicity Control Board is floating and powered with isolation transformer.
- Helicity Board generates two real time helicity signals: Helicity Flip and nHelicity Flip. Current drawn by board does not depend on helicity state.
- Helicity signal is generated by pseudo-random bit generator. No correlation between helicity signal and any other signal in Accelerator or in Hall.
- Outside world receives only Delayed Helicity signal. This signal tells what helicity was in the past so there is no knowledge of real time helicity.
- Helicity Magnets VME Crate which receives one of the two real time helicity signals (nHelicity Flip) is also floating and powered by isolation transformer.
- Real time helicity signal (Helicity Flip) that goes to Laser Hut is isolated. All electronics that can see real time helicity are floating (next slide).
- All helicity-correlated beam asymmetries (position, angle, charge, energy, and size – and thus beam scraping) are minimized so helicity is the only real time property of beam that is changing.
- Programming of voltage setpoints of Pockels Cell and IA's (both receive Helicity Flip signal) in Laser Hut passes through galvanic isolation card and there are no readbacks of these voltages.

Normal Grounded VME CRATE

(slow status and control - nothing occurs at helicity flip rate)

16 bit DAC: Pockels Cell (PC) \pm HV setpoints (0 – \pm 4000 V)

16 bit DAC: Hall A, B, C Intensity Attenuator (IA) HV setpoints

RS-232: Rotating half-wave plate (RHWP) and laser attenuators

Discrete Digital I/O: Insertable half-wave plate (IHWP)

FLOATING VME CRATE

Helicity Control Board

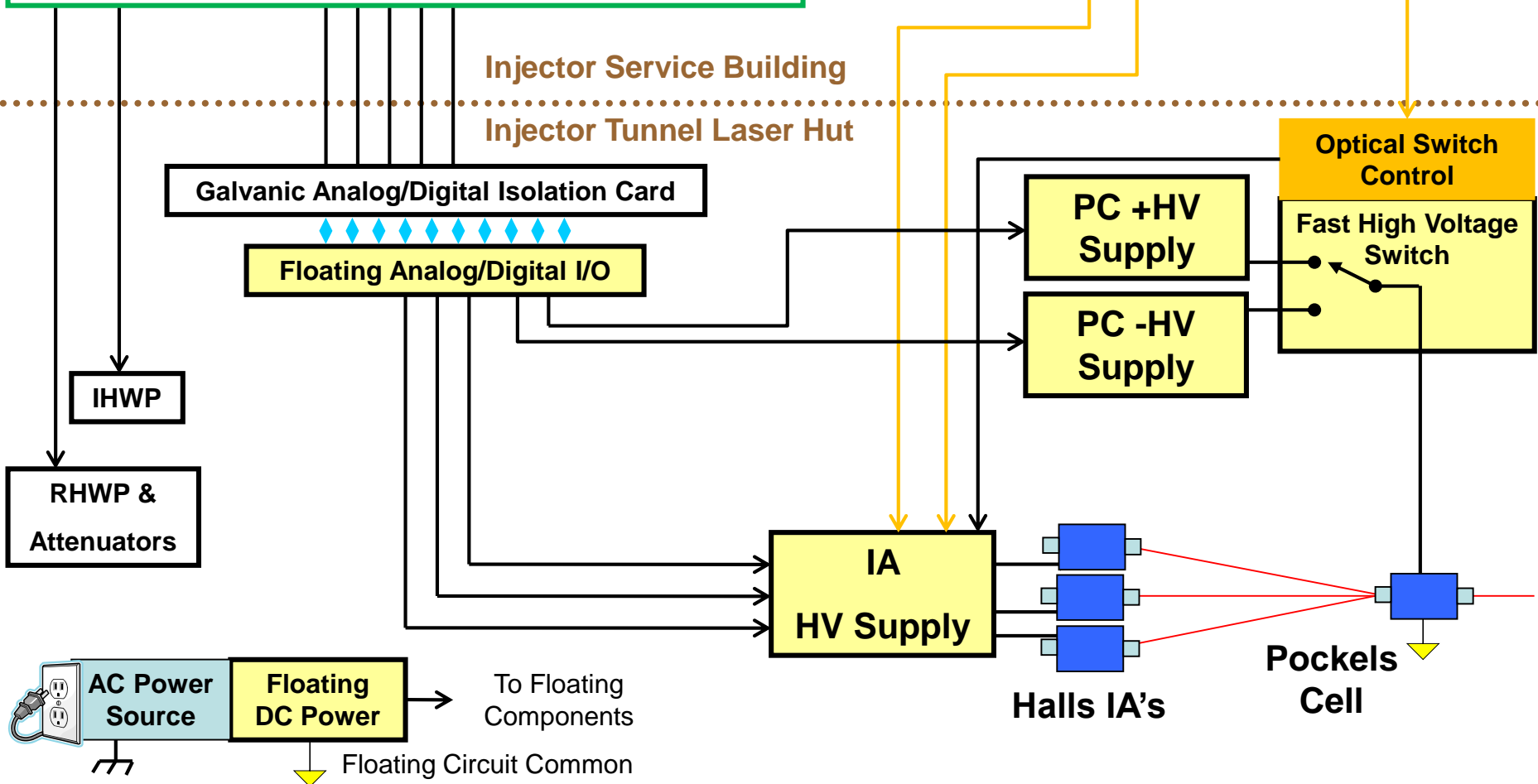

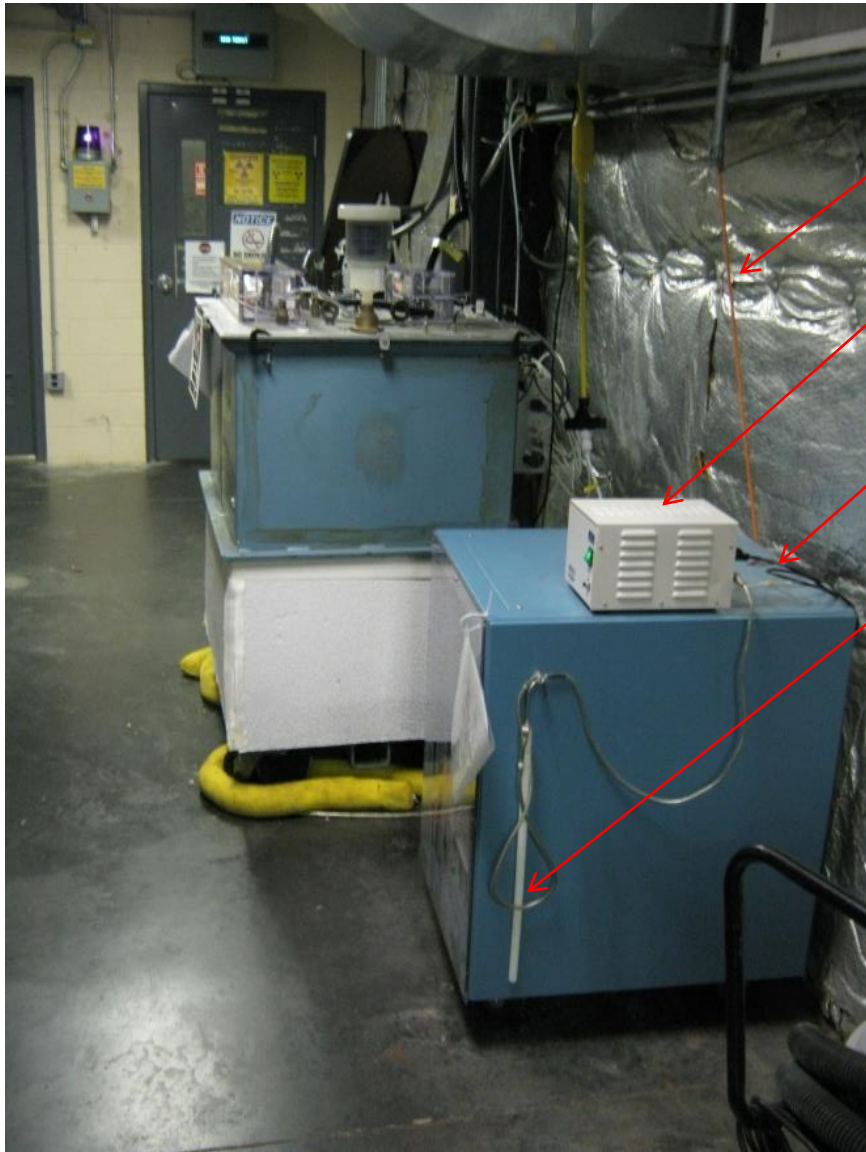

Fiber Cable

Isolation Transformer

Power Cable with Ground Pin Cut

Ground Rod

Floating VME Crate



