

Magnetized Beam Update (LDRD)

JLEIC Collaboration Meeting
March 29, 2016

Riad Suleiman and Matt Poelker

Outline

- Magnetized Bunched Electron Beam Requirements
- Magnetized Sources
- JLEIC Magnetized Beam LDRD
- Experimental Overview
- Progress
- Milestones

Magnetized Bunched Electron Beam Requirements

Bunch length	60 ps (2 cm)
Repetition rate	476.3 MHz
Bunch charge	420 pC
Peak current	7.0 A
Average current	200 mA
Transverse normalized emittance	10s microns
Cathode spot radius – top-hat (a_0)	4.4 mm
Solenoid field at cathode (B_z)	2 kG

Magnetized Sources

1. Fermilab Photoinjector Laboratory:

- Pulsed NCRF gun
- Cs₂Te photocathode and UV laser ($\lambda=263$ nm)
- Bunch charge: 0.5 nC and bunch length: 3 ps
- 0.5% duty factor (average current: 7.5 μ A)
 - Bunch frequency: 3 MHz
 - Macropulse duration: 1 ms
 - Number of bunches per macropulse: 3000
 - Macropulse frequency: 5 Hz

➤ No CW beam at high average current

2. Magnetized beam R&D at University Mainz just started

JLEIC Magnetized Beam LDRD

- Generate magnetized electron beam and measure its properties
- Explore impact of cathode solenoid on photogun operation
- Simulations and measurements will provide insights on ways to optimize JLEIC electron cooler and help design appropriate source
- JLab will have direct experience magnetizing high current electron beam

Experimental Overview

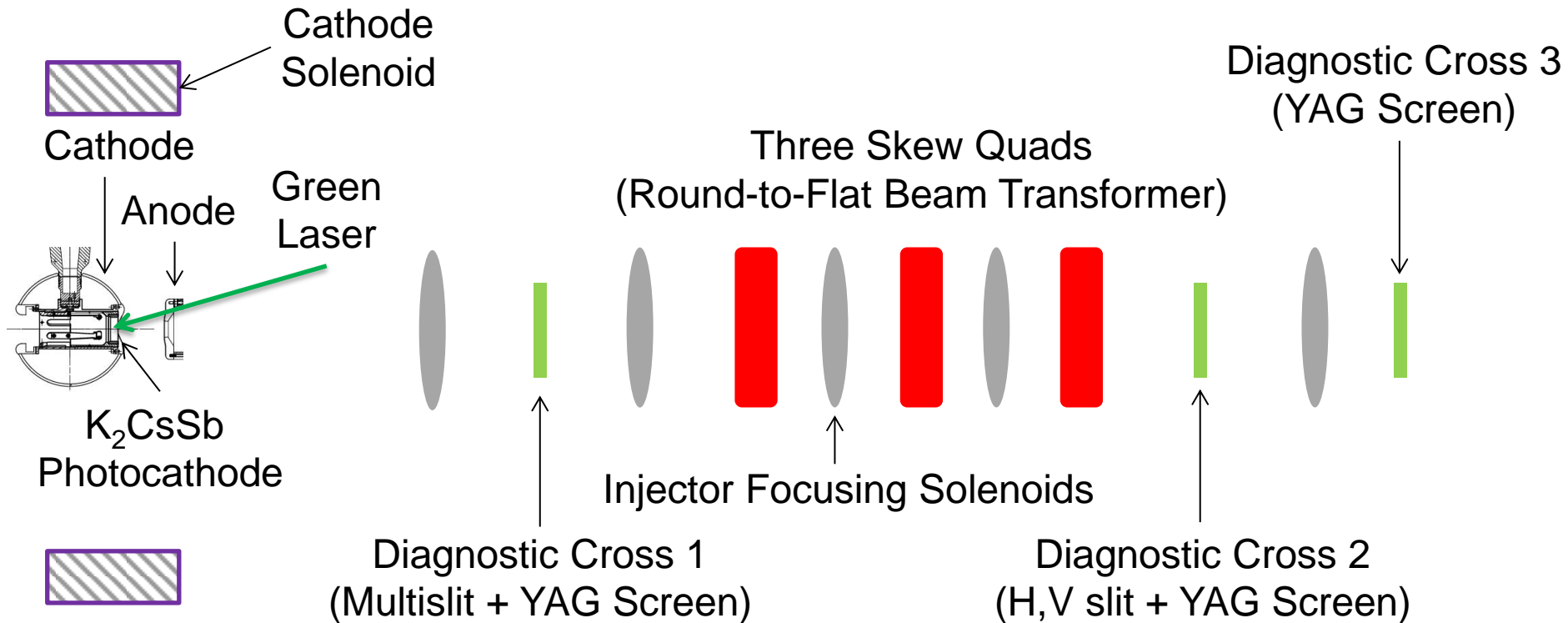

- Generate magnetized beam:
- $a_0 = 1 - 5$ mm, $B_z = 0 - 2$ kG
 - Bunch charge: 1 – 500 pC
 - Frequency: 15 Hz – 476.3 MHz
 - Bunch length: 10 – 100 ps
 - Average beam currents up to 32 mA
 - Gun high voltage: 200 – 350 kV

Simulations
will be
discussed in
Fay's talk

Planned Measurements

1. Measure mechanical angular momentum
2. Measure photocathode lifetime versus solenoid field at high currents (up to 32 mA) and high voltages (200 – 350 kV) limited by in-house HV supplies
3. Study beam halo and beam loss versus magnetization
4. Use skew quads – RTFB Transformer – to generate flat beam and measure horizontal and vertical emittances using slit method
5. Generate very high currents magnetized beam and study beam transport and RTFB versus electron bunch charge

LERF Gun Test Stand

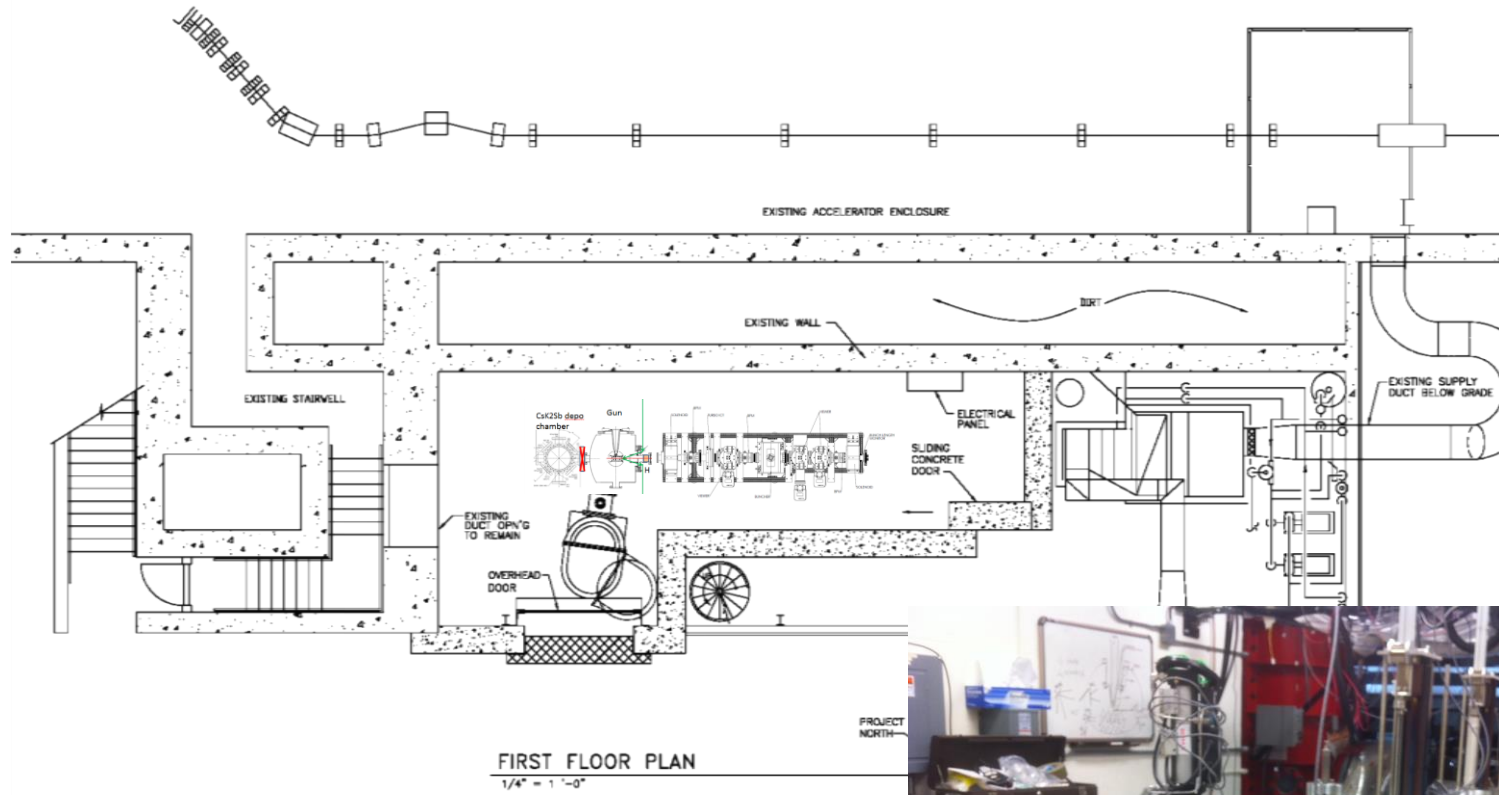

PROGRESS

As of March 29, 2016

✓ Gun: finished HV conditioning, ready to make beam at 325 kV



HV
Chamber

K_2CsSb
Preparation
Chamber

Thanks to
Carlos, Bubba,
Phil and Yan

✓ K_2CsSb Preparation Chamber: ready to grow photocathodes

✓ Beamline: connected to gun, baked and now instrumenting steering coils, ion pumps and viewers

Thanks to Carlos, Bubba, Jim Coleman, Phil and Shukui

✓ Lasers: ready (LOSP approved)

1. Amplified Nd:YLF Laser system: 15 Hz, 45 ps, green, 1 mJ/pulse energy, ~10 mW (average)
2. Verdi Laser: DC, green, 10 W
3. Antares Mode-locked Nd:YLF Laser: 74.85 MHz, 60 ps, green, 5 W.
To be replaced later with Fiber Laser: 476.3 MHz

➤ Gun Test Stand (GTS) OSP: approved for only 10 nA – working with Radiation Group for approval at full current

✓ Cathode Solenoid Magnet

- Modelled by Jay Benesch
- Provides 1.4 kG at cathode (at 400A) without carbon steel puck
- Bare coil – no cylindrical steel shield/return
- Not bakable – will be mounted on rails. To bake gun, push downstream out of oven and run LCW through.
- Designer: Gary Hays
- Procurement: Tommy Hiatt

Cathode-Anode Gap

Carbon Steel

Molybdenum

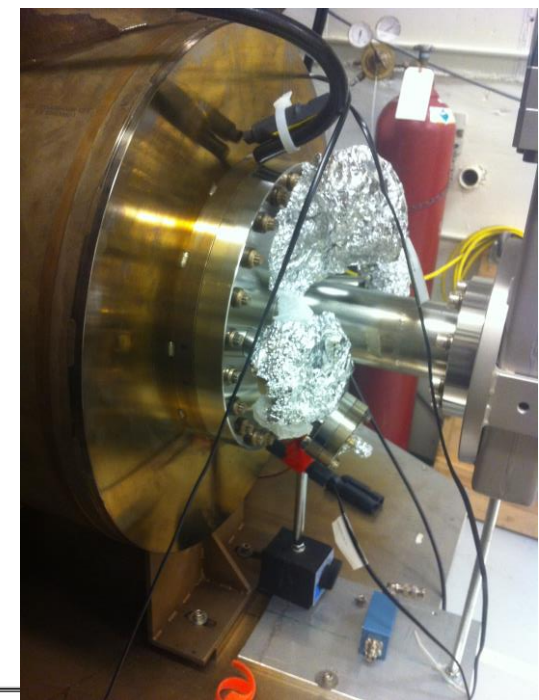
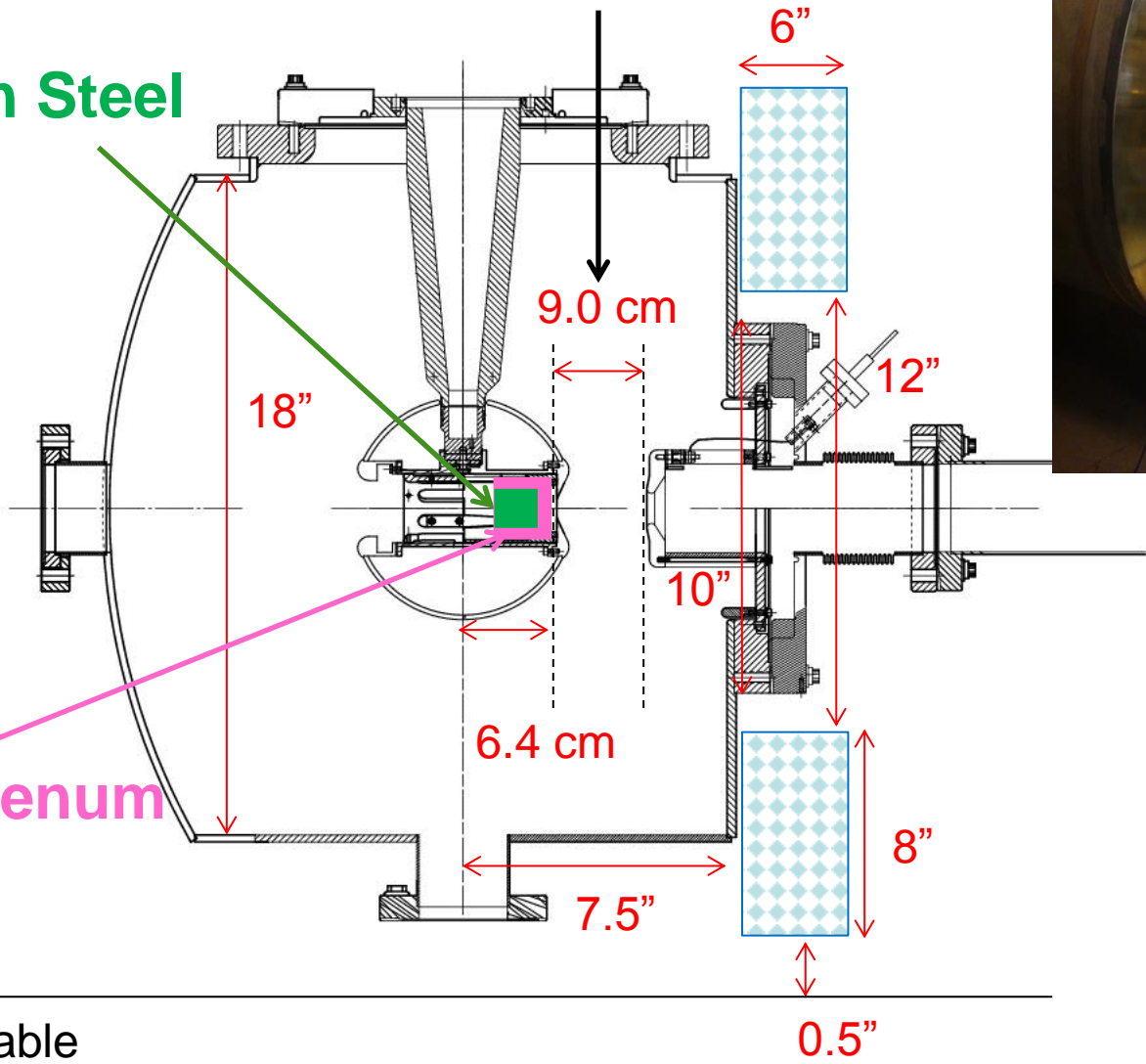

Gun Table

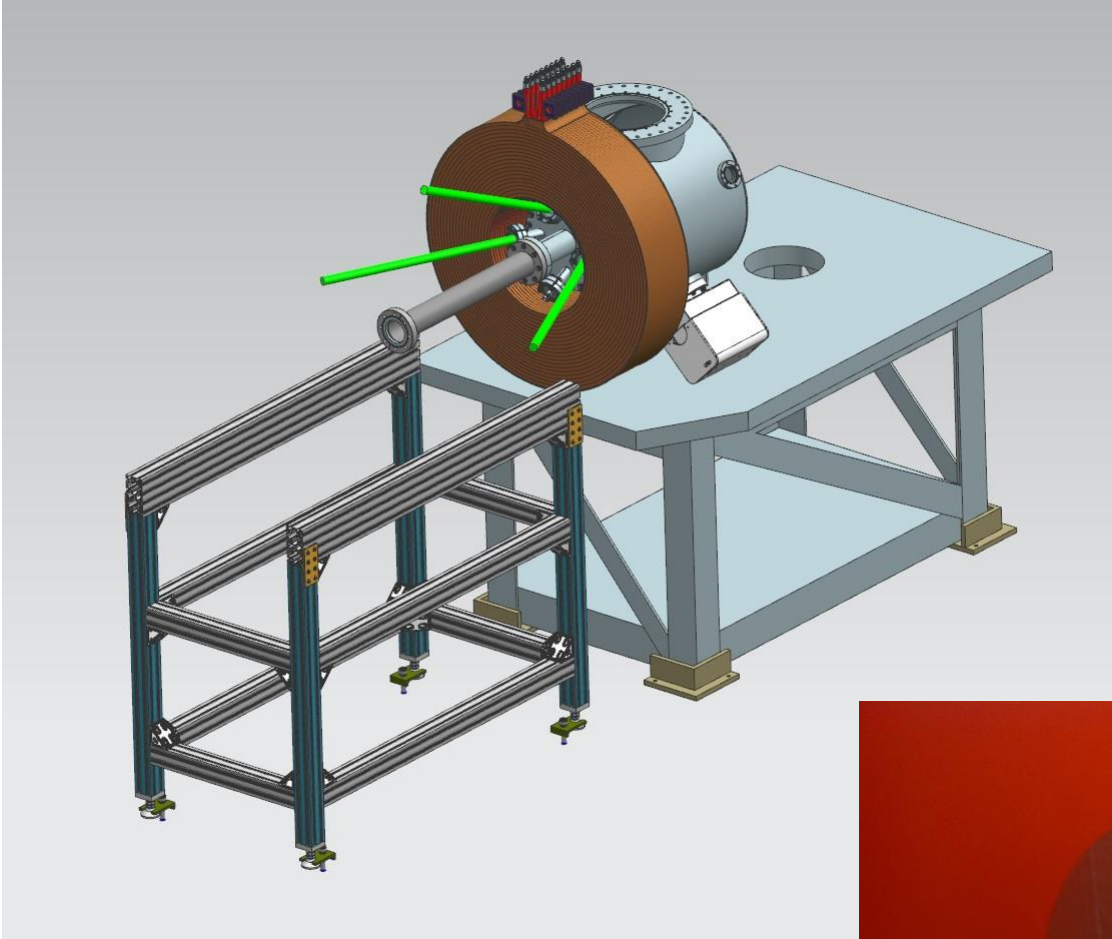

Size	11.811" ID, 27.559" OD, 6.242" Z
Conductor	L=500 m, A=0.53 cm ² 16 layers by 20 turns
Coil Weight	240 kg
Resistance	0.18 Ω (65°C average T)
Field at Photocathode	1.4 kG
Voltage	72 V
Current	400 A

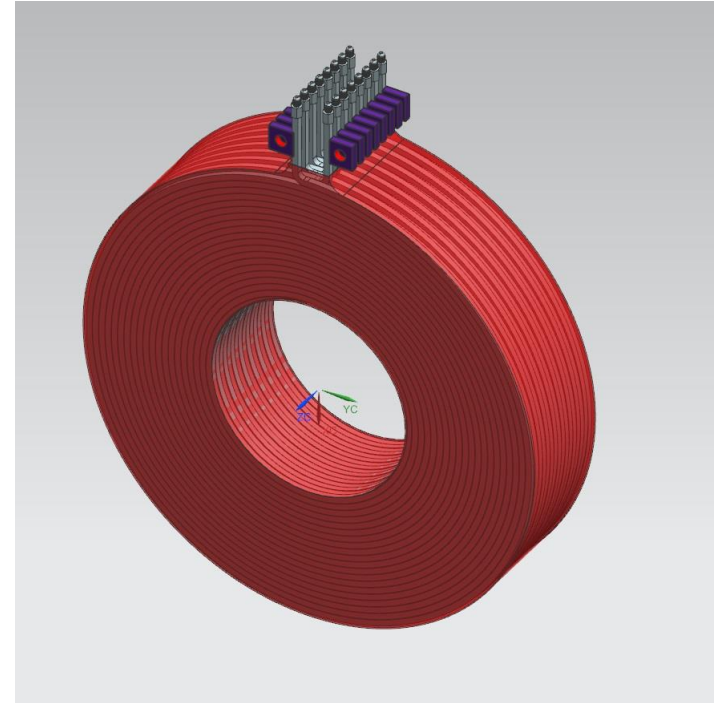

➤ Solenoid ESH&Q:

- I. Measure 5 G magnetic field line and mark with signs
- II. Add interlocks to concrete shield door and a beacon, to ensure solenoid can only be energized when door is closed

➤ Cathode Solenoid Support

To be able to bake gun – move magnet away from gun and out of oven

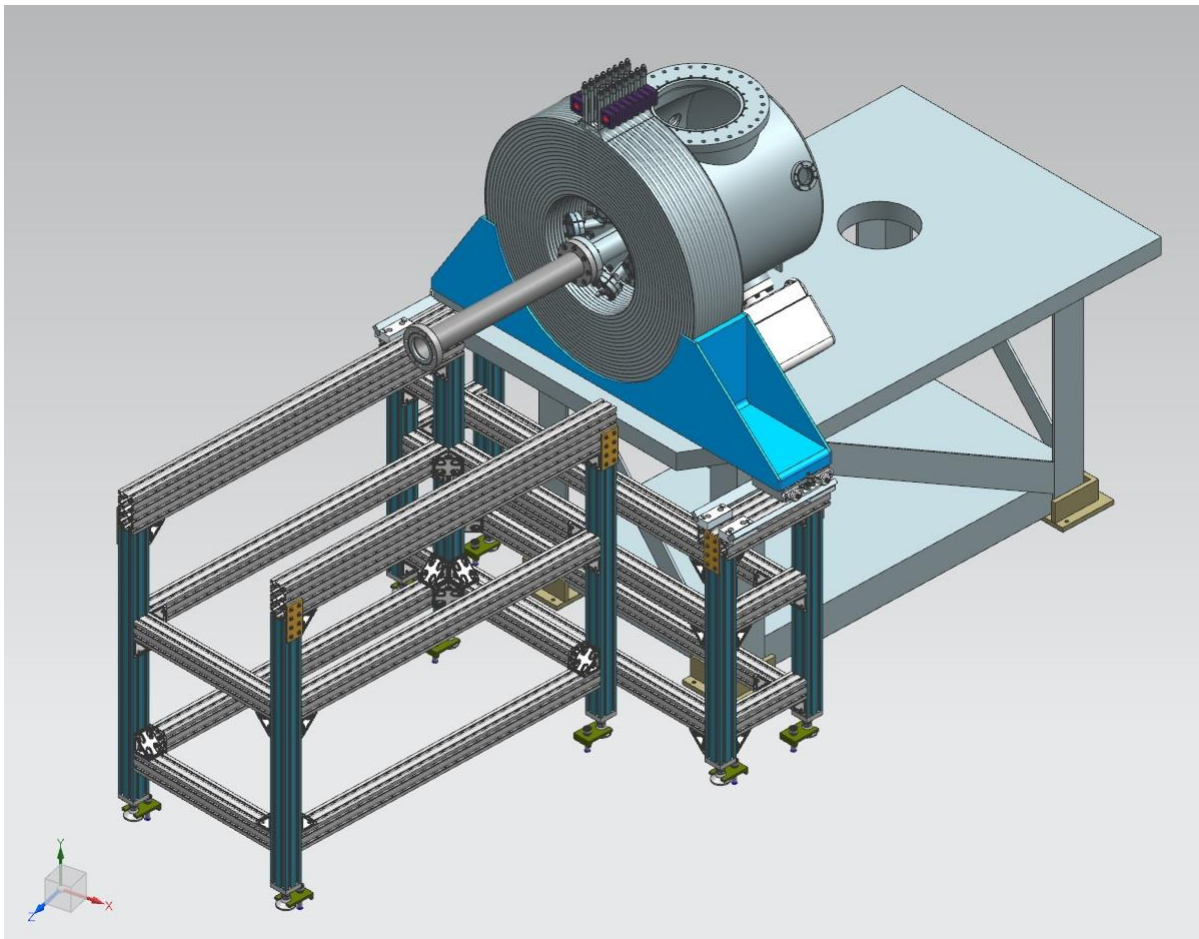

Allow for small adjustments to center solenoid on beam – 5 mm in x and y

✓ Cathode Solenoid Power Supply

- Use new spare CEBAF Dogleg magnet power supply (500A, 80V)
- If needed at CEBAF, we can use an old Dogleg supply (250A, 50V) to keep going

✓ Carbon Steel Puck

- Molybdenum and carbon steel hybrid puck
- Designed to enhance field to 2.0 kG at cathode
- Use 1010 carbon steel
- Re-design new Puck Manipulator End Adapter
- Order 4 pucks – map with solenoid (August 2016)
- Pucks heat treatment plan – 4 choices:
 1. Un-heated
 2. 200°C (Sb growth) and 120°C (K – Cs growth)
 3. 550°C (heat cleaning) then 200°C and 120°C
 4. Multiple heat cycles

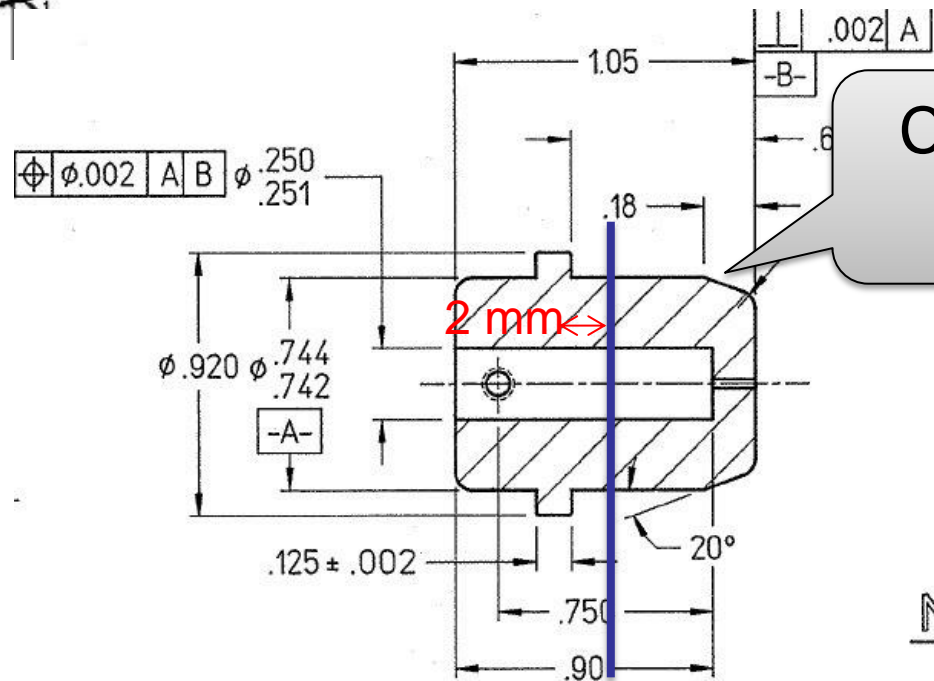
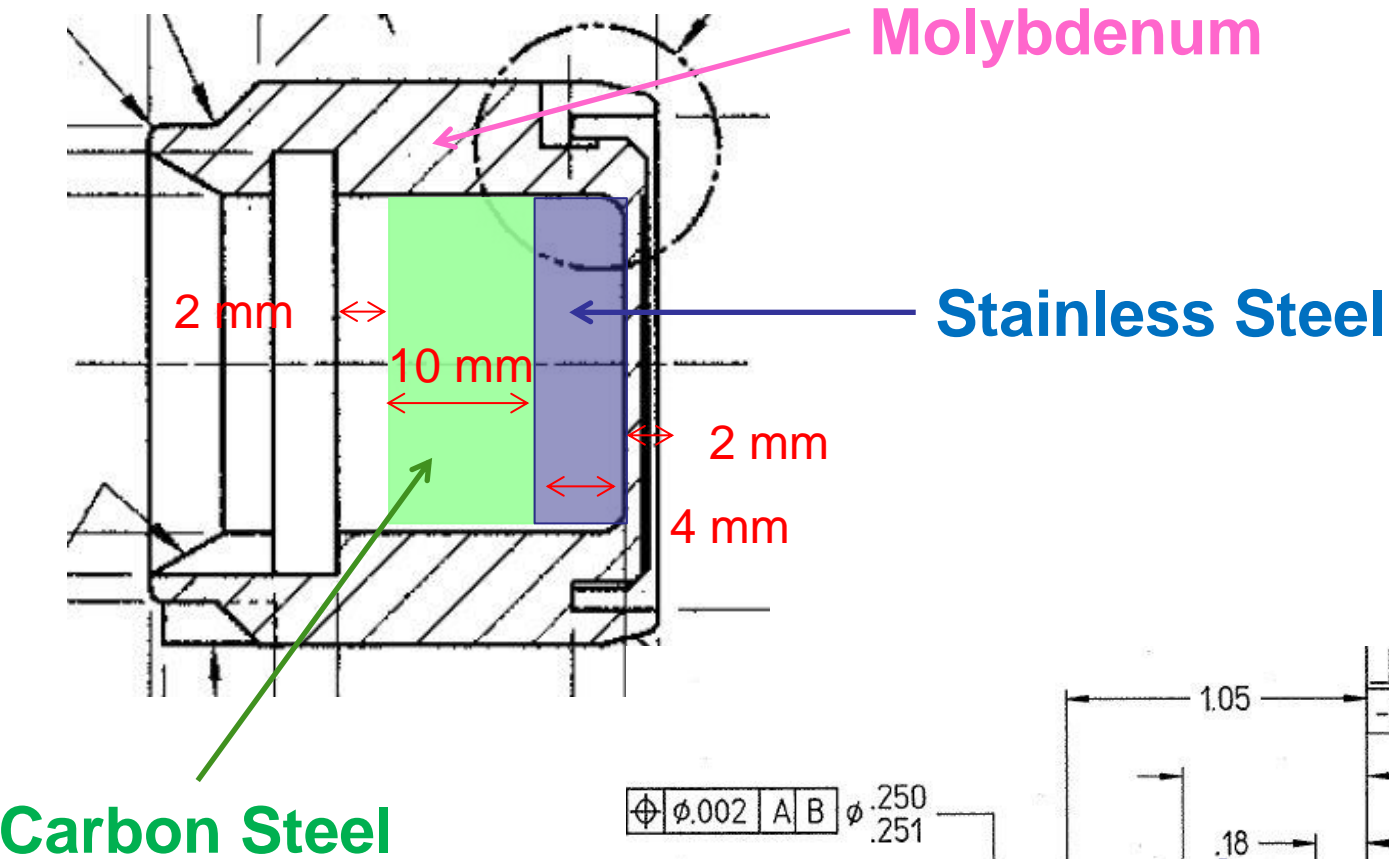

Cut this part

NC

Cathode Solenoid Timeline

Power Supply (new spare Dogleg):

1. Build at Magnet Lab: March
2. Test: April
3. Move to GTS: May
4. Ready: May 31, 2016

Cathode Solenoid:

1. Designed: December – February
2. Procured: March
3. On-site by July 8, 2016
4. Map (with and w/o puck), check hysteresis and forces: July
4. Install: August, 2016

Will have to break gun vacuum. Plan to change HV ceramic insulator and HV shed, replace leaky gate valve and add NEG pumps. Install slits.

MILESTONES

Year 1 Milestones

- Q1 (Oct, Nov, Dec):
 1. HV condition gun to 350 kV and build K_2CsSb preparation chamber ✓
 2. Design beamline, locate magnets and diagnostics at optimum positions ✓
 3. Design cathode solenoid magnet ✓
- Q2 (Jan, Feb, Mar):
 1. Connect existing beamline to gun and instrument beamline ✓
 2. Procure cathode solenoid magnet ✓
 3. Design and procure slits
- Q3 (Apr, May, Jun):
 1. Commission exiting beamline with beam
 2. Measure photocathode lifetime at 5 mA and 350 kV (not magnetized)
 3. Relocate new spare CEBAF dogleg power supply to GTS
- Q4 (Jul, Aug, Sep):
 1. Install cathode solenoid magnet
 2. Assemble new beamline and commission with beam
 3. Design and procure three skew quads

Year 2 Milestones

- Q1 (Oct, Nov, Dec):
 1. Generate magnetized beam
 2. Measure mechanical angular momentum vs magnetization and laser size
 3. Benchmark simulation against measurements
- Q2 (Jan, Feb, Mar):
 1. Measure mechanical angular momentum vs bunch charge and bunch length
 2. Benchmark simulation against measurements
- Q3 (Apr, May, Jun):
 1. Generate very high currents magnetized beam and study beam transport vs electron bunch charge
- Q4 (Jul, Aug, Sep):
 1. Measure photocathode lifetime vs magnetization at 5 mA and 350 kV
 2. Study beam halo and beam loss vs magnetization

Year 3 Milestones

- Q1 (Oct, Nov, Dec):
 1. Install three skew quads
 2. Generate flat beam with skew quads – RTFB Transformer – and measure horizontal and vertical emittances using slit method
- Q2 (Jan, Feb, Mar):
 1. Measure RTFB transformation versus electron bunch charge
 2. Use simulation to quantify how good or complete RTFB transform
- Q3 (Apr, May, Jun):
 1. Change to HV Supply of 32 mA and 200 kV
- Q4 (Jul, Aug, Sep):
 1. Measure photocathode lifetime vs magnetization at 32 mA and 200 kV
 2. Study beam halo and beam loss vs magnetization

BACKUP SLIDES

Magnetized Cooling

- JLEIC bunched magnetized electron cooler is part of Collider Ring and aims to counteract emittance degradation induced by intra-beam scattering, to maintain ion beam emittance during collisions and extend luminosity lifetime.
- Electrons helical motion in strong magnetic field increases electron-ion interaction time, thereby significantly improving cooling efficiency. Electron-ion collisions that occur over many cyclotron oscillations and at distances larger than cyclotron radius are insensitive to electrons transverse velocity.
- Cooling rates are determined by electron longitudinal energy spread rather than electron beam transverse emittance as transverse motion of electrons is quenched by magnetic field
- This cyclotron motion also provides suppression of electron-ion recombination

Electron beam is being used inside cooling solenoid where it suffers an azimuthal kick when it enters. This kick is cancelled by an earlier kick at exit of cathode solenoid

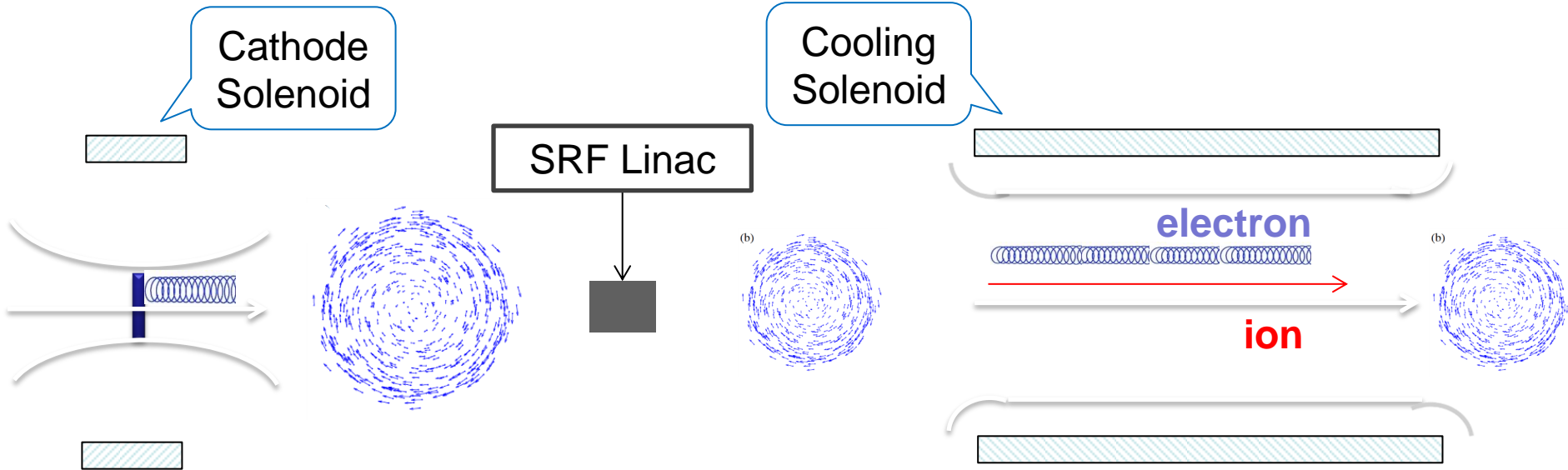

Electrons born in strong uniform B_z

$$\langle L \rangle = \frac{eB_z a_0^2}{4}$$

$$a_0 = R_{\text{laser}} = 4.4 \text{ mm}$$

$$B_z = 2 \text{ kG}$$

Upon exit of Cathode Solenoid

$$\langle L \rangle = \gamma m_e \langle r^2 \rangle \dot{\phi}$$

$$\varepsilon_d = \frac{eB_z a_0^2}{8m_e c} = 284 \text{ } \mu\text{m}$$

Upon entering Cooling Solenoid

$$\langle L \rangle = \frac{eB_{\text{cool}} r_e^2}{4}$$

$$\frac{B_{\text{cool}}}{B_z} = \frac{a_0^2}{r_e^2}$$

$$r_e = 1.4 \text{ mm}$$

$$B_{\text{cool}} = 2 \text{ T}$$