

Magnetized Beam LDRD: Design Tasks

February 19, 2016

Magnetized Gun

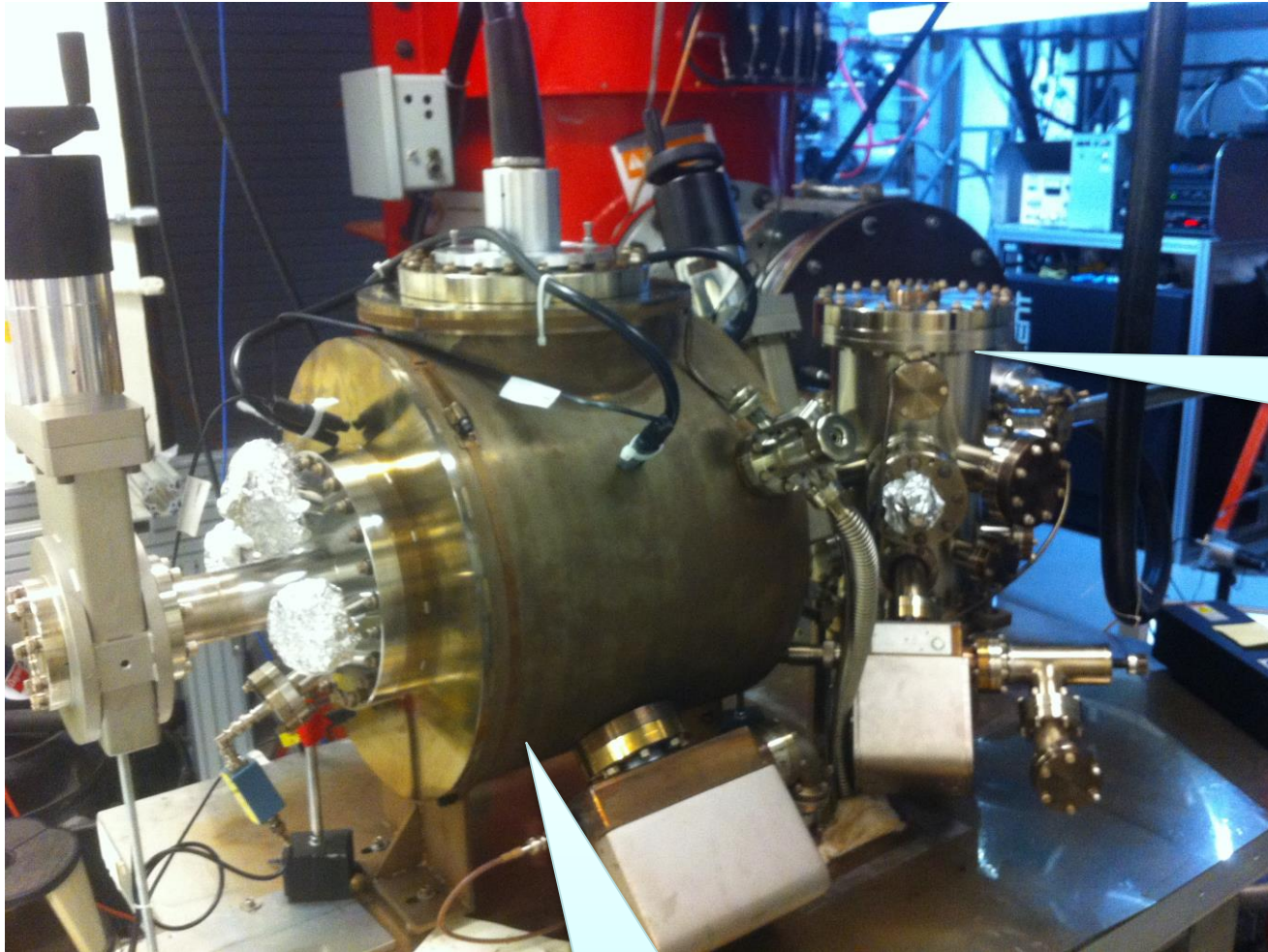

K₂CsSb
Preparation
Chamber

HV Chamber

Solenoid + Steel Puck

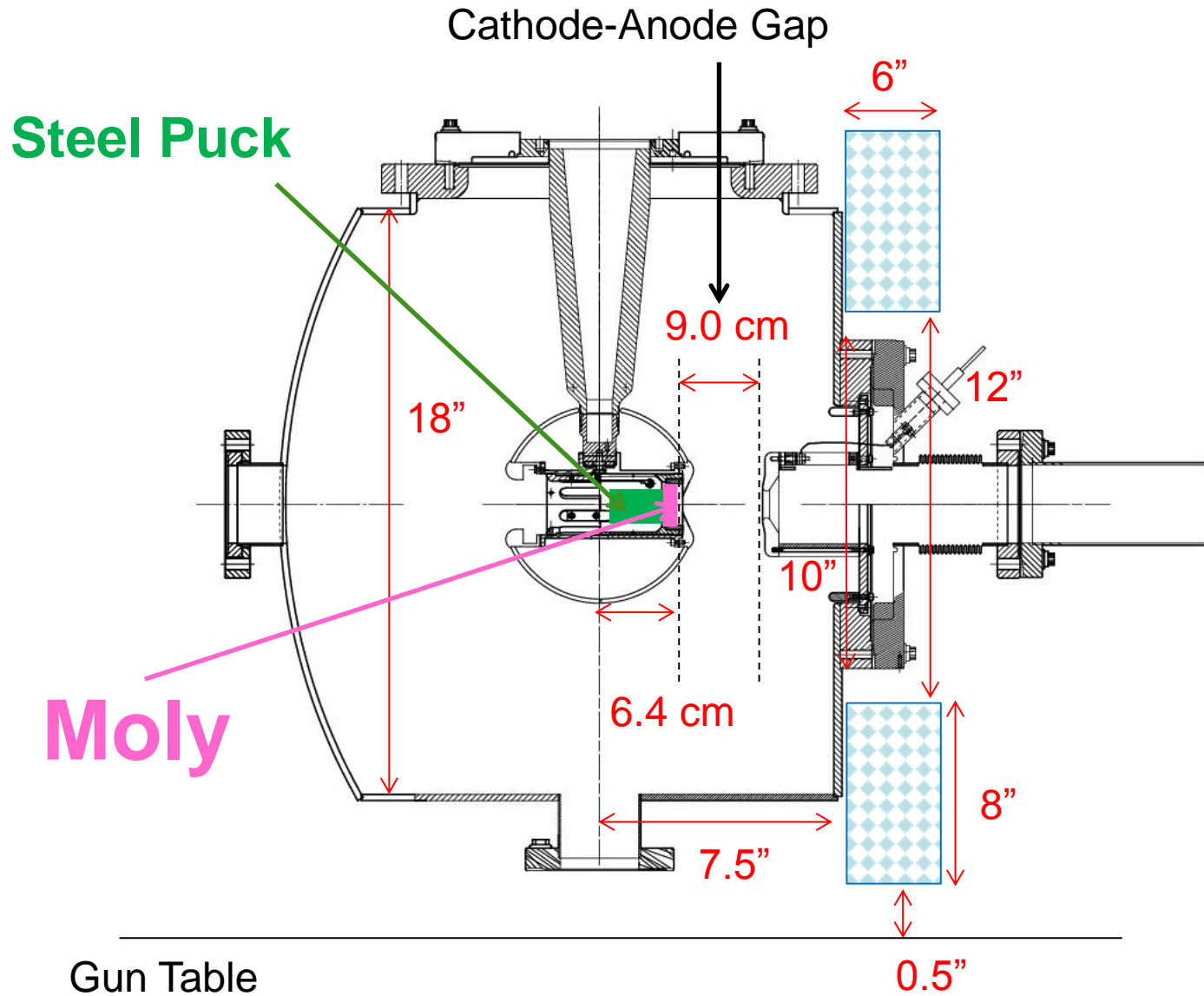

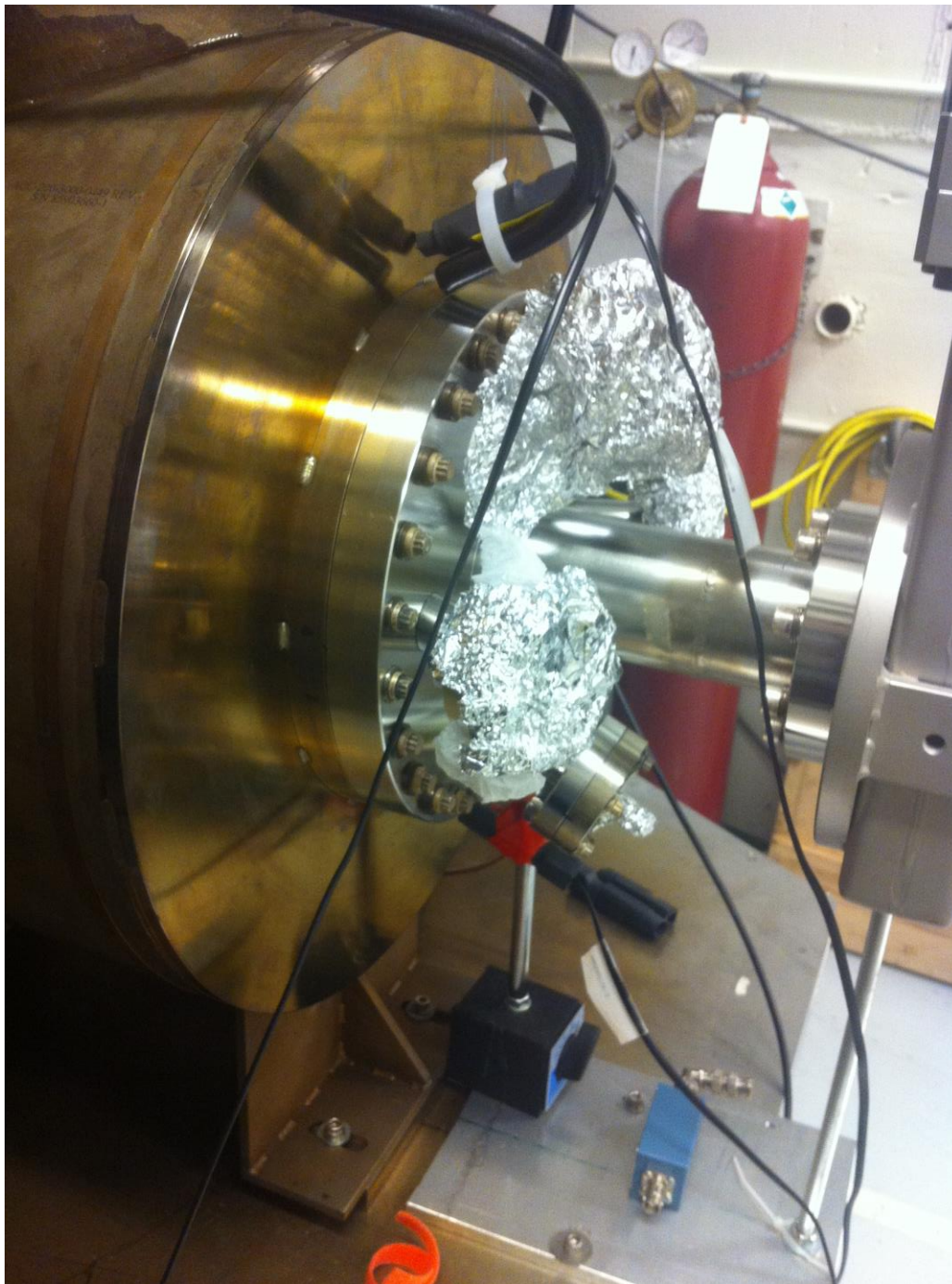

Update
Cathode,
Anode, and
10" flange
in drawing

Steel Puck

- Molybdenum and Steel hybrid puck
- Use 1010 carbon steel
- New Puck Manipulator End Adapter

Design I

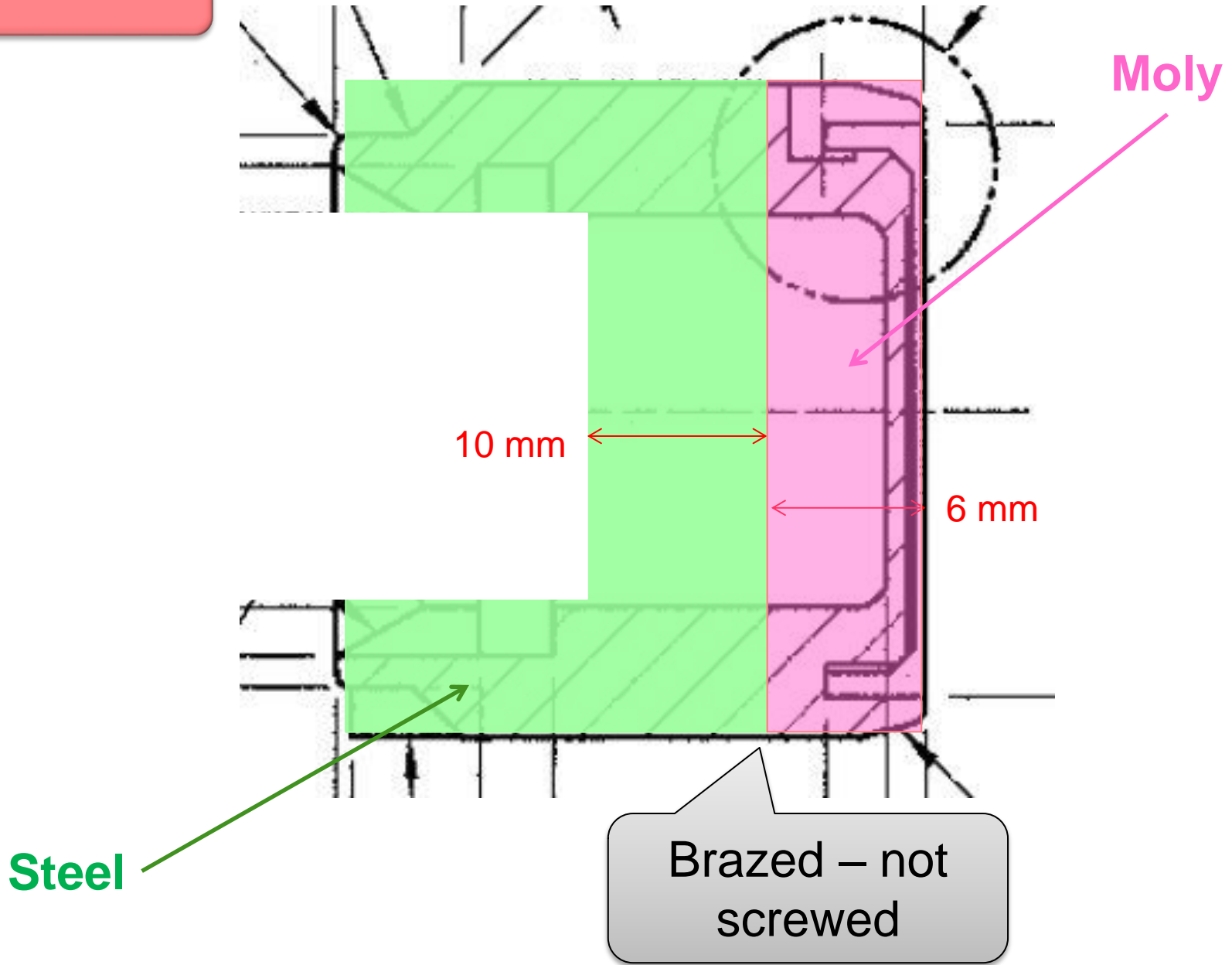

Design II

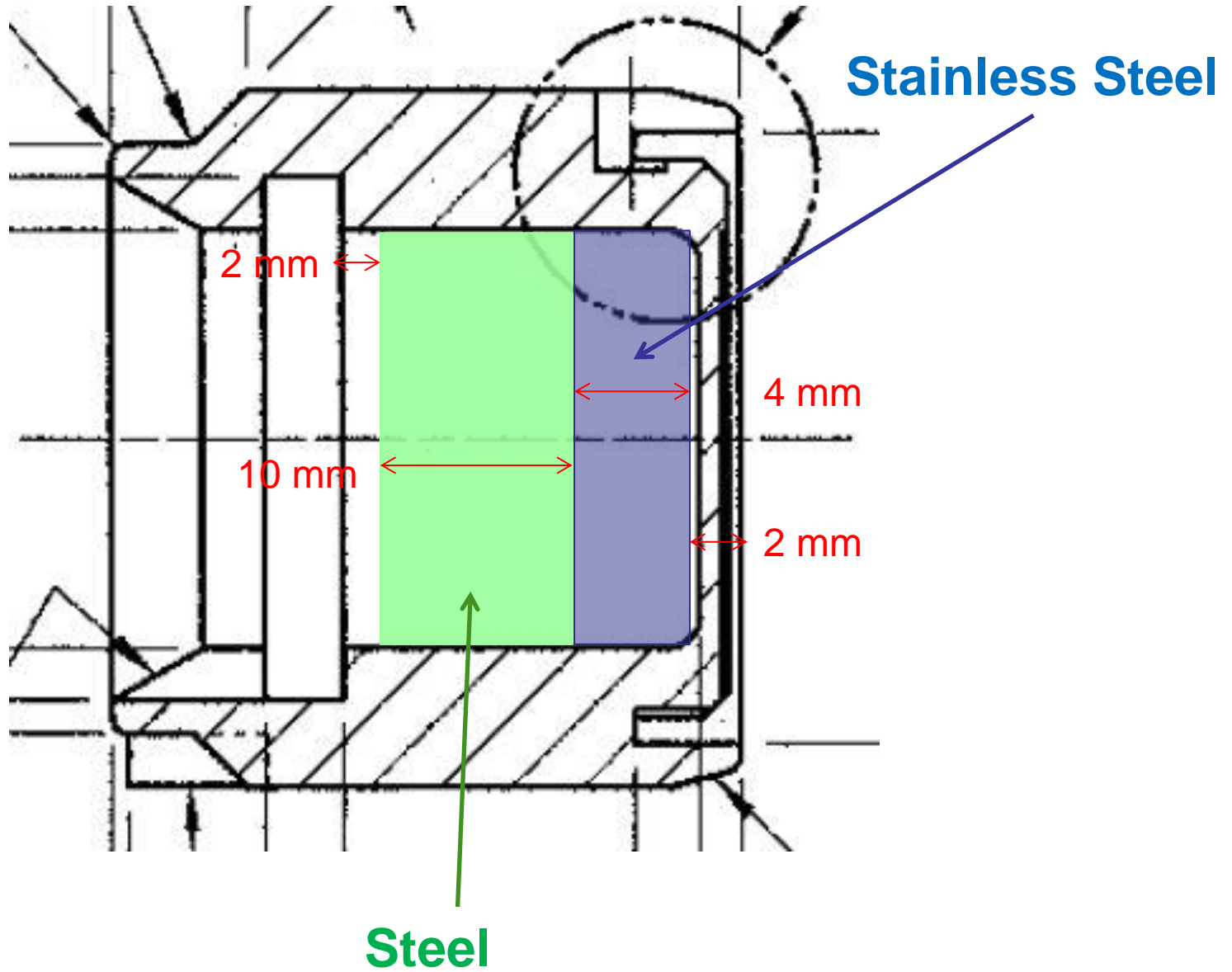

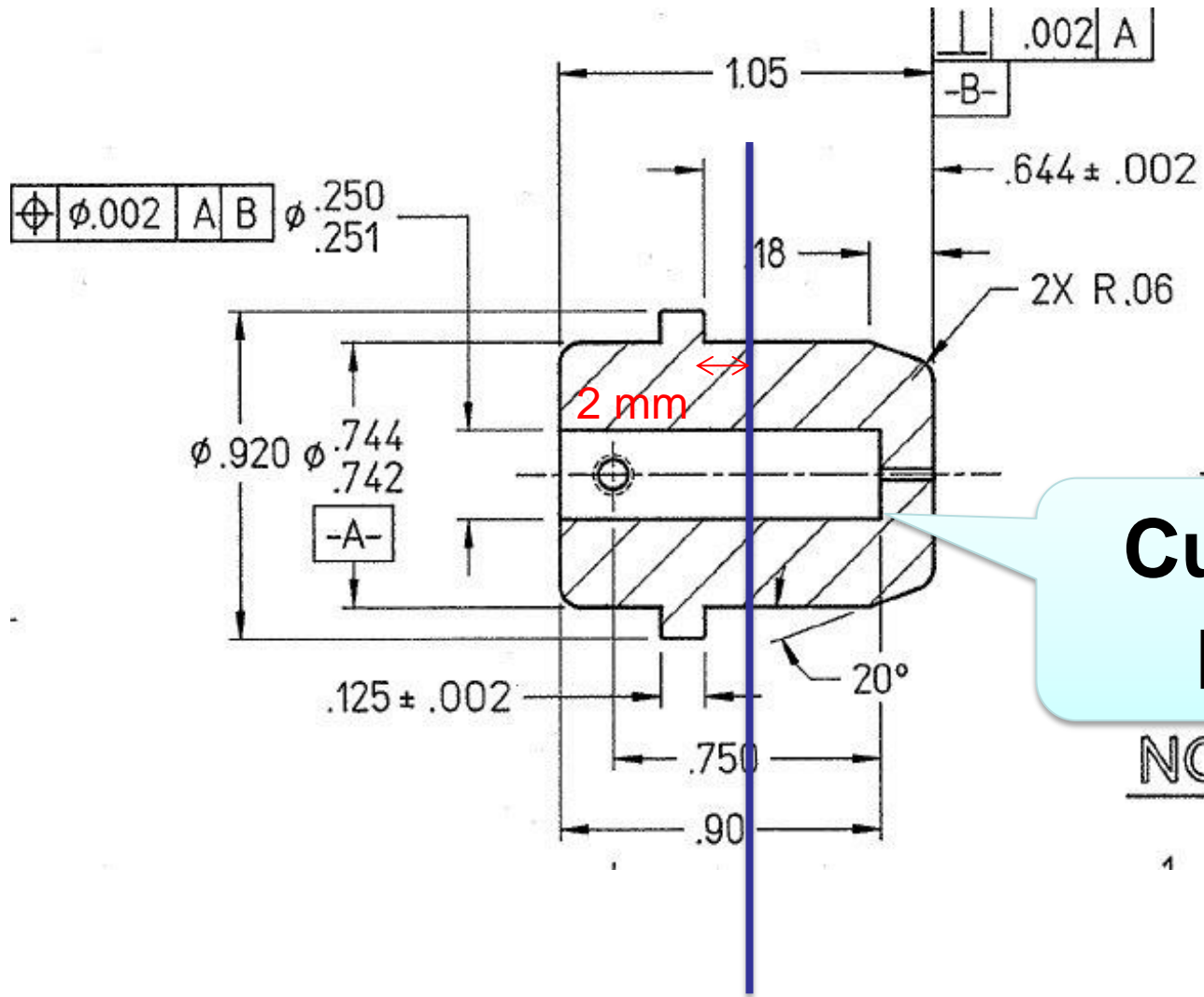

Cut this part

NC

1

Solenoid

- Not bakable – will be mounted on rails. To bake gun: push downstream out of oven and run LCW through. Move gate valve after beamline solenoid (in place of BPM). Move HV Chamber front foot upstream
- Bare coil – no cylindrical steel shield/return
- Procurement (with help from T. Hiatt):
 1. Everson Tesla
 2. Buckley Systems
 3. Alpha Magnetics
 4. JLab Machine shop

Solenoid Specs

- One water cooled magnet coil
- Inside diameter 30 cm, round to 0.2 cm
- Outside diameter roundness: 0.5 cm
- Flatness, each side, 0.3 cm
- Eight double pancakes of 20 turns each using Luvata 6092 or equivalent copper conductor, 9 mm square with 6 mm round hole for water cooling. These may be soldered or bolted together as vendor prefers, see also potting options below. Vendor should propose input/output flags suitable for 450A.
- Eight parallel water cooling circuits, one per double pancake, with 37° flare JIC tube fittings. All eight water connections shall be located on the coil outer diameter within a 15 degree region of the assembly. Vendor shall provide a cooling water specification (flow rate and pressure) for each water circuit assuming 450A current and water inlet temperature of 35°C.
- Coil cross-section shall be less than 16 cm Z by 20 cm R.
- Vendor shall propose insulation system. Glass-epoxy with at least 110°C capability preferred. Potting may be done as a “bag job”. Tooling could also be built to pot four double pancakes as a coil half with four water circuits and two leads. Bolted jumper plate to electrically join the two halves shall be provided in this case. Or full depth tooling can be built.
- Power supply is 500A, 80V and we plan to operate at 450A and 72V.

Solenoid Mounting

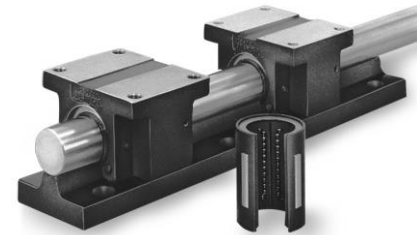
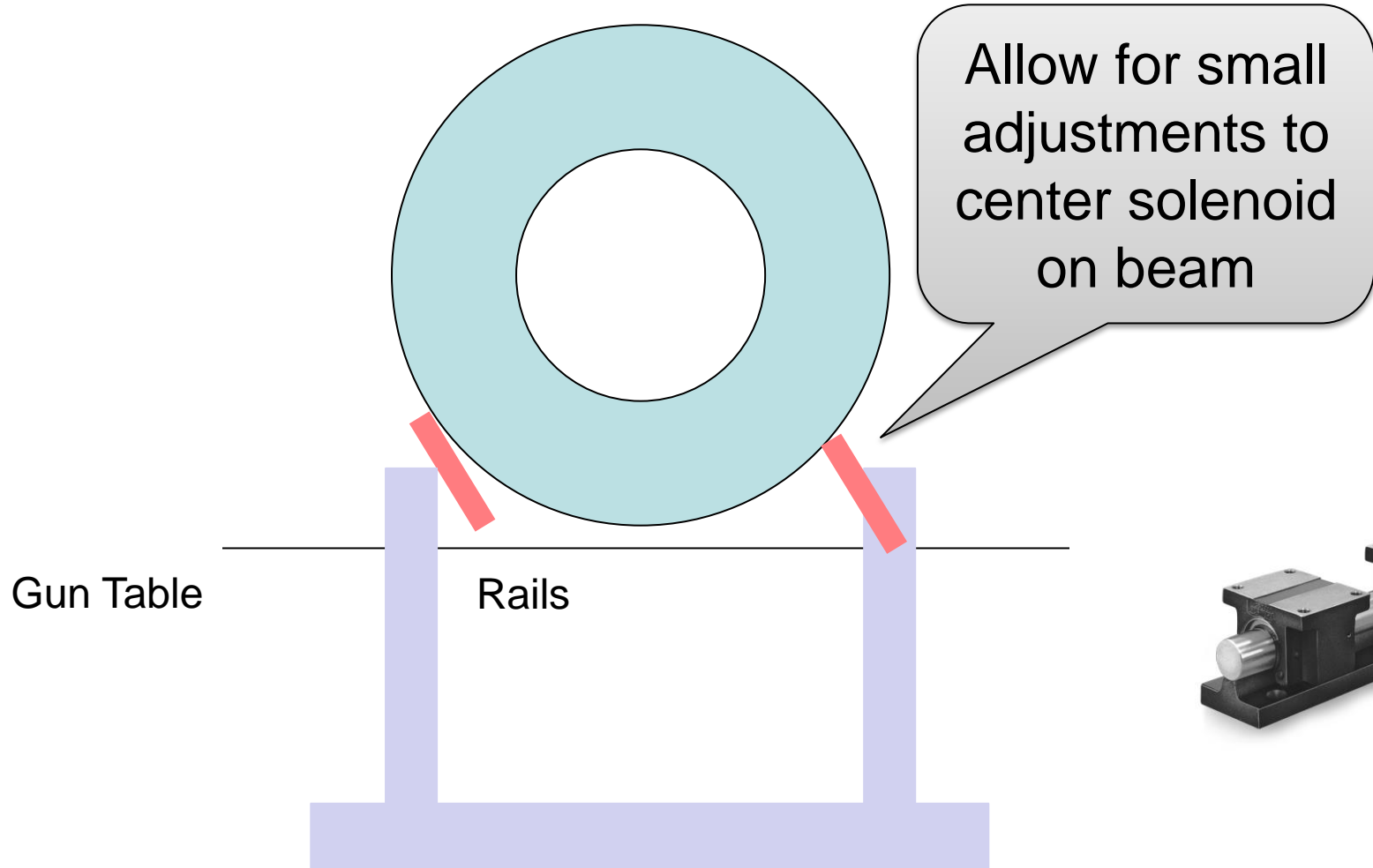

Design Tasks

1. HV Chamber: update cathode, anode and 10” flange
2. Beamline: draw up to 3 feet downstream
3. Magnet Coil:
 1. Fit to 10” flange, laser ports, gun table
 2. Drawing for machine shop
 3. Mounting
4. Steel puck and puck manipulator