

Update:
Puck and Gun Magnet

March 1, 2016

Magnetized Gun

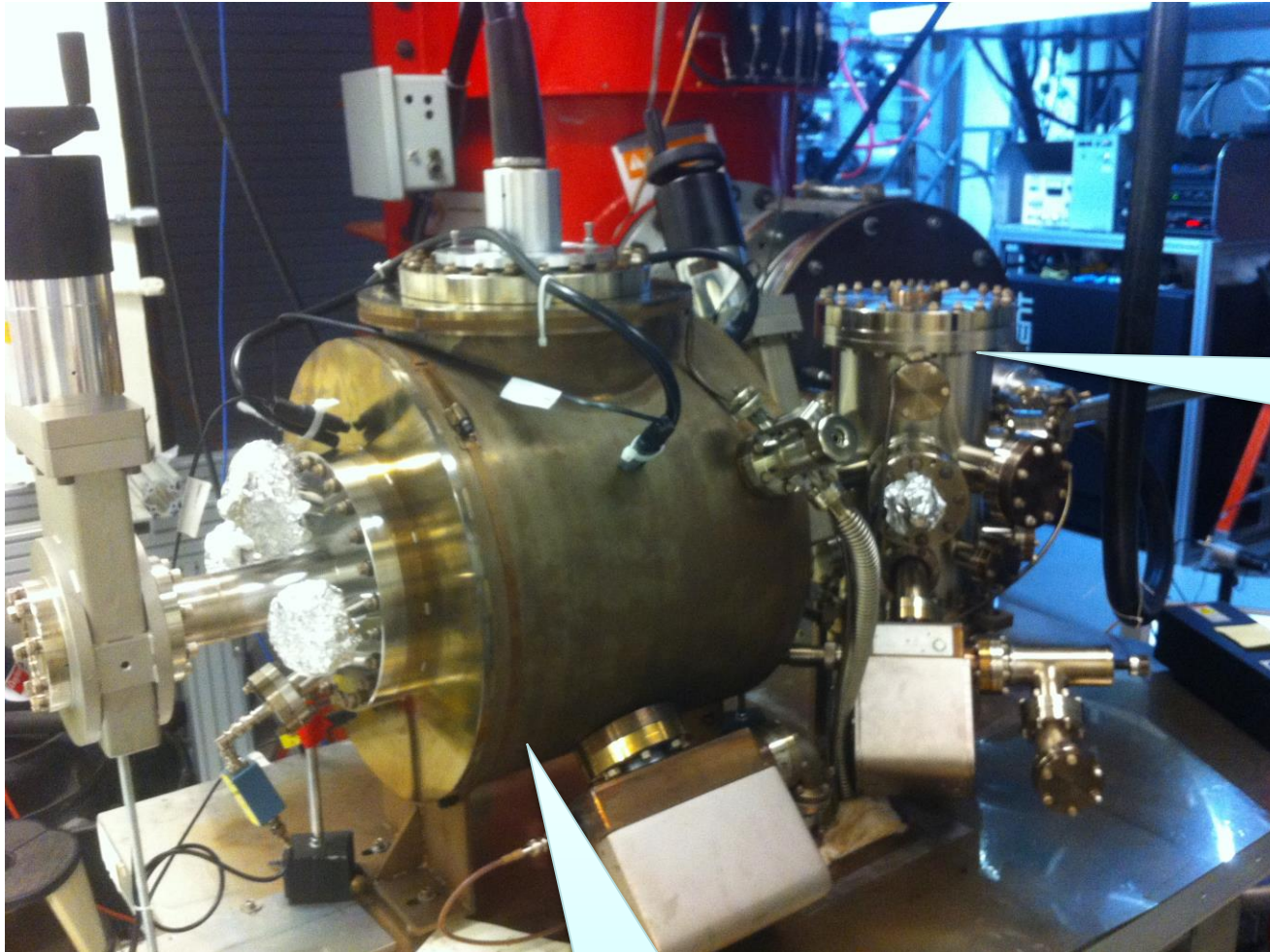

K₂CsSb
Preparation
Chamber

HV Chamber

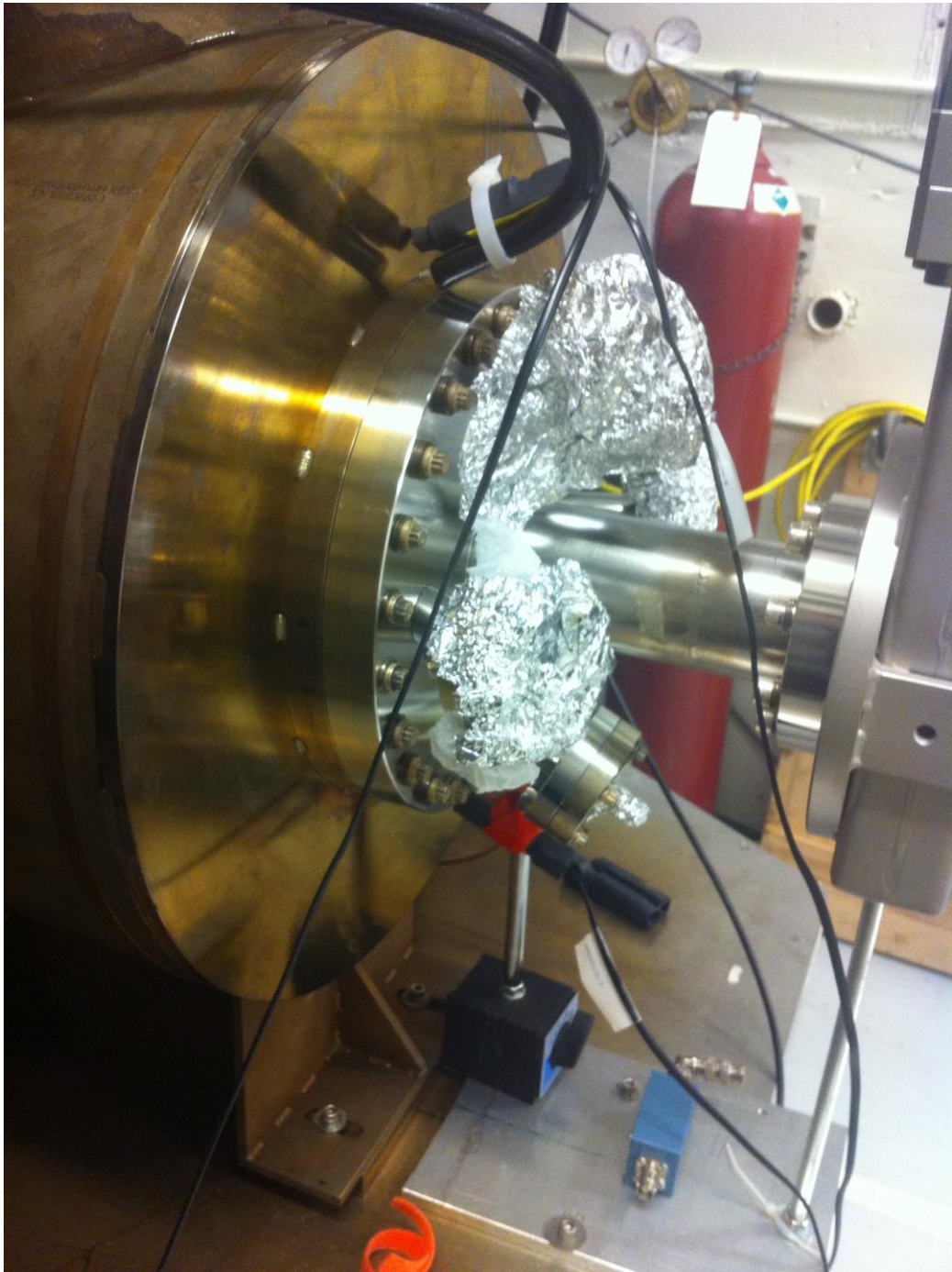

Coil + Steel Puck

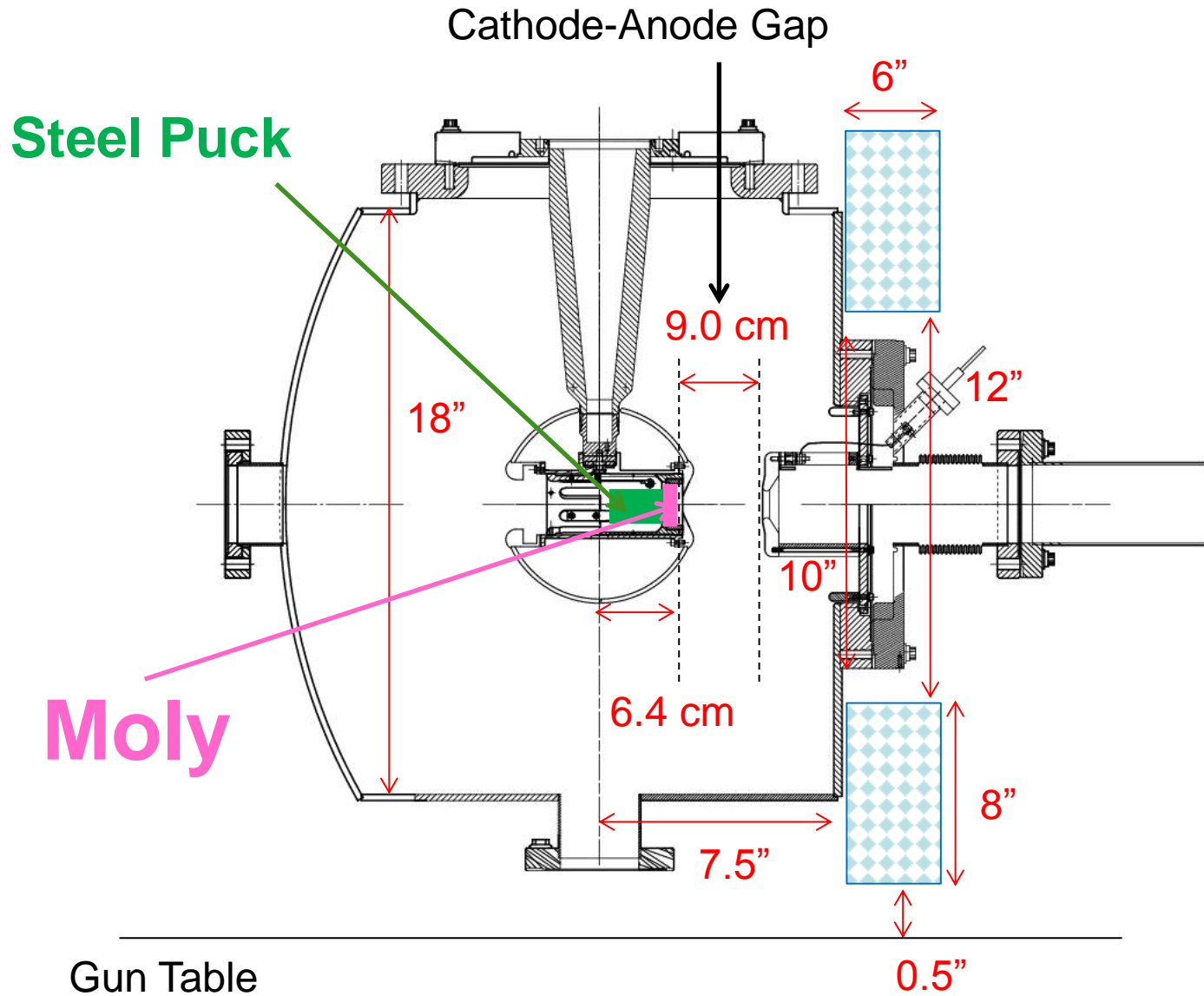

Gun Table

Steel Puck

- Molybdenum and Steel hybrid puck
- Designed to enhance field to 2.0 kG at cathode
- Use 1010 carbon steel
- Re-design new Puck Manipulator End Adapter
- Order 4 pucks – map with Coil (August 2016)
- Heat Treatment:
 1. Un-heated
 2. 200°C (Sb) and 120°C (K – Cs) growth
 3. 550°C Heat Cleaning then 200°C and 120°C
 4. Multiple

Design I

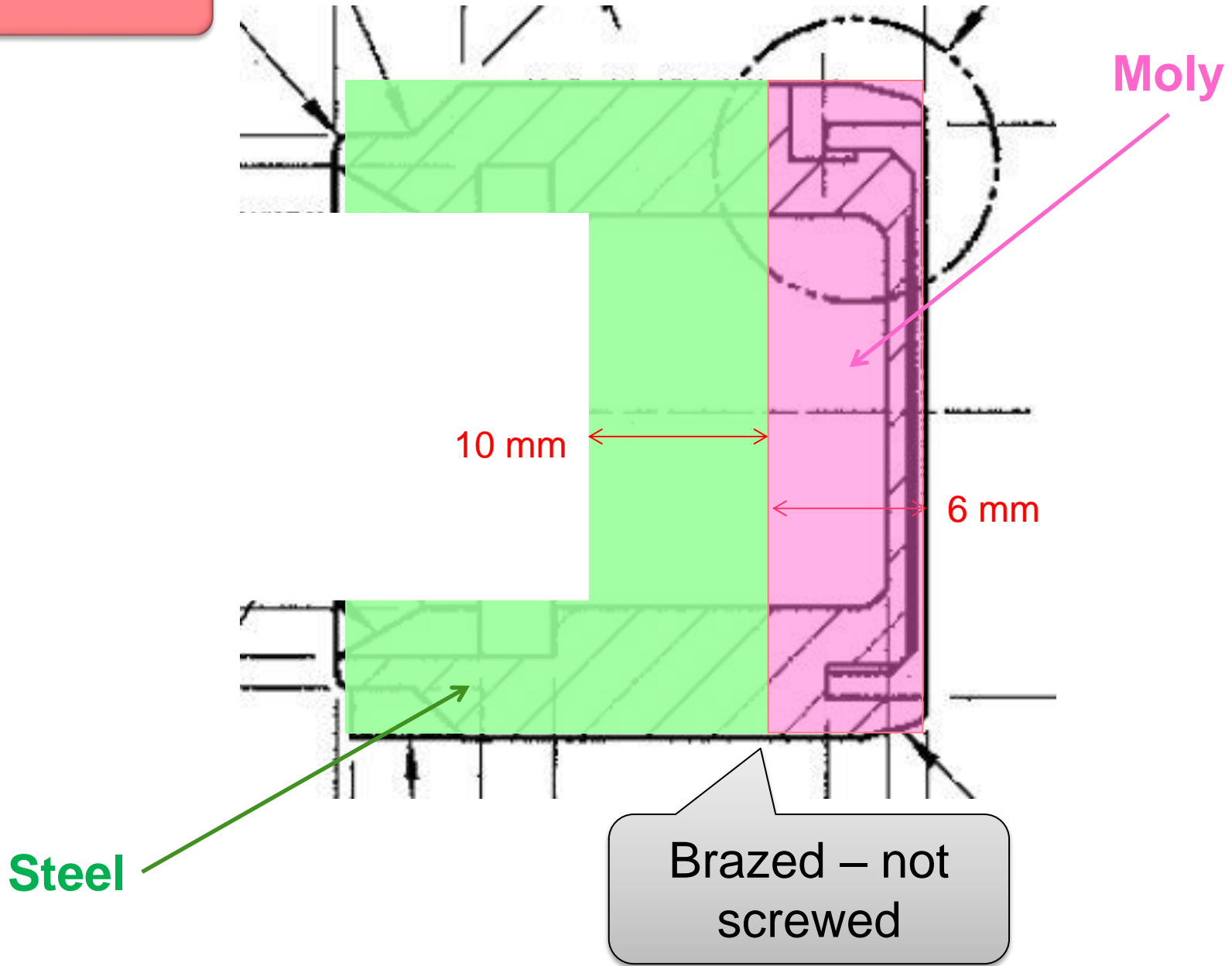

Design II

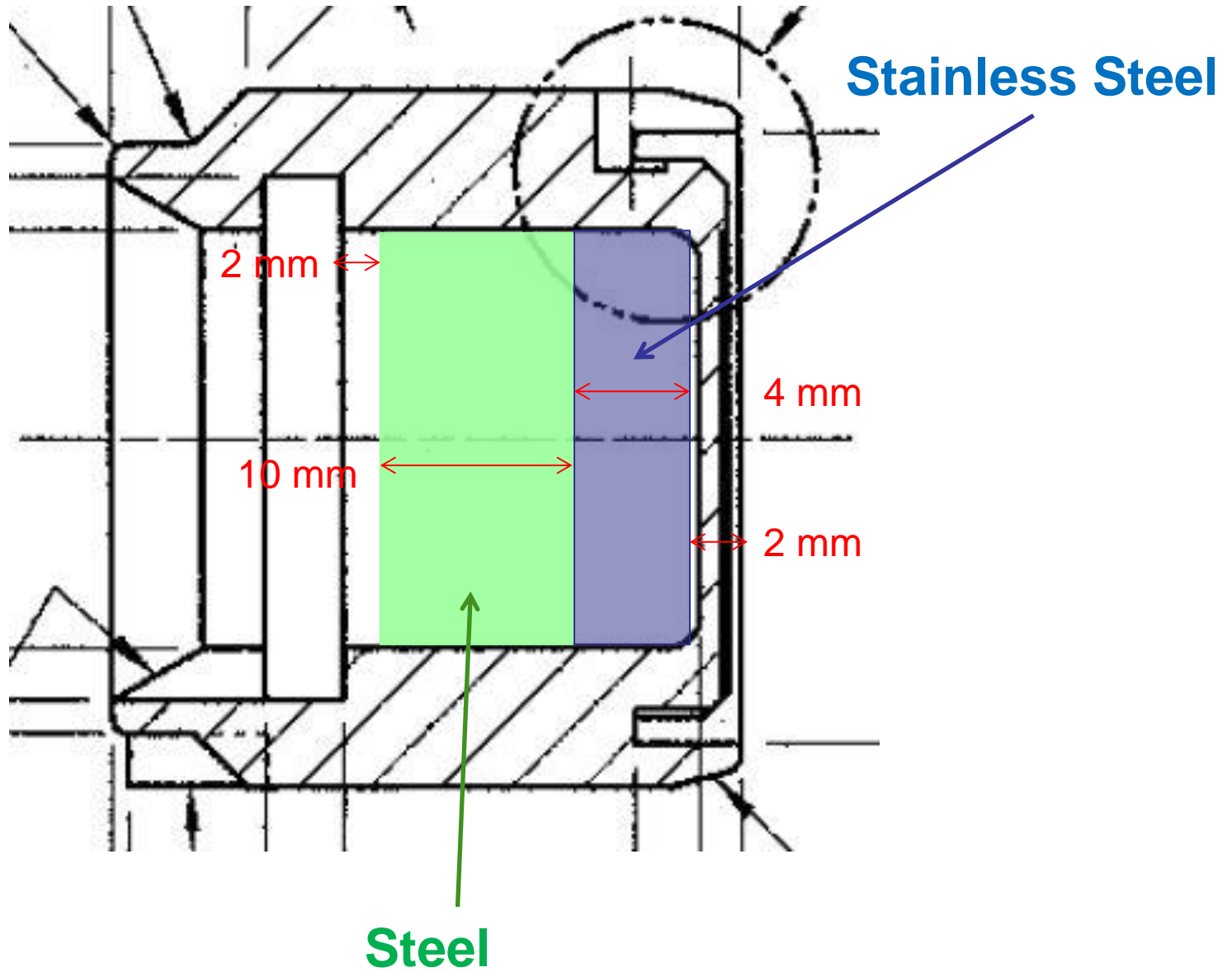

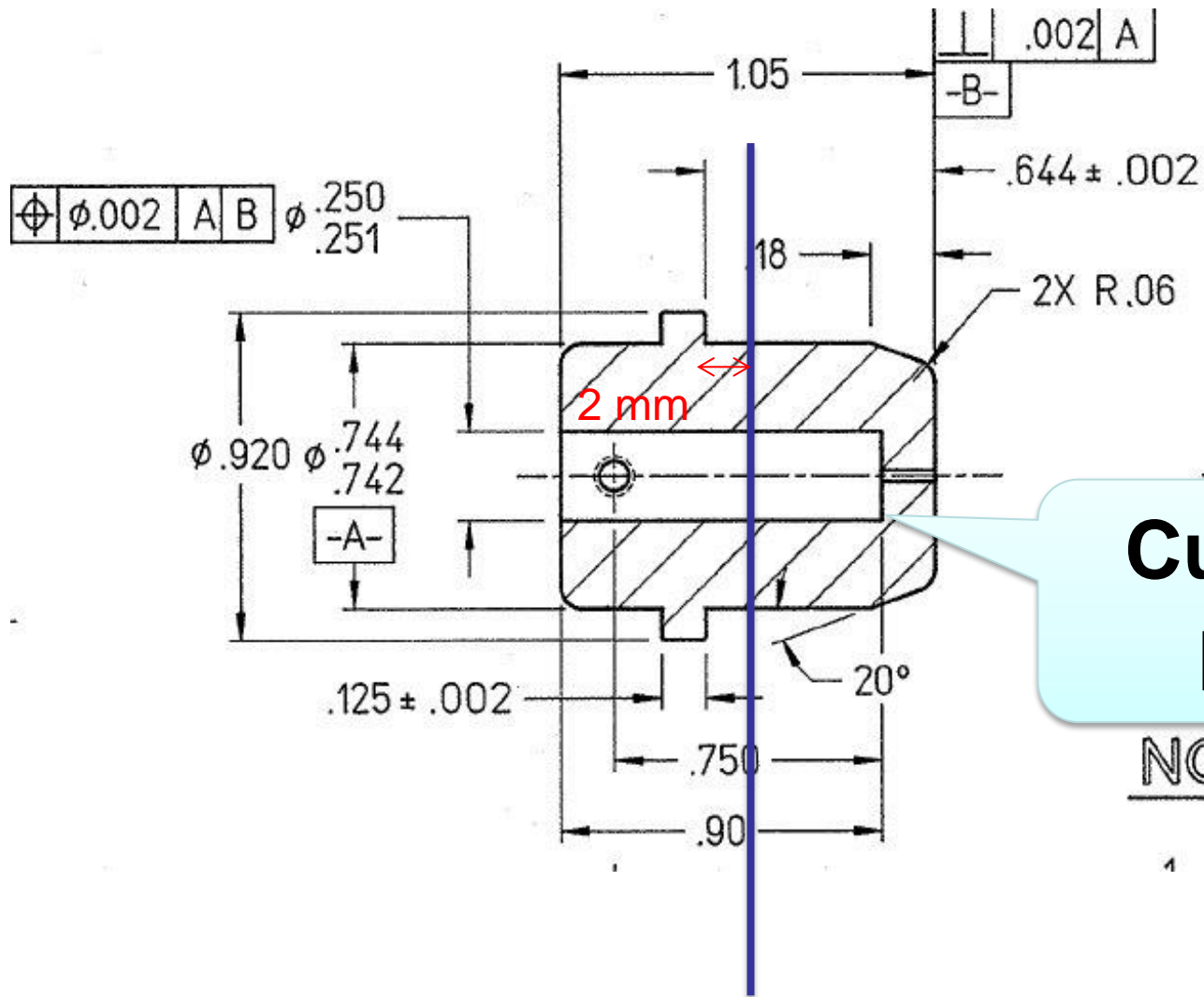

Cut this part

NC

1

Power Supply

- Use new spare Dogleg power supply (500A, 80V)
- If needed at CEBAF, we can use an old Dogleg supply (250A, 50V) to keep going
- Need to add polarity switch to be able to degauss steel

Coil

- Not bakable – will be mounted on rails. Push downstream out of oven and run LCW through. Move gate valve after beamline solenoid (in place of BPM). Move HV Chamber front foot upstream.
- Designed to give 1.4 kG at cathode without steel puck
- Bare coil – no cylindrical steel shield/return
- Procurement:
 1. Everson Tesla
 2. Buckley Systems
 3. Alpha Magnetics (\$20.5k, 12 weeks)
 4. JLab Machine shop
- Designer: Gary Hays

Coil Specs (Jay Benesch)

- One water cooled magnet coil
- Inside diameter 30 cm, round to 0.2 cm
- Outside diameter roundness: 0.5 cm
- Flatness, each side, 0.3 cm
- 8 double pancakes (DP). Each DP has 40 turns. Coil is 16 turns wide by 20 turns radial, 320 turns total. Conductor is Luvata 6092 or equivalent copper conductor, 9 mm square with 6 mm round hole for water cooling. These may be soldered or bolted together as vendor prefers, see also potting options below. Vendor should propose input/output flags suitable for 450A.
- Eight parallel water cooling circuits, one per double pancake, with 37° flare JIC tube fittings. All eight water connections shall be located on the coil outer diameter within a 15 degree region of the assembly. Vendor shall provide a cooling water specification (flow rate and pressure) for each water circuit assuming 450A current and water inlet temperature of 35°C.
- Coil cross-section shall be less than 16 cm Z by 20 cm R.
- Vendor shall propose insulation system. Glass-epoxy with at least 110°C capability preferred. Potting may be done as a “bag job”. Tooling could also be built to pot four double pancakes as a coil half with four water circuits and two leads. Bolted jumper plate to electrically join the two halves shall be provided in this case. Or full depth tooling can be built.
- Power supply is 500A, 80V and we plan to operate at 450A and 72V.

Size	11.811" ID, 27.559" OD, 6.242" Z
Conductor	L=500 m, A=0.53 cm ²
Coil Weight	240 kg
Resistance	0.18 Ω (65°C average T)
Field at Photocathode	1.4 kG
Voltage	72 V
Current	400 A

Resistivity Coefficient: $\rho(20^\circ\text{C}) = (1.72 + 0.00393 \Delta T) 10^{-6} \Omega \text{ cm}$

$R = \rho L/A$, $\rho = 1.90 10^{-6} \Omega \text{ cm}$

- GTS inlet LCW temperature: 35°C and pressure: 5 bar
- Need a booster pump to raise pressure
- What is required flow rate?
- Measure 5 G magnetic field line and mark with sings

Coil Mount

Geometric center vs magnetic center?

Field uniformity at coil center? any beam steering?

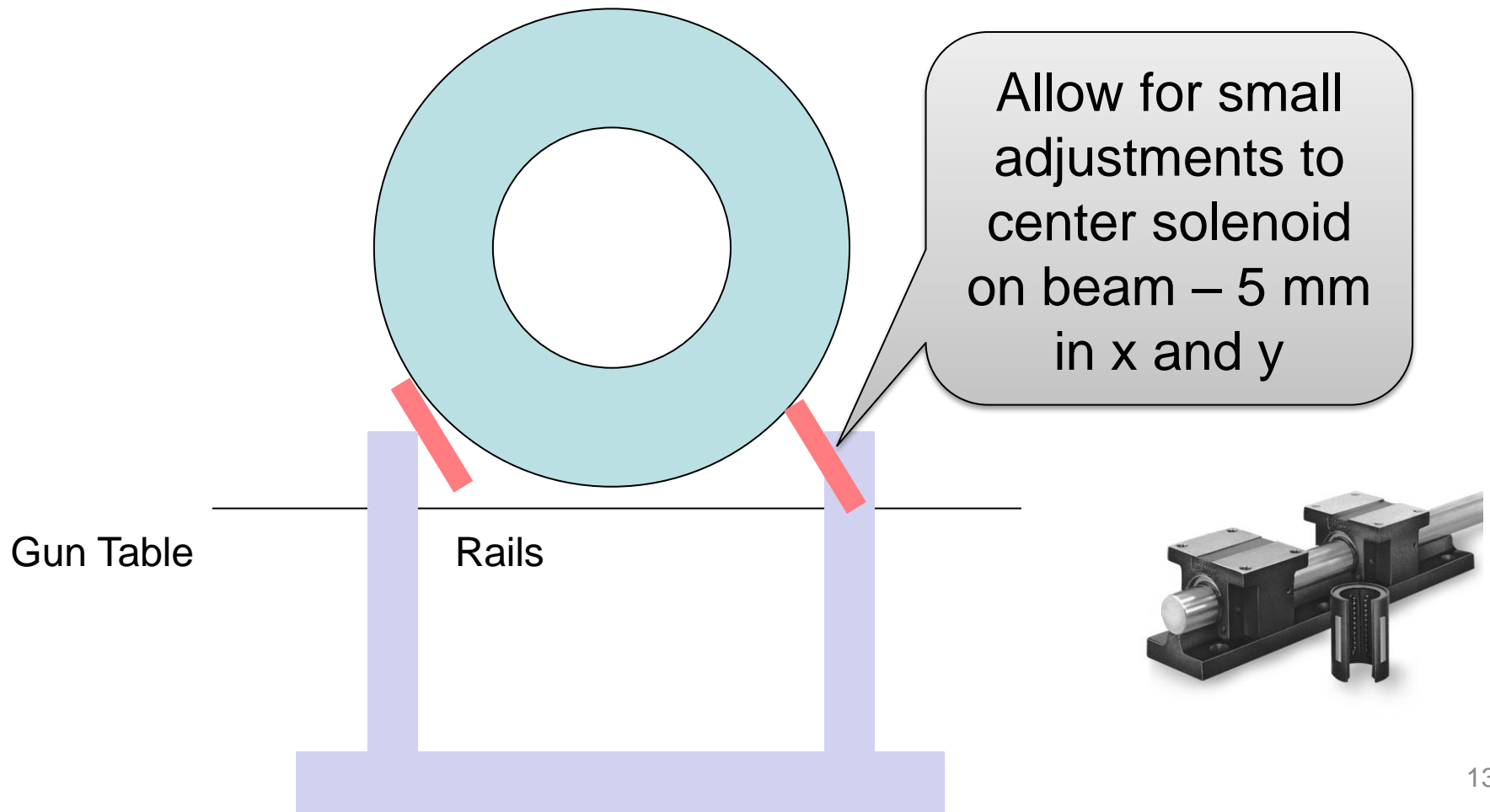

Timeline

Power Supply (new spare Dogleg):

1. Build at Magnet Lab: March
2. Test and add polarity switch: April
3. Move to GTS: May
4. Ready: July 1, 2016

All work has to
be completed
by September
30, 2016

Coil:

1. Design: February and March
2. Procure: April
3. On-site by end of July
4. Map (with and w/o puck), check hysteresis and forces: August
4. Install: August, 2016