

Gun Magnet Design

December 27, 2015

Magnetized Gun

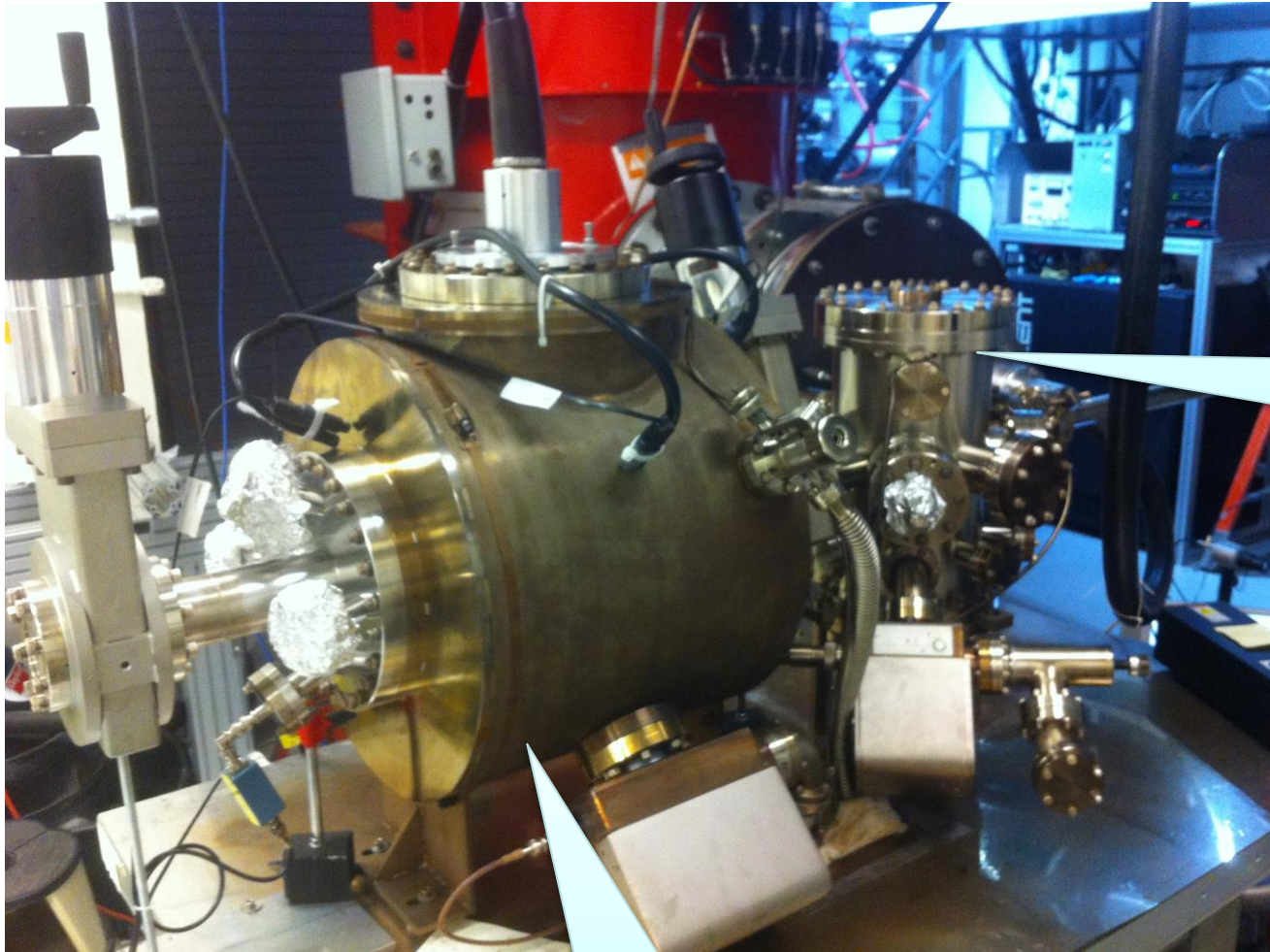

K₂CsSb
Preparation
Chamber

HV Chamber

Magnetic Field at Cathode

Beam radius	0.3 cm
Field at cathode (B_z)	2 kG

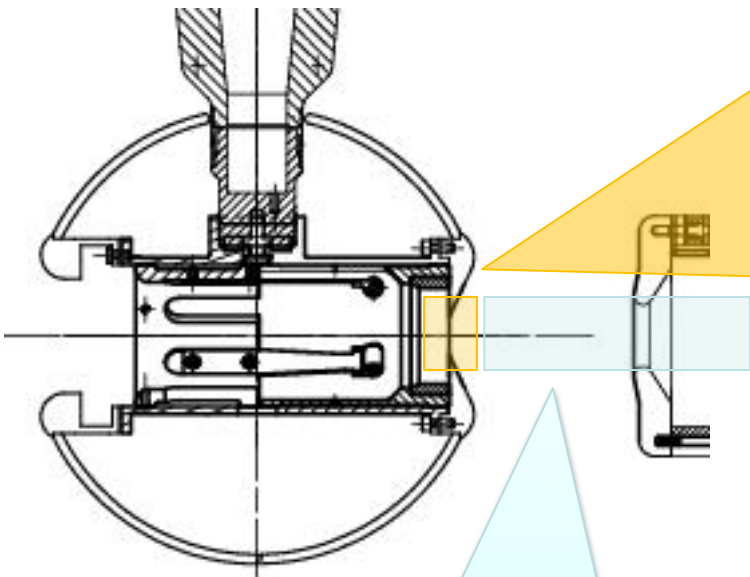

B_z, B_r : relevant to beam transport

Magnetization field (???):

- Along z:
 1. $B_z = 2$ kG
 2. Varying slowly to be able know value from S&A
- Along r:
 1. Radius = 0.5 cm
 2. Uniformity: $\frac{\delta B_z}{B_z} < 1\%$ (?)

HV Chamber

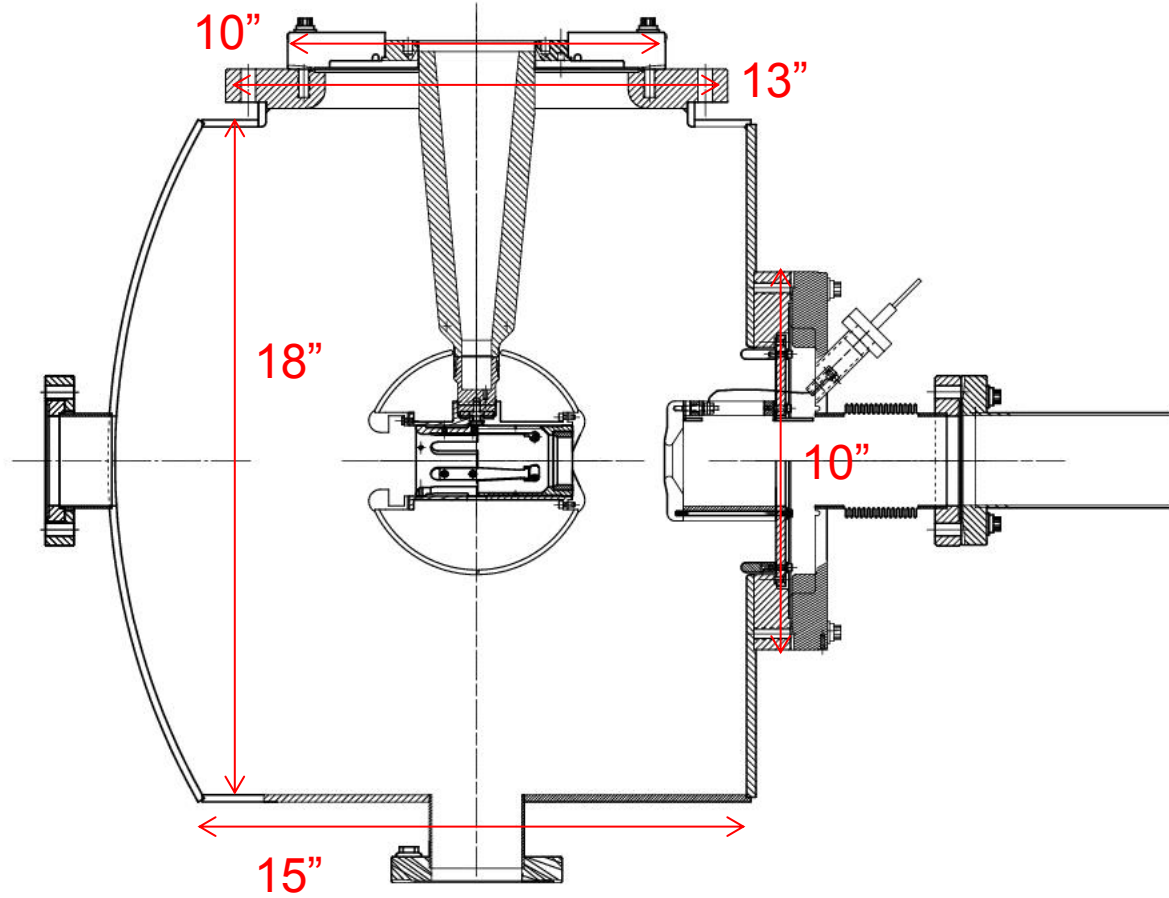

HV Chamber Clearance

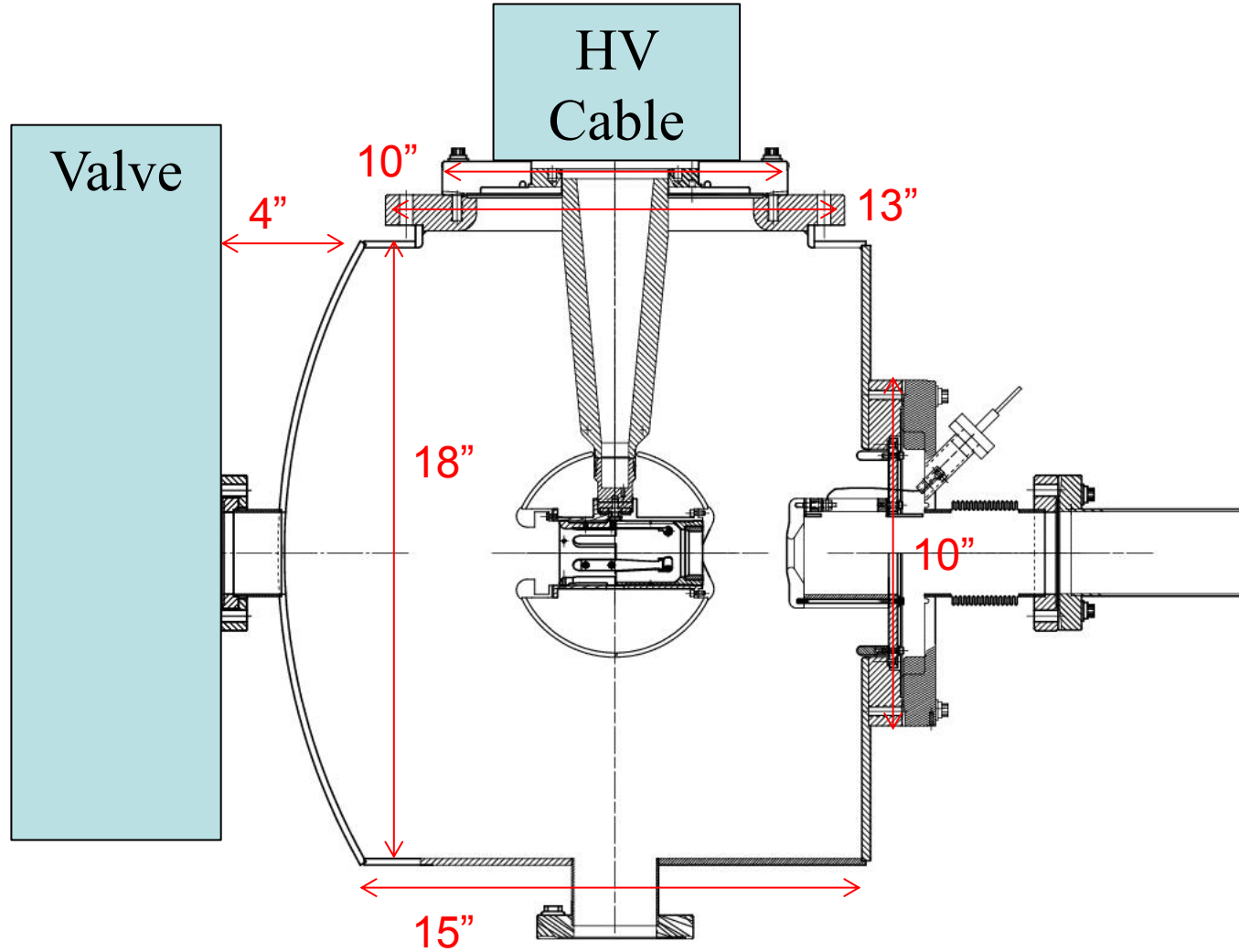

Design 2: Two coil Magnet

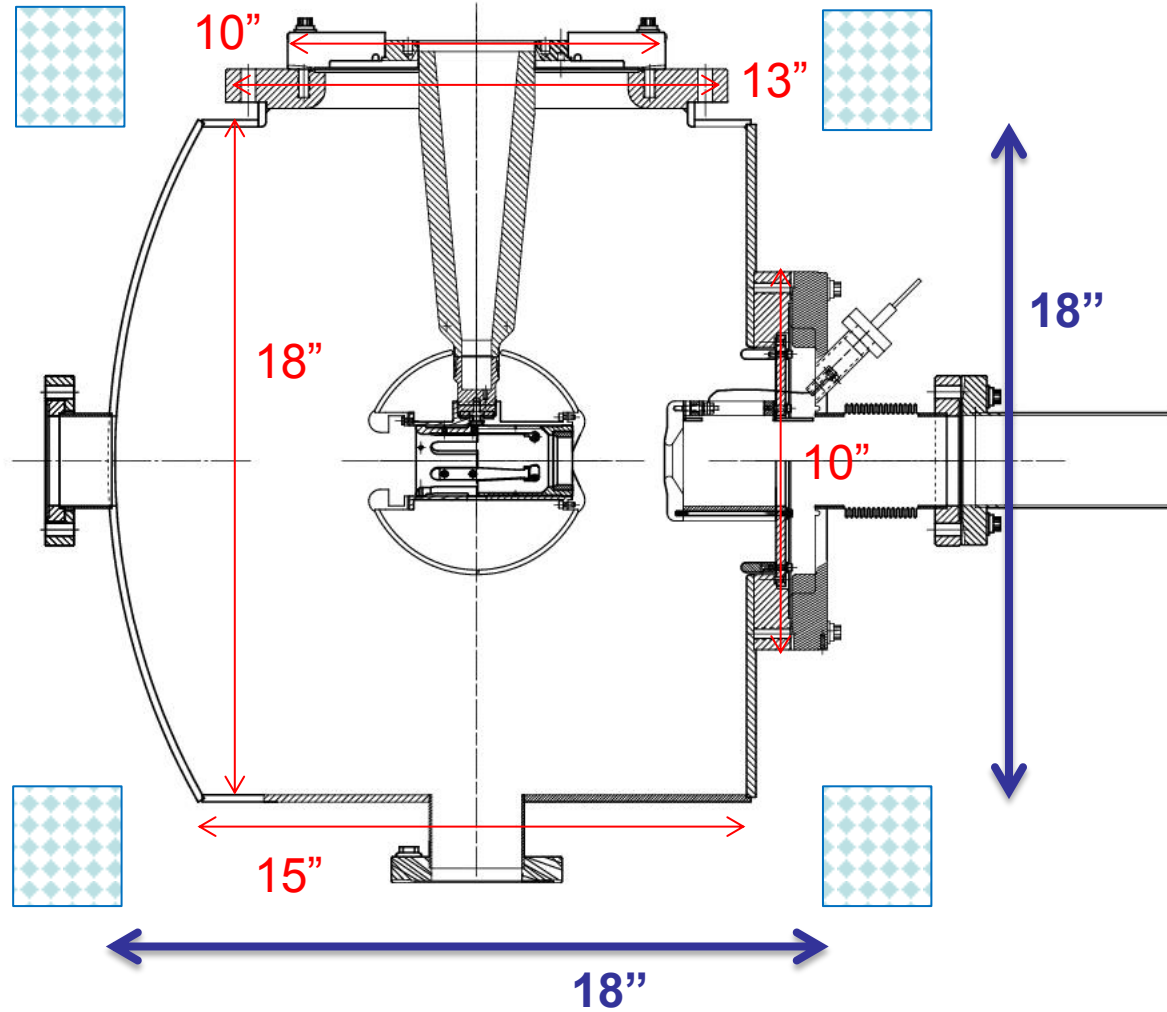

Design 3: One Solenoid + Steel Puck

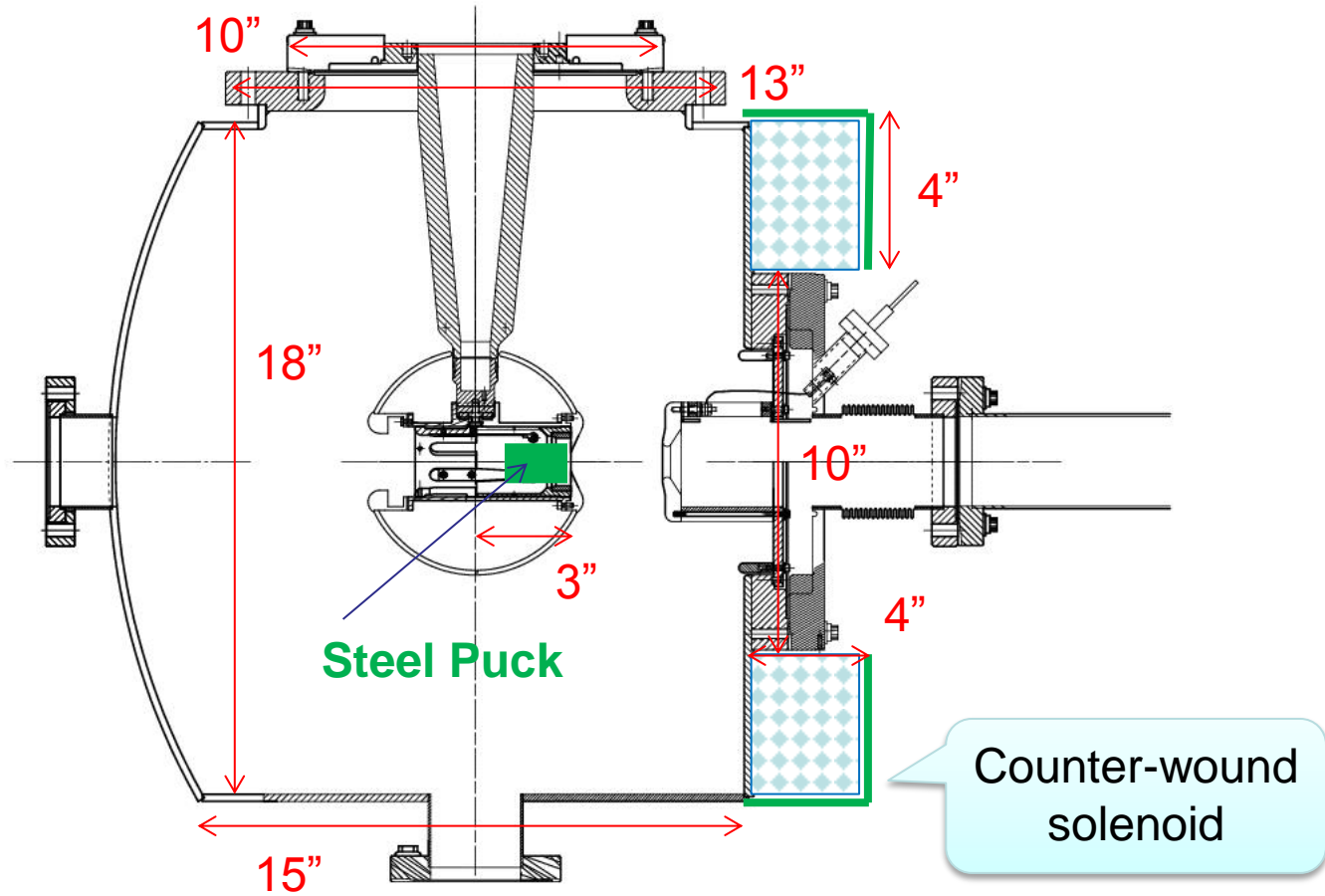

B_z vs z

