

Update on Development of High Current Bunched Electron Beam from Magnetized DC Photogun

JLEIC Collaboration Meeting
October 6, 2016

Riad Suleiman and Matt Poelker

Magnetized Cooling

- JLEIC bunched magnetized electron cooler is part of Collider Ring and aims to counteract emittance degradation induced by intra-beam scattering, to maintain ion beam emittance during collisions and extend luminosity lifetime.
- Electrons helical motion in strong magnetic field increases electron-ion interaction time, thereby significantly improving cooling efficiency. Electron-ion collisions that occur over many cyclotron oscillations and at distances larger than cyclotron radius are insensitive to electrons transverse velocity.
- Cooling rates are determined by electron longitudinal energy spread rather than electron beam transverse emittance as transverse motion of electrons is quenched by magnetic field
- This cyclotron motion also provides suppression of electron-ion recombination

Electron beam is being used inside cooling solenoid where it suffers an azimuthal kick when it enters. This kick is cancelled by an earlier kick at exit of cathode solenoid

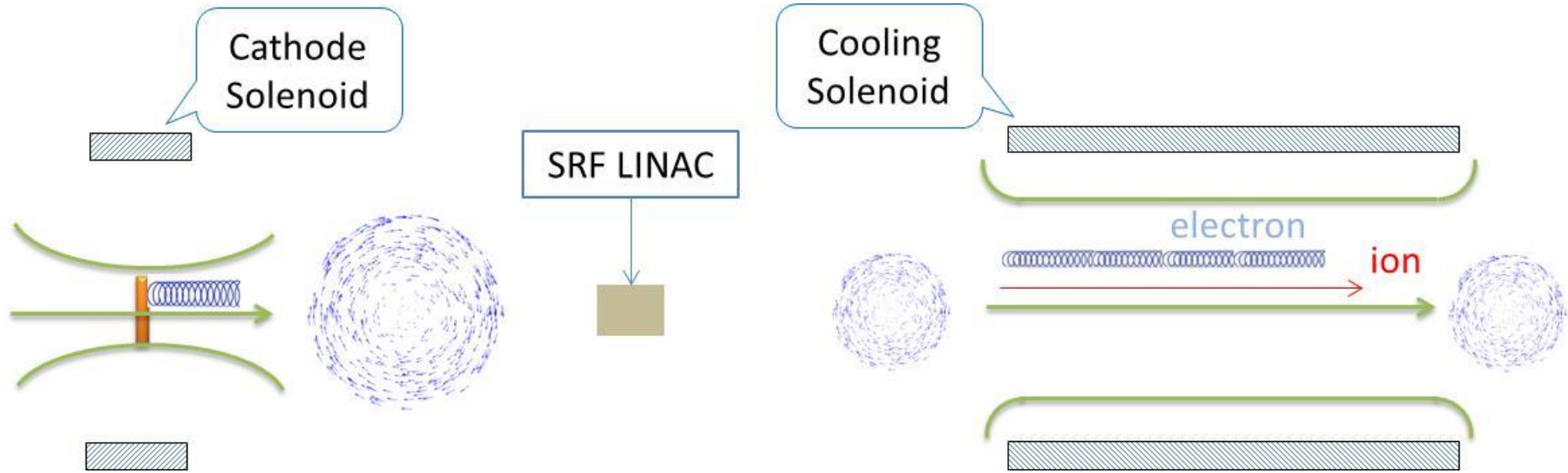

Electrons born in strong uniform B_z

$$\langle L \rangle = \frac{eB_z a_0^2}{4}$$

$$a_0 = R_{\text{laser}} = 1.56 \text{ mm}$$

$$B_z = 2 \text{ kG}$$

Upon exit of Cathode Solenoid

$$\langle L \rangle = \gamma m_e \langle r^2 \rangle \dot{\phi}$$

$$\varepsilon_d = \frac{eB_z a_0^2}{8m_e c} = 36 \text{ } \mu\text{m}$$

Upon entering Cooling Solenoid

$$\langle L \rangle = \frac{eB_{\text{cool}} r_e^2}{4}$$

$$\frac{B_{\text{cool}}}{B_z} = \frac{a_0^2}{r_e^2}$$

$$r_e = 0.7 \text{ mm}$$

$$B_{\text{cool}} = 1 \text{ T}$$

JLEIC Magnetized Beam LDRD

- Generate magnetized electron beam and measure its properties
- Explore impact of cathode solenoid on photogun operation
- Simulations and measurements will provide insights on ways to optimize JLEIC electron cooler and help design appropriate source
- JLab will have direct experience magnetizing high current electron beam

Magnetized Bunched Electron Beam Requirements

Bunch length	60 ps (2 cm)
Repetition rate	476.3 MHz
Bunch charge	420 pC
Peak current	7.0 A
Average current	200 mA
Transverse normalized emittance	10s microns
Cathode spot radius – Flat-top (a_0)	1.56 mm
Solenoid field at cathode (B_z)	2 kG

Experimental Overview

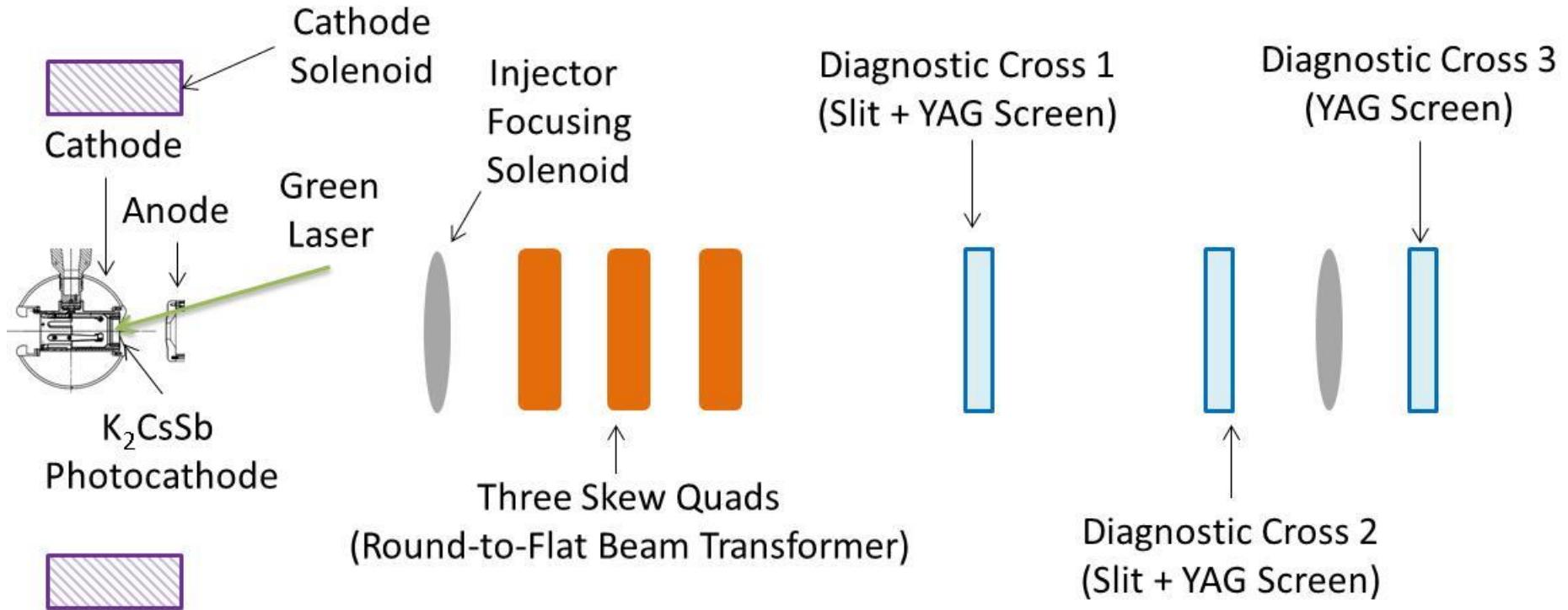

- Generate magnetized beam:
- $a_0 = 1 - 5$ mm, $B_z = 0 - 2$ kG
 - Bunch charge: 1 – 500 pC
 - Frequency: 15 Hz – 476.3 MHz
 - Bunch length: 10 – 100 ps
 - Average beam currents up to 32 mA
 - Gun high voltage: 200 – 350 kV

Planned Measurements

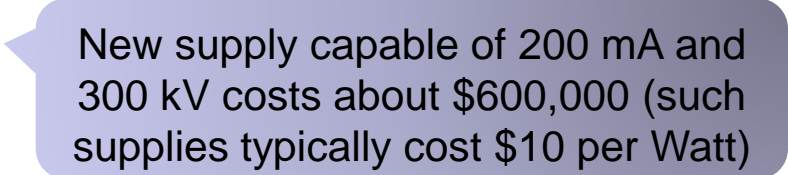
1. Measure mechanical angular momentum
2. Measure photocathode lifetime versus solenoid field at high currents (up to 32 mA) and high voltages (200 – 350 kV) limited by in-house HV supplies  New supply capable of 200 mA and 300 kV costs about \$600,000 (such supplies typically cost \$10 per Watt)
3. Study beam halo and beam loss versus magnetization
4. Use skew quads – RTFB Transformer – to generate flat beam and measure horizontal and vertical emittances using slit method
5. Generate very high currents magnetized beam and study beam transport and RTFB versus electron bunch charge

LERF Gun Test Stand

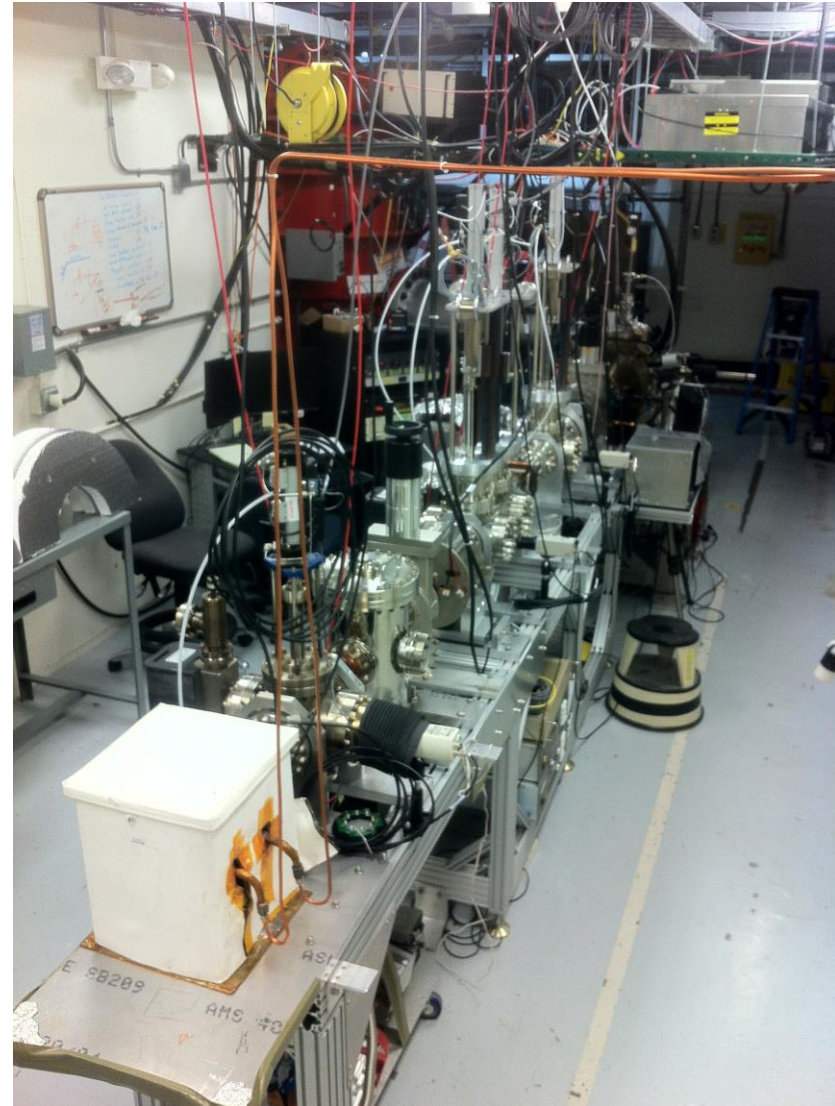
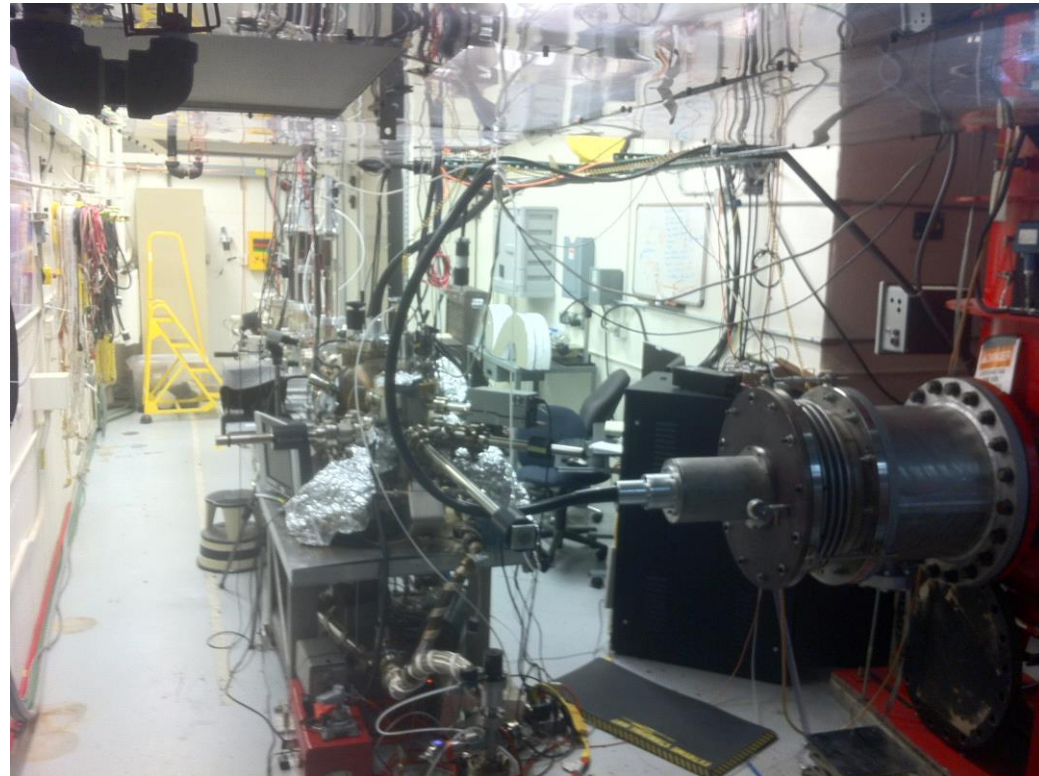

GTS Beam: 1 mA

300 kV
(not magnetized)

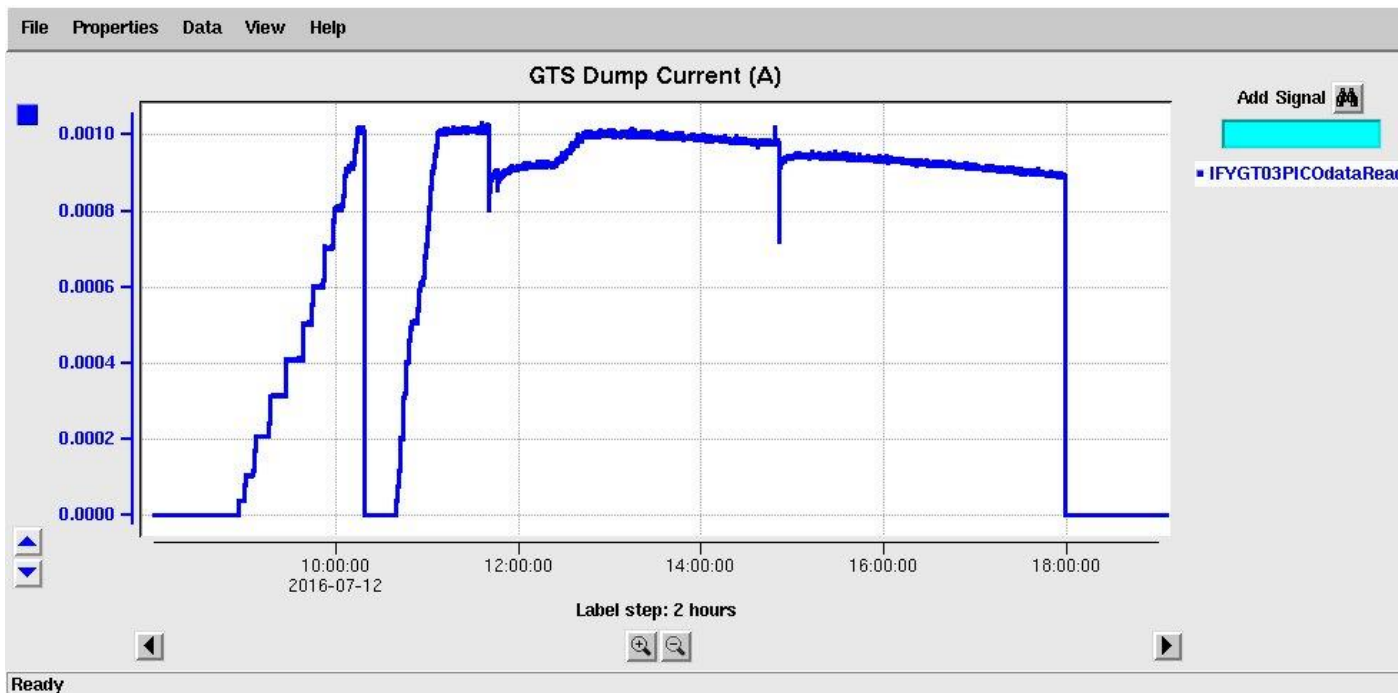
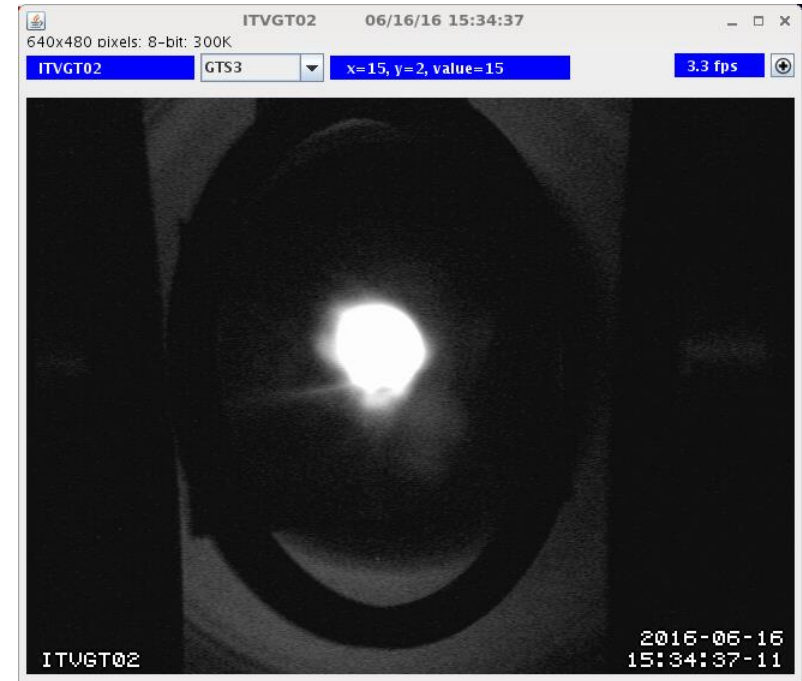

Prior Year Accomplishments

- K_2CsSb Photocathode Preparation Chamber, Gun and Beamline: delivered 1 mA to dump



- Gun Test Stand (GTS) OSP: approved for only 10 nA – working with Radiation Group for approval at full current
- Simulation (Fay Hannon):
 - Used ASTRA and GPT simulation to design beamline and to locate magnets and diagnostics at optimum positions
 - Simulated magnetized electron beam properties along beamline for various starting conditions
 - Simulated a round to flat transformer

- Cathode Solenoid Magnet

Size	11.811" ID, 27.559" OD, 6.242" Z
Conductor	L=500 m, A=0.53 cm ² 16 layers by 20 turns
Coil Weight	254 kg (560 lbs)
Resistance	0.183 Ω
Field at Photocathode	1.4 kG
Voltage	77 V
Current	400 A

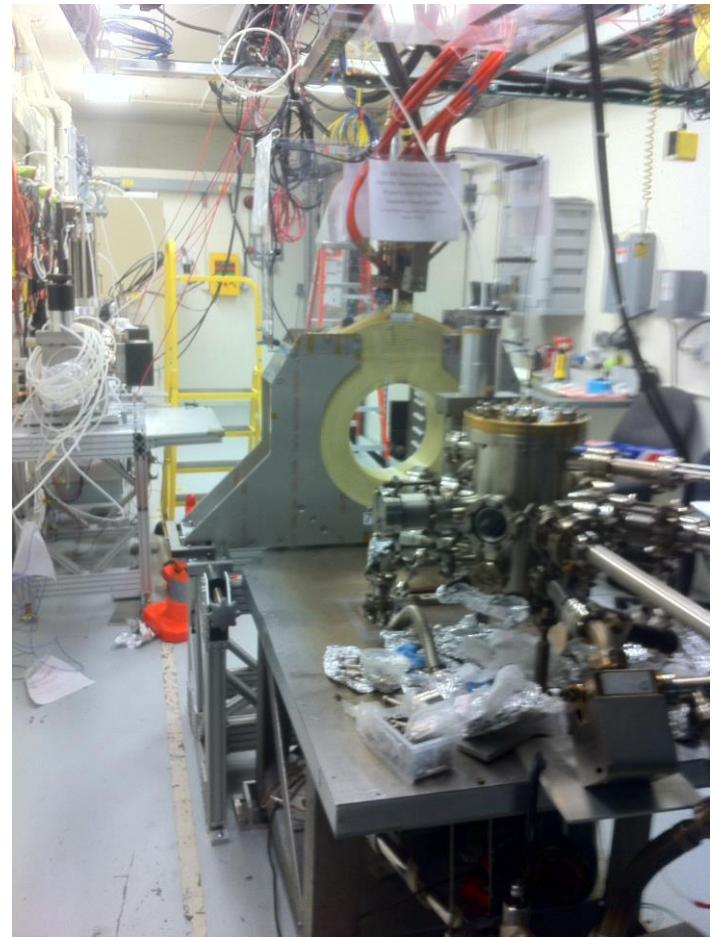

- Mapped and installed at GTS
- Cathode Solenoid Power Supply: Use new spare CEBAF Dogleg magnet power supply (500A, 80V)

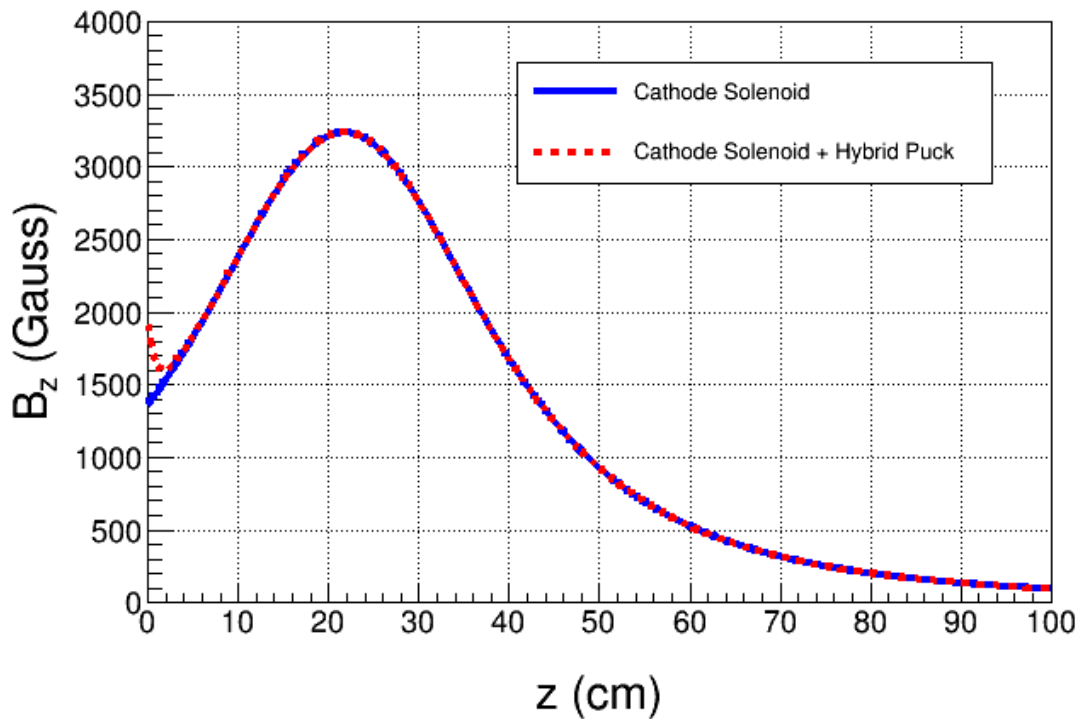

Molybdenum

Steel

Steel

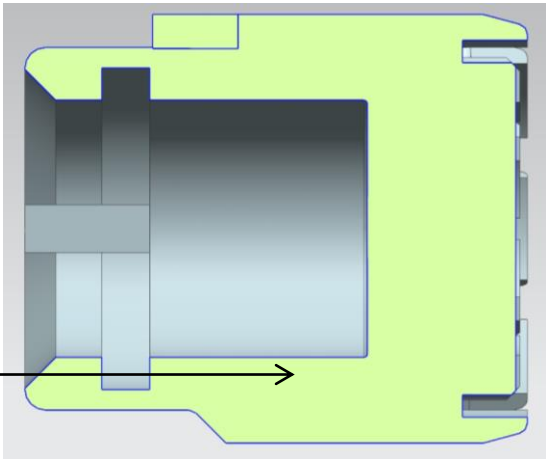
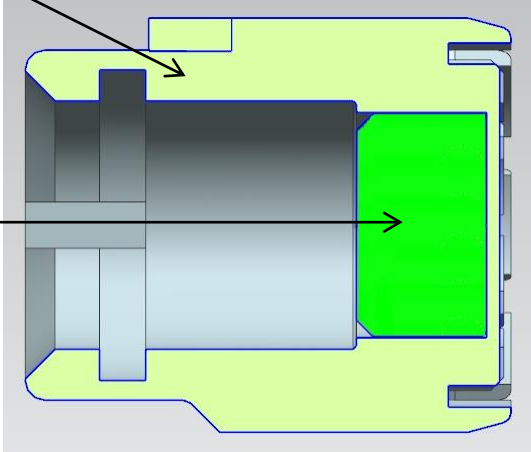

- New Steel Pucks

- Enhance field to 2.0 kG at cathode. Two types:
 - I. Molybdenum and carbon steel hybrid pock
 - II. Carbon steel pock

Plans October 2016

1. Upgrade Preparation chamber to enable K_2CsSb activation with a mask – limit photocathode active area to reduce beam halo
2. Load new pucks into Preparation Chamber
3. Upgrade HV Chamber with new ceramic insulator
4. Upgrade beamline and install slits and a Faraday Cup

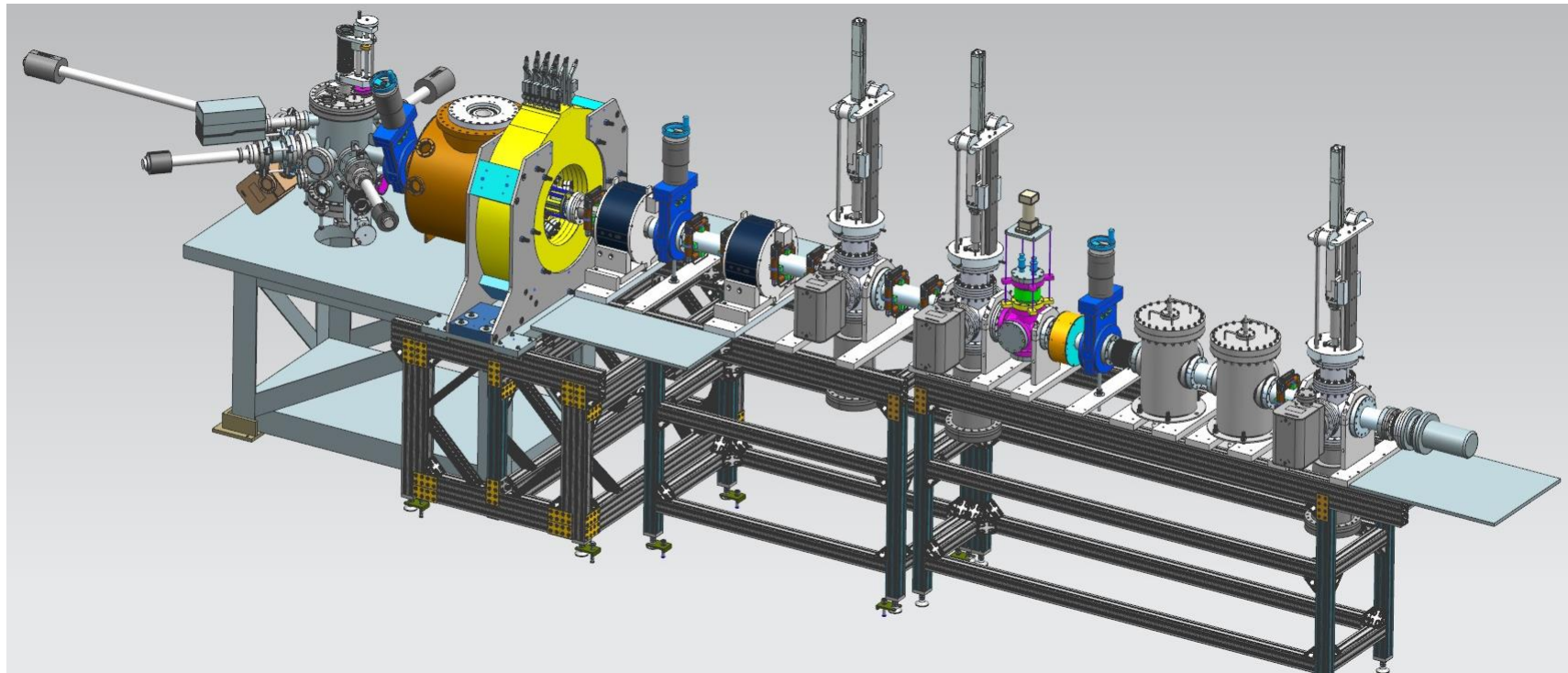
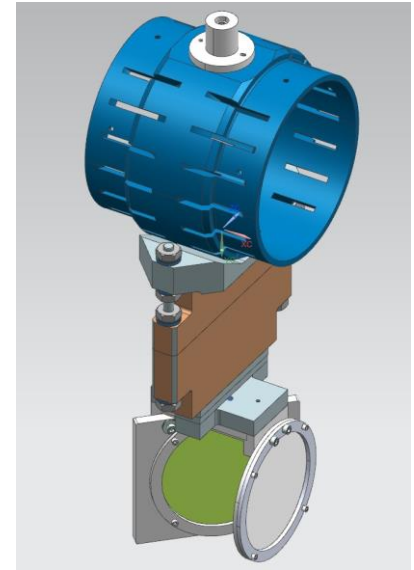

Budget

Materials and Supplies:

Funded

FY16	\$339,211
FY17	\$265,850
FY18	\$212,025
Total	\$817,086

1. Cathode solenoid magnet and pucks
2. Three skew quadrupoles
3. Beamline hardware: steering magnets and slits for beam emittance and magnetization measurements
4. Laser components

Labor:

1. Cathode magnet design and procurement
2. Cathode magnet mapping and installation
3. Relocate new CEBAF spare dogleg power supply (500A/80V) and provide 480VAC and LCW
4. Mechanical designer for cathode magnet support
5. Mechanical designer for pucks, slits and beamline
6. ASTRA and GPT modeling (Fay Hannon)
7. Postdoc – years 2 and 3

MILESTONES

Year 1 Milestones

- Q1 (Oct, Nov, Dec):
 1. HV condition gun to 350 kV and build K_2CsSb preparation chamber
 2. Design beamline, locate magnets and diagnostics at optimum positions
 3. Design cathode solenoid magnet
- Q2 (Jan, Feb, Mar):
 1. Connect existing beamline to gun and instrument beamline
 2. Procure cathode solenoid magnet
 3. Design and procure slits
- Q3 (Apr, May, Jun):
 1. Commission exiting beamline with beam
 2. Measure lifetime at ~~5~~ 1 mA and ~~350~~ 300kV (not magnetized)
 3. Relocate new spare CEBAF dogleg power supply to GTS
- Q4 (Jul, Aug, Sep):
 1. Install cathode solenoid magnet
 2. Assemble new beamline and commission with beam **October 2017**
 3. Design and procure three skew quads **Postponed to year 2**

Year 2 Milestones

- Q1 (Oct, Nov, Dec):
 1. Generate magnetized beam
 2. Measure mechanical angular momentum vs magnetization and laser size
 3. Benchmark simulation against measurements
- Q2 (Jan, Feb, Mar):
 1. Measure mechanical angular momentum vs bunch charge and bunch length
 2. Benchmark simulation against measurements
- Q3 (Apr, May, Jun):
 1. Generate very high currents magnetized beam and study beam transport vs electron bunch charge
- Q4 (Jul, Aug, Sep):
 1. Measure photocathode lifetime vs magnetization at 5 mA and 350 kV
 2. Study beam halo and beam loss vs magnetization

Year 3 Milestones

- Q1 (Oct, Nov, Dec):
 1. Install three skew quads
 2. Generate flat beam with skew quads – RTFB Transformer – and measure horizontal and vertical emittances using slit method
- Q2 (Jan, Feb, Mar):
 1. Measure RTFB transformation versus electron bunch charge
 2. Use simulation to quantify how good or complete RTFB transform
- Q3 (Apr, May, Jun):
 1. Change to HV Supply of 32 mA and 200 kV
- Q4 (Jul, Aug, Sep):
 1. Measure photocathode lifetime vs magnetization at 32 mA and 200 kV
 2. Study beam halo and beam loss vs magnetization