

SECTION A-A
SCALE 2 : 1

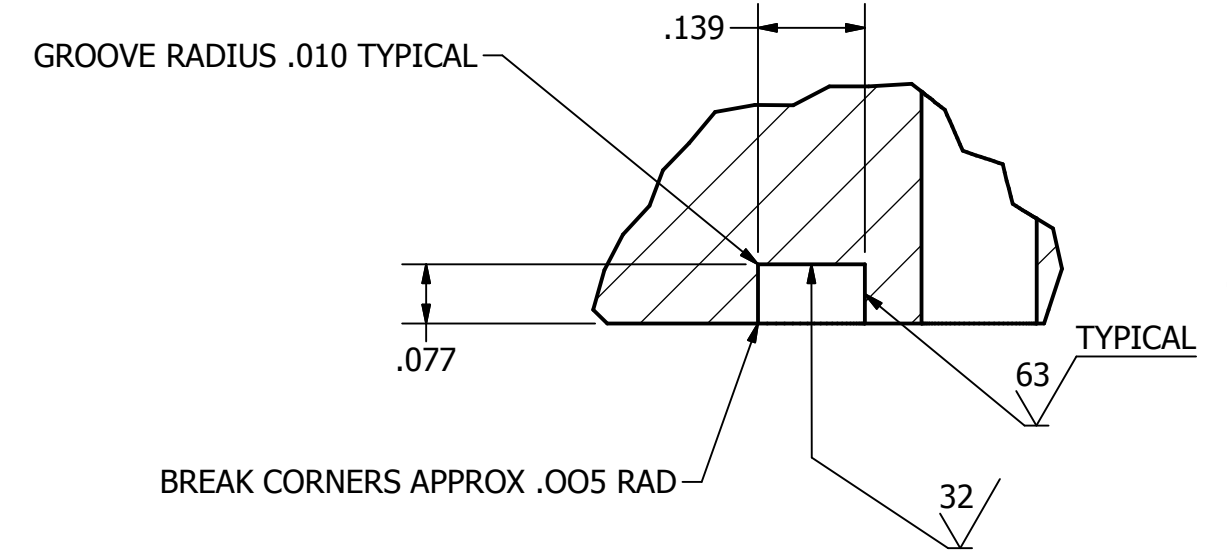
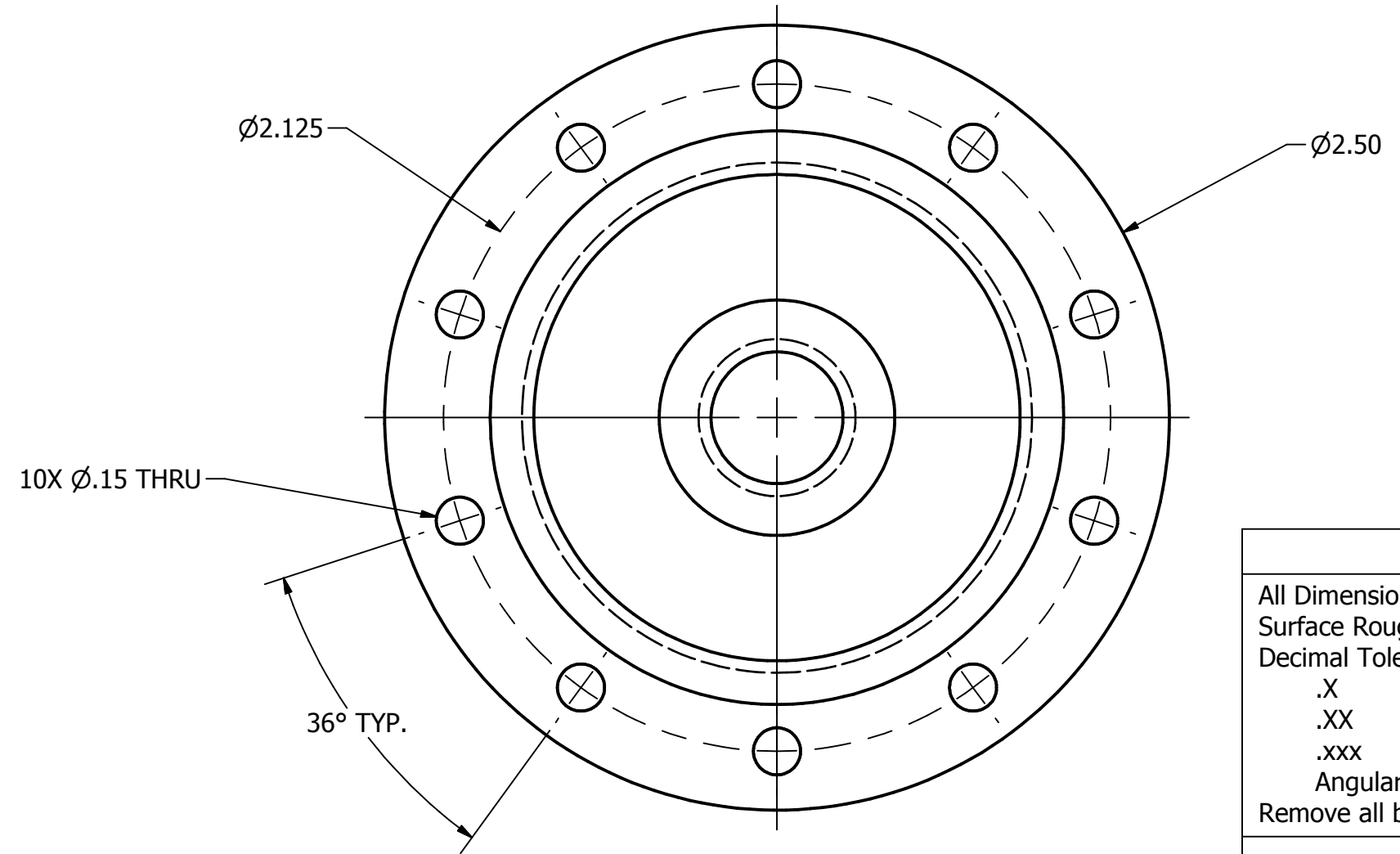

DETAIL B
SCALE 4 : 1

QTY. 2

Unless Otherwise Noted		DRAWN B. DiGiovine	8/19/2011	ARGONNE NATIONAL LABORATORY	
All Dimensions - Inches		CHECKED		TITLE	
Surface Roughness - 125		QA		GAMMA BEAM WINDOW	
Decimal Tolerance		MFG		SIZE	DWG NO
.X +/- .1		APPROVED		C	NPD-20-011
.XX +/- .01				SCALE	REV
.xxx +/- .003				2:1	
Angular Tol. +/- 1/4 deg.					
Remove all burrs and break sharp edges .03 max					
Material OFHC COPPER					SHEET 1 OF 1