

NOTES:

1 MDC VACUUM PROD. INC.
(OR CERAF APPROVED EQUIV)
23842 CABOT BLVD
HAYWARD CALIF. 94545-1651
TEL. 415-887-5100
800-443-8817

2 VACUUM GENERATORS INC.
SUITE 439G, 100 CUMMINGS CENTER
BEVERLY, MA 01915
TEL. 978-921-8885

3. USE THE FOLLOWING CERAF SPECS
FABRICATION OF UHV VACUUM EQUIPMENT ----- #22693-S-001
CLEANING & HANDLING OF UHV COMPONENTS ----- #22693-S-001
HELMHOLD LEAK TEST OF UHV COMPONENTS ----- #22694-S-001
QA REQUIREMENTS FOR BEAM TRANSPORT COMPONENTS ----- #9284-200-1

DIM 'A'	CONDITION
1.65"	APERTURE BLOCK AT MINIMUM HT.
1.77"	2mm APERTURE IN USE
2.16"	3mm APERTURE IN USE
2.56"	4mm APERTURE IN USE
3.62"	APERTURE BLOCK AT MAXIMUM HT.

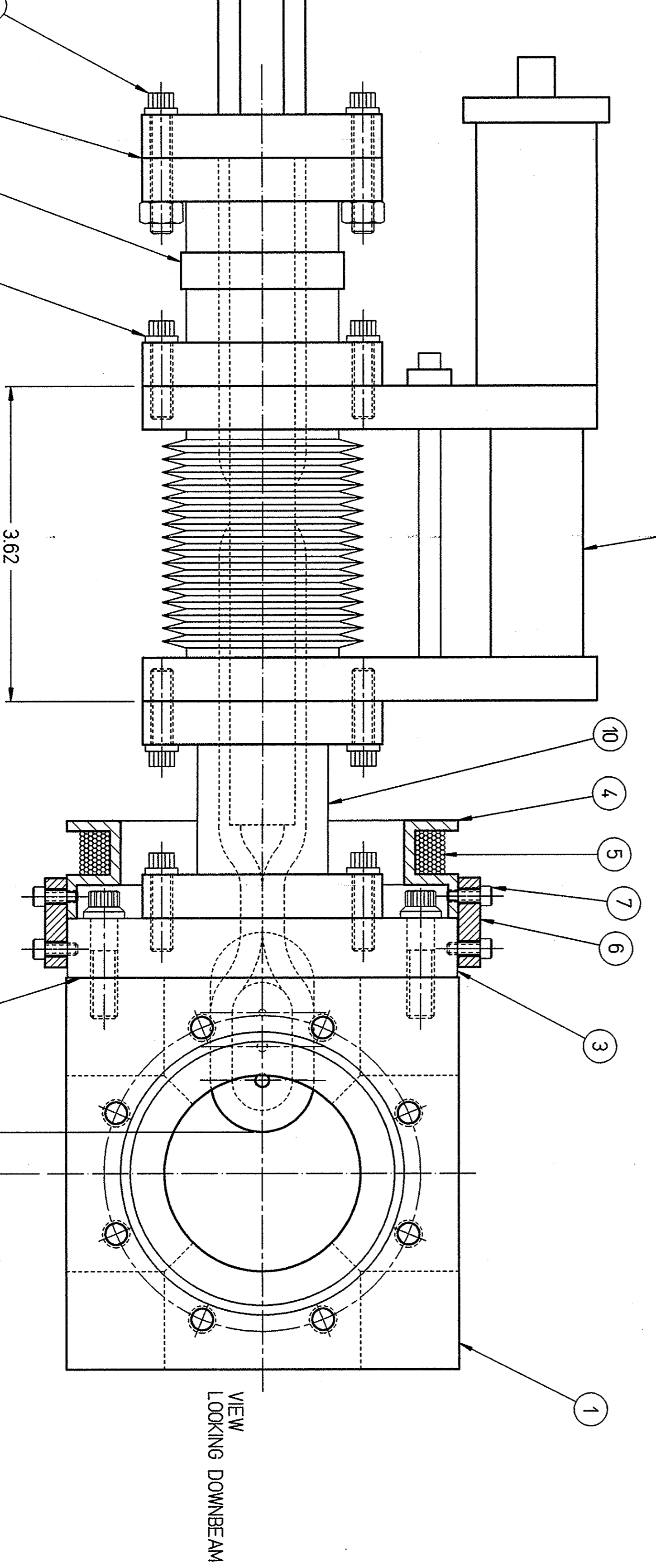
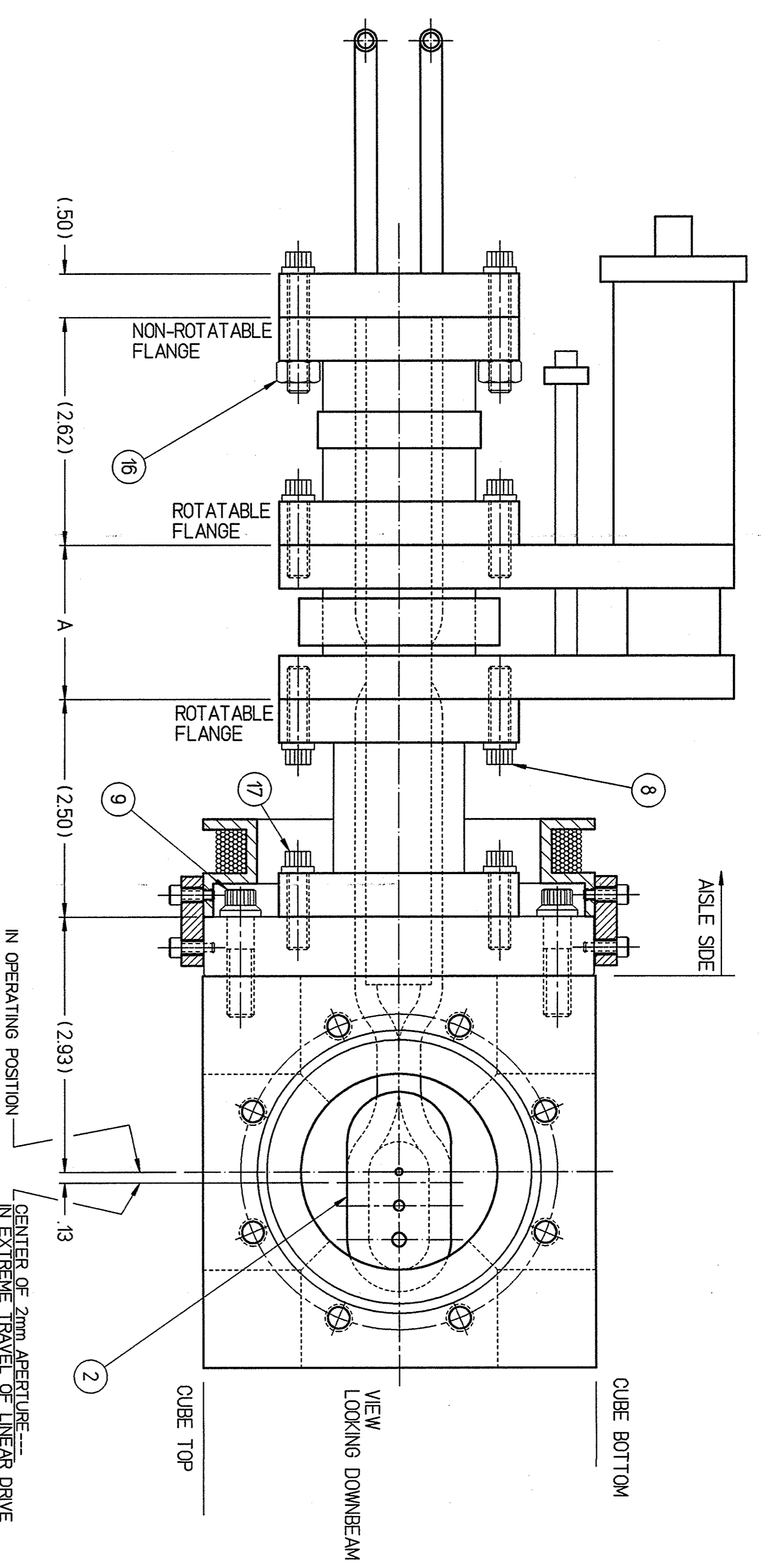

QTY	ITEM	PART OR IDENTIFYING NO.	DESCRIPTION	MATERIAL	NOTES
6	17		25-28 UNF X 875 LONG 12 PT HEAD BOLT WITH FLATWASHER	STAINLESS STEEL SILVER PLATED	
6	16		25-28 UNF HEX NUT	SILICON BRONZE	
1	15		4 1/2 CONEFLAT GASKET	SILVER PLATED COPPER	
4	14		2 3/4 CONEFLAT GASKET	SILVER PLATED COPPER	
6	13		25-28 UNF X 125 LONG 12 PT HEAD BOLT WITH FLATWASHER	STAINLESS STEEL	
1	12		CERAMIC BREAK		
1	11	VACUUM GENERATORS INC. ZLTN60	LINEAR TRANSFER MECHANISM		2
1	10	58432-B-0976	SPOOL		
8	9		3/2-24 UNF X 112 LONG 12 PT HEAD BOLT WITH FLATWASHER	STAINLESS STEEL SILVER PLATED	
12	8		M6 X 25mm 12PT HEAD BOLT WITH FLATWASHER	STAINLESS STEEL SILVER PLATED	
8	7		#6-32 UNC X .375 LONG SOCKET HEAD CAP SCREW	STAINLESS STEEL SILVER PLATED	
4	6	58432-B-0977	MAGNET RETAINING CLIP		
1	5		APERTURE #1 COIL WINDINGS	#16 GAUGE COPPER/KAPTON APPROX 60 TURNS	
1	4	39200-C-0213	APERTURE #1 COIL		
1	3	58432-B-0975	MODIFIED 4 1/2 ADAPTOR FLANGE		
1	2	58432-D-0965	APERTURE #1 SUB-ASSEMBLY		
1	1	MDC P/N 408003	6 WAY, 4 1/2" OF CUBE	(STAINLESS STEEL)	1

DM & TOP PER ASSEMBLY

APPROVED: *Thomas Jefferson National Accelerator Facility*

DATE: 2/14/02

SIZE/DWG. NO.: 58432-D-0974

DESIGNER & BREAK ALL SHARP EDGES

DO NOT SCALE DRAWING

REVISIONS

DATE APPROVED