

REVISIONS			
REV.	REMARKS	DRAWN	DATE

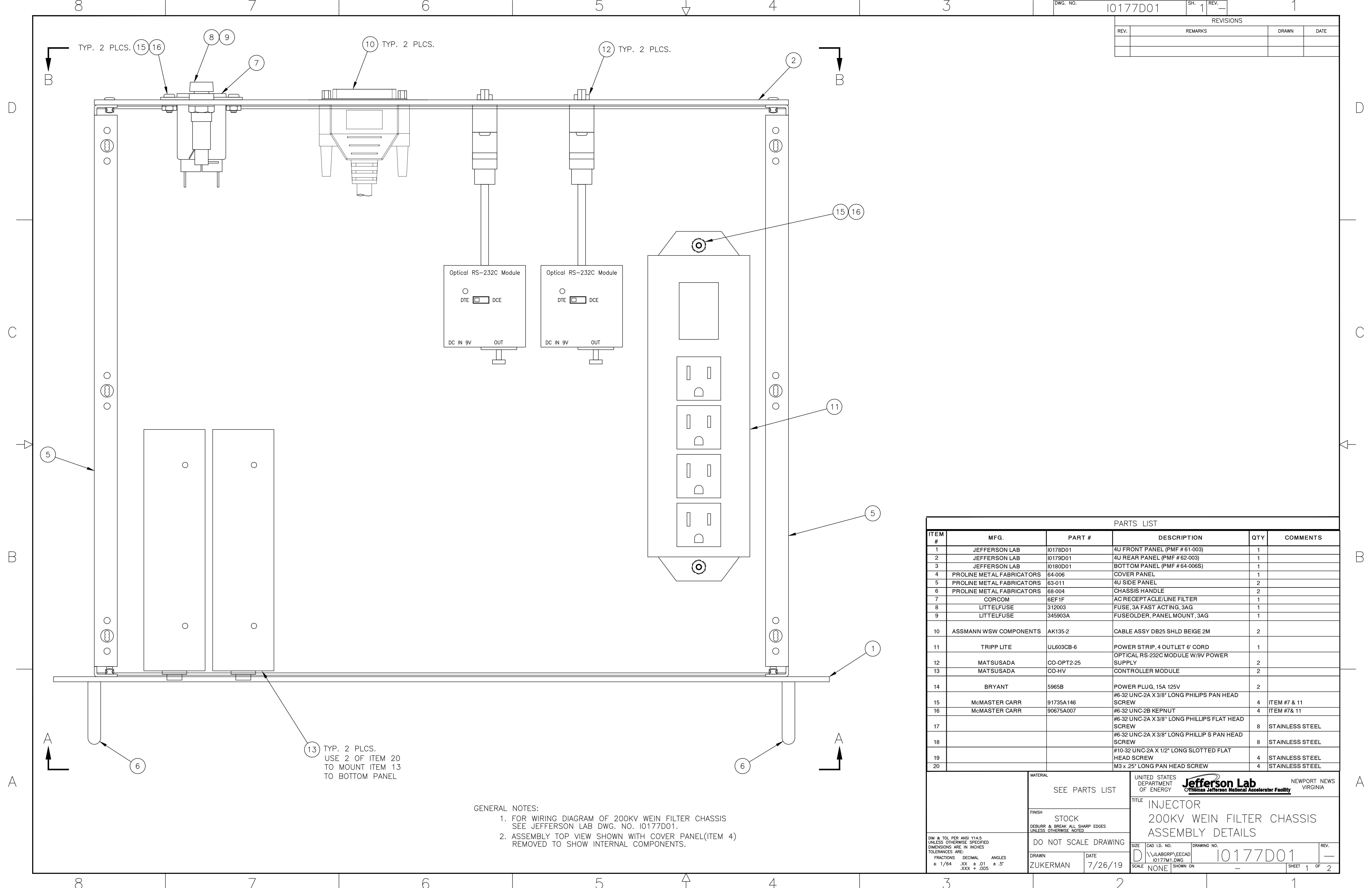

13 TYP. 2 PLCS.
USE 2 OF ITEM 20
TO MOUNT ITEM 13
TO BOTTOM PANEL

- GENERAL NOTES:
- FOR WIRING DIAGRAM OF 200KV WEIN FILTER CHASSIS SEE JEFFERSON LAB DWG. NO. I0177D01.
 - ASSEMBLY TOP VIEW SHOWN WITH COVER PANEL (ITEM 4) REMOVED TO SHOW INTERNAL COMPONENTS.

PARTS LIST					
ITEM #	MFG.	PART #	DESCRIPTION	QTY	COMMENTS
1	JEFFERSON LAB	I0178D01	4U FRONT PANEL (PMF # 61-003)	1	
2	JEFFERSON LAB	I0179D01	4U REAR PANEL (PMF # 62-003)	1	
3	JEFFERSON LAB	I0180D01	BOTTOM PANEL (PMF # 64-006S)	1	
4	PROLINE METAL FABRICATORS	64-006	COVER PANEL	1	
5	PROLINE METAL FABRICATORS	63-011	4U SIDE PANEL	2	
6	PROLINE METAL FABRICATORS	68-004	CHASSIS HANDLE	2	
7	CORCOM	6EF1F	AC RECEPTACLE/LINE FILTER	1	
8	LITTELFUSE	312003	FUSE, 3A FAST ACTING, 3AG	1	
9	LITTELFUSE	345903A	FUSEOLDER, PANEL MOUNT, 3AG	1	
10	ASSMANN WSW COMPONENTS	AK135-2	CABLE ASSY DB25 SHLD BEIGE 2M	2	
11	TRIPP LITE	UL603CB-6	POWER STRIP, 4 OUTLET 6' CORD	1	
12	MATSUSADA	CO-OPT2-25	OPTICAL RS-232C MODULE W/9V POWER SUPPLY	2	
13	MATSUSADA	CO-HV	CONTROLLER MODULE	2	
14	BRYANT	5965B	POWER PLUG, 15A 125V	2	
15	McMASTER CARR	91735A146	#6-32 UNC-2A X 3/8" LONG PHILIPS PAN HEAD SCREW	4	ITEM #7 & 11
16	McMASTER CARR	90675A007	#6-32 UNC-2B KEPNUT	4	ITEM #7 & 11
17			#6-32 UNC-2A X 3/8" LONG PHILLIPS FLAT HEAD SCREW	8	STAINLESS STEEL
18			#6-32 UNC-2A X 3/8" LONG PHILLIP S PAN HEAD SCREW	8	STAINLESS STEEL
19			#10-32 UNC-2A X 1/2" LONG SLOTTED FLAT HEAD SCREW	4	STAINLESS STEEL
20			M3 x 25" LONG PAN HEAD SCREW	4	STAINLESS STEEL

MATERIAL SEE PARTS LIST		UNITED STATES DEPARTMENT OF ENERGY Jefferson Lab Thomas Jefferson National Accelerator Facility NEWPORT NEWS VIRGINIA	
FINISH STOCK DEBURR & BREAK ALL SHARP EDGES UNLESS OTHERWISE NOTED		TITLE INJECTOR 200KV WEIN FILTER CHASSIS ASSEMBLY DETAILS	
DO NOT SCALE DRAWING		DRAWING NO. I0177D01	
DRAWN ZUKERMAN	DATE 7/26/19	SCALE NONE	REV. -
DIM & TOL PER ANSI Y14.5 UNLESS OTHERWISE SPECIFIED DIMENSIONS ARE IN INCHES TOLERANCES ARE: FRACTIONS DECIMAL ANGLES ± 1/64 .XX ± .01 ± .5° .XXX ± .005		SHEET 1 OF 2	

D

D

C

C

B

B

A

A

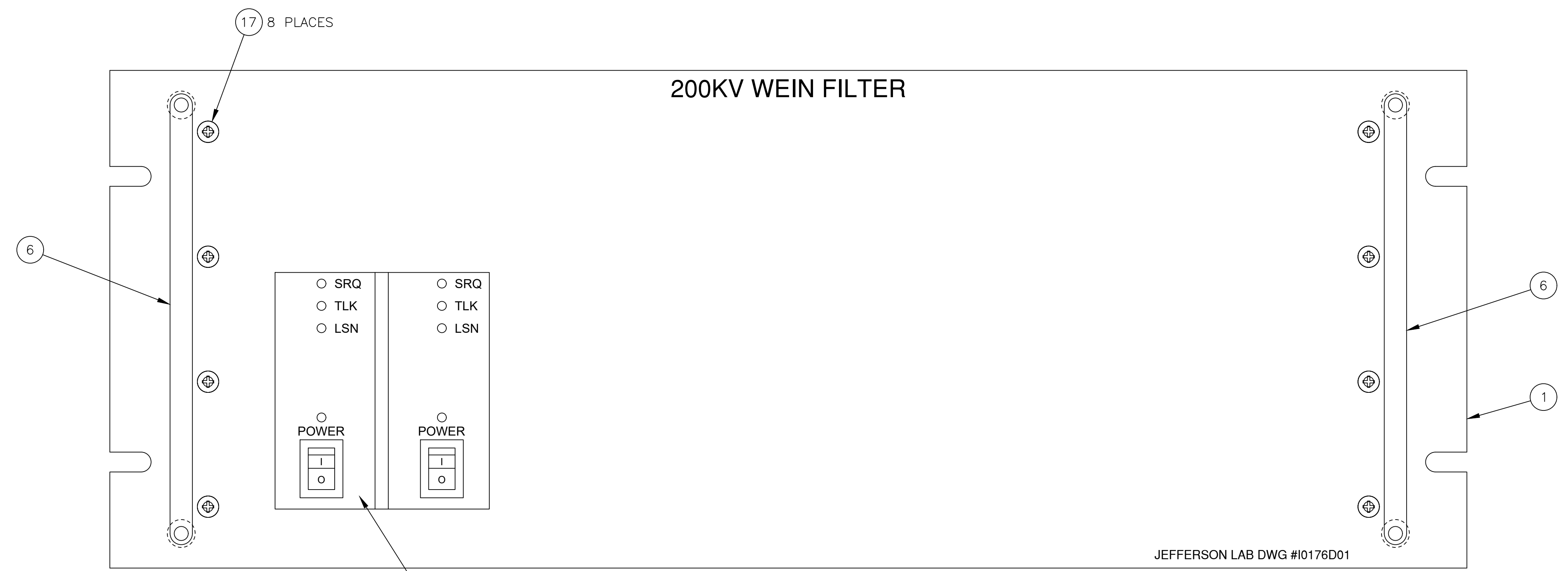

JEFFERSON LAB DWG #I0176D01

13 TYP. 2 PLCS.
USE 2 OF ITEM 20
TO MOUNT ITEM 13
TO BOTTOM PANEL

VIEW A-A

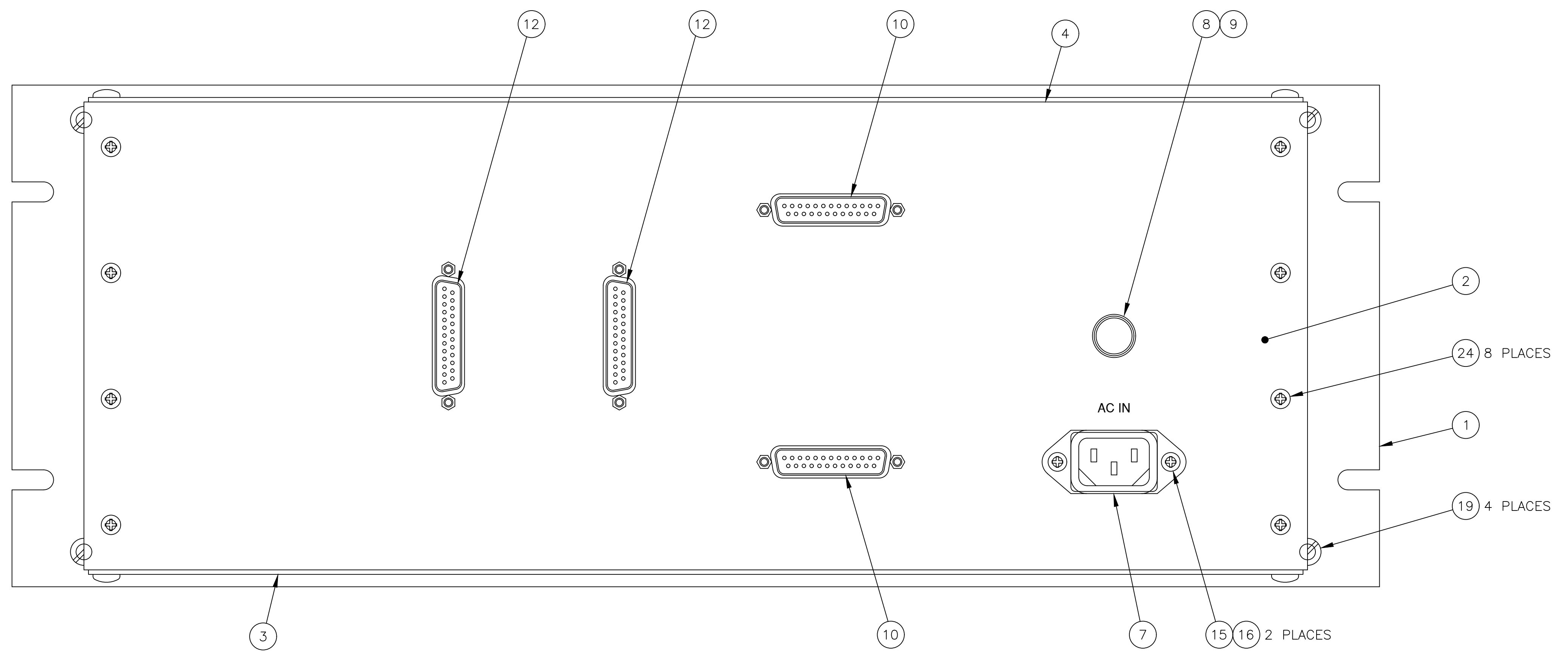

VIEW B-B

INJECTOR- 200KV WEIN FILTER			
CHASSIS ASSEMBLY DETAILS			
SIZE	CAD I.D. NO.	DRAWING NO.	REV.
D	LABGRP\EECAD	I0177D01	-
SCALE	SHOWN ON	SHEET	OF
NONE		2	2