

REVISION HISTORY			DATE	APPROVED
ZONE	REV	DESCRIPTION		

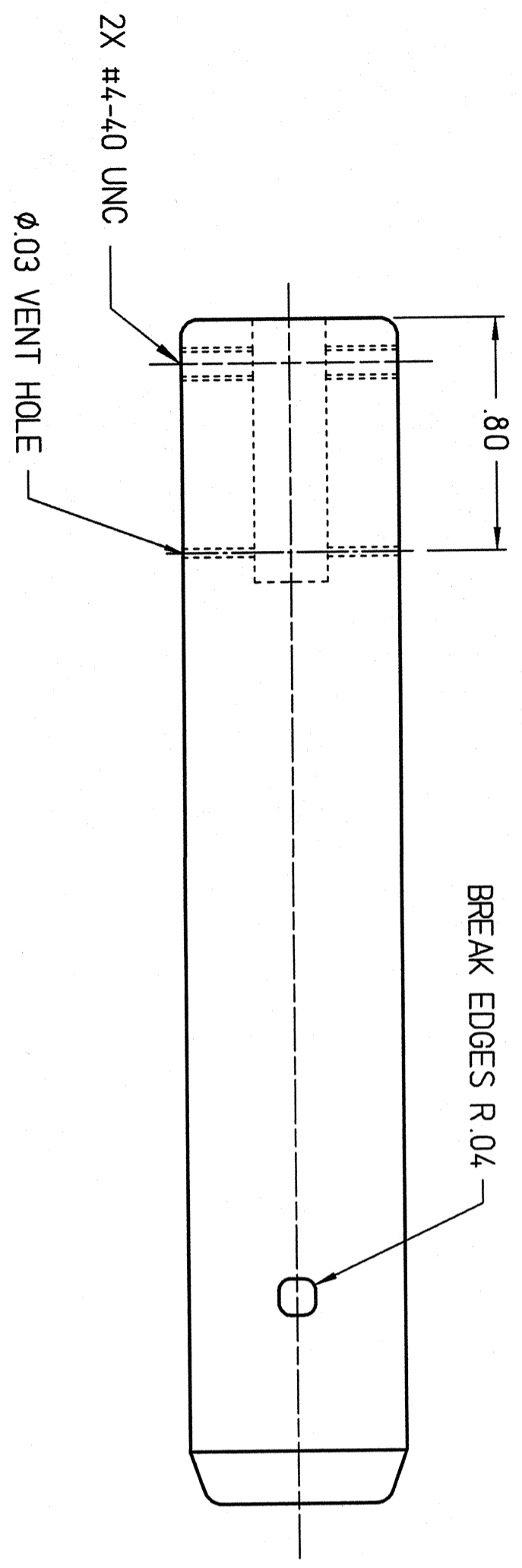
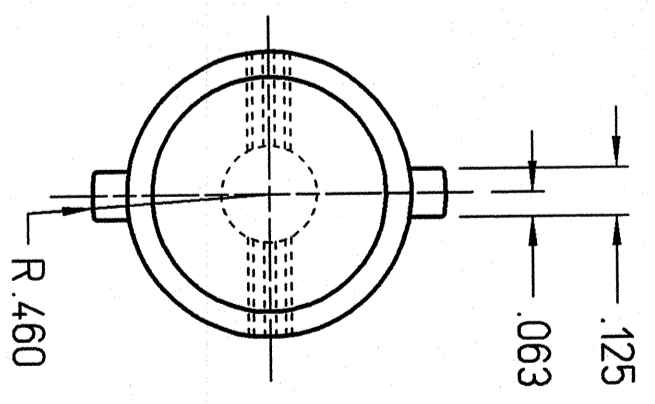
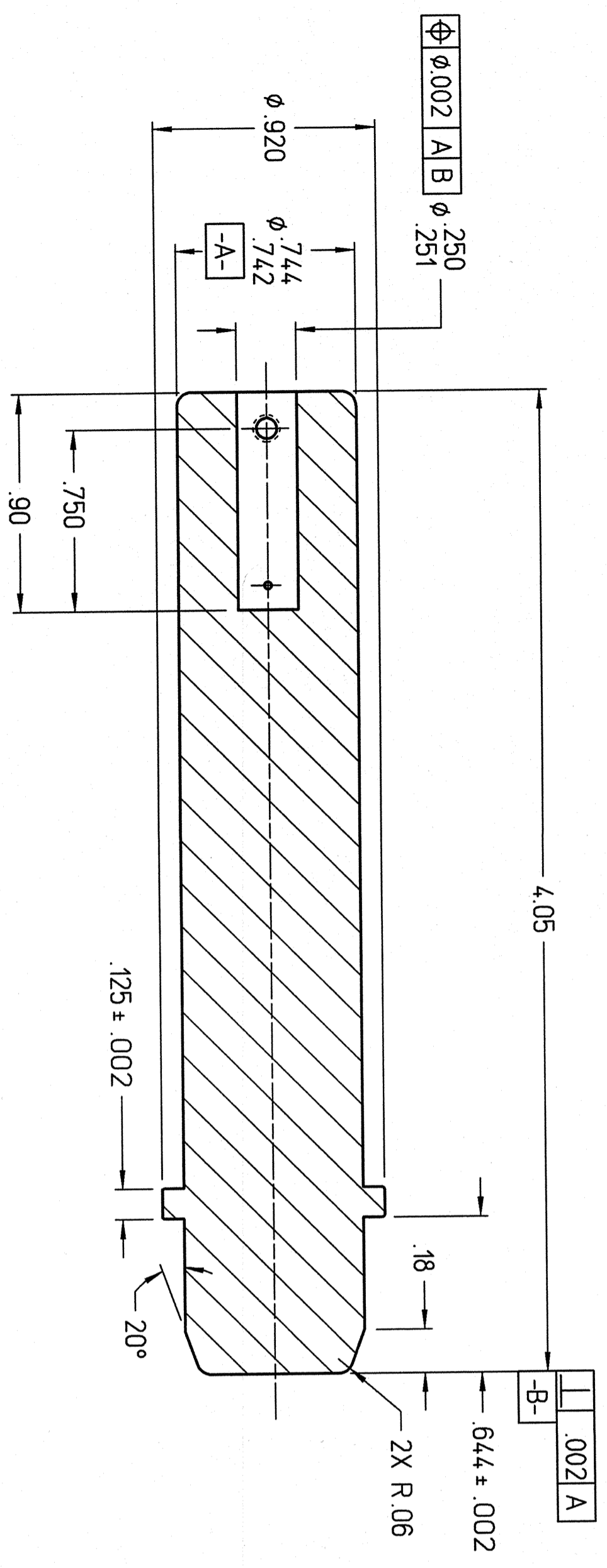

NOTES:

1. USE THE FOLLOWING C.E.B.A.F. SPECIFICATIONS FABRICATION OF ULTRA HIGH VACUUM EQUIPMENT: CLEANING AND HANDLING OF U.H.V. COMPONENTS: #22631-S-001 #22632-S-001
2. SILVER PLATE PART .0002 THICK

DOCUMENT CONTROL STAMP		QTY		ITEM	PART OR IDENTIFYING NO.	NOMENCLATURE OR DESCRIPTION		MATERIAL SPECIFICATION	NOTES
304 STAINLESS STEEL		RECD	NO.			PARTS LIST			
FINISH: MACHINED SURFACES DEBURR & BREAK ALL SHARP EDGES		DIM & TOL PER ASME Y14.5 UNLESS OTHERWISE SPECIFIED DIMENSIONS ARE IN INCHES TOLERANCES ARE: FRACTIONS DECIMAL ANGLES		THIRD ANGLE PROJECTION		APPROVALS		TRACKING NO. N/A	
UNLESS OTHERWISE NOTED		X.XX ± .01		X.XXX ± .005		DRAWN		DATE	
DO NOT SCALE DRAWING		50°		APPROVED		D. MACHE		03OCT06	
		CHECKED		APPROVED		DATE		11/15/06	
		APPROVED		APPROVED		DATE		11/30/06	
		SCALE		SIZE		DWG. NO.		ACC-200-3000-0219	
		2:1		C		SHEET		1 OF 1	