Ln2 Pre-cooling/ 2K System processes/ Typical Components

By

VenkataRao Ganni

March 8, 2011



Operated by the Jefferson Science Associates for the U.S. Dept. of Energy



Office of Science
U.S. Department of Energy

Tentative Schedule

Chapter		Duration (min)
•	<u>0 Questions on earlier materials</u>	<u>5</u>
•	<u>6 Liquid Nitrogen Pre-cooling</u>	<u>25</u>
•	<u>7 Sub-Atmospheric {2-K} Helium Refrigeration Systems</u>	<u>25</u>
•	<u>8 Typical Helium Cryogenic System and Basic Components</u>	<u>25</u>
•	<u>Discussions</u>	<u>?</u>



Operated by the Jefferson Science Associates for the U.S. Dept. of Energy



6. Liquid Nitrogen Pre-cooling

Liquid nitrogen (LN₂) pre-cooling is widely used in helium refrigeration systems. We would like to...

- Discuss the advantages and drawbacks of using LN₂ pre-cooling
- Discuss and explain various LN₂ pre-cooling schemes used
- Provide some simplified analyses

Objective: provide a rational viewpoint for using LN₂ pre-cooling and the methods to both minimize LN₂ consumption and required equipment capital cost while reducing the dangers of LN₂ freezing and achieving an optimized design



Liquid Nitrogen Pre-cooling (Cont.)

What Does LN₂ Pre-Cooling Do?

In steady state operation of helium refrigeration systems, LN₂ pre-cooling provides :

- The liquefaction load flow unbalance, i.e., to cool the net helium make-up gas from 300 to 80K, ~3 g/s of LN₂ per 1 g/s of makeup helium is required
- The 300-80K heat exchanger (HX-1) cooling curve losses due to stream temperature difference (ΔT 's) associated with the recycled compressor flow



Liquid Nitrogen Pre-cooling (Cont.)

What Does LN₂ Pre-Cooling Do? (Continued)

- Provides the refrigeration for these needs at an operating efficiency close to that of an LN₂ plant
- Used to increase system capacity by providing refrigeration that would otherwise be required from the existing turbines, allowing them to operate at a lower temperature, so that the refrigeration they are providing is at a higher Carnot (exergetic) value.



Operated by the Jefferson Science Associates for the U.S. Dept. of Energy



Carnot Helium Refrigeration and Liquefaction Systems (Cont)

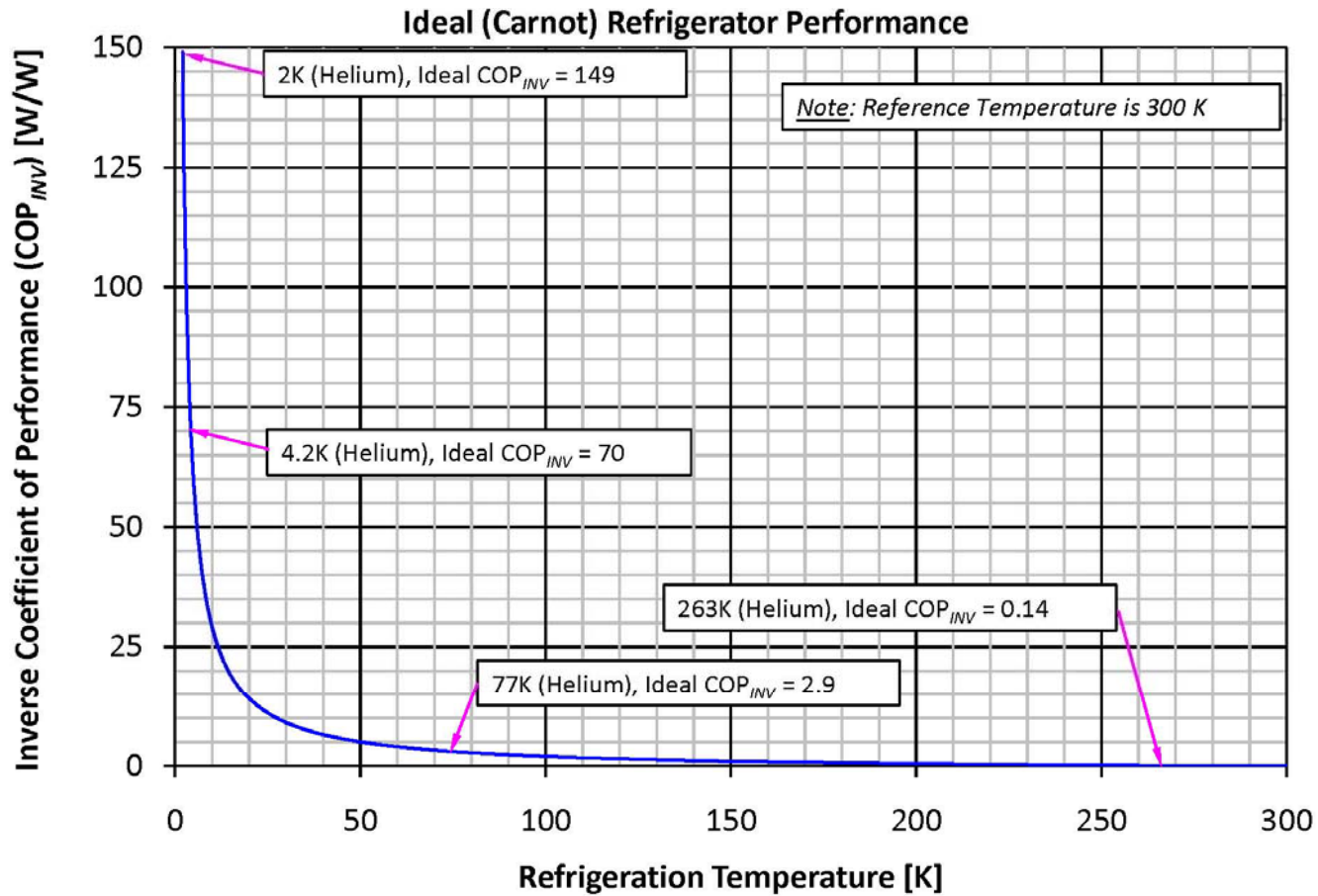

	T_{load} (K)	P_{carnot} W / W
A / C Sys.	263.0	0.14
Methane	111.7	1.69
Oxygen	90.2	2.33
Argon	87.3	2.44
Nitrogen	77.3	2.88
Neon	27.1	10.07
Hydrogen	20.3	13.79
Helium	4.2	70.09
Helium @ Lambda	2.2	137.25
Helium @ 2.0 K	2.0	149.00



Operated by the Jefferson Science Associates for the U.S. Dept. of Energy



Carnot Helium Refrigeration and Liquefaction Systems (Cont)

**Carnot work required for liquefaction
load for a given temperature range**

Temperature	$T_0 * \Delta s$	%	Δh	%	$T_0 * \Delta s - \Delta h$	%
Range (K)	[W/ (g/s)]		[W/ (g/s)]		[W/ (g/s)]	
300 - 80	2058	24.5%	1143	73.0%	915	13.4%
80 - 4.22	6329	75.5%	421	27.0%	5908	86.6%
300 - 4.22	8387	100.0%	1569	100.0%	6823	100.0%



Liquid Nitrogen Pre-cooling (Cont.)

Advantages of using LN₂:

- **A lower capital investment for a given refrigeration capacity**
 - increases the LHe production or the refrigeration capacity by 1.5 times or more
- **A smaller cold box and compressor size for a given capacity requires a smaller building. Space is also required for a LN2 dewar - located outside**
- **Provides a thermal anchor point for the 80K adsorber beds and the refrigeration capacity to re-cool the beds after regeneration**
- **Stable operation over a larger operating range and a larger refrigeration turndown capability**
- **Has fewer rotating parts and lower maintenance costs for a given capacity**
- **Able to keep the load temperature at 80K during partial maintenance of the cold box sub- systems (i.e., turbine replacement, etc.)**
- **Impurities in the helium stream are frozen in the 'warm' HX and thereby protecting the lower temperature turbines from contamination and erosion damage.**
- **Extremely useful to handle the cool down of especially large loads. In general, approximately ~80% of the LHe temperature cool down load is from 300K to 80K**



Liquid Nitrogen Pre-cooling (Cont.)

Disadvantages of using LN₂:

- Operating costs are typically greater (depends upon local electrical power cost vs. LN₂ cost)
- Presence of different fluids in the system, thereby presenting the potential for cross fluid leaks than can result in plugging and capacity loss (due to the increased pressure drop).
- Requires the coordination of LN₂ deliveries (although, this can be automated by the supplier)
- Weather constrains (winter road conditions and the summer power restrictions) may affect the LN₂ deliveries
- LN₂ operations in enclosures are generally more hazardous than LHe operations in enclosures and requires additional oxygen deficiency hazard (ODH) monitoring.



Liquid Nitrogen Pre-cooling (Cont.)

LN₂ Pre-cooling Types

- Different types of HX arrangements used for LN₂ pre-cooling have a major influence on the size of the HX's and the required LN₂ consumption.
- Six commonly used types
Type-1 through Type-6
are examined for comparison.



Operated by the Jefferson Science Associates for the U.S. Dept. of Energy



Liquid Nitrogen Pre-cooling (Cont.)

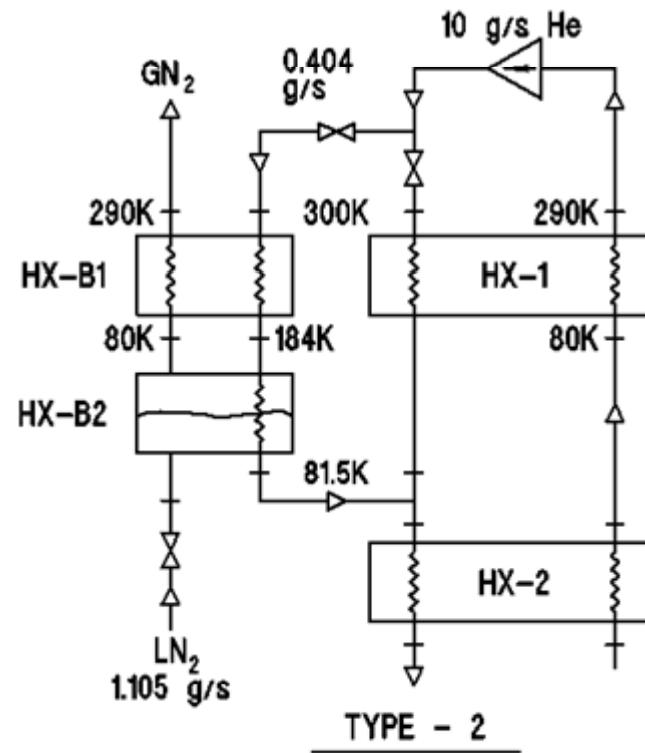
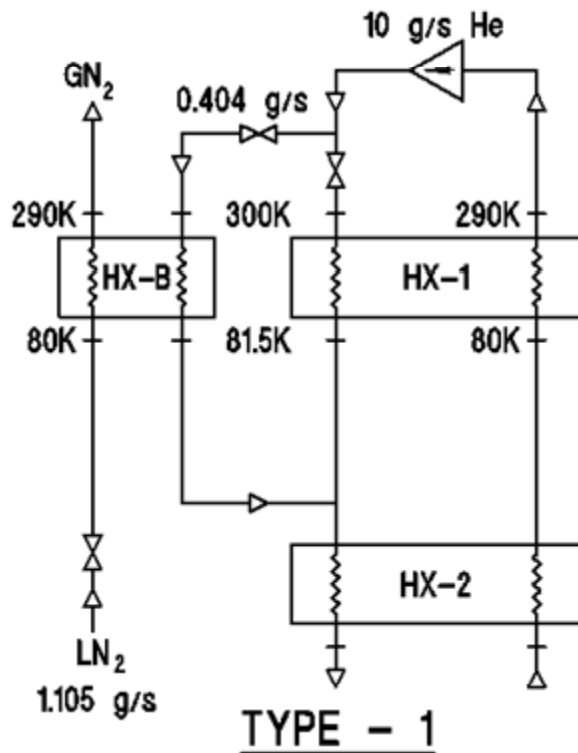

Liquid Nitrogen Pre-cooling (Cont.)

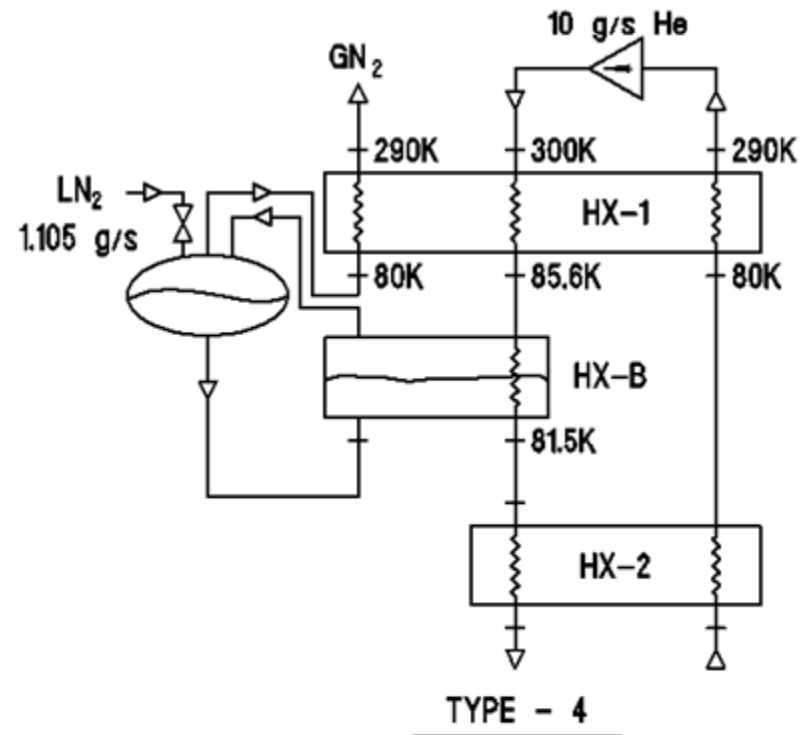
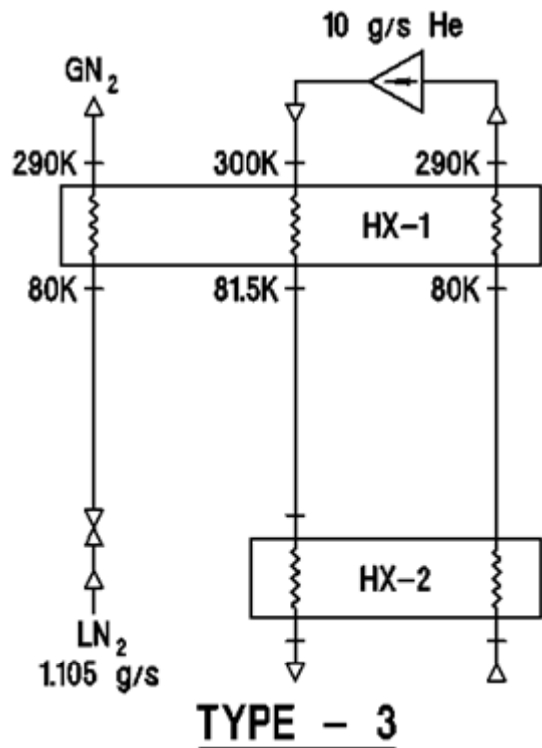

Liquid Nitrogen Pre-cooling (Cont.)

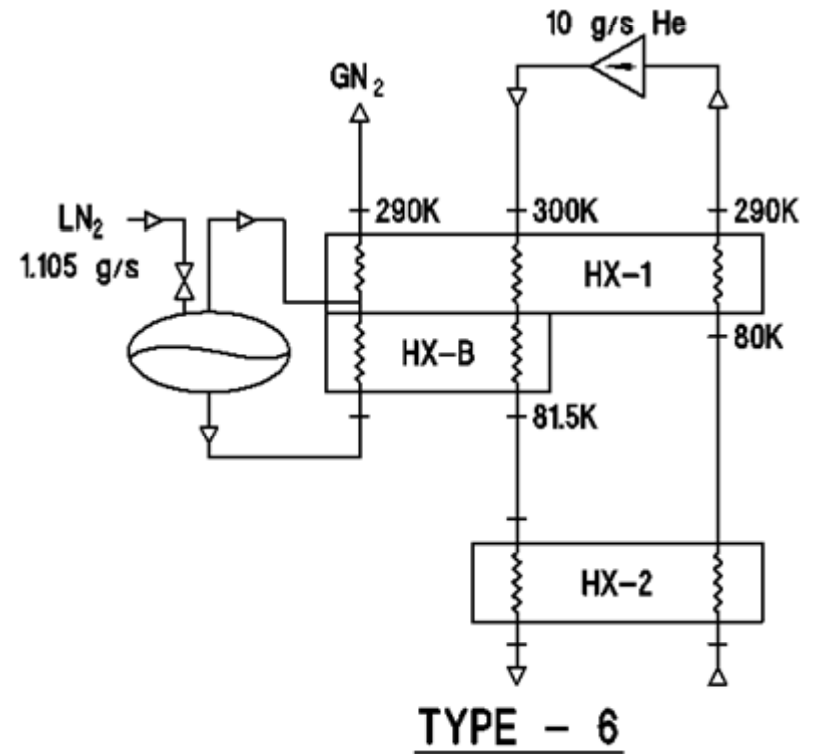
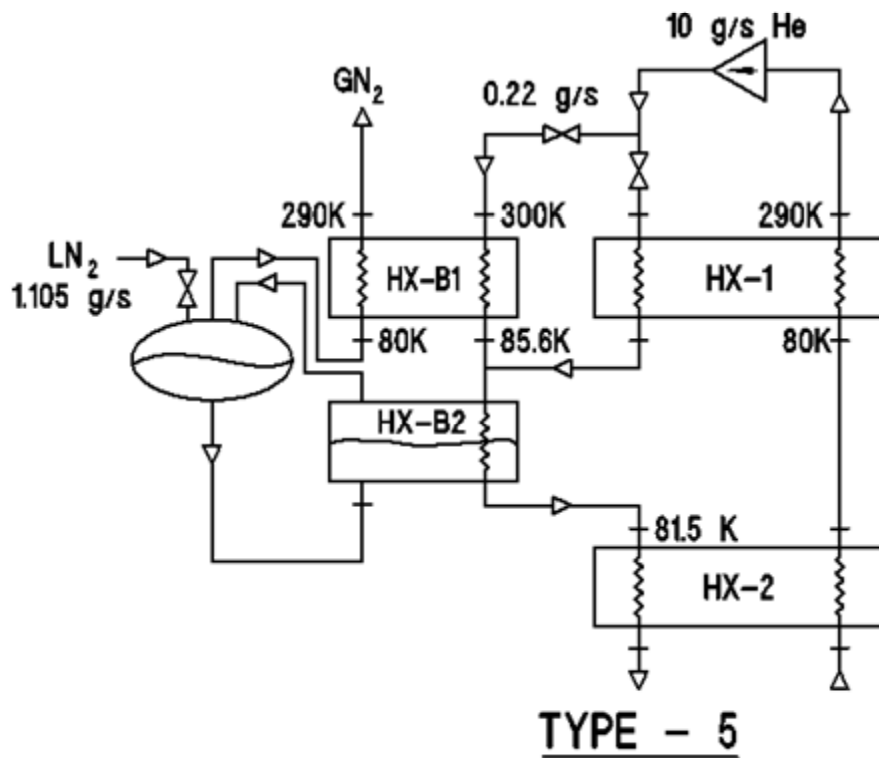

Operated by the Jefferson Science Associates for the U.S. Dept. of Energy



Liquid Nitrogen Pre-cooling (Cont.)

- Types 1, 2 and 5 are common in small helium systems and those limited to two-stream HX's
- Types 3 through 6 are used in medium-to-large helium systems and are normally constructed of brazed aluminum multi-pass HX's
- 80-K level stream temperature difference ($\Delta T_{hl,80K}$) of the typical helium system is in the range of:
 - ▶ 0.5 to 1.5K for the liquefaction mode and,
 - ▶ 1.0 to 2.0K for the refrigeration mode

Note: $\Delta T_{hl,80K}$ is set by the lower HX (shown as HX-2) and not by the pre-cooler!



Liquid Nitrogen Pre-cooling (Cont.)

- For each of these types, to examine the HX requirements for the same LN₂ consumption, the following for each type is applied (which would be typical for a refrigeration mode):
 - Total helium flow (10 g/s)
 - Warm-end stream temperature difference ($\Delta T_{hl,300K} = 10K$) for both helium-helium and helium-nitrogen passes
 - Cold-end stream temperature difference ($\Delta T_{hl,80K} = 1.5K$)

Note: the helium bypass (or slip) flow used to balance the LN₂ refrigeration capacity is essentially the same as the lost refrigeration due to HX-1 finite temperature difference (and, in general, variable specific heat and heat in-leak)



Liquid Nitrogen Pre-cooling (Cont.)

Comparison of HX Types:

Type	HX #	Duty [W]	ΔT_{LM} [K]	C_{min} [W/K]	C_{max} [W/K]	C_R [none]	(UA) [W/K]	NTU [none]	ϵ [%]
Type-1	HX-1	10888	4.48	49.83	51.85	0.961	2430	48.8	99.3
	HX-B	458	4.48	2.10	2.18	0.961	102	48.8	99.3
Type-2	HX-1	10888	4.48	49.83	51.85	0.961	2430	48.8	99.3
	HX-B1	243	40.14	1.16	2.10	0.552	6	5.2	95.5
	HX-B2	215	24.18	2.10	∞	0.000	9	4.2	98.6
Type-3	HX-1	11347	4.48	51.93	54.03	0.961	2532	48.8	99.3
Type-4	HX-1	11134	7.59	51.93	53.02	0.979	1467	28.3	97.5
	HX-B	213	3.11	51.93	∞	0.000	68	1.3	73.2
Type-5	HX-1	10889	7.59	50.79	51.85	0.979	1435	28.3	97.5
	HX-B1	245	7.59	1.14	1.17	0.979	32	28.3	97.5
	HX-B2	213	3.11	51.93	∞	0.000	68	1.3	73.2
Type-6 (Same as Type-4)	HX-1	11134	7.59	51.93	53.02	0.979	1467	28.3	97.5
	HX-B	213	3.11	51.93	∞	0.000	68	1.3	73.2



Liquid Nitrogen Pre-cooling (Cont.)

- Types 1-3 require a high effective HX-1 as compared to the others; i.e., 99.3% as compared to 97.5%
- Types 1-3 require ~60% more total (UA) than does Type 5 for the same LN₂ consumption

Note: HX-1 is by far the largest HX and as such the major cost.

- It is instructive to analyze the following two cases for a Type 1-3 vs. Type 5 pre-cooler as function of a specified (i.e., design) liquefaction load
 - a) LN₂ consumption for the same total (UA)
 - b) Total (UA) required for the same LN₂ consumption



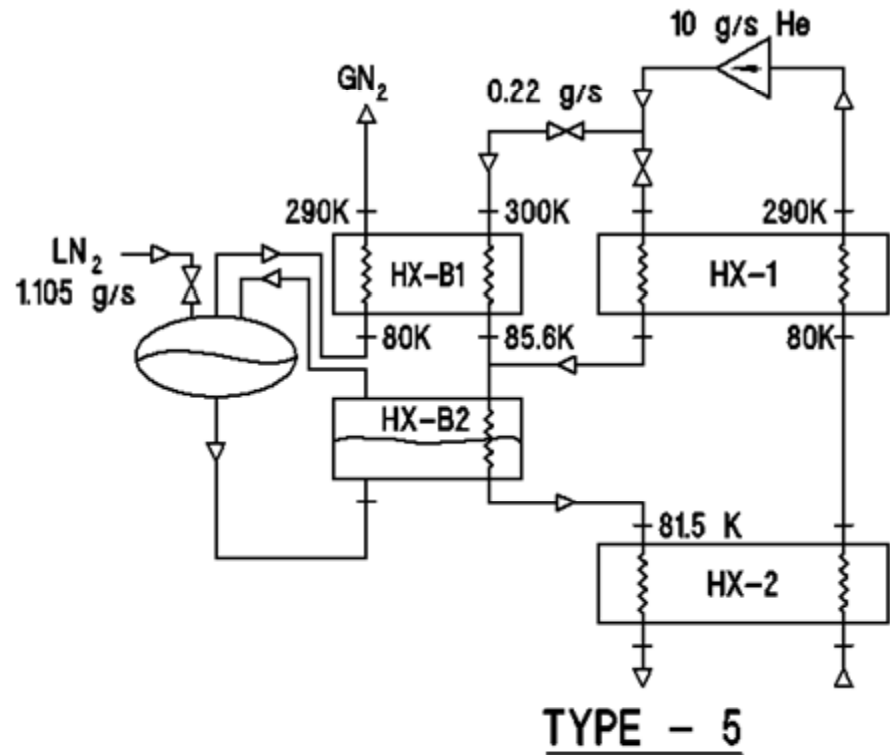
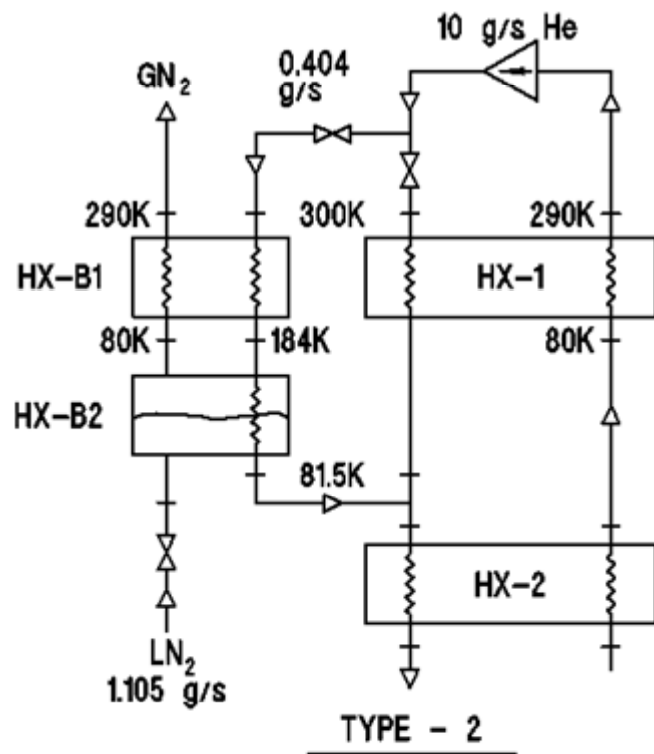

Operated by the Jefferson Science Associates for the U.S. Dept. of Energy

Jefferson Lab
 Thomas Jefferson National Accelerator Facility



Office of Science
 U.S. Department of Energy

Liquid Nitrogen Pre-cooling (Cont.)

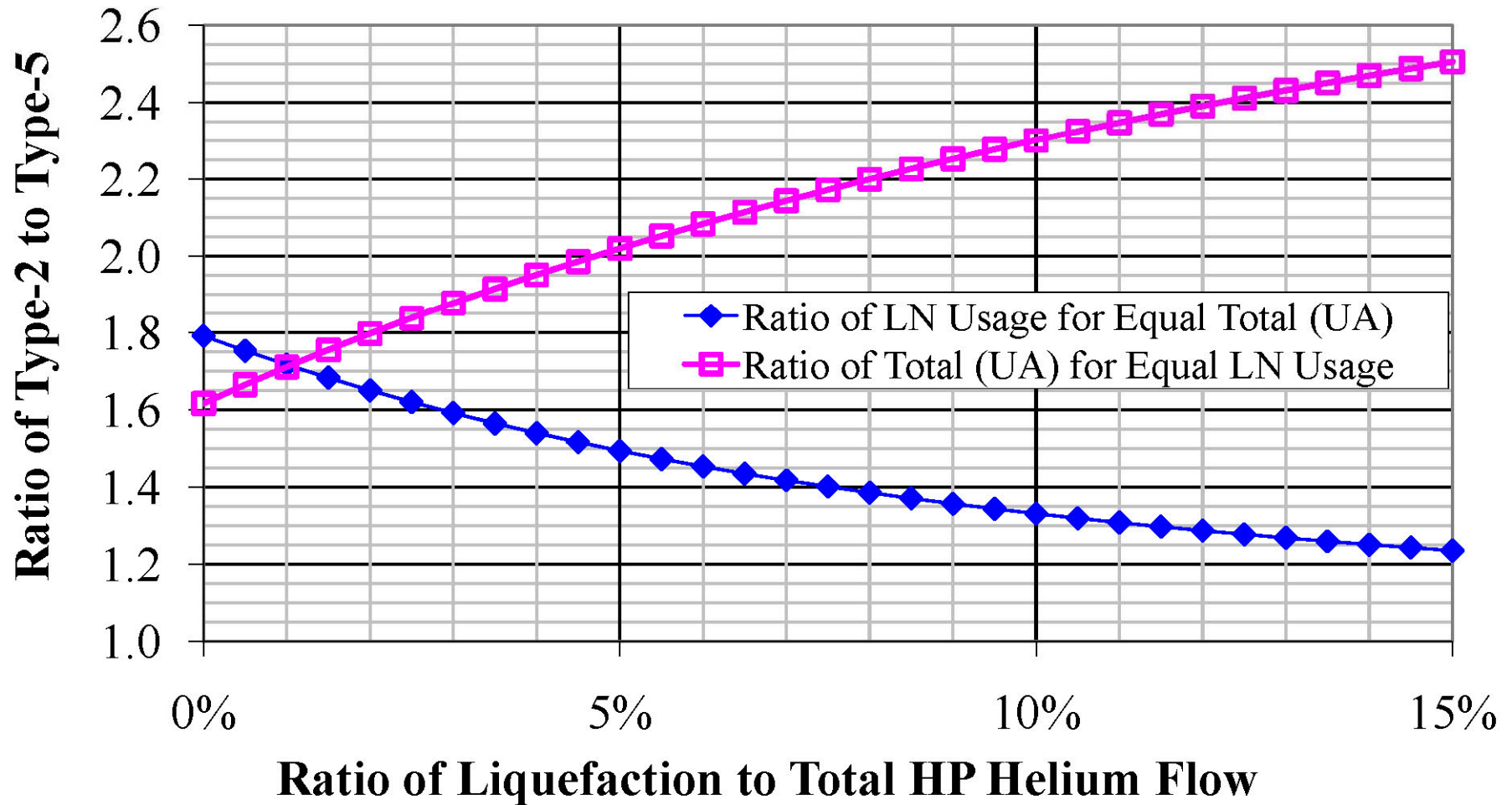

Operated by the Jefferson Science Associates for the U.S. Dept. of Energy



Liquid Nitrogen Pre-cooling (Cont.)

- Type 2, 4 and 5 employ phase-separation; where as in the others the physical location of the phase boundary varies as the system flow and cold-end stream temperature difference ($\Delta T_{hl,80K}$) change
- **Type 6 is not equivalent to Type 4 (or Type 5)!**
 - *There is no phase-separation* – two-phase will enter the (presumed) sensible section
- For Types 1-3, the helium-nitrogen stream temperature difference at the phase boundary is around 100K
Note: this is due to nitrogen's latent heat (~200 J/g) being approximately the same as the sensible heat {i.e., (1.06 J/g-K) (290 – 80 K)=223 J/g}



Liquid Nitrogen Pre-cooling (Cont.)

- The cooling curve for the sensible and latent sections for Types 1-3 is very poor!

Note: this will have a very detrimental effect on the temperature distribution in the helium-helium layers, even if there is proper adiabatic layering!

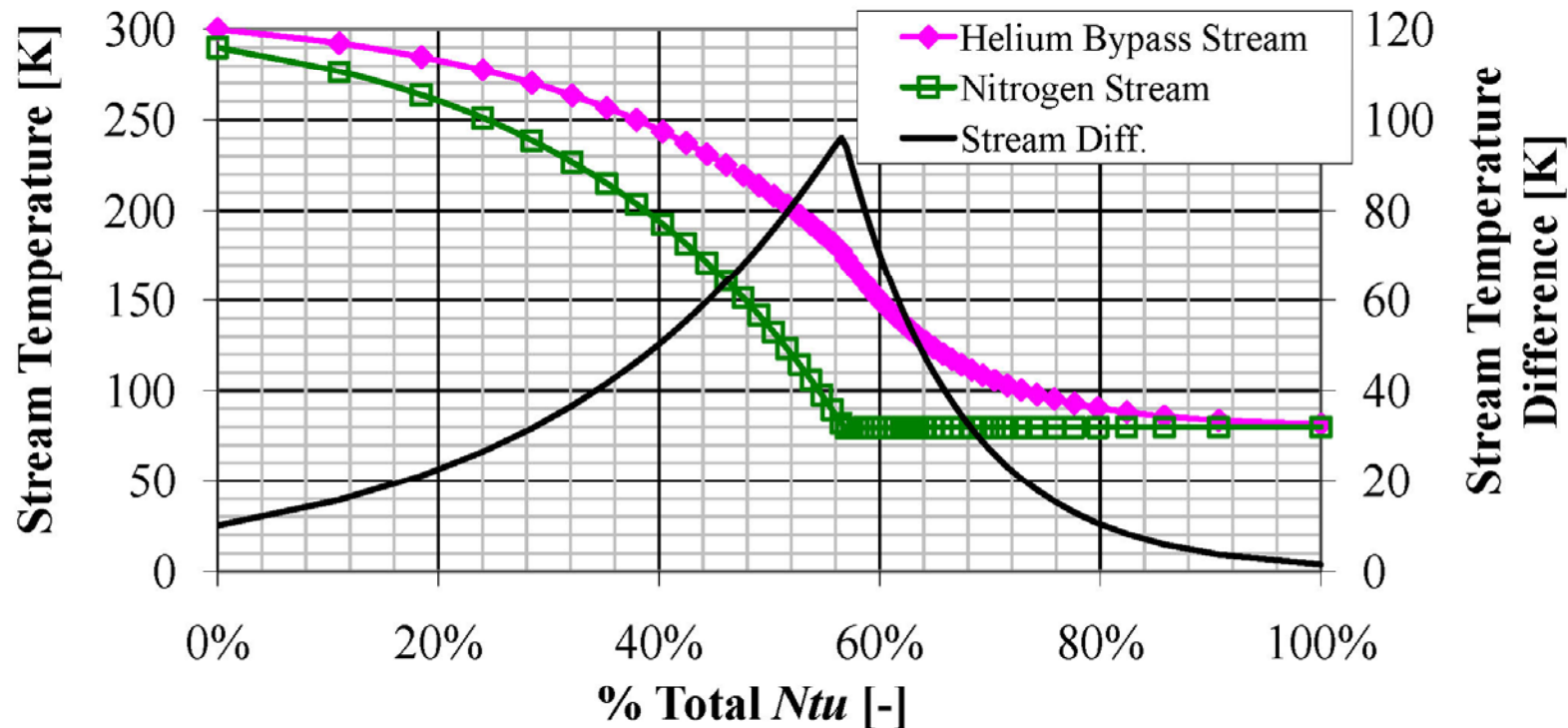

Liquid Nitrogen Pre-cooling (Cont.)

Freezing Danger in Type-3 Arrangement

- Some systems using brazed aluminum HX's and the Type 3 arrangement for LN₂ pre-cooling have experienced HX-1 mechanical failures
- The failure analysis concluded that during an upset load condition when large quantities of low temperature helium were returned, the LN₂ in the brazed aluminum HX-1 passes could be frozen
- As the HX warmed-up during the recovery from the upset condition, some of the HX-1 passes in the middle section warmed and vaporized before the ends has thawed
- May have been a result of flow mal-distribution among the passages and resulted in a large pressure build-up in those passes, resulting in the failure of HX-1
- Types 4 and 5 are now more commonly viewed as solutions to address this potential problem.
- However, unless either an open boiler is used or the thermo-siphon boiler section is properly designed they can have the same danger of LN₂ freezing as Types 1 and 3



Liquid Nitrogen Pre-cooling (Cont.)

Freezing Danger in Type-3 Arrangement

- Properly size the boiler section of the phase separator in Types 4 and 5, so that only nitrogen vapor (i.e., no liquid nitrogen) enters HX-1 and HX-B1
- Even if large quantities of cold helium result from a load upset condition, the large temperature difference required to liquefy the nitrogen vapor (with a latent heat of ~ 200 J/g) and the resulting volume reduction from vapor to liquid ($\sim 200:1$) greatly reduces nitrogen freezing danger of the Type 4 and 5 arrangements
- The refrigeration required to condense and fill the HX passes with LN_2 is more than two orders of magnitude than that required for freezing (i.e., heat of fusion is ~ 240 J/g). Nitrogen frost formed during condensation will result in a reduced heat transfer coefficient which will further reduce the potential to liquefy and freeze the nitrogen in this arrangement
- These are the probable reasons the Type 4 and 5 arrangements have not experienced the Type 3 arrangement failure



Liquid Nitrogen Pre-cooling (Cont.)

More on the Type 6 arrangement

- It appears to accomplish the same as Type 5 but with fewer number of piping connections
- Recall that for a thermo-siphon the circulated LN₂ flow is much higher (by 8 to 20 times) than the LN₂ consumed
- As such, the heat transfer surface is fully wetted and the evaporative heat transfer coefficient (i.e., the “U”) is two orders of magnitude higher as compared to the partially vapor blanketed surface in a Type 6 arrangement
- So then, for a Type 6 arrangement requires much more heat transfer surface area to achieve the same overall (UA) than as compared to Types 4 and 5



Liquid Nitrogen Pre-cooling (Cont.)

More on the Type 6 arrangement (continued)

- There is really no phase-separation for a Type 6 arrangement
- This arrangement can have significant liquid carry-over to the (supposed) sensible section, and
- This arrangement is vulnerable to LN₂ freezing as is the Type 3 arrangement
- Additionally, temperature variations due to the liquid carry-over result in temperature transients on the entire system operation

The user should beware that in practice this system will very likely be quite difficult to control in a stable manner and not achieve the design LN₂ consumption!



Liquid Nitrogen Pre-cooling (Cont.)

The Type 5 arrangement offers a distinct advantage over Type 4 that is not necessarily apparent at first glance

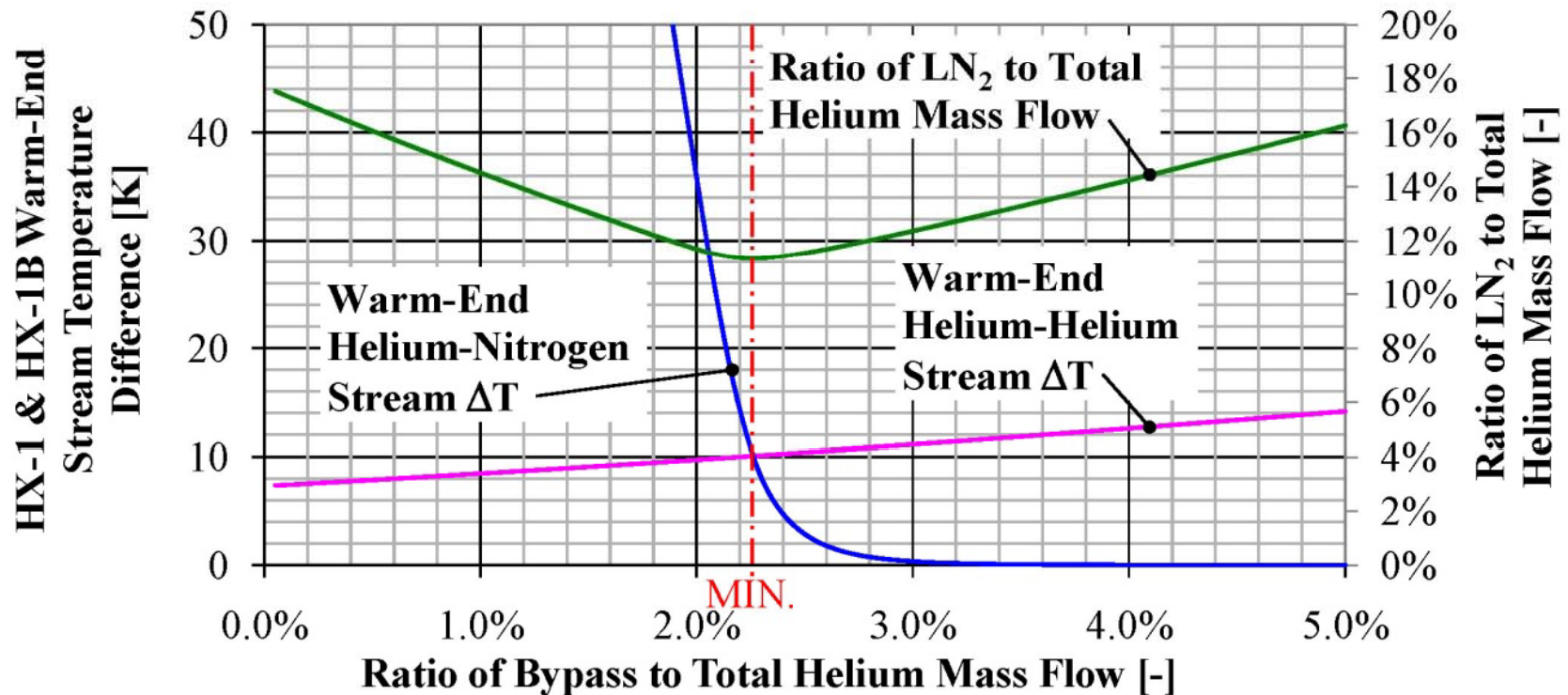

Although for a particular case, the above depicts the behavior of a Type 5 arrangement as the high pressure bypass valve position is varied (affecting the helium mass flow through HX-1 and HX-1N)



Operated by the Jefferson Science Associates for the U.S. Dept. of Energy



Liquid Nitrogen Pre-cooling (Cont.)

Three features are apparent:

1. There is a unique position of the bypass valve that will result in a minimum LN₂ consumption for a given set of process conditions.
2. Using the warm-end helium-nitrogen stream temperature difference as a process variable is either unstable or ineffective for achieving the minimum LN₂ consumption.
3. Although the warm-end helium-helium stream temperature difference does not exhibit a stationary value, excluding conditions that result in a very cold nitrogen vent temperature (i.e., large warm-end helium-nitrogen stream temperature difference), it tracks with the LN₂ consumption over a wide operating range.

Type 4 and 6 offer no means to affect minimum LN₂ consumption; i.e., it will be solely determined by the actual hardware performance and load conditions



Operated by the Jefferson Science Associates for the U.S. Dept. of Energy



Liquid Nitrogen Pre-cooling (Cont.)

HX-1 vs. LN₂ Consumption

LN₂ consumption is insensitive to extreme warm-end helium-nitrogen stream temperature differences

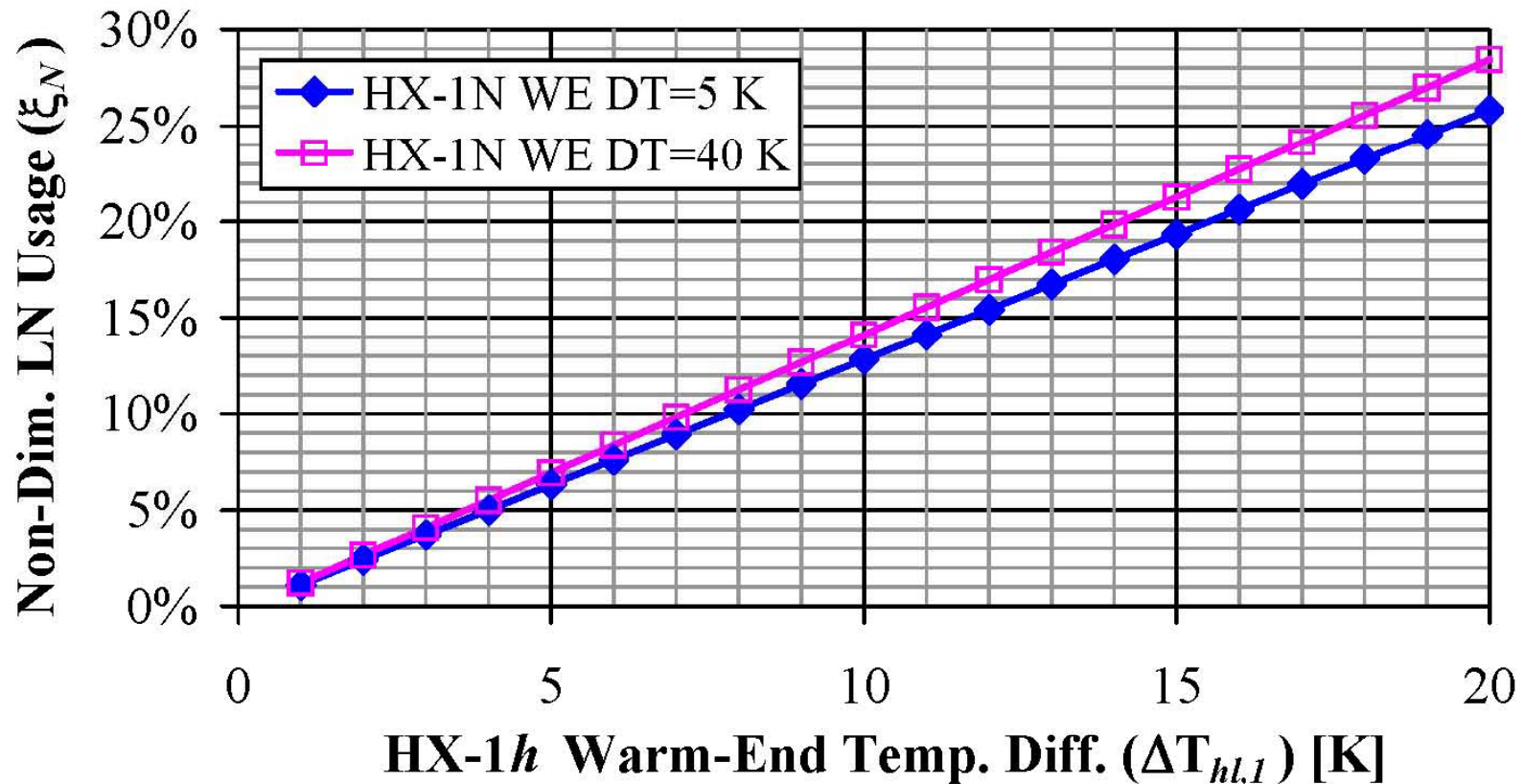

Operated by the Jefferson Science Associates for the U.S. Dept. of Energy



Liquid Nitrogen Pre-cooling (Cont.)

HX-1 vs. LN₂ Consumption

LN₂ consumption is insensitive to the size of the sensible section of the helium-nitrogen HX

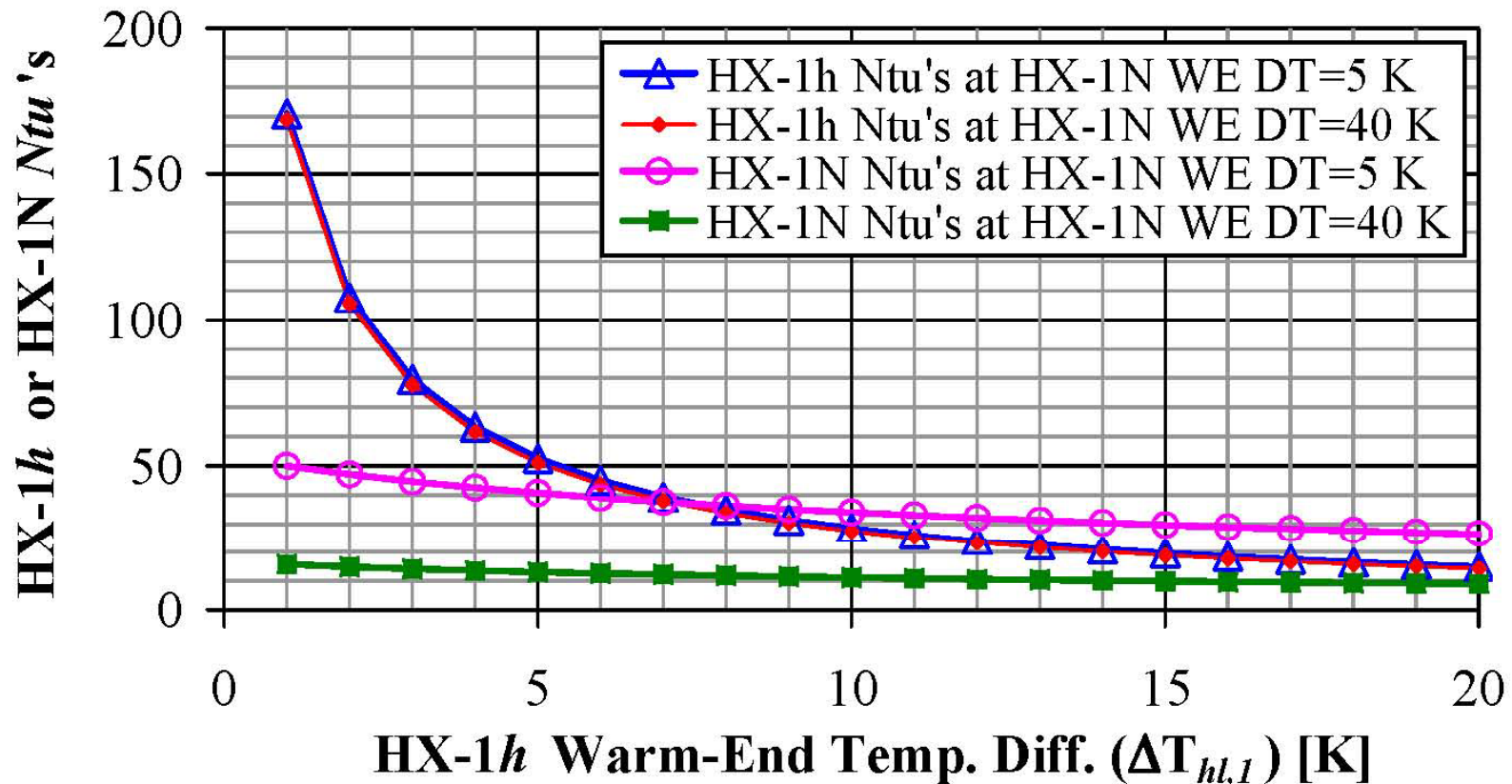

Liquid Nitrogen Pre-cooling (Cont.)

Two key parameters are evident!

- For pre-cooler design, it is the size (total heat transfer area and length) and design (i.e., proper layering, core to distributor pressure ratio, core+distributor to header+nozzle pressure ratio, etc.) of the (300-80K) helium-helium HX that dominates the (design) LN₂ consumption
- For operation of a pre-cooler, it is the warm-end helium-helium stream temperature difference that is the proper process variable to affect minimum LN₂ consumption stably



Liquid Nitrogen Pre-cooling (Cont.)

- The following summarizes the preferable control philosophy to affect minimum LN₂ consumption and a stable system for each pre-cooler type

	Control Element	Process Variable	Action (Gain)
Types 1 & 3	Position of LN ₂ Supply Valve	Warm-End (300K) Helium-Helium Stream Temperature Difference	Direct
Types 1 & 3	Max. Position of LN ₂ Supply Valve	Warm-End (300K) Helium-Nitrogen Stream Temperature Difference	Direct
Types 4 & 5	Position of LN ₂ Supply Valve	Phase-Separator Liquid Level	Direct
Types 2 & 5	Position of High Pressure Helium Bypass Valve	Warm-End (300K) Helium-Helium Stream Temperature Difference	Direct
Types 2 & 5	Min. Position of High Pressure Helium Bypass Valve	Warm-End (300K) Helium-Nitrogen Stream Temperature Difference	Reverse



Liquid Nitrogen Pre-cooling (Cont.)

Alternate LN₂ Pre Cooling Arrangements (Type 7)

- Multi-stream heat exchanger (HX) designs used for LN₂ pre-cooling have contributed to additional LN₂ consumption as compared to their design goals
- Other than being under-sized, there are two main reasons for this problem:
 - Flow distribution in the different pressure (stream) passes
 - Improper design
 - Manufacturing
 - Mode changes (refrigeration vs. liquefaction)
 - Layering sequence of the stream passes
- Alternate designs, or their logical extensions, allow for flow balancing, so that problems associated with flow distribution can be addressed



Liquid Nitrogen Pre-cooling (Cont.)

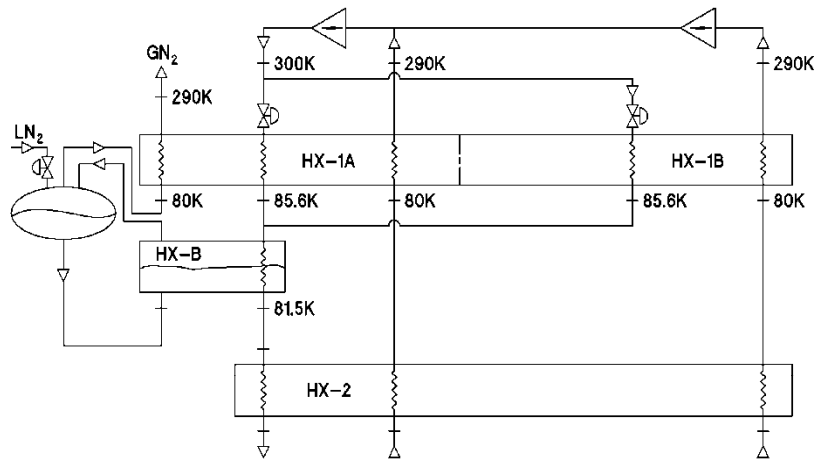

Type 7(a)

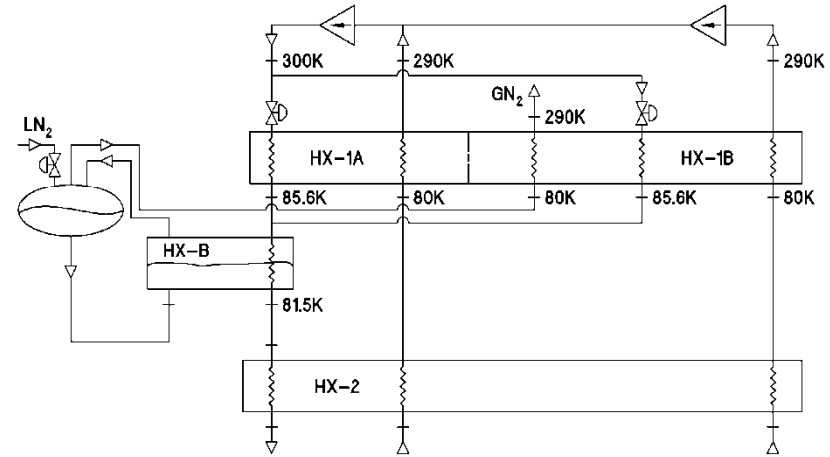

Type 7(b)

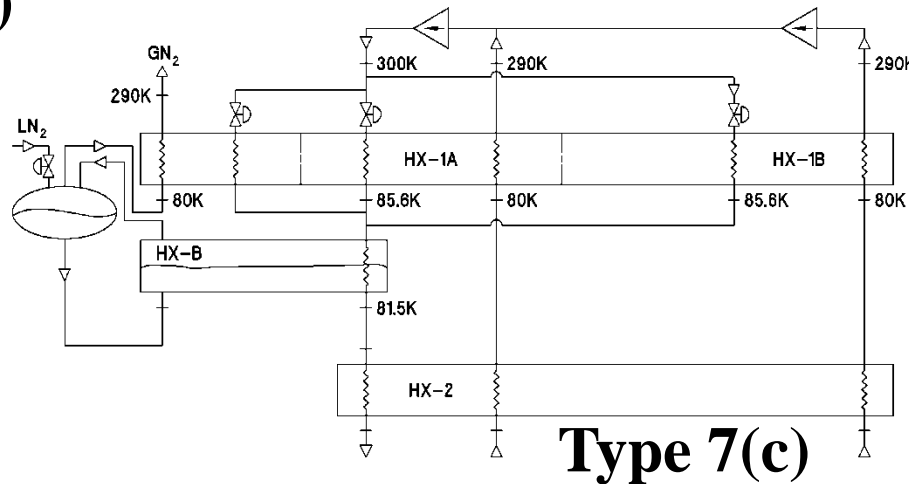

Type 7(c)



Liquid Nitrogen Pre-cooling (Cont.)

Simplified Operating Cost Comparison

- To compare LN₂ pre-cooling to turbine cooling based upon an equal operating cost basis, refer to the three methods depicted in the figures Type-A, Type-B and Type-C.
- Each accomplishes the cooling of 1 g/s of helium from 300-80K.
- The 1 g/s represents the additional total cooling flow load for a combination of liquefaction load and HX losses (due to finite stream temperature differences and heat leaks)



Liquid Nitrogen Pre-cooling (Cont.)

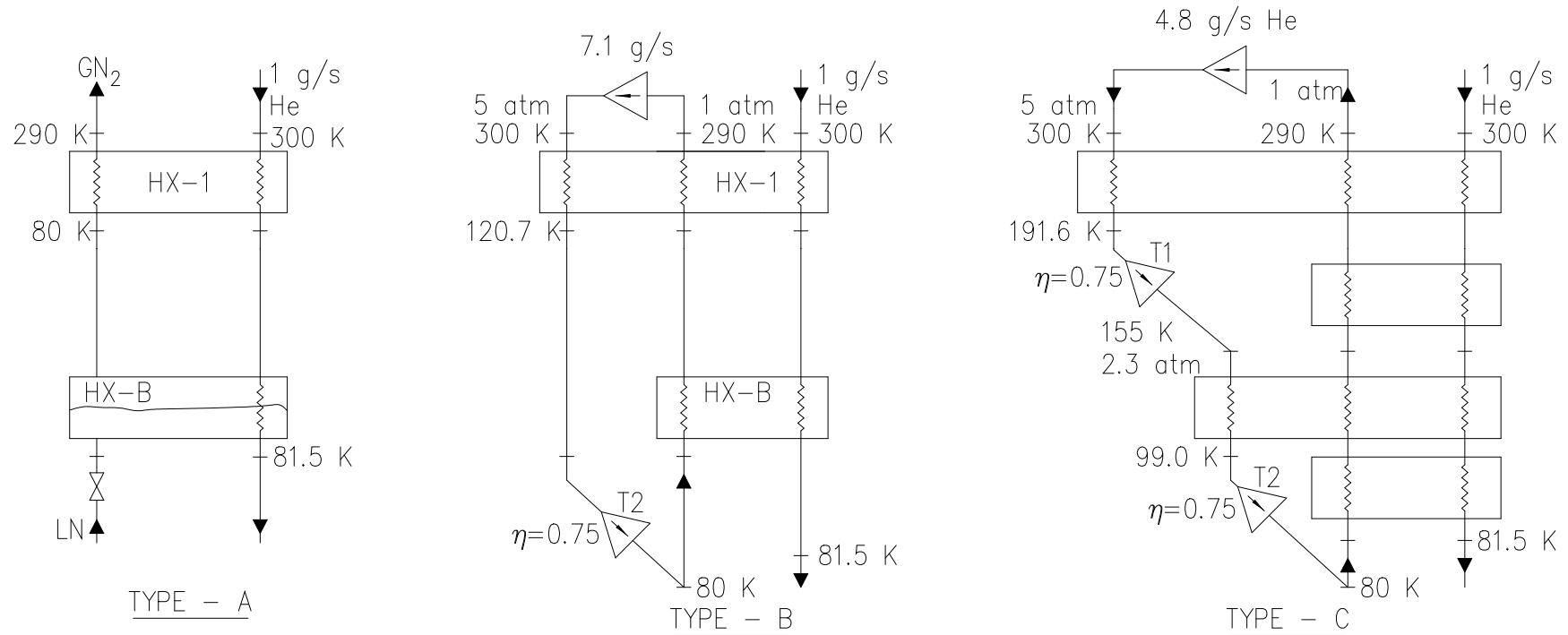

Operated by the Jefferson Science Associates for the U.S. Dept. of Energy



Liquid Nitrogen Pre-cooling (Cont.)

	LN ₂ Cost Break-Even Point Analysis			
	Units	TYPE-A	TYPE-B	TYPE-C
Helium Liquefaction Flow	g/s	1.0	1.0	1.0
LN ₂ Flow	g/s	2.7	—	—
	l/hr	12	—	—
Expander Efficiency(s)		—	0.7	0.7
Compressor Recycle Flow	g/s	—	6.5	4.5
Comp. Isothermal Eff.		—	0.5	0.5
Comp Power Input	kW	—	13	9
<i>Given:</i>				
LN ₂ Cost	\$/liter	0.06	—	—
Electric Power	\$/kW-h	0.04	—	—
LCF		—	1.38	2.00



Liquid Nitrogen Pre-cooling (Cont.)

Simplified Operating Cost Comparison

- Based on the above example analysis of operating cost for assumed LN₂ and electric power costs, LN₂ cooling is 1.16 times more expensive compared to the single expander system and 1.72 times more expensive for the two expander system.
- So, for a system that uses 1000 liters/hr (i.e., 264 gal/hr or 225 g/s or \$482,000/yr) of LN₂ over one year period, a savings of \$66,000 would be made using Type-B and \$200,000 for a Type-C turbine pre-cooling system rather than LN₂.



Liquid Nitrogen Pre-cooling (Cont.)

Simplified Operating Cost Comparison – Conclusions

- **Such an analysis should not be used to exclude a dual option system using both turbine and LN₂ pre-cooling**
- **Circumstances and operational requirements that make such a dual option prudent**
- **it may be cost effective to use a dual system to take advantage of the changes in electric power and LN₂ pricing, or to meet system availability requirements.**
- **Or, in cases where a normal and back-up system are required to meet a specified system availability (e.g., considering weather constraints on LN₂ deliveries or power constraints on turbine cooling) or for maintenance modes, a dual system could be beneficial.**



7. Helium Refrigeration Systems for Below 4.2 K Operations

Used for refrigeration at temperatures below the atmospheric pressure saturation temperature (4.22K)

These systems inherently appear as liquefaction loads to the main (4K) refrigeration system, which is *providing the refrigeration*

The nominal 2K systems (below 2.17K lambda point) have become the norm for especially the superconducting radio frequency (SRF) technologies or the multi SRF niobium cavity cryomodules

The performance comparisons are made for 2K operation for illustration purposes



Helium Refrigeration Systems for Below 4.2 K Operations (Cont.)

The following four refrigeration process types describe some of the system design options available for sub-atmospheric load operation.

Type-1: Vacuum pumping on a helium bath

Type-2: Sub-atmospheric refrigeration system

Type-3: Cold compressor System

Type-4: Hybrid systems



Operated by the Jefferson Science Associates for the U.S. Dept. of Energy



Helium Refrigeration Systems for Below 4.2 K Operations (Cont.)

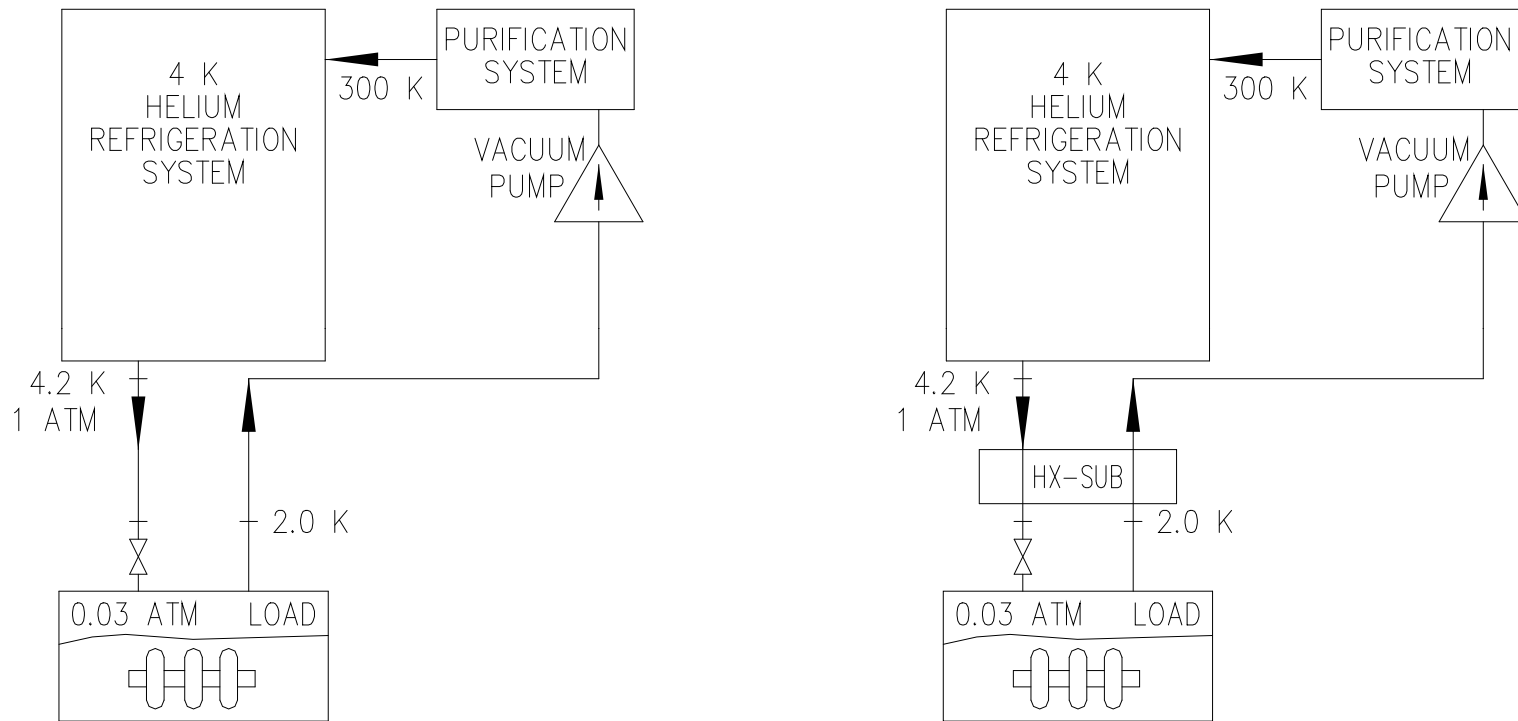

Figure 7.1.1: Vacuum pumping on the helium bath



Helium Refrigeration Systems for Below 4.2 K Operations (Cont.)

1 g/s of 1 atm. saturated liquid helium will provide ~ 15 j/g or 15W of refrigeration capacity at 2.0K.

The Carnot work required is that for 1 g/s of 4.2K liquefaction Carnot work (~100 W of 4.2K refrigeration Carnot work) plus the vacuum pump isothermal compression work.

The Carnot specific power for this (Type-1-a) process is

$$\begin{aligned} &= [(T_0 \cdot \Delta S - \Delta H) + RT_i \ln(Pr)] \\ &= [(6840) + (2.077 \cdot 300 \cdot \ln \{1/0.03\})] \text{ w/(g/s)} / 15 \text{ w/(g/s)} \\ &= [6840 + 2185] / 15 = \sim 600 \text{ w/w} \end{aligned}$$



Helium Refrigeration Systems for Below 4.2 K Operations (Cont.)

In an improved system including the sub-cooling heat exchanger (HX-Sub) shown in Figure 7.1.1 (b), 1 g/s of 1 atm. saturated liquid helium will provide ~ 20 j/g or 20W of refrigeration capacity at 2.0K.

The Carnot specific power for this (Type-1-b) process is

$$\begin{aligned} &= [(T_0 \cdot \Delta S - \Delta H) + RT_i \ln(Pr)] \\ &= \left[(6840) + (2.077 \cdot 300 \cdot \ln \{1/0.03\}) \right] \text{ w/(g/s)} / 20 \text{ w/(g/s)} \\ &= [6840 + 2185] / 20 = \sim 450 \text{ w/w} \end{aligned}$$

Or, the option (b) is ~25% more efficient than option (a)



Operated by the Jefferson Science Associates for the U.S. Dept. of Energy



Helium Refrigeration Systems for Below 4.2 K Operations (Cont.)

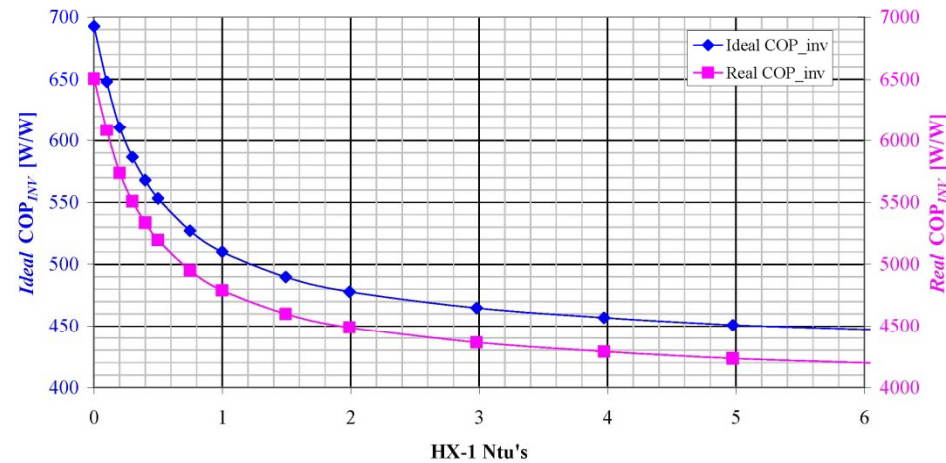

Advantages:

- Simple system
- Smallest capital cost

Disadvantages:

- High operating cost



Operated by the Jefferson Science Associates for the U.S. Dept. of Energy



Helium Refrigeration Systems for Below 4.2 K Operations (Cont.)

Type-2: Sub-atmospheric refrigeration system

This is an extension of the usual 4K helium refrigeration system design with the low pressure stream operating at sub-atmospheric conditions.

In this design type the practical constraints, such as the low-pressure stream pressure drop ($\Delta p/p_\infty$ to the exergy loss) need to be addressed very carefully.

Type-2 process can be approximated with a standard 4K system by adding sub-atmospheric components as shown in Figure 7.2.2. Although the process is not as efficient as the integrated design, it is widely practiced with minor variations due to its ease of addition to an existing 4K system.



Helium Refrigeration Systems for Below 4.2 K Operations (Cont.)

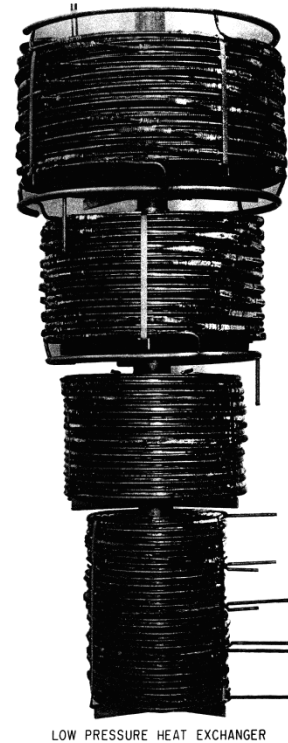

**10 Torr pressure
on the low
pressure side of
the heat
exchangers**

Figure 7.2.1: Stanford University 300W, 1.8 K Helium Liquefier (1969)



Operated by the Jefferson Science Associates for the U.S. Dept. of Energy



Helium Refrigeration Systems for Below 4.2 K Operations (Cont.)

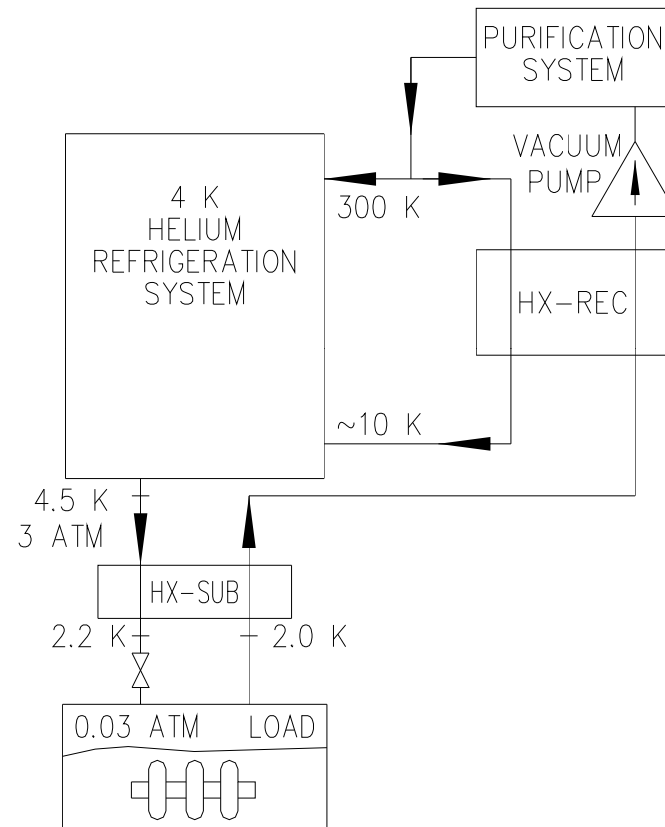

Figure 7.2.2: Vacuum pumping on the helium bath with HX



Helium Refrigeration Systems for Below 4.2 K Operations (Cont.)

In this design with a load heat exchanger (HX-Sub), 1 g/s of helium flow to the load will provide ~20 J/g or 20W of refrigeration capacity at the required operating condition (e.g., 2K)

This in turn requires the input power required for 0.1 g/s liquefaction capacity from 300K to 4.5K and the 0.9 g/s liquefaction capacity from 10K to 4.5K plus the vacuum pump input power

In both Types 1&2 the vacuum pump power required remains the same

It is easier to transition to the load conditions (pump down)



Operated by the Jefferson Science Associates for the U.S. Dept. of Energy



Helium Refrigeration Systems for Below 4.2 K Operations (Cont.)

The Carnot specific power for this (Type-2) process is

$$\begin{aligned} &= \left[(0.1*6830) + (0.9*3003) + (2.077*300*\ln \{1/0.03\}) \right] \text{ w/(g/s)} / 20 \text{ w/(g/s)} \\ &= [683 + 2703 + 2185] / 20 = \sim 280 \text{ w/w} \end{aligned}$$

pressure drop (assumed to be 0.005 atm) and its sensitivity is as given in Type-2c calculation. The Carnot specific power for Type-2c is

$$\begin{aligned} &= \left[(0.1*6830) + (0.9*3003) + (2.077*300*\ln \{1/0.025\}) \right] \text{ w/(g/s)} / 20 \text{ w/(g/s)} \\ &= [683 + 2703 + 2300] / 20 = \sim 284 \text{ w/w} \end{aligned}$$



Helium Refrigeration Systems for Below 4.2 K Operations (Cont.)

Although the pressure drop effect on Carnot specific power seems rather less significant, in actual systems this has very strong influence on the vacuum pump pumping capacity and its efficiency.

In the extreme limit, the vacuum pump ultimate pressure may limit the final temperature achievable for a given load.

APPENDIX – D



Operated by the Jefferson Science Associates for the U.S. Dept. of Energy



Helium Refrigeration Systems for Below 4.2 K Operations (Cont.)

Advantages:

- Proven components for the system design
- Can be added to an existing 4K system with the addition of a refrigeration recovery heat exchanger
- Easy to reach load operating conditions
- Easy to efficiently turn down the system capacity to meet the reduced load

Disadvantages:

- Any leaks to the sub-atmospheric portion will contaminate the system
- Sub-atmospheric vacuum pumps and compressors are less efficient
- Pressure drop on the low pressure side of the refrigeration recovery HX and the system economics normally limit the system design to small to medium size loads (less than ~1KW at 2K) at low pressure (0.03 atm or 2K) operations



Operated by the Jefferson Science Associates for the U.S. Dept. of Energy



Helium Refrigeration Systems for Below 4.2 K Operations (Cont.)

Type-3: Cold Compressor System

As explained above, Types 1&2 are not economical solutions for large capacity (typically $> 1\text{kW}$) nominal 2K refrigeration systems.

The volume flow and pressure ratios are too large for efficient compression of helium gas at room temperature with currently available sub-atmospheric equipment.

In a Type-3 system utilizing cold compressors (CC's), the process can be designed with minimum (to none) warm end sub-atmospheric components in the system. Since the helium is compressed at the cold end, the energy input to compress the helium including the compression inefficiencies is transferred as a refrigeration load to the 4K cold box and ultimately rejected to the environment through the 4K system compressors.



Helium Refrigeration Systems for Below 4.2 K Operations (Cont.)

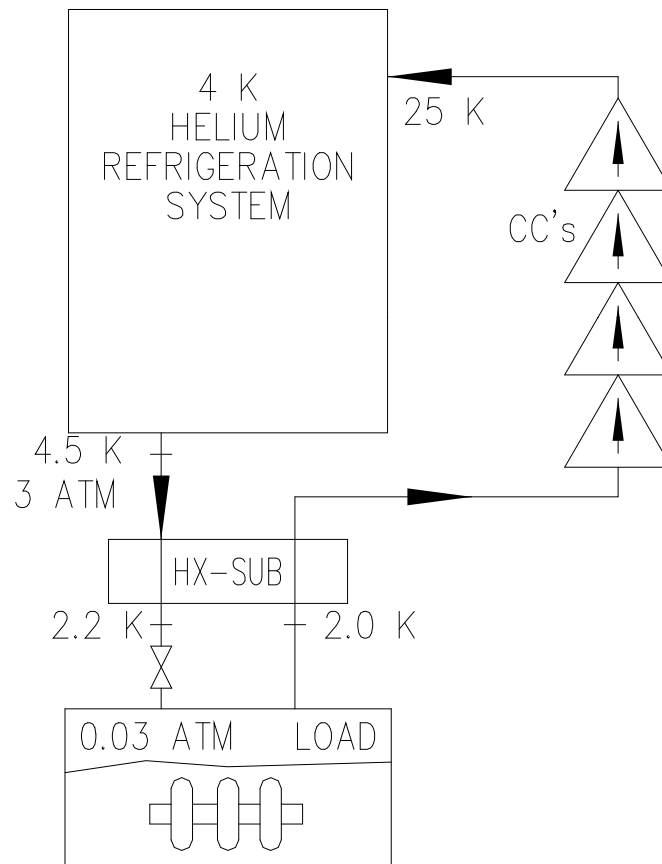

Helium Refrigeration Systems for Below 4.2 K Operations (Cont.)

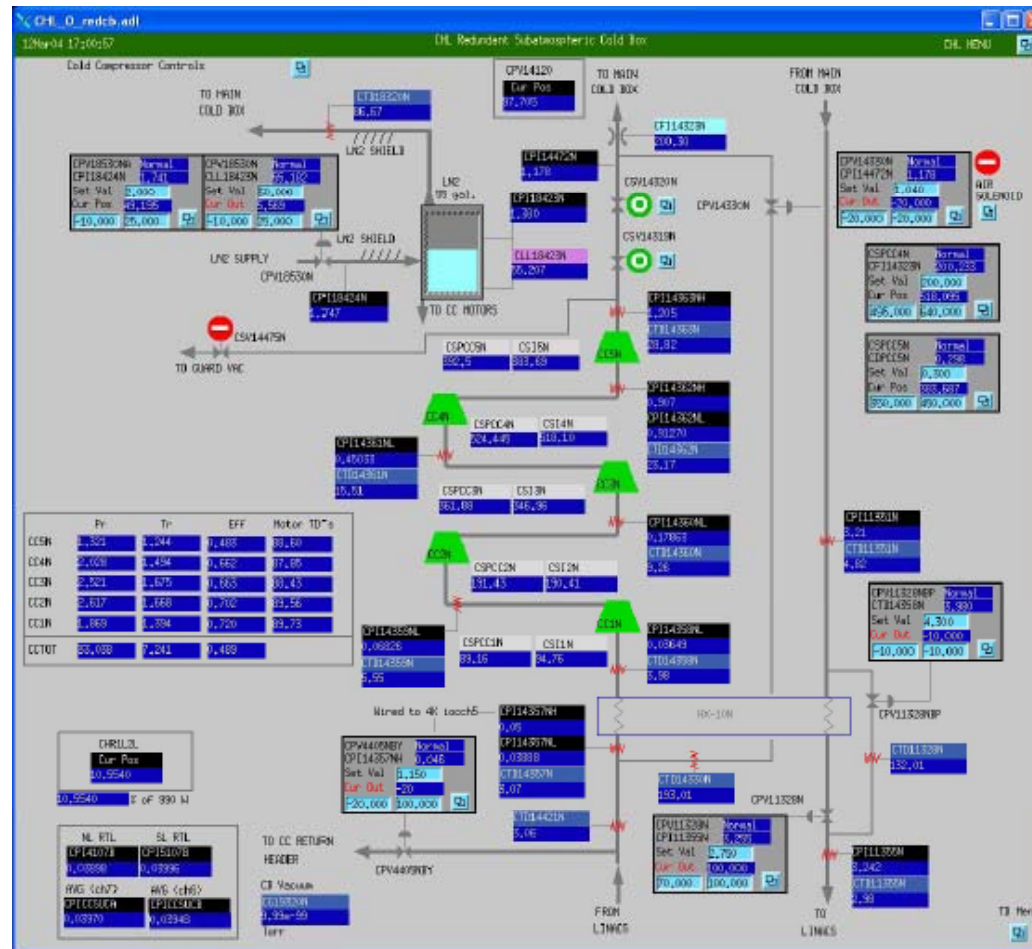

Figure 7.3.1: JLab Cold Compressor System



Operated by the Jefferson Science Associates for the U.S. Dept. of Energy



Helium Refrigeration Systems for Below 4.2 K Operations (Cont.)

Type-3: Cold Compressor System (cont.)

The Type-3 process has many advantages and is used in many large systems. Figure 7.3.1 illustrates the cold compressor system used by JLab and a similar four-stage system designed by JLab presently in use at SNS.

The final HX-SUB should be located close to the load (e.g., SNS system) so that the distribution system heat leak is a 4K (low Carnot value) instead of 2K load, resulting in reduced CC flow and improved process efficiency.

The process of transforming the load condition from positive pressure (e.g., ~ 1atm) to the load operating conditions (e.g., ~0.03 atm) is called “pump down”. The challenge is to find a satisfactory thermodynamic path (pump down path) to the final condition without violating any equipment operational limits or causing an emergency shutdown (a “trip”) of the cold compressor system.



Helium Refrigeration Systems for Below 4.2 K Operations (Cont.)

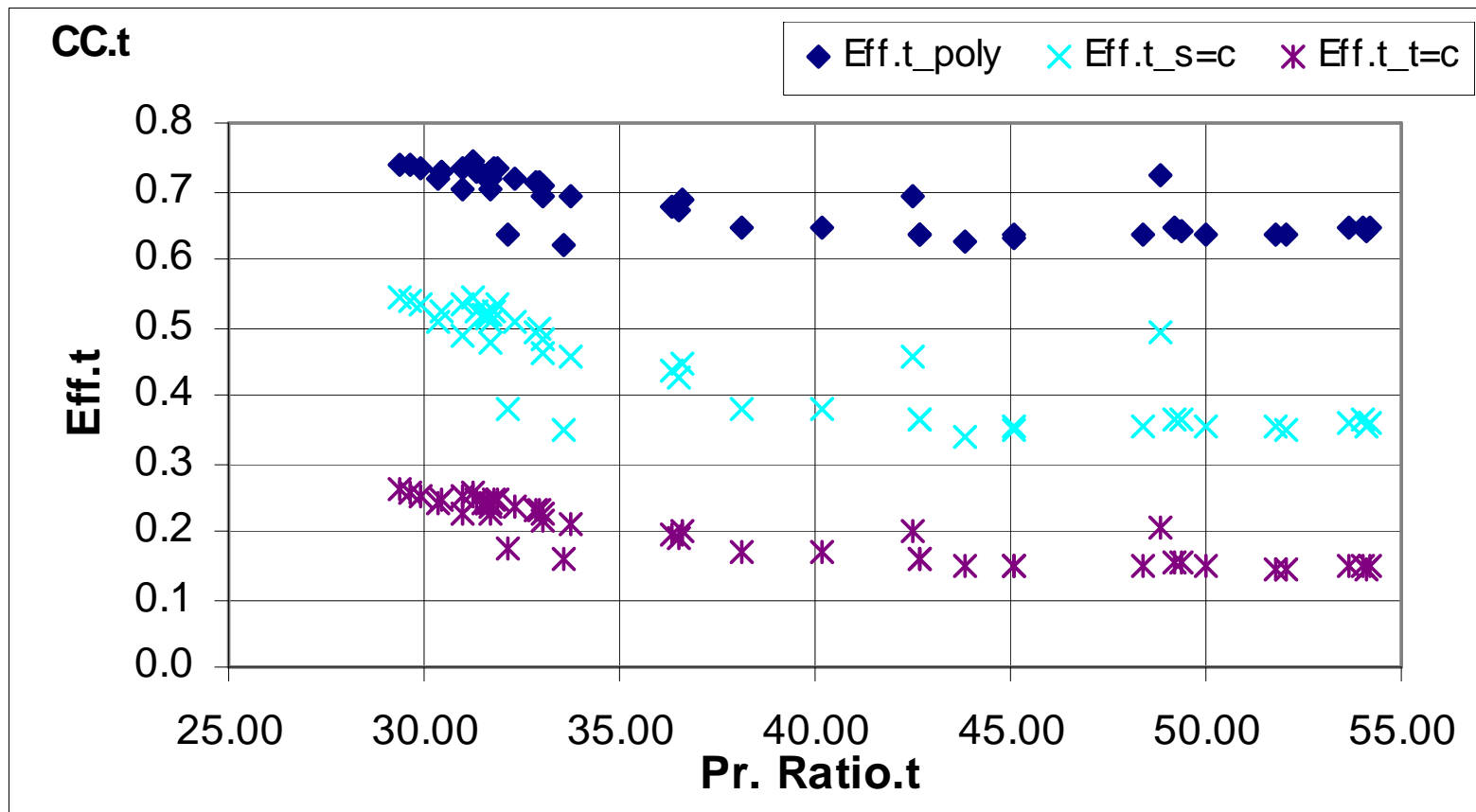

Operated by the Jefferson Science Associates for the U.S. Dept. of Energy



Helium Refrigeration Systems for Below 4.2 K Operations (Cont.)

Type-3: Cold Compressor System (cont.)

During the initial commissioning of the first Jlab 2K system in 1994, the causes for the instabilities (large flow variations) in the system during pump down were not understood.

At that time, the instabilities were believed to be caused by the compressor surge and stall characteristics.

By trial and error a successful and repeatable pump down path was found and JLAB continued to operate on that path.

During the commissioning of the second Jlab 2K system in 1999, it was apparent that the limitation of available torque from the cold compressor motors was one of the main reasons for the instabilities in the system during pump down. It was also identified that the power factor (PF) of the motor was one of the factors limiting the available cold compressor torque during pump down.



Operated by the Jefferson Science Associates for the U.S. Dept. of Energy



Helium Refrigeration Systems for Below 4.2 K Operations (Cont.)

Type-3: Cold Compressor System (cont.)

This was the initial recognition that the flow instabilities were more probably the result of the motor characteristics than the cold compressor wheel characteristics, just the opposite of what was thought in 1994.

Since the motor and the compressor are on the same shaft, it was difficult to separate the cause and effect phenomena.

The recent testing at SNS provided the following additional insight.

The PF for all the cold compressor motors exhibited the following characteristic as shown in Figure 7.3.3 with respect to the speed.

Before this test at SNS in March of 2005, the periodic 60HZ influence on the PF was neither known nor anticipated.



Operated by the Jefferson Science Associates for the U.S. Dept. of Energy



Helium Refrigeration Systems for Below 4.2 K Operations (Cont.)

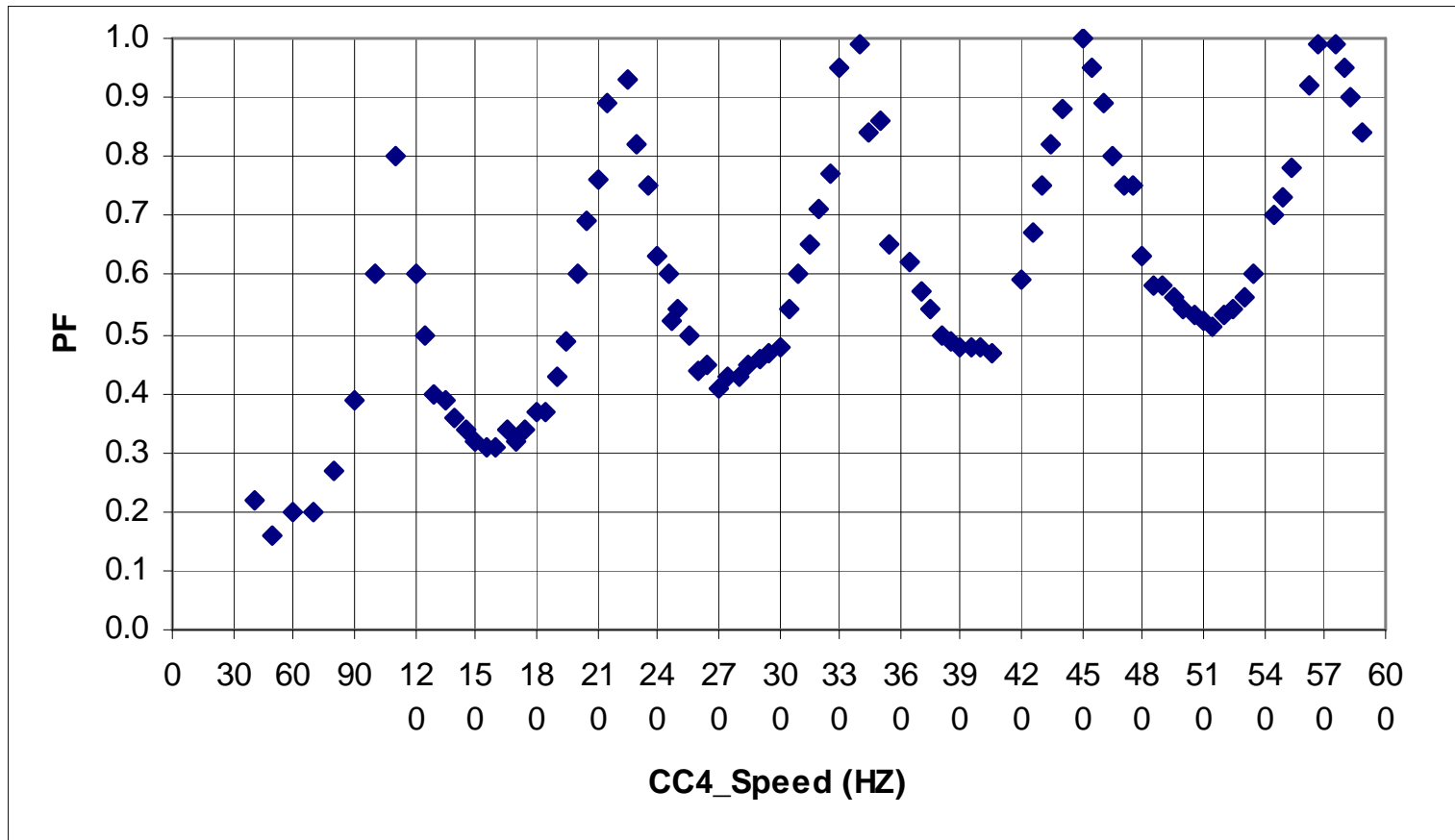

Figure 7.3.3: Variable frequency drive power factor (PF) with respect to speed



Operated by the Jefferson Science Associates for the U.S. Dept. of Energy



Helium Refrigeration Systems for Below 4.2 K Operations (Cont.)

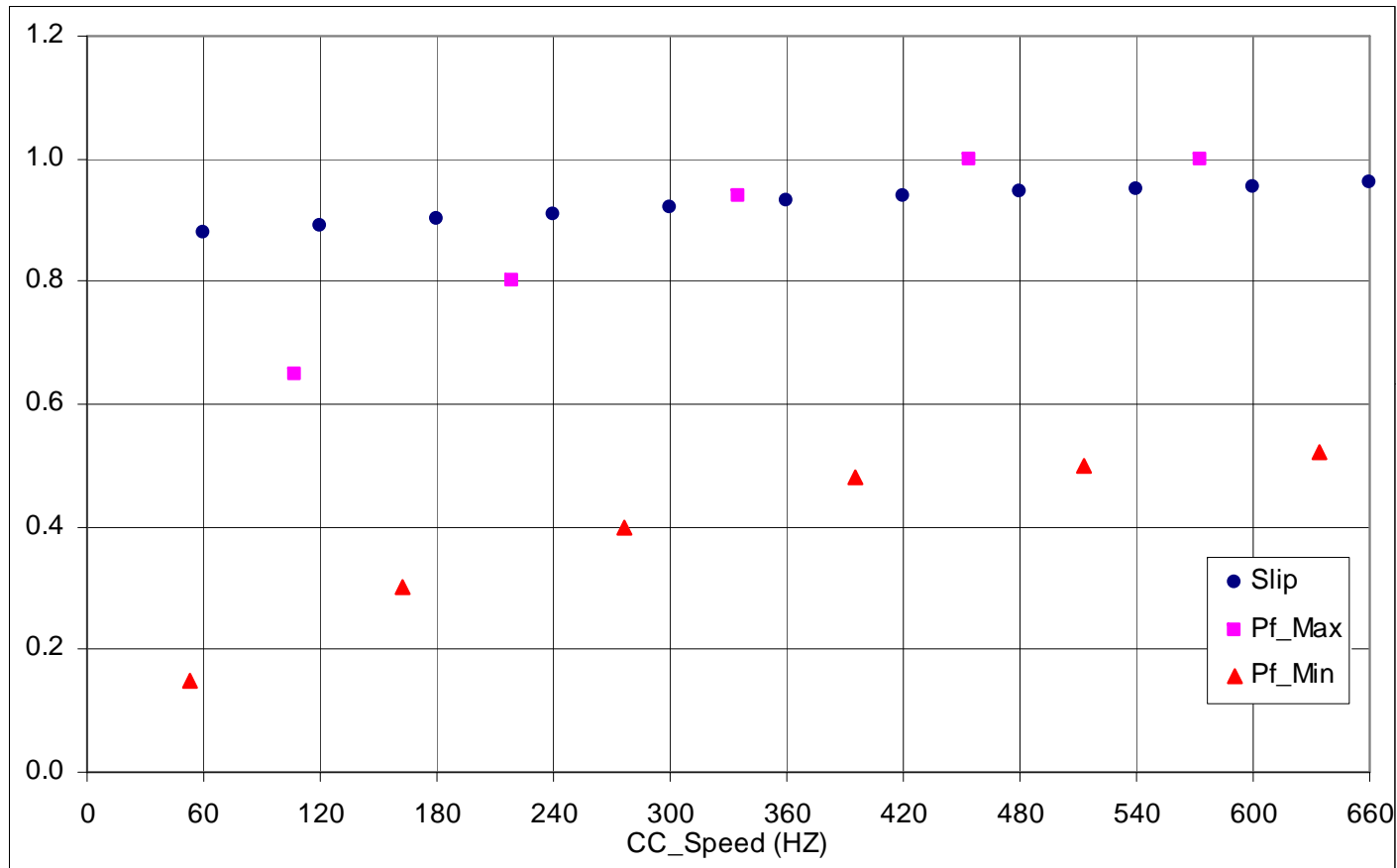

Figure 7.3.4: The minimum and maximum PF with respect to speed



Operated by the Jefferson Science Associates for the U.S. Dept. of Energy



Helium Refrigeration Systems for Below 4.2 K Operations (Cont.)

Type-3: Cold Compressor System (cont.)

The minimum and maximum PF with respect to the motor (cold compressor) speed are presented in Figure 7.3.4. Both the min and max PF's are periodic at approximately 120HZ intervals and at 60HZ apart from each other. In the above graph, another curve showing the slip is plotted and is defined as the relative speed at which the lagging PF peak (min or max) occurred with respect to the 60HZ multiple. The PF peak occurred at the product of the slip and the 60HZ multiple. As the speed increased, the PF and the slip improved and the peaks occurred closer to the 60HZ multiples. The min and max PF's are clearly influenced by the standard 60HZ power supply frequency.



Operated by the Jefferson Science Associates for the U.S. Dept. of Energy



Helium Refrigeration Systems for Below 4.2 K Operations (Cont.)

Type-3: Cold Compressor System (cont.)

Initial thoughts are:

may be the result of the physical combinations of passive and active electronic components in the output section of the drive and their characteristic frequency responses.

The output of the drive may be largely affected by the resonance tune of the electronics and their signal response at various frequencies.

The reasons for this behavior and the ways to improve the minimum PF for these variable frequency drives is of continued interest.

Attempts to find a device that is compatible with the output of the variable frequency drive that will correct for variable PF over the wide operating frequency range has not successful to date, but that effort is continuing.



Operated by the Jefferson Science Associates for the U.S. Dept. of Energy



Helium Refrigeration Systems for Below 4.2 K Operations (Cont.)

Type-3: Cold Compressor System (cont.)

- It is strongly believed that the pump downs can be accomplished with constant design speed (gear) ratios, if the minimum PF is brought close to the maximum. This will simplify the pump down path selections and provide a more robust cold compressor operation. The PF improvement can also help the turn down range for these systems and thus improve the overall system efficiency over a large operating range
- The Carnot specific power for this (Type-3) process is

$$= [4381] \text{ w/(g/s)} / 20 \text{ w/(g/s)}$$

$$= \sim 220 \text{ w/w}$$



Helium Refrigeration Systems for Below 4.2 K Operations (Cont.)

Type-3: Cold Compressor System (cont.)

Advantages:

- **Least possibility for contamination, since there are no sub-atmospheric connections at the warm end**
- **High efficiency at and near the design point operating conditions**
- **Very reliable system**
- **Pressure drop on the low pressure side of the cold box is not the limiting case**
- **Require less compressor floor space, since the displacement required for the sub-atmospheric volume gas is reduced by compression at low temperature**

Disadvantages:

- **Limited commercially available cold compressor options**
- **Increases the 4.5K system capacity required**
- **Higher capital cost: cold compressors (presently)**
- **Higher operating costs at reduced capacity (poor turn-down)**
- **Slower to reach the system operating conditions**



Helium Refrigeration Systems for Below 4.2 K Operations (Cont.)

Type-4: Hybrid systems

The Type-4 process can benefit from design trade offs between the Type-2 and Type-3 systems. This option draws a balance between the cold compressor input work to the 4.5K system and the overall process efficiency.

Figures 7.4.1 (a) and (b) present two variations; many other process options depending on the other constraints are available for this hybrid process concept.

The Tore-Supra system (300 W @ 1.75K) [16] & [17] was designed with the Type-4 concept.

The CERN LHC cold compressor systems are also of this type; where the warm compressors assist the cold compressors in achieving the total pressure ratio required.



Helium Refrigeration Systems for Below 4.2 K Operations (Cont.)

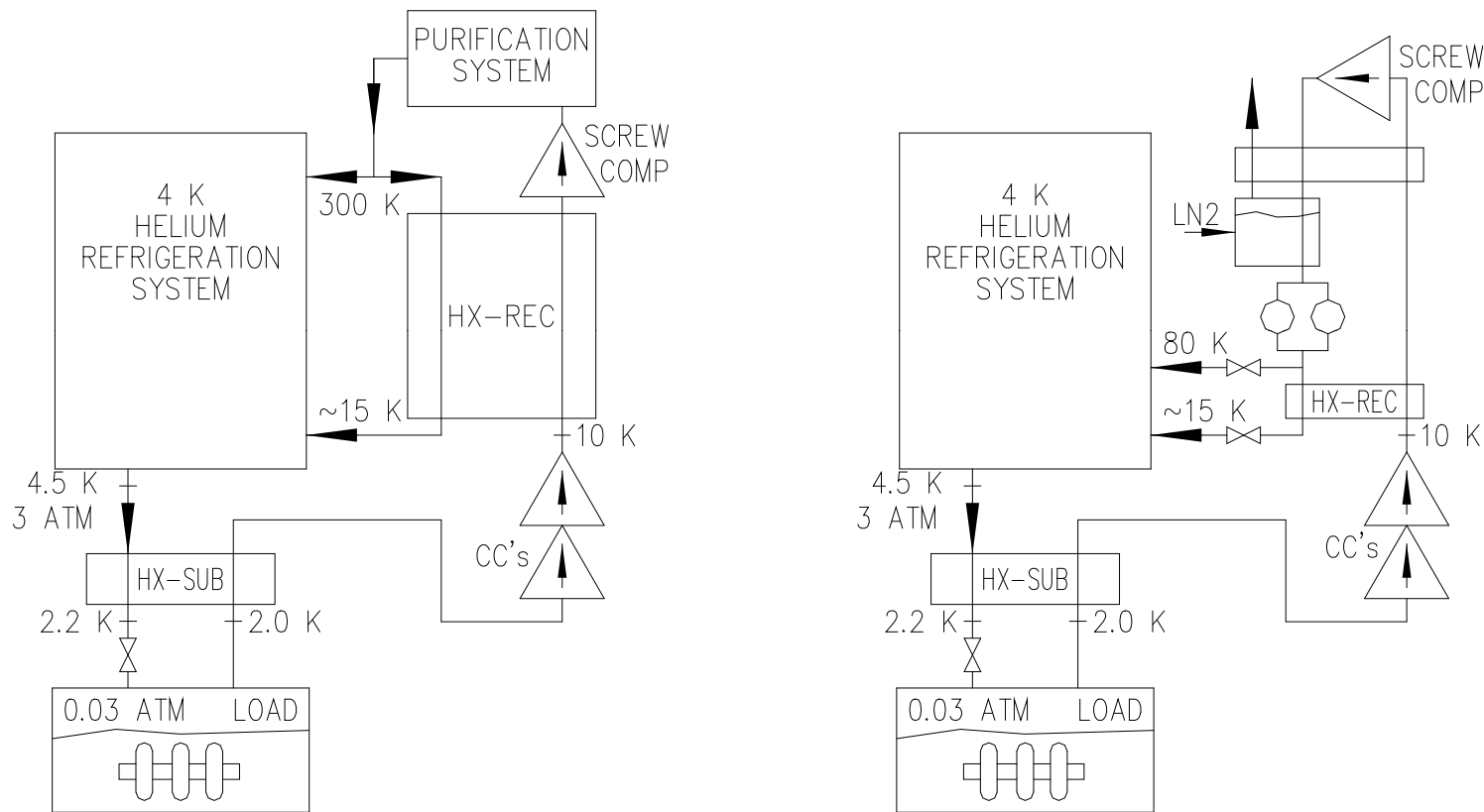

Figure: 7.4.1 A Hybrid Concept



Helium Refrigeration Systems for Below 4.2 K Operations (Cont.)

The Carnot specific power for this (Type-4) process is

$$= \left[(0.1 \cdot 6830) + (0.9 \cdot 3628) + (2.077 \cdot 300 \cdot \ln \{1/0.25\}) \right] \text{ w/(g/s)} / 20 \text{ w/(g/s)}$$

$$= [683 + 3265 + 864] / 20 = \sim 240 \text{ w/w}$$

The recovery heat exchanger (HX-REC) contributes to pressure drop and its sensitivity is as given in Type-4d calculation.

The Carnot specific power for Type-4d is

$$= \left[(0.1 \cdot 6830) + (0.9 \cdot 3628) + (2.077 \cdot 300 \cdot \ln \{1/0.20\}) \right] \text{ w/(g/s)} / 20 \text{ w/(g/s)}$$

$$= [683 + 3265 + 1003] / 20 = \sim 248 \text{ w/w}$$



Helium Refrigeration Systems for Below 4.2 K Operations (Cont.)

Type-4: Cold Compressor System (cont.)

Advantages:

- Pressure drop on the low pressure side of the cold box is not a limiting case
- Can add additional system capacity by adding expanders and compressors to the sub-atmospheric cold box system
- Easy to pump down and reach the operating conditions
Can reduce the system capacity (turn down) efficiently

Disadvantages:

- Susceptible to air leaks at the warm end that can contaminate the system
- Refrigeration capacity for cold compressor compression work still needs to be supplied by the 4 K system capacity
- Sub-atmospheric warm compressors with large pressure ratios are less efficient and can also lead to air leak contamination
- More compressor room floor space is required to handle the low pressure helium gas volume



Helium Refrigeration Systems for Below 4.2 K Operations (Cont.)

<u>Typical Expected values:</u>				
	2K Process Specific Power	Assumed Carnot Eff. of support refrigerator	Overall Specific Power	Overall Carnot Efficiency
	W / W		W / W	
Type-1 (a)	600	0.1	6000	0.027
Type-1 (b)	450	0.1	4500	0.036
Type-2	280	0.2	1400	0.114
Type-2 (c)	284	0.19	1495	0.107
Type-3	220	0.25	880	0.182
Type-4	240	0.24	1000	0.160
Type-4 (d)	248	0.23	1078	0.148



Helium Refrigeration Systems for Below 4.2 K Operations (Cont.)

Summary

- The nominal overall specific work (total input power to refrigeration power, W/W) and efficiency for these various processes is compared
- It is important recognize the over 2K system efficiency strongly depends on the 4K plant efficiency
- The approximate overall specific power and Carnot efficiency for system sizes *typical for the Type* and the efficiency of the *4K refrigerators typically used* with the effect of the minor modifications in each (to indicate the efficiency penalty due to modification) are given in the following table 7.5.1



8. Typical Helium Cryogenic System and its Basic Components

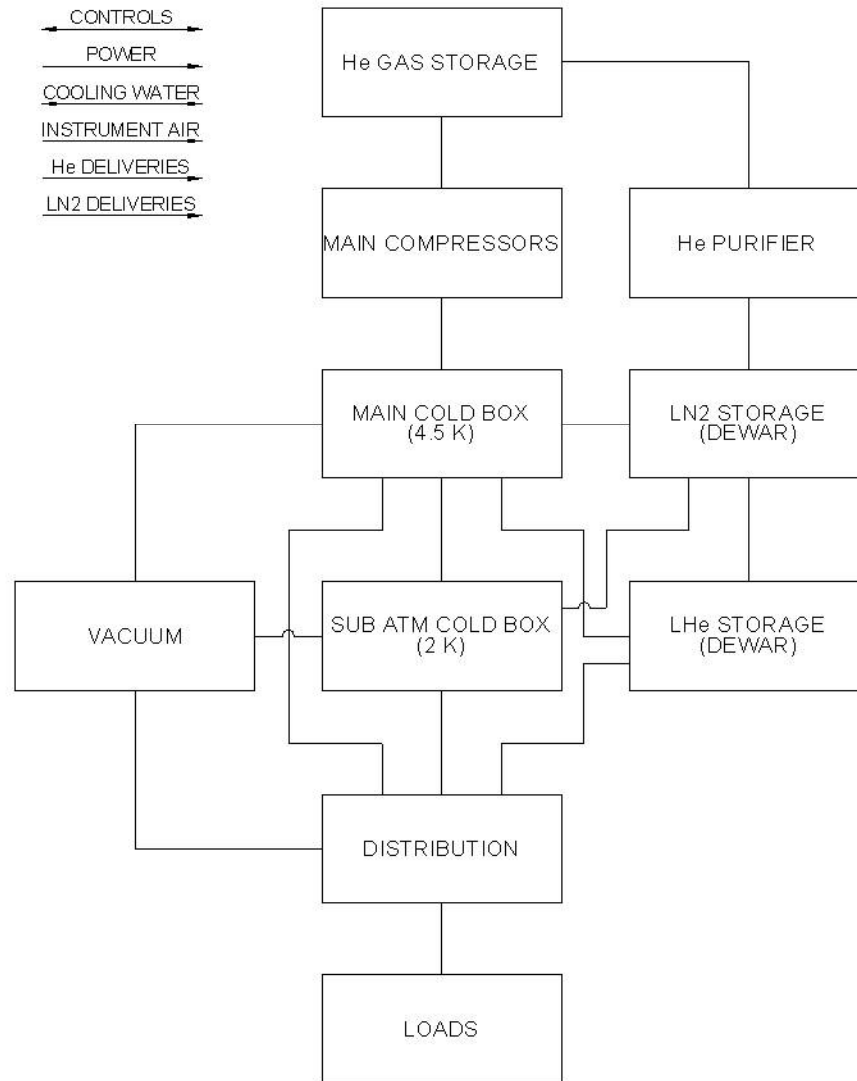

Typical Helium Cryogenic System and its Basic Components (Cont.)

Compressor System

- Two stage compression systems are common
- Three stage compression systems are used where the efficiency (operating cost) is more important

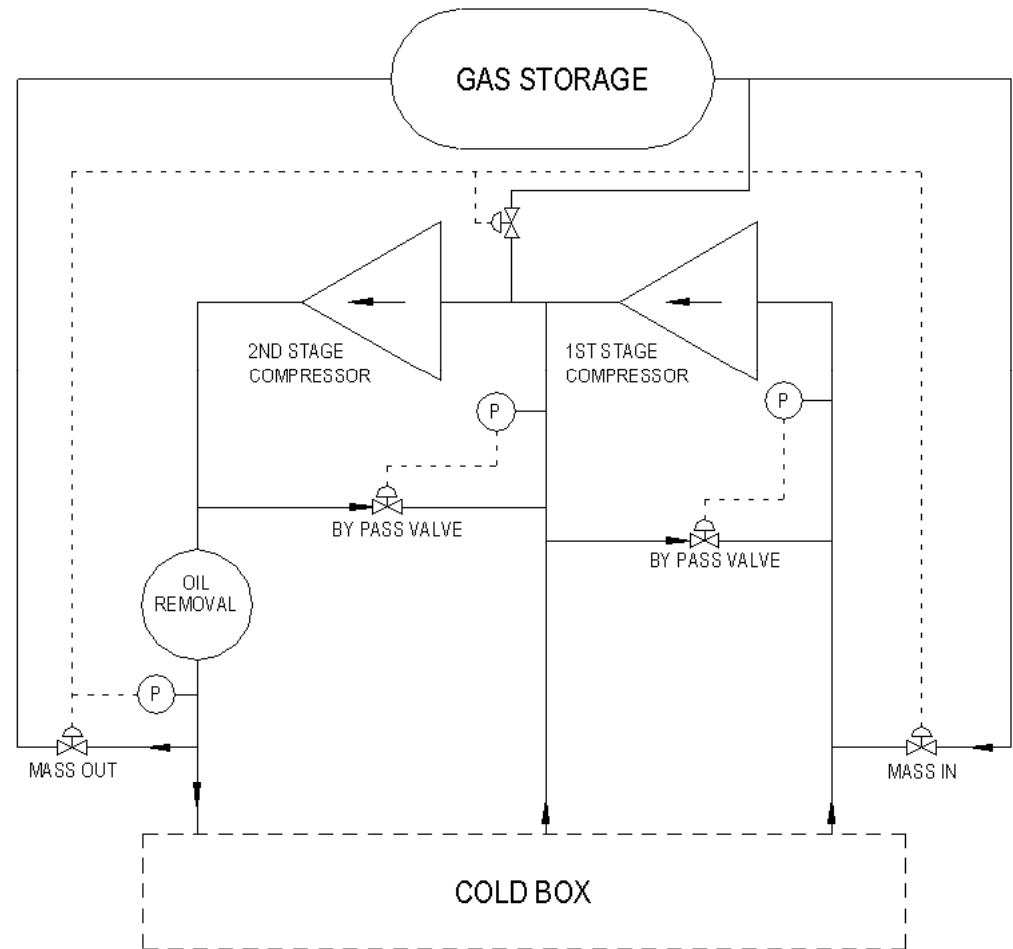

Typical Helium Cryogenic System and its Basic Components (Cont.)

Compressor System

- **The compressor provides the helium circulation to transfer heat from the low temperature to the environment (cooling tower)**
- **The compressor converts mechanical energy into helium gas available energy (exergy) by compression from low to high pressure and the removal of the heat of compression to the environment in an after-cooler, reducing the entropy (increasing the available energy) of the gas**
- **This available energy present in the gas is the source of the refrigeration provided to the load and process associated losses: heat exchangers, expanders, heat leaks and pressure drops**



Typical Helium Cryogenic System and its Basic Components (Cont.)

Compressor System

- **Reciprocating compressors**
 - Have most often been used in small systems
- **Screw compressors**
 - The oil injected screw compressor is a positive displacement rotary machine with minimal vibration that can readily handle helium's high heat of compression
 - The large capacity and especially the reliability and of oil flooded rotary screw compressors have practically replaced the reciprocating compressors in modern helium systems



Operated by the Jefferson Science Associates for the U.S. Dept. of Energy



Typical Helium Cryogenic System and its Basic Components (Cont.)

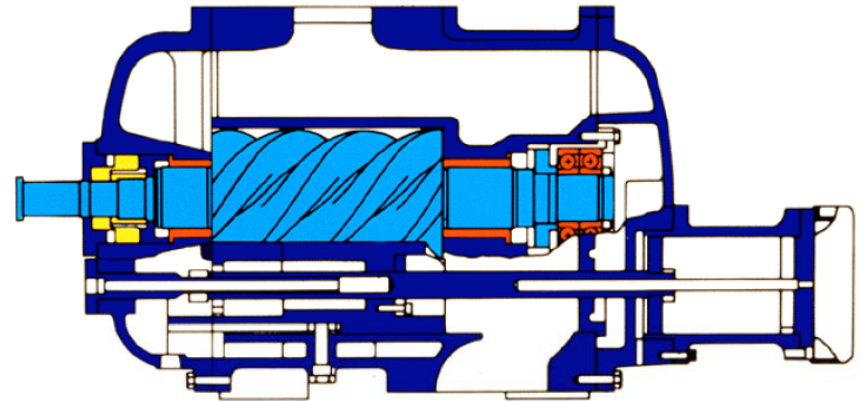
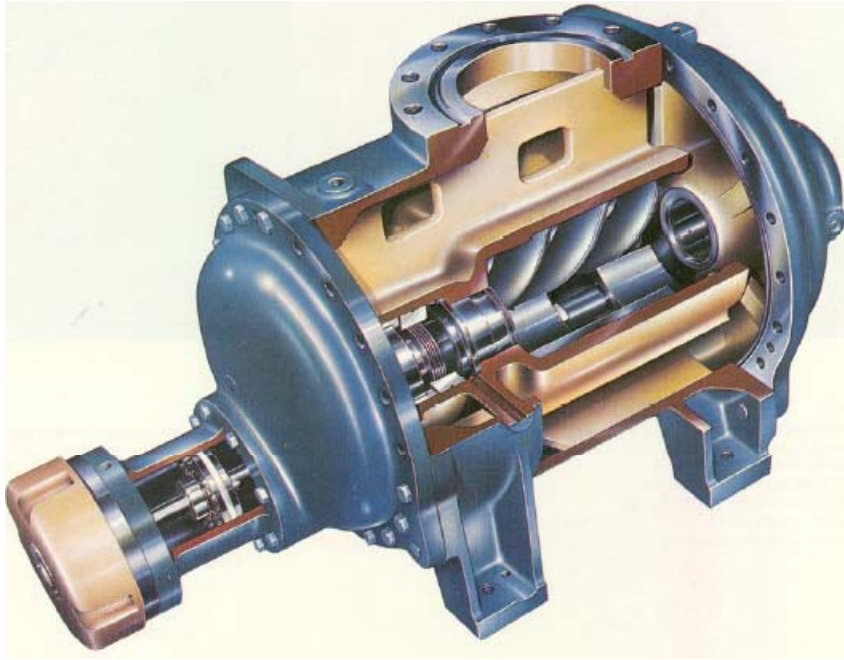

Screw Compressor views

(Courtesy of Howden compressors)



Operated by the Jefferson Science Associates for the U.S. Dept. of Energy



Typical Helium Cryogenic System and its Basic Components (Cont.)



Screw Compressor Operation

(Courtesy of Howden compressors)



Operated by the Jefferson Science Associates for the U.S. Dept. of Energy



Typical Helium Cryogenic System and its Basic Components (Cont.)

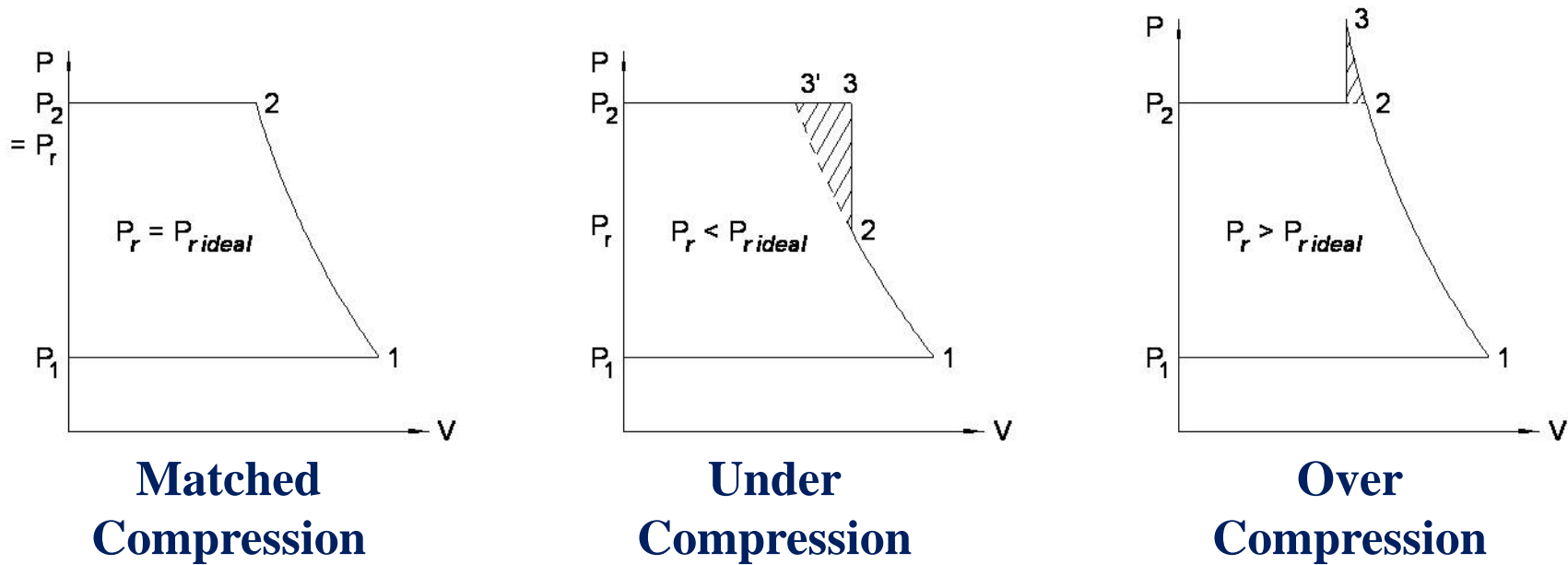

Figure 8.1.1b: Effect of built in volume ratio on the compression process



Operated by the Jefferson Science Associates for the U.S. Dept. of Energy



Typical Helium Cryogenic System and its Basic Components (Cont.)

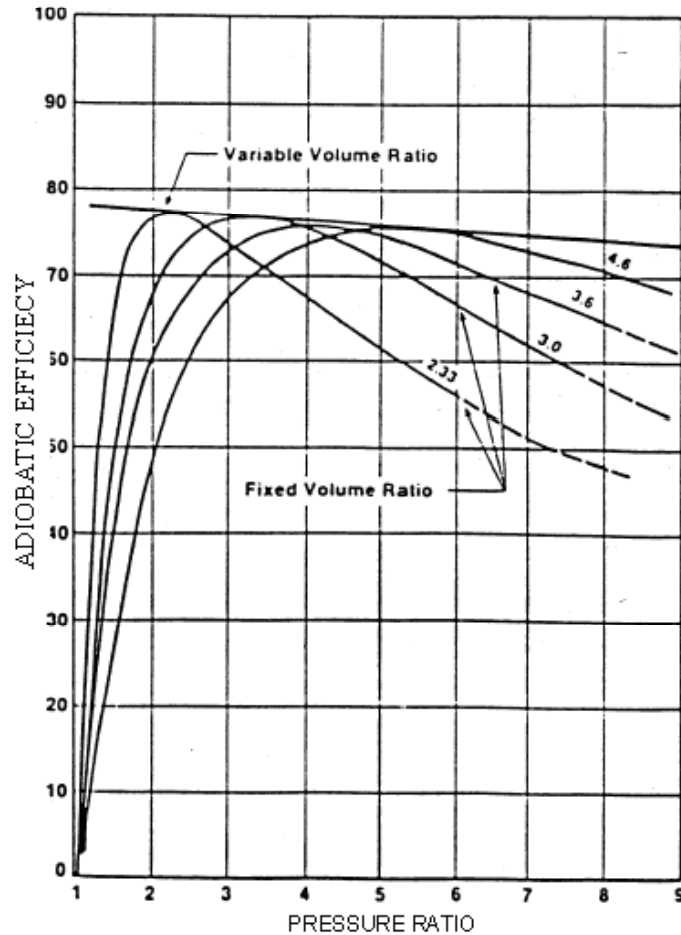

Effect of pressure ratio vs. efficiency for various volume ratios

Effect of input power vs. slide valve position

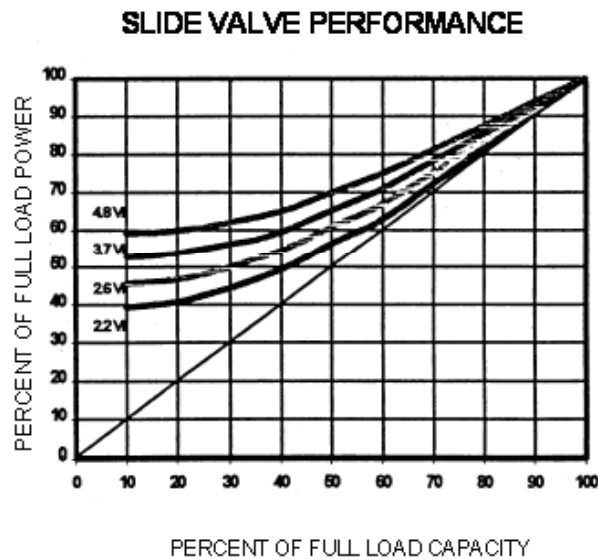

Operated by the Jefferson Science Associates for the U.S. Dept. of Energy



Thomas Jefferson National Accelerator Facility



Office of Science
U.S. Department of Energy

Typical Helium Cryogenic System and its Basic Components (Cont.)

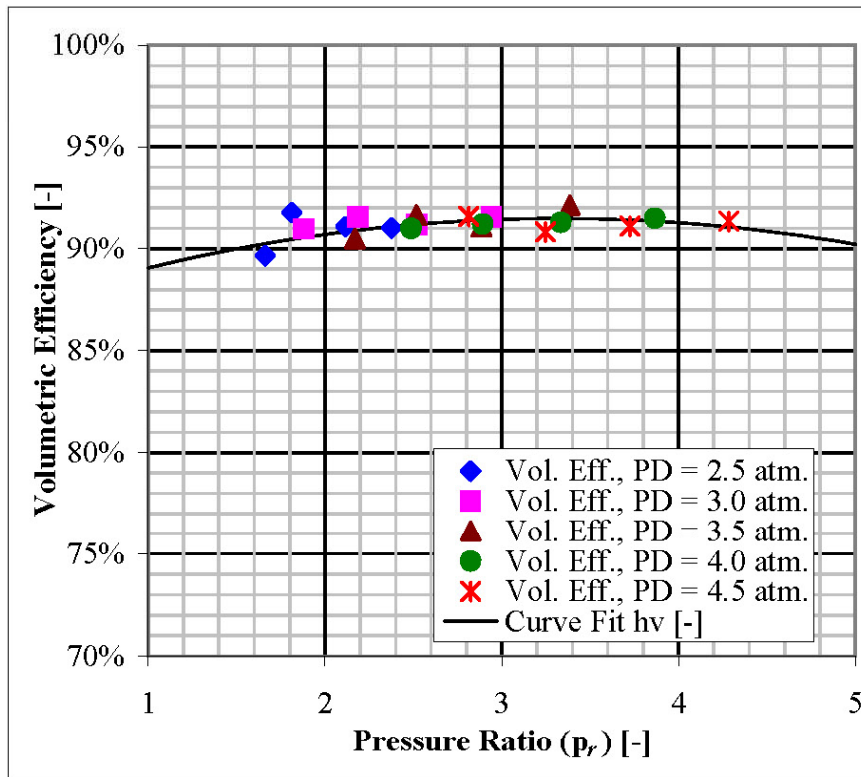

SSCL 1st Stage Volumetric Efficiency

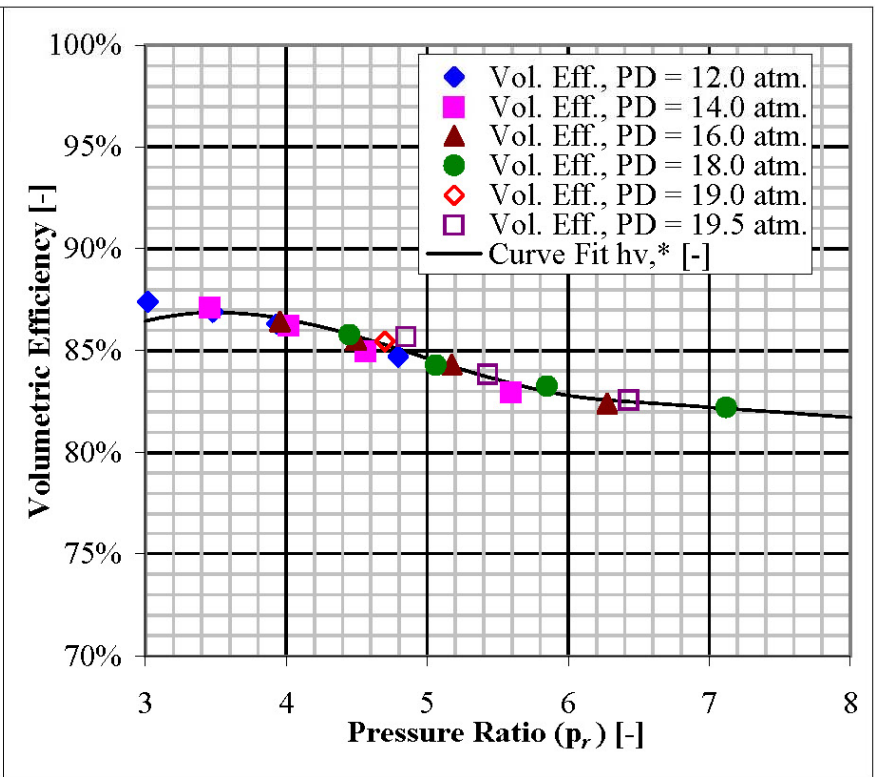

SSCL 2nd Stage Volumetric Efficiency



Typical Helium Cryogenic System and its Basic Components (Cont.)

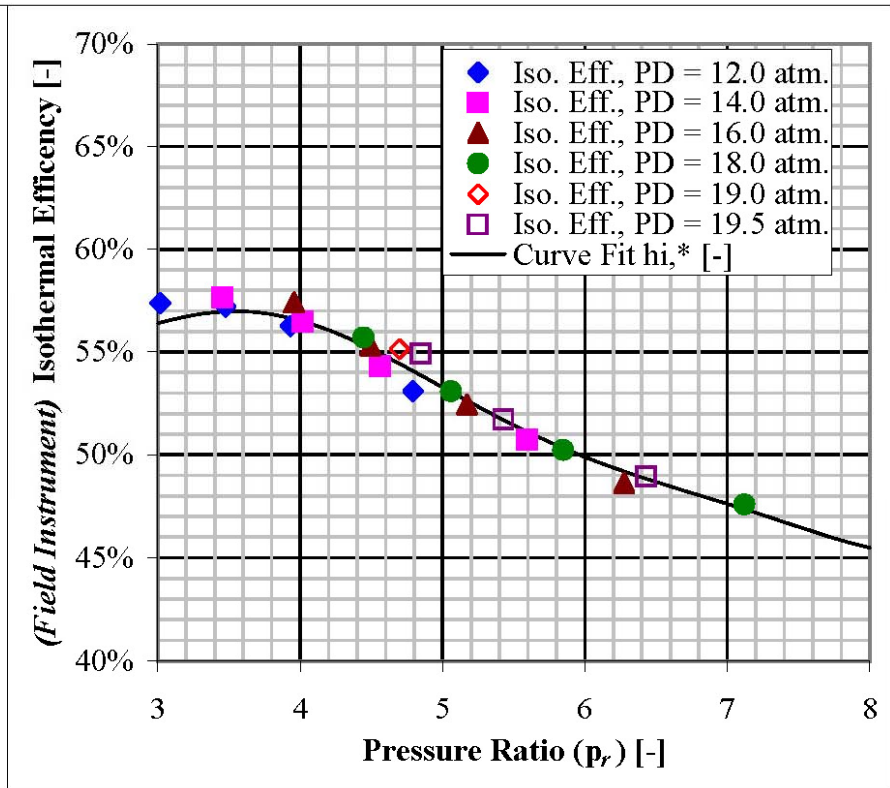
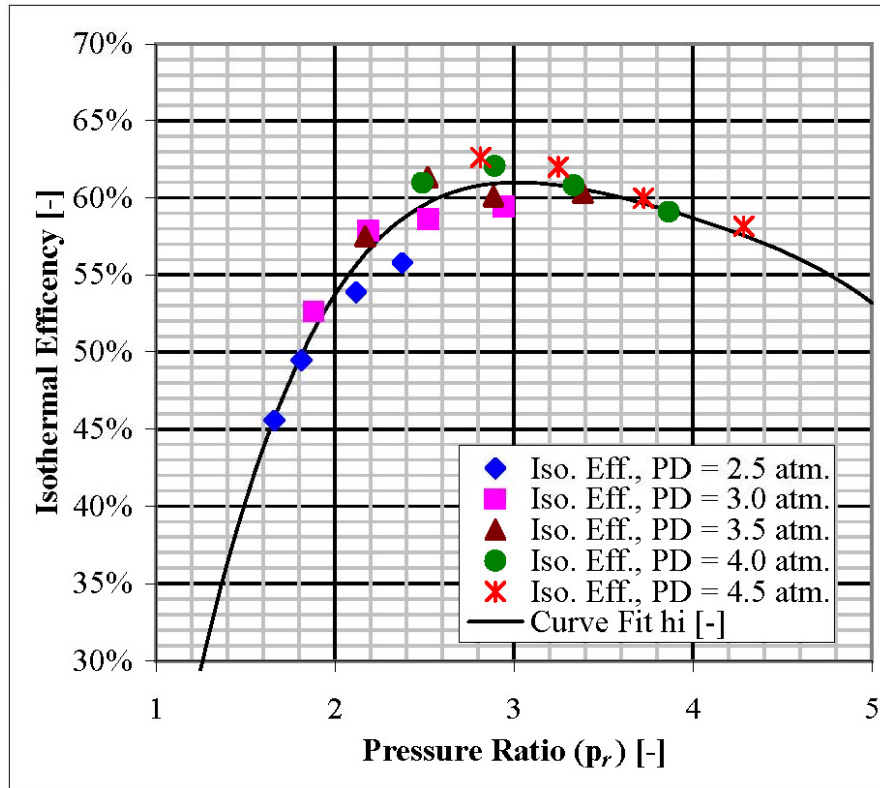

SSCL 1st Stage Isothermal Efficiency

SSCL 2nd Stage Isothermal Efficiency



Operated by the Jefferson Science Associates for the U.S. Dept. of Energy



Typical Helium Cryogenic System and its Basic Components (Cont.)

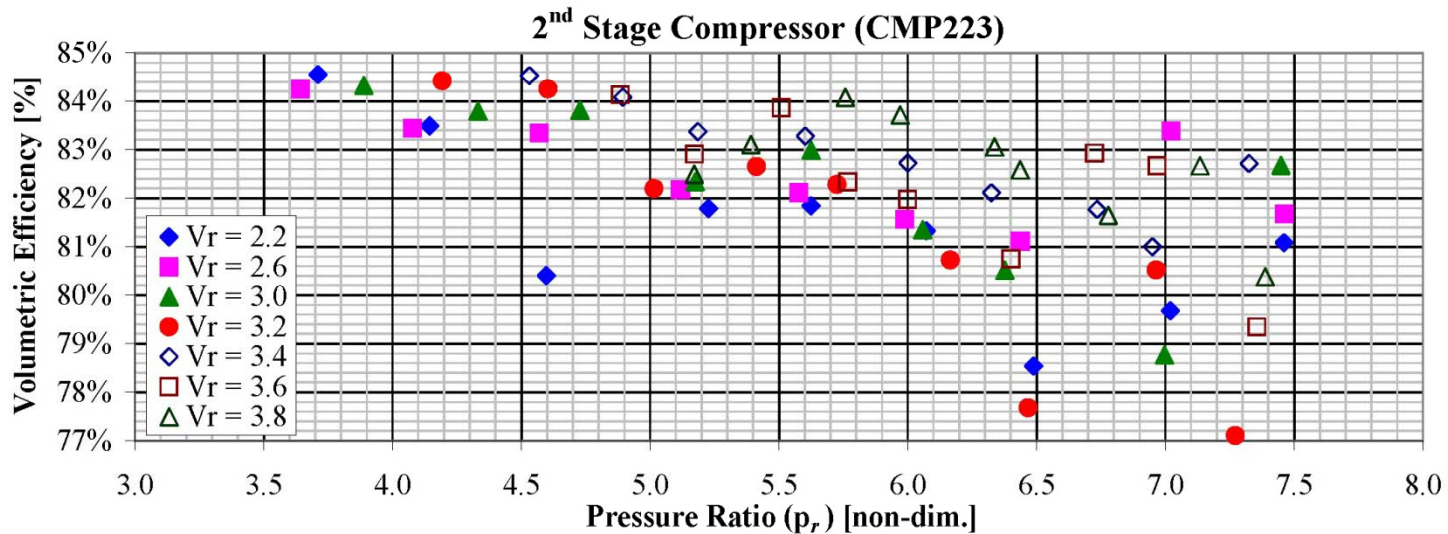
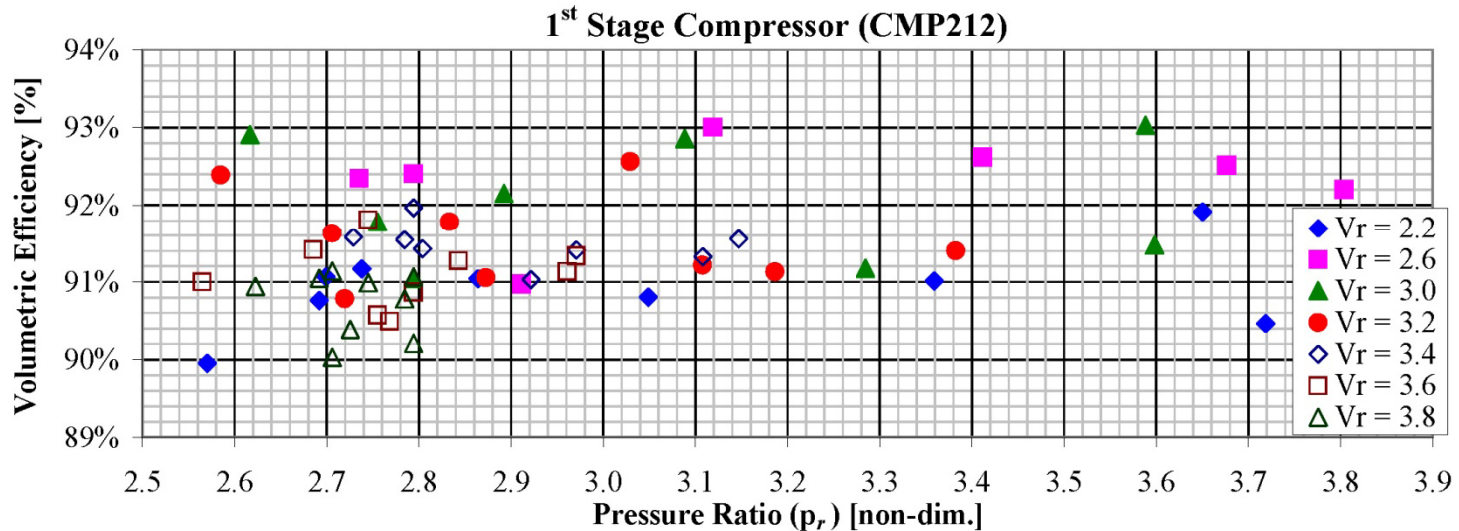

Operated by the Jefferson Science Associates for the U.S. Dept. of Energy



Typical Helium Cryogenic System and its Basic Components (Cont.)

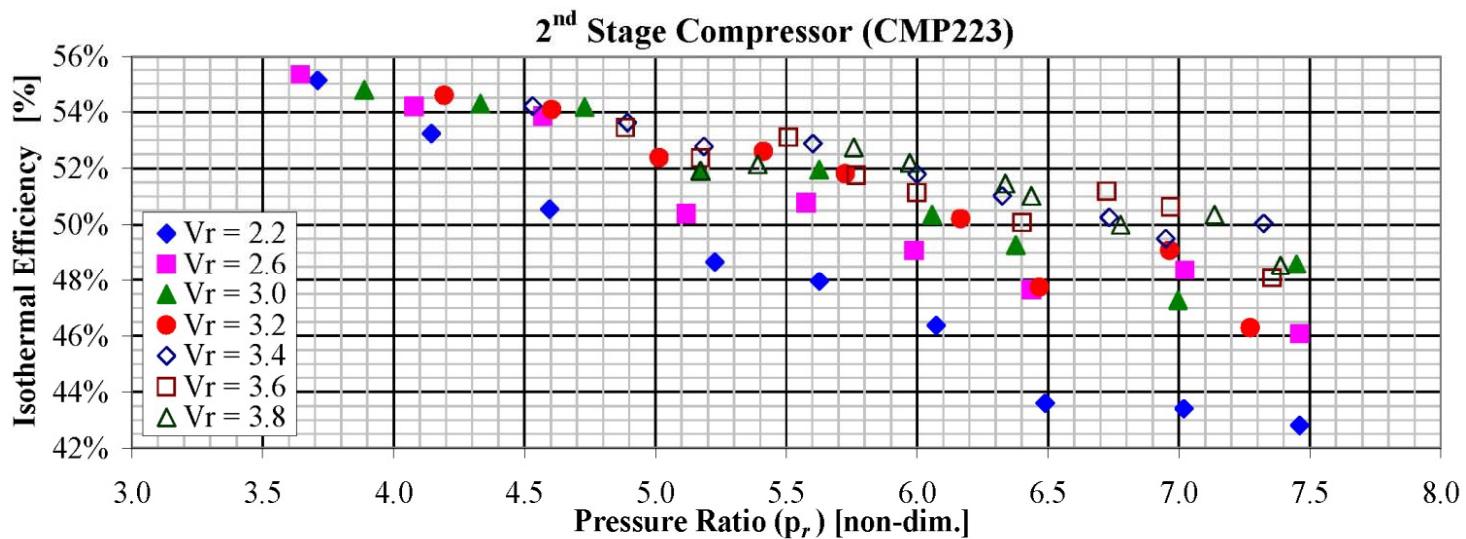
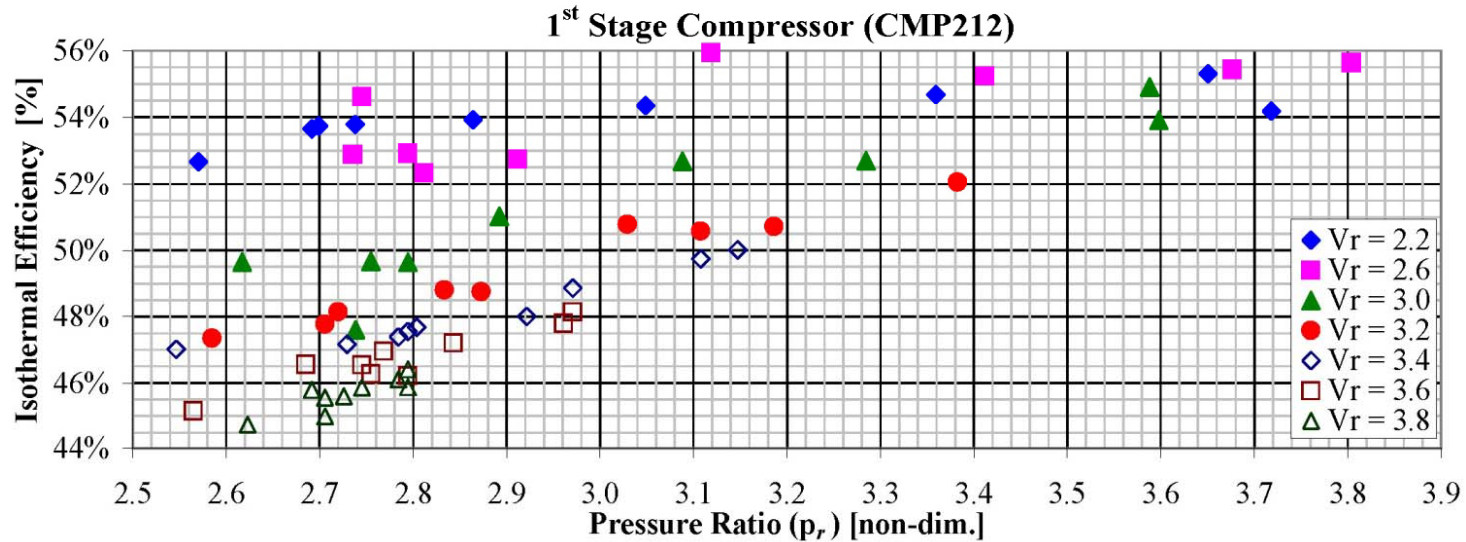

Operated by the Jefferson Science Associates for the U.S. Dept. of Energy



Typical Helium Cryogenic System and its Basic Components (Cont.)

Compressor System

- Ideally the built in volume ratio should match the required pressure ratio as shown in the first figure
- It is recommended not to select compressors having a higher compression ratio than required, i.e. *it is better to under-compress than to over-compress in the compressor*
- Some times slide valve position control is used for capacity control – *this is not recommended*
- The gas management system is to maintain the system pressures within the allowable minimum and maximum to satisfy the system capacity and oil removal constraints



Operated by the Jefferson Science Associates for the U.S. Dept. of Energy



Typical Helium Cryogenic System and its Basic Components (Cont.)

Compressor System

- For helium systems, the pressure ratio required is too large to be efficiently provided by a single stage machine
- There are many arrangements available for multi-stage compression and they include staged single machines, as well as, compound machines to save the cost of the motor and its starter
 - *Development of two compressors connected on either end of a motor*
- The multi-stage compression efficiency is not attained if the gas is not cooled to ambient temperature after each compression stage
- The volumetric and isothermal efficiencies are very important parameters for the overall system process design and for sizing all the compressor skid components; mainly, the compressor, motor and the coolers



Operated by the Jefferson Science Associates for the U.S. Dept. of Energy



Typical Helium Cryogenic System and its Basic Components (Cont.)

Compressor System – Oil Pumps & Oil Separation

- **Oil used in the compressors serves several purposes**
 - **Small fraction is used for lubricating the rotating parts**
 - **Most used to keep the discharge temperature within the material limits**
 - **Also helps to prevent the gas from leaking back to the suction**
- **Oil used for lubrication, screw compressors can use**
 - **external oil pumps or,**
 - **discharge pressure**
- **However, external oil pumps are generally less reliable**



Typical Helium Cryogenic System and its Basic Components (Cont.)

Compressor System – Oil Cooler & Helium Gas After-Cooler

- Input power to compressor motor power is finally dissipated into environment through
 - oil cooler, comprising ~ 70 to 90% of total
 - after-cooler (for the remainder), comprising ~10% to 30% of total
- Generally, a double tube sheet design with an air gap between them is used to prevent a water leak into the process streams



Typical Helium Cryogenic System and its Basic Components (Cont.)

Compressor System – Electric Motor, Starter & Controls

- Nominally, 480V is used for ≤ 250 HP
- Nominally, 4160V is used for > 250 HP
- Screw compressors require a high starting torque
 - Starting torque requires a 70% voltage tap
 - ‘across-the-line’ starting used to address this higher torque
 - the magnetization current and starting torque require ~6 times the full load amps for a short duration during startup of a fully unloaded compressor.
- The compressors should not be started twice in less than half an hour to allow dissipation of the heat generated from the starting current in the motor windings



Typical Helium Cryogenic System and its Basic Components (Cont.)

Compressor System – Final Oil Removal System

- i.e., oil coalescers and carbon bed
- Purifies the helium supply to the cold box
- Normally configured in a series of three to four stages of coalescers to achieve < 0.1 ppm
- Finally the activated carbon adsorber removes the impurities to the ppb level
- Nominal velocities used for the coalescer design to ensure proper separation, preventing re-entrainment
 - radial velocity ≤ 10 cm/s
 - annulus (axial) velocity of 10 cm/s
- Capacity of carbon to adsorb oil vapor depends upon:
 - Type and activation (moisture content) of the charcoal
 - Adsorption capacity (usually 1 to 2% by weight)
 - Length to diameter (L/D) ratio
 - generally designed for a $L/D > 3$



Typical Helium Cryogenic System and its Basic Components (Cont.)

Compressor System – Gas Management

Note: The impact of the gas management system should not be underestimated.

- The gas management determines the system operating pressure
 - it affects the utility usage and the reliability of the system
- Bypass valves can completely waste the input power (which can be many MW's) (e.g., when the compressor system fully bypasses the cold box)
- Leak of through these valves will,
 - reduce the system capacity (resulting in not having enough flow),
 - increase the required utilities and,
 - decrease the reliability by operating the system at an unnessecary higher pressure to meet the capacity requirement
- For efficient control of the system over the entire operating range, the gas management should be designed with floating pressure control
- A feedback from the load can be used for determining the required system charge for a given load
- As the load increases, the medium and high pressures float up to support the required system capacity



Operated by the Jefferson Science Associates for the U.S. Dept. of Energy



Typical Helium Cryogenic System and its Basic Components (Cont.)

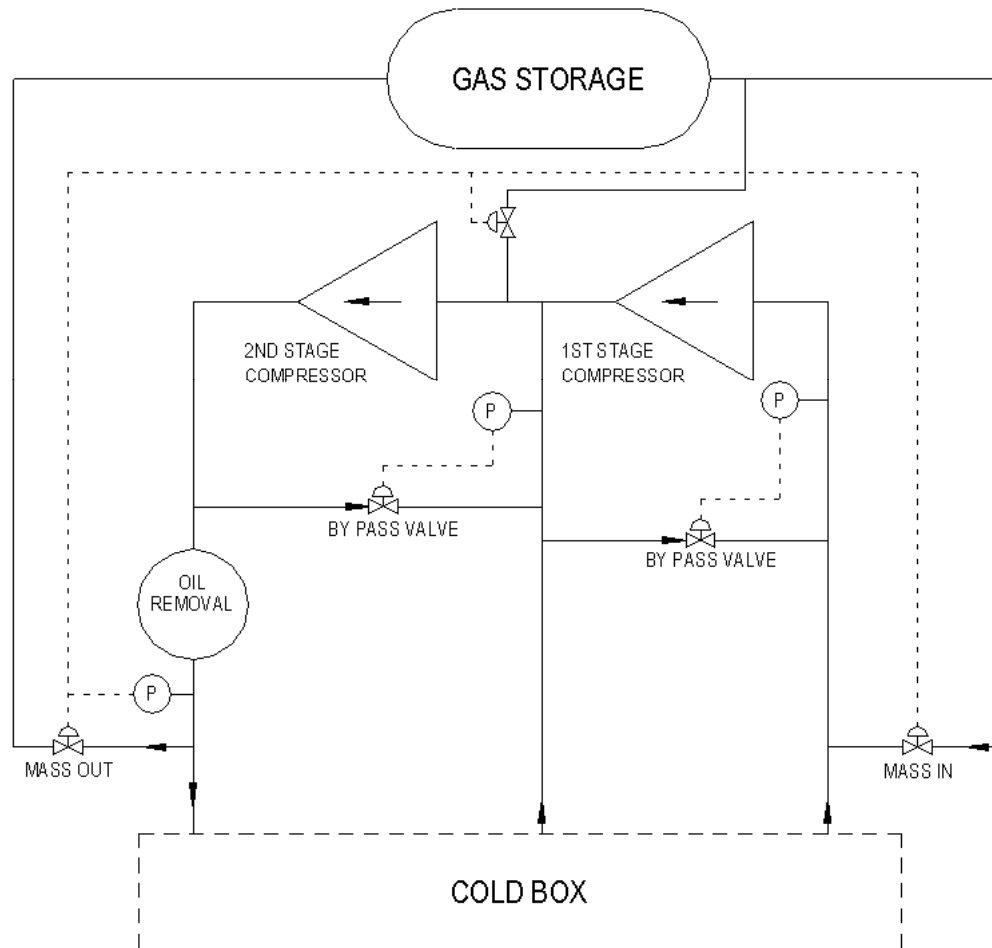

Operated by the Jefferson Science Associates for the U.S. Dept. of Energy



Typical Helium Cryogenic System and its Basic Components (Cont.)

Main Cold Box

- Contains,
 - Heat exchangers,
 - Expanders
 - Adsorbers
 - Valves
 - Instrumentation, etc.



SNS 4.5-K Cold Box



Operated by the Jefferson Science Associates for the U.S. Dept. of Energy



Typical Helium Cryogenic System and its Basic Components (Cont.)

Main (or 4.5-K) Cold Box

- The main cold box contains all components (heat exchangers, expanders, adsorbers, valves, instrumentation, etc.) required to produce 4.5 K helium refrigeration and liquefaction, along with any helium refrigeration for any required shield cooling
- Proper cool down and warm up lines with control valves should be provided at various temperature levels within the cold box on both high and low pressure sides of the HX stack
- The cold box should have well calibrated, proven instrumentation for pressure, temperature and flow at all the critical nodes for both component control and troubleshooting



Operated by the Jefferson Science Associates for the U.S. Dept. of Energy



Typical Helium Cryogenic System and its Basic Components (Cont.)

Cold Box – Heat Exchangers (HX)

- HX's cool the gas to low temperatures by utilizing the (un-required) cooling of the helium returning from the load
- In addition, the HX's help to place a finite number of expanders in the cycle; thereby making the cycle more efficient
- HX's should be installed in the vertical orientation with the warm end up; at least for 40K and lower
- Design is very important for both helium refrigerator and liquefier, though refrigerators require more HX surface area (UA) for a given Carnot capacity and system efficiency
- HX length is proportional to the NTU's required and the UA is governed by the capacity of the system



Typical Helium Cryogenic System and its Basic Components (Cont.)

Cold Box – Heat Exchangers

- **Great amount of care required in designing HX's with a high effectiveness; i.e., > 95%**
 - **In helium systems, some HX's are designed for an effectiveness of 98%**
- **Some of the parameters that influence the effectiveness are,**
 - **pressure drop distributions**
 - **Important to have very a low pressure drop in the nozzles compared to distributor**
 - **Likewise, distributor pressure drop should be low compared to the HX core to achieve proper flow distribution through the HX core**
 - **longitudinal conduction**
 - **external heat leak in to the HX's**



Typical Helium Cryogenic System and its Basic Components (Cont.)

Cold Box – Heat Exchangers

- For proper operation of HX's,
 - HX surface area and the flow area requirements (including the pressure drop constraints) must be sized for all the modes of operation
 - Pressure drop distributions for each stream and for each primary operation mode must be as follows to minimize flow mal-distribution (especially at reduced capacity modes):
 - a = Core pressure drop (atm)
 - b = Distributor pressure drop (atm)
 - c = Nozzle and header pressure drop (atm)
 - Require Ratio of $(a / b) > 3$ and,
 - Require Ratio of $(a + b) / c > 3$
- As a first choice, all HX's must be mounted in the cold box in the vertical oriented position with the warm end up as a first choice.



Typical Helium Cryogenic System and its Basic Components (Cont.)

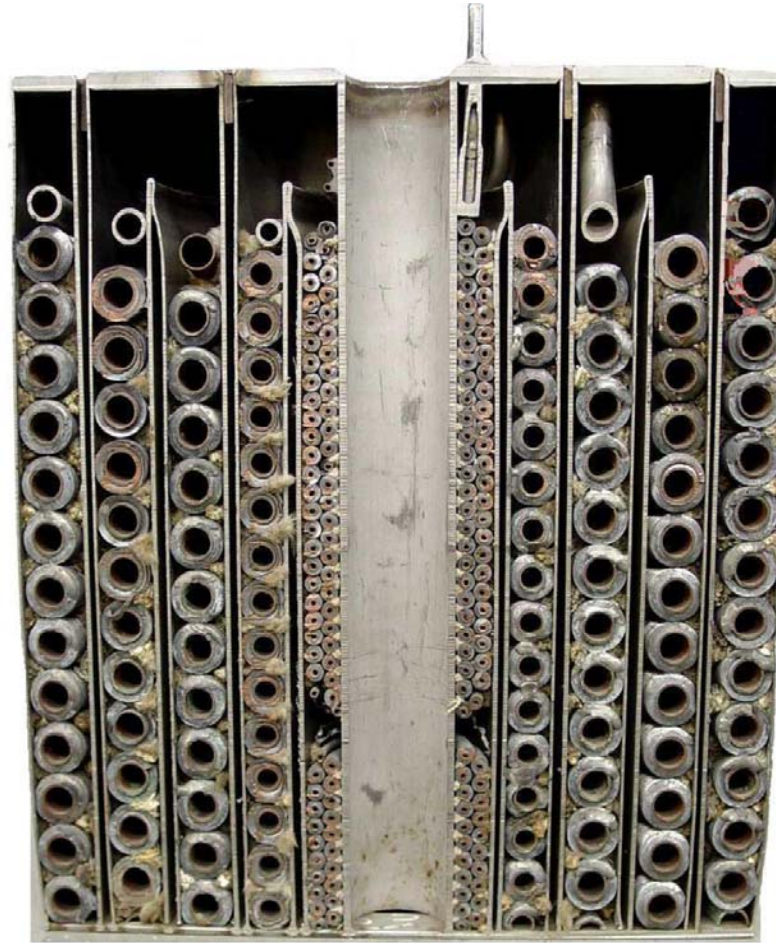

Fin tube heat exchanger

(Courtesy of CPS, Linde BOC Process Plants)



Operated by the Jefferson Science Associates for the U.S. Dept. of Energy



Typical Helium Cryogenic System and its Basic Components (Cont.)

Heat Exchanger - Types

- **Fin tube heat exchangers**
 - **Finned tube HX's are primarily used in small systems**
 - **Advantages:**
 - **Have a large surface area for a given volume resulting in a compact unit**
 - **Ability to nest successive HX's helps to minimize the radiation heat in-leak reaching lower temperature HX's**
 - **Disadvantage - not a true counter-flow design, since a full circle of the tube side is exposed to one shell side temperature**
- **Nylon sealing rope used in between the mandrel and the fin tubing**
 - **If not installed properly, flow can bypass tubes resulting in a drastic HX performance reduction; thereby causing a reduction in the system performance**
- **Ref. Appendix-E**



Typical Helium Cryogenic System and its Basic Components (Cont.)

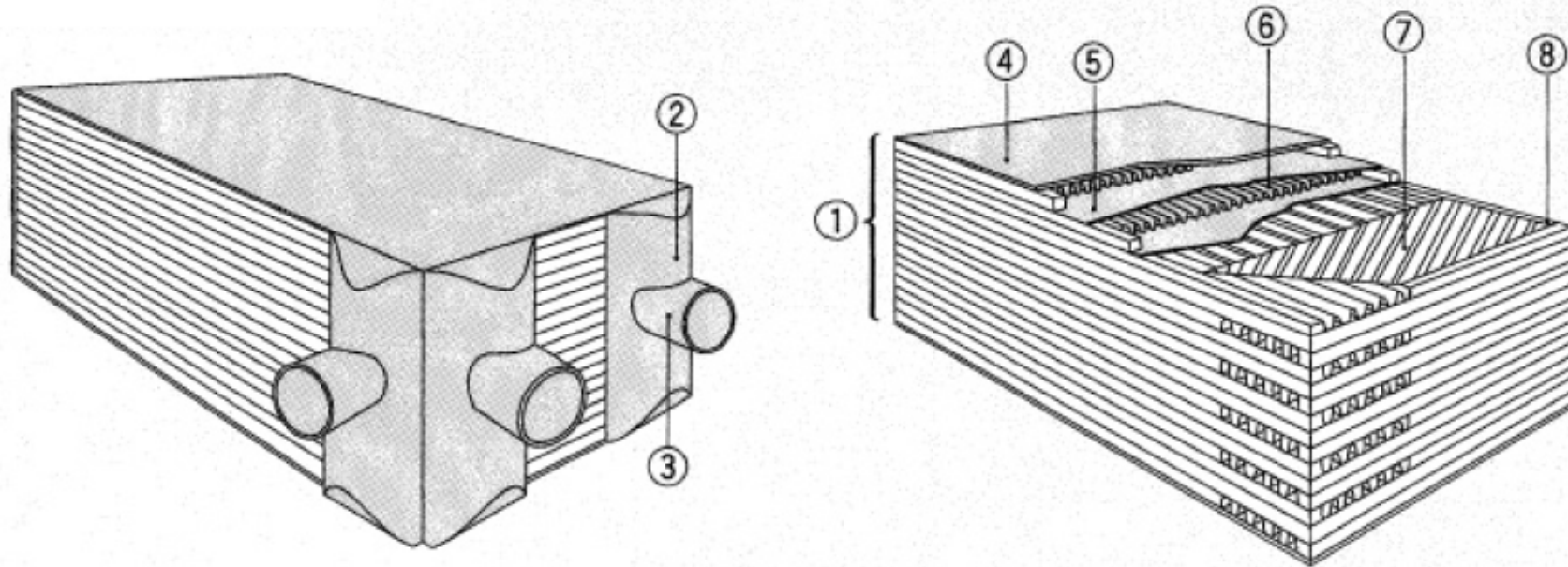

1.Block(Core)
2.Header

3.Nozzle
4.Cap Sheet(Side Plate)

5.Parting Sheet(Tube Plate)
6.Heat Transfer Fin(Corrugated Fin)

7.Distributor Fin
8.Side Bar(Spacer Bar)

Brazed aluminum heat exchanger
(Courtesy of Sumitomo Precision Products)



Operated by the Jefferson Science Associates for the U.S. Dept. of Energy



Typical Helium Cryogenic System and its Basic Components (Cont.)

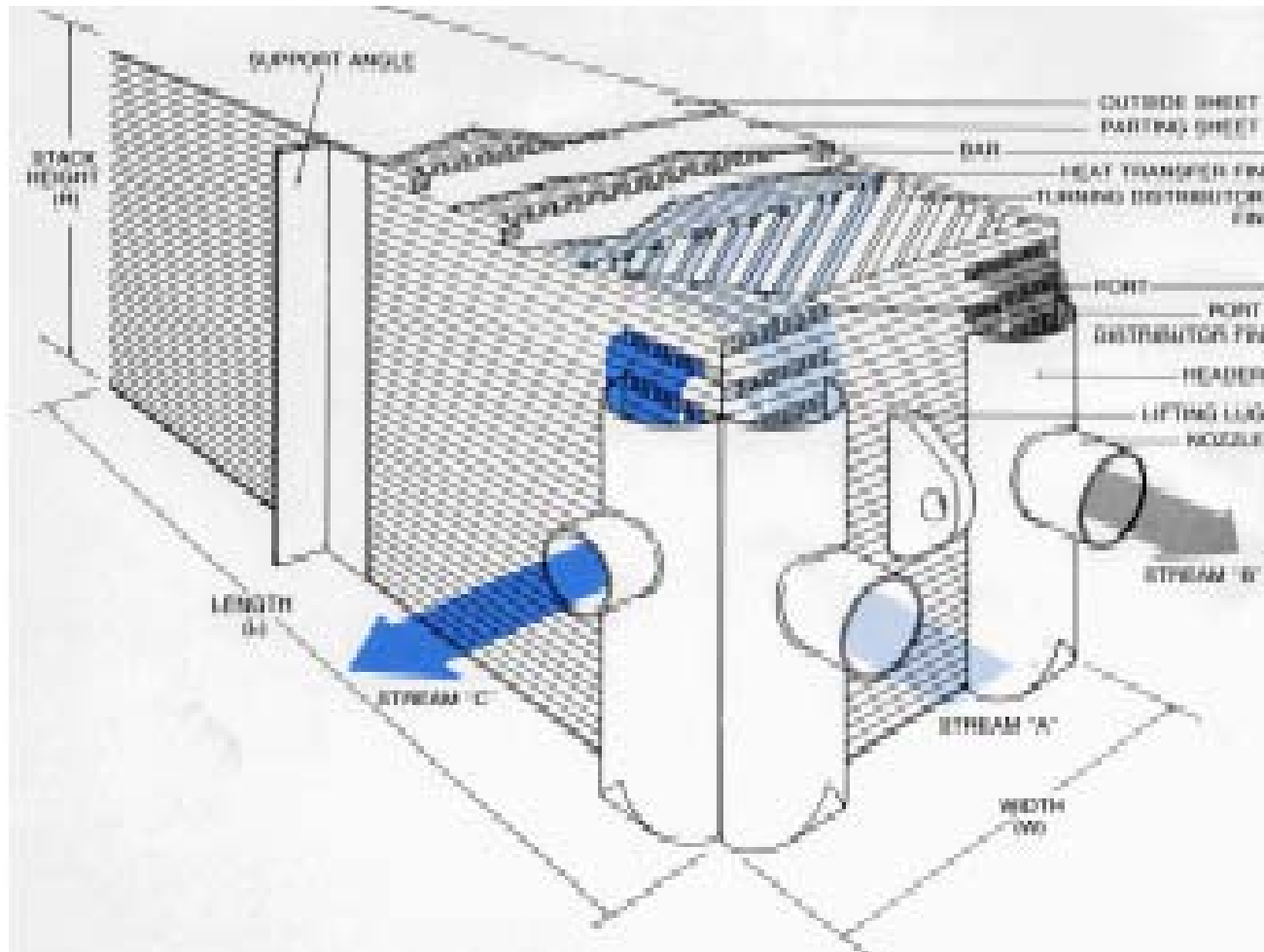

Operated by the Jefferson Science Associates for the U.S. Dept. of Energy



Office of Science
U.S. Department of Energy

Typical Helium Cryogenic System and its Basic Components (Cont.)

Heat Exchanger - Types

- **Brazed aluminum HX's**
 - Brazed Al HX's are used in medium to large capacity helium systems
 - Helium refrigerator/liquefier cold boxes most often use vacuum furnace brazed plate-fin HX's constructed to a leak rate of less than 10^{-8} mbar-liter/sec
 - These HX's have a large surface area with good heat transfer characteristics (fin selections) for a given volume, thus making them compact for a given duty
 - Longitudinal conduction effect should be properly addressed in the design to achieve high effectiveness
 - In multi-stream exchangers, the layering of streams is very important in addition to the other flow distribution effects as discussed earlier
 - Recommended ΔT in the nozzles at any end should not exceed 50K



Typical Helium Cryogenic System and its Basic Components (Cont.)

Heat Exchanger – Brazed Aluminum Type

Typical Design Data:

- Density of aluminum = 2.7 g/cm³ (2700 kg/m³)
- Density of aluminum HX = 1.4 g/cm³ (1400 kg/m³)
- Total surface area = 0.95-1.05 m²/kg
- 1 meter of active core length ~10 NTU's

- For helium cold box design, typical HX size (i.e., NTU's) that should be used:
 - 300-80K HX = 35 to 50
 - 80-20K HX's = 35 to 50
 - 20-4.5K HX's = 35 to 50

Note: HX length is proportional to the NTU's required and the UA is governed by the capacity of the system



Operated by the Jefferson Science Associates for the U.S. Dept. of Energy



Typical Helium Cryogenic System and its Basic Components (Cont.)

Cold Box - Expanders

- The expanders provide the refrigeration required at different cycle temperature levels
- In general, the more stages of expanders used in a cycle the more efficient the system
- Expander losses and their unused output power add to the necessary compressor power of the refrigeration cycle
- Practical helium refrigerators require a minimum of two expanders to produce the 4.5K from the 300K environment



Operated by the Jefferson Science Associates for the U.S. Dept. of Energy



Typical Helium Cryogenic System and its Basic Components (Cont.)

Cold Box - Expanders

- **Expander efficiency is very important for both the helium refrigerator and liquefier, but the number of expander stages is more important to the liquefier**
- **For a given number of cold box expansion stages, a higher expander temperature ratio leads to a higher cold box efficiency due to,**
 - **Producing more refrigeration for unit mass flow,**
 - thus requiring a lower mass flow rate through the cold box,
 - which reduces the HX size and exergetic losses
 - **Absorbing the load (liquefaction and other exergetic losses) at a higher temperature by the refrigeration provided by the expanders**



Typical Helium Cryogenic System and its Basic Components (Cont.)

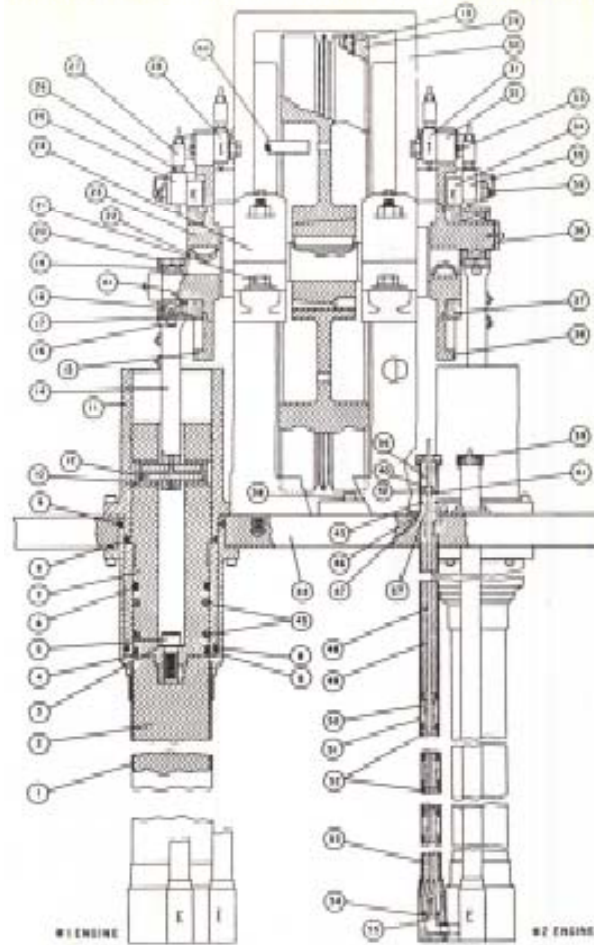

Figure 8.2.2a: Reciprocating expander
(Courtesy of CPS, Linde BOC Process Plants)



Operated by the Jefferson Science Associates for the U.S. Dept. of Energy



Typical Helium Cryogenic System and its Basic Components (Cont.)

Expanders – Types

- **Reciprocating expanders, are,**
 - **More suitable for small systems**
 - **Very efficient (75% to 85% observed) over a large pressure ratio**
 - **Provide a large temperature ratio (on the order of 2) for each expansion stage and thus result in a more efficient system for a given number of expansion stages**
 - **This in turn allows smaller HX's and compressor size for a given load; resulting in a compact system**
 - **Additionally, they are easy to maintain and are reliable for transient load operations**
 - **Require maintenance after roughly 5000 hours of operation**



Operated by the Jefferson Science Associates for the U.S. Dept. of Energy



Typical Helium Cryogenic System and its Basic Components (Cont.)

SULZER®
Cryogenic turboexpander
Self-acting gas bearing system

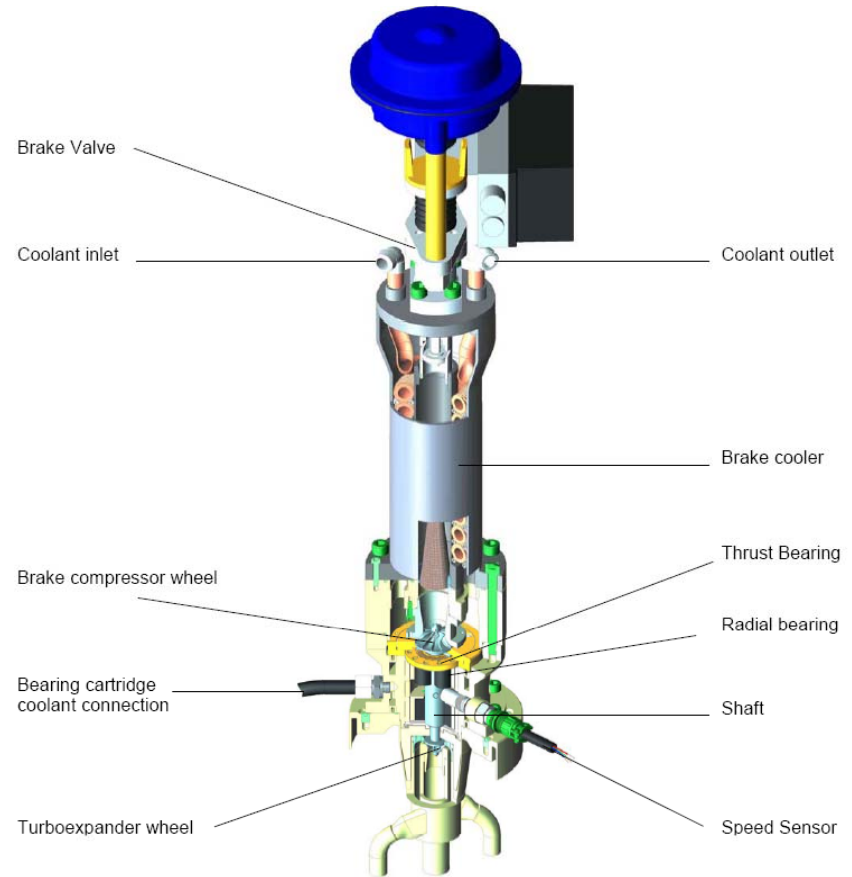
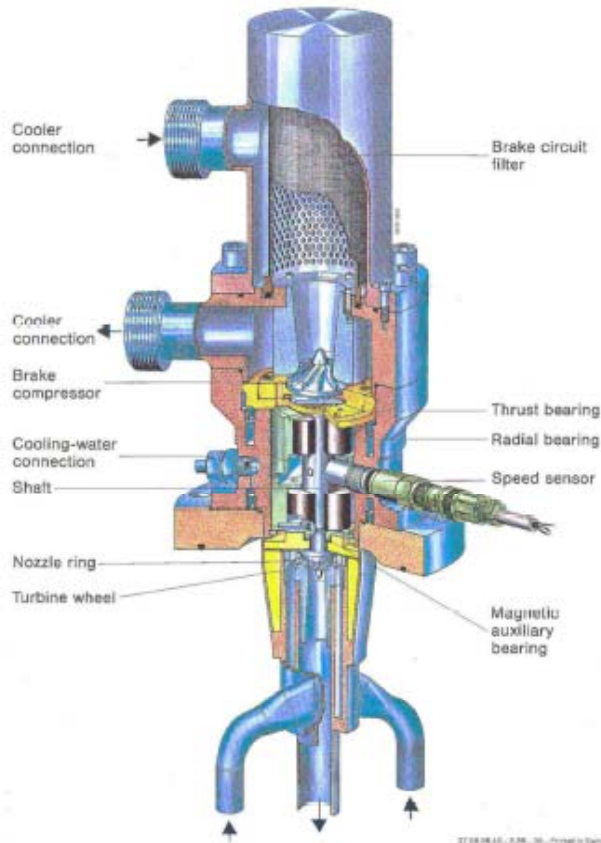

Cryogenic turboexpander
Self-acting gas bearing system

Figure 8.2.2b: Dynamic gas bearing turbine
(Courtesy of CPS, Linde BOC Process Plants)



Operated by the Jefferson Science Associates for the U.S. Dept. of Energy



Typical Helium Cryogenic System and its Basic Components (Cont.)

Expander – Types

- **Turbo-expanders**
 - **Dynamic gas bearing turbines are inherently more efficient since they do not use an external gas supply for the bearing**
 - **Normally used for pressure ratios < 5**
 - **Tend to be vulnerable to large, sudden system load transients**
 - **Static gas bearing turbine systems are inherently less efficient than the dynamic gas bearing turbines since they use external bearing gas that requires additional compressor capacity and will leak into the process**
 - **Normally used for higher pressure ratios**
 - **Tend to be less vulnerable to system load transients since the bearing capacity is dependent on the externally supplied gas**
 - **Oil bearings are normally used for larger turbine sizes and require a separate oil supply loop for the bearings**
 - **Oil skid increases the capital cost**
 - **Additionally, if the oil seals fail, oil can leak into the cold box**



Typical Helium Cryogenic System and its Basic Components (Cont.)

Observed Turbine Efficiencies in Helium Service

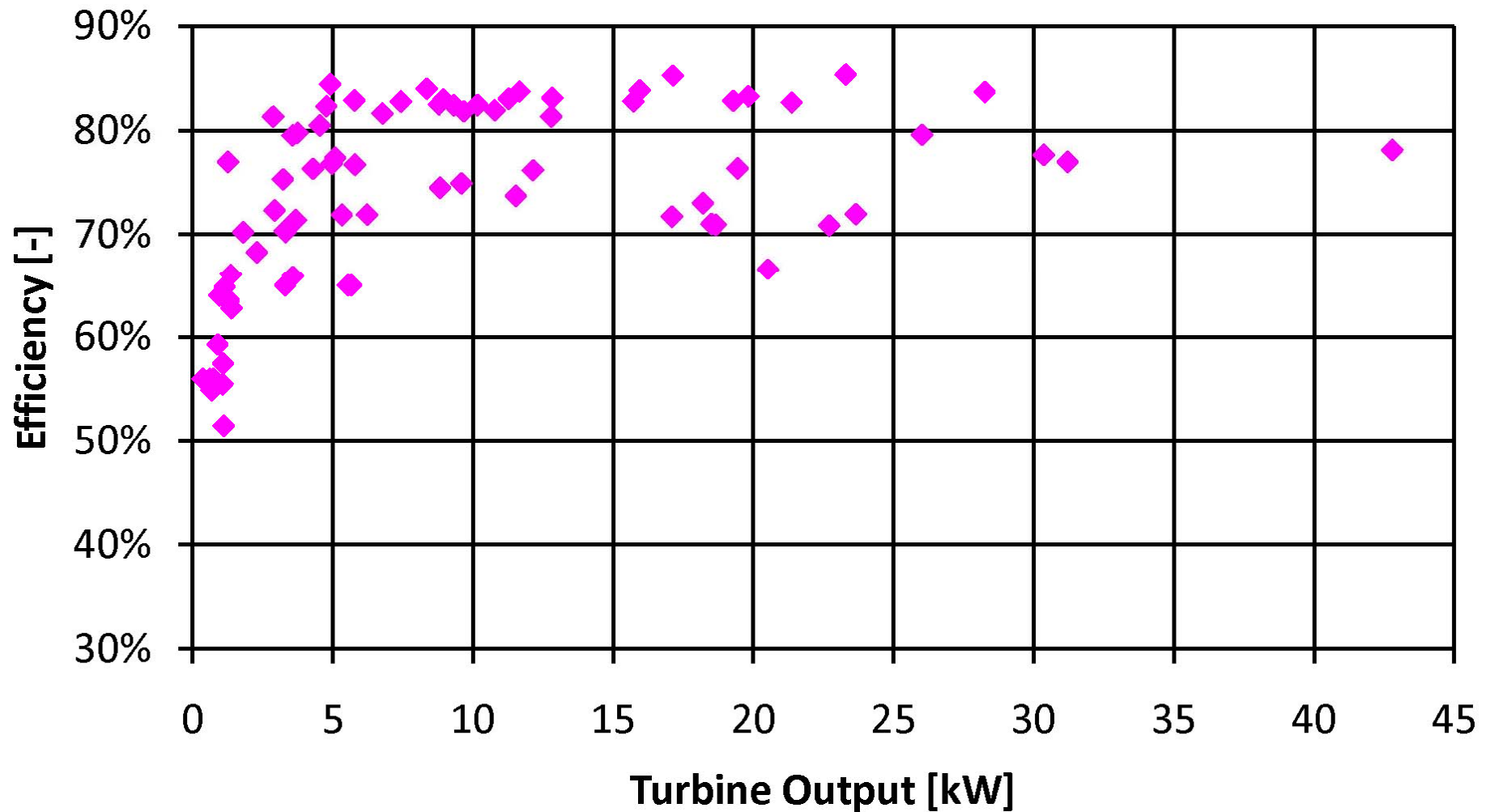

Operated by the Jefferson Science Associates for the U.S. Dept. of Energy



Typical Helium Cryogenic System and its Basic Components (Cont.)

Cold Box - 80K & 20K Carbon Beds & Valves

- Adsorber beds are located at the 80K and 20K level
 - Used to remove contamination and residual gases (Nitrogen, Oxygen, Hydrogen, etc) from the helium flow
 - Keep a clean process flow to expanders and HX's
- Dual carbon beds at 80K and at least a single carbon bed at 20K are highly recommended to keep the circulating helium clean
- Normal design goal for the 80K beds:
 - Clean up to 10 ppm (by volume) of nitrogen from the total design flow down to less than 1 ppm (by volume)
- One of the main factors detracting from the operation of these beds is the ability to properly isolate them from the process
 - In practice isolation valves often leak making it impossible to regenerate the beds
 - Providing thermal stabilization loops for these valves eliminates this problem; e.g., BNL purifier designed in the 1980's still operating without a valve leak problem
 - All cryogenic valves should be installed with thermal loops that allow the valve to reach equilibrium temperature on both sides of isolation.
 - They also reduce the piping stress, thus aiding valve sealing in repeated use



Typical Helium Cryogenic System and its Basic Components (Cont.)

Cold Box – Phase Separators & Load Test Heaters

- Many cold boxes normally have two phase separators
 - One for LN₂ and other for LHe.
- Should be sized for the required volume at a 50% level control
- Recommended volume for LN₂ phase separator is a minimum of 15 minutes of operating capacity at 50% level
- Recommended design criteria for proper gravity phase separation at ~ 1 atm operating condition for the liquid-vapor interface cross-sectional area, limit,
 - Nitrogen vapor velocity < 20 cm/s
 - Helium vapor velocity < 5 cm/s

Note: Sometimes they are built with horizontal pipes to achieve this separation area in smaller volumes.
- Helium phase separator should be equipped with a heater
 - Limit the heat flux at the heater surface to < 1.0 W/cm²)
 - Heater should be sized for testing the system in the refrigeration mode
- If required, additional heaters should be included in the cold box for shield load test and handling the transient loads.



Typical Helium Cryogenic System and its Basic Components (Cont.)

Auxiliary Cold Boxes

- **Auxiliary cold boxes are typically used for housing cold compressor systems and/or circulating pumps**
- **Cold Compressors**
 - **Cold compressors are used to maintain the sub-atmospheric pressure required at the load for low temperature operations; i.e., $< 4.3\text{K}$**
 - **Both low capacity reciprocating and high capacity centrifugal compressors are commercially available for this application**
 - **Cold compressor systems, including the HX's, valves and instrumentation are housed in a vacuum insulated cold box.**
 - **They are generally shielded using LN_2 to intercept the thermal radiation load on the system components**



Typical Helium Cryogenic System and its Basic Components (Cont.)



SNS 2-K Cold Box



Operated by the Jefferson Science Associates for the U.S. Dept. of Energy



Typical Helium Cryogenic System and its Basic Components (Cont.)

Auxiliary Cold Boxes

- **LHe Make-up and Circulation Pumps**
 - The need for liquid helium pumps has been envisioned in many projects, but they have been slowly eliminated by improved process designs
 - Today we need to think very carefully before including a LHe pump in the process requirement; often there are more efficient, more reliable and less expensive process options available to accomplish the same task
 - Where required, both reciprocating (low capacity) and centrifugal pumps (for higher capacity) are commercially available
 - Makeup pumps are generally designed for a higher-pressure differential than the circulating pumps
 - All of these pumps are also housed in vacuum insulated cold boxes similar to those used for cold compressors



Typical Helium Cryogenic System and its Basic Components (Cont.)

Liquid Helium Storage

- The liquid storage specification requires careful evaluation
- Stable helium system operation is often not possible without a LHe dewar
- Presently the LHe storage dewars (1000 to 30,000 gallon) cost in the range of \$5 to \$8 per liter, while warm helium storage costs 3 to 4 times that much.
- Total cost will be much higher for either storage method once it is integrated into the remainder of the system
- Main questions to address are the size and the expected process function to be supported by these dewars



Operated by the Jefferson Science Associates for the U.S. Dept. of Energy



Typical Helium Cryogenic System and its Basic Components (Cont.)



Figure: 8.4.1 7000 liter LHe dewar at SNS



Operated by the Jefferson Science Associates for the U.S. Dept. of Energy



Typical Helium Cryogenic System and its Basic Components (Cont.)

Liquid Helium Storage

- **Disadvantages of large dewars are:**
 - Capital cost
 - Hard to keep track of helium losses
- **Disadvantages of small dewars are:**
 - Need to provide large warm storage
 - so, it costs more for a given inventory
 - May not provide enough capacity to average out the peak to average loads of the system capacity
 - so, it takes a longer time to recover the system and loads after a trip or a shut down
- **Some of the design considerations required are:**
 - size of the dewar
 - heat leak
 - LN₂ shield or helium vapor shield
 - interface connections (e.g., dewar neck size) required



Typical Helium Cryogenic System and its Basic Components (Cont.)

Liquid Helium Storage

- **LHe dewar system should be provided with:**
 - **Helium supply from cold box**
 - **Vapor return line(s) to cold box and other systems like an ambient vaporizer**
 - **Liquid withdrawal line**
 - **External fill line**
 - **Heater**
 - **Sub-cooler**
 - **this is recommended, since it utilizes the refrigeration capacity efficiently for peak loads**
 - **Instrumentation (pressure, liquid level, etc.)**



Typical Helium Cryogenic System and its Basic Components (Cont.)

Gaseous Helium Storage

- **High pressure gas storage tubes (3000 psig)**
 - **High-pressure storage tubes are used for transportation and sometimes as on site inventory management**
 - **charging requires a very high-pressure compressor**
 - **Economical for transportation and can serve where limited storage space precludes the more common 250-psig storage tanks**



Operated by the Jefferson Science Associates for the U.S. Dept. of Energy



Typical Helium Cryogenic System and its Basic Components (Cont.)



30,000 gal., 250 psig Gaseous Helium Storage Tanks at SNS



Operated by the Jefferson Science Associates for the U.S. Dept. of Energy



Typical Helium Cryogenic System and its Basic Components (Cont.)

Gaseous Helium Storage

- **High pressure gas storage tanks (250 psig)**
 - **A helium gas storage capacity rated for 18 atm (i.e., 250 psig) is normally required to operate a helium refrigeration system**
 - **Size of the tanks depends on the economic analysis of the,**
 - **total helium inventory storage required and the,**
 - **cold and warm storage allocation**
 - **The presently accepted standard for a warm gas storage unit (i.e., tank) has a,**
 - **pressure rating of 250 psig (18 atm)**
 - **capacity of 30,000 gallons**
 - **design in accordance with CGA Standard 341 to withstand a full vacuum (for evacuation during commissioning)**



Typical Helium Cryogenic System and its Basic Components (Cont.)

Cryogenic Distribution Systems

- **Distribution Boxes**
 - The distribution box is the interface between the refrigerator cold box, LHe storage dewar and liquid nitrogen supply to the load transfer-line piping
 - It normally contains sub-coolers with HX's, heaters, piping, control valves and instrumentation
 - There should be connections provided in this distribution/interface box for cool-down and warm-up of the loads if required



Operated by the Jefferson Science Associates for the U.S. Dept. of Energy



Typical Helium Cryogenic System and its Basic Components (Cont.)

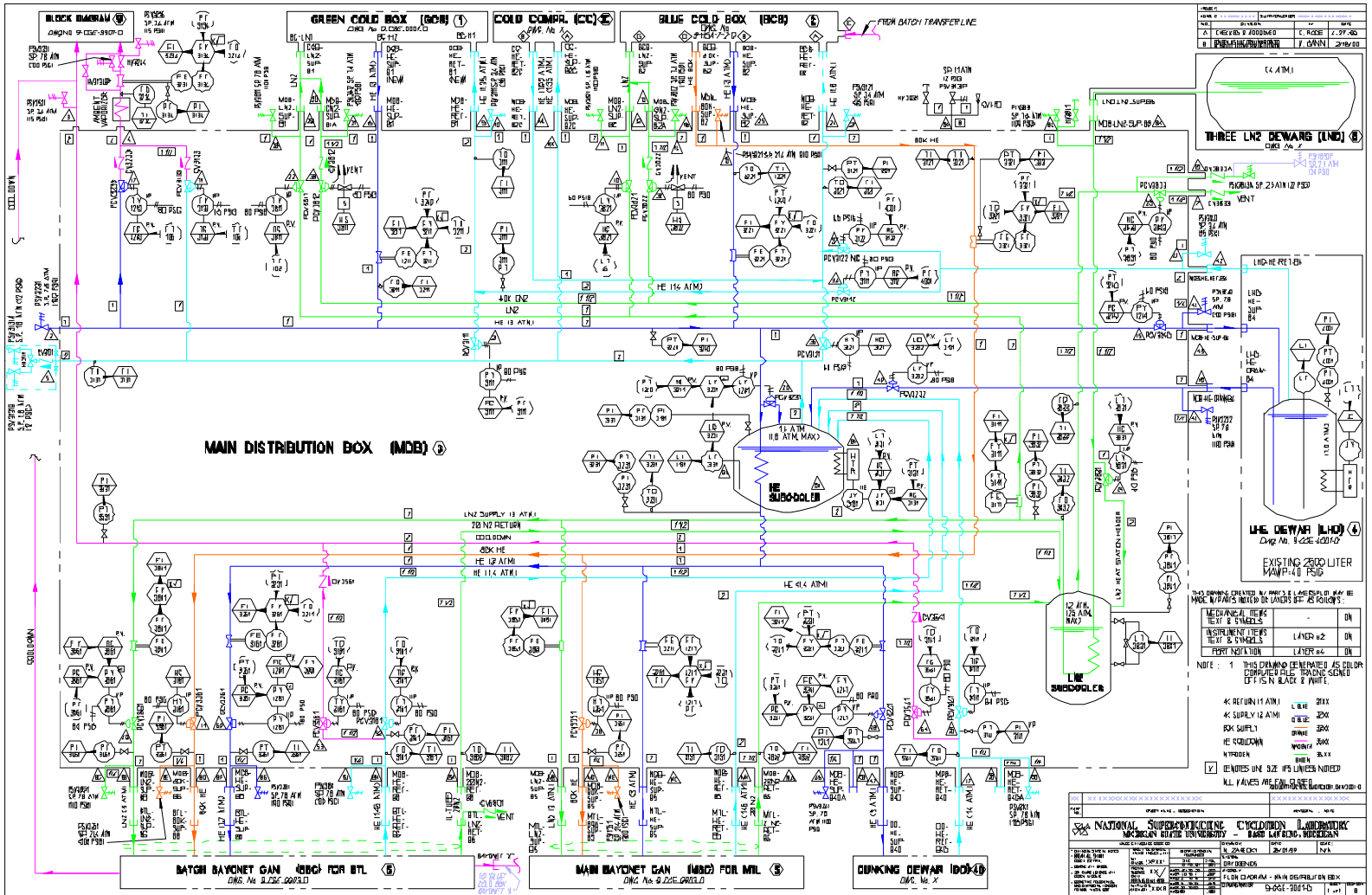

Figure 8.6.1 Distribution Box [at MSU]



Operated by the Jefferson Science Associates for the U.S. Dept. of Energy



Typical Helium Cryogenic System and its Basic Components (Cont.)

Cryogenic Distribution Systems

- **Transfer-lines**
 - **Vacuum insulated (jacketed) lines between the equipment and the loads are widely used for the transfer of cryogen flows**
 - **Design considerations are pressure drop (line size), heat leak, LN₂ or other helium shield(s) and vacuum maintenance**
 - **The number of connections (bayonets) between these lines and the load are a major source of the heat leak and should be minimized to reduce the system load**
 - **Future capacity needs should be considered in the sizing of these lines since size constraint can become an upgrade bottleneck**
 - **A useful design guideline for pressure drop is in the range of 2% (nominal) to 5% (maximum) of the operating pressure of that line**



Typical Helium Cryogenic System and its Basic Components (Cont.)

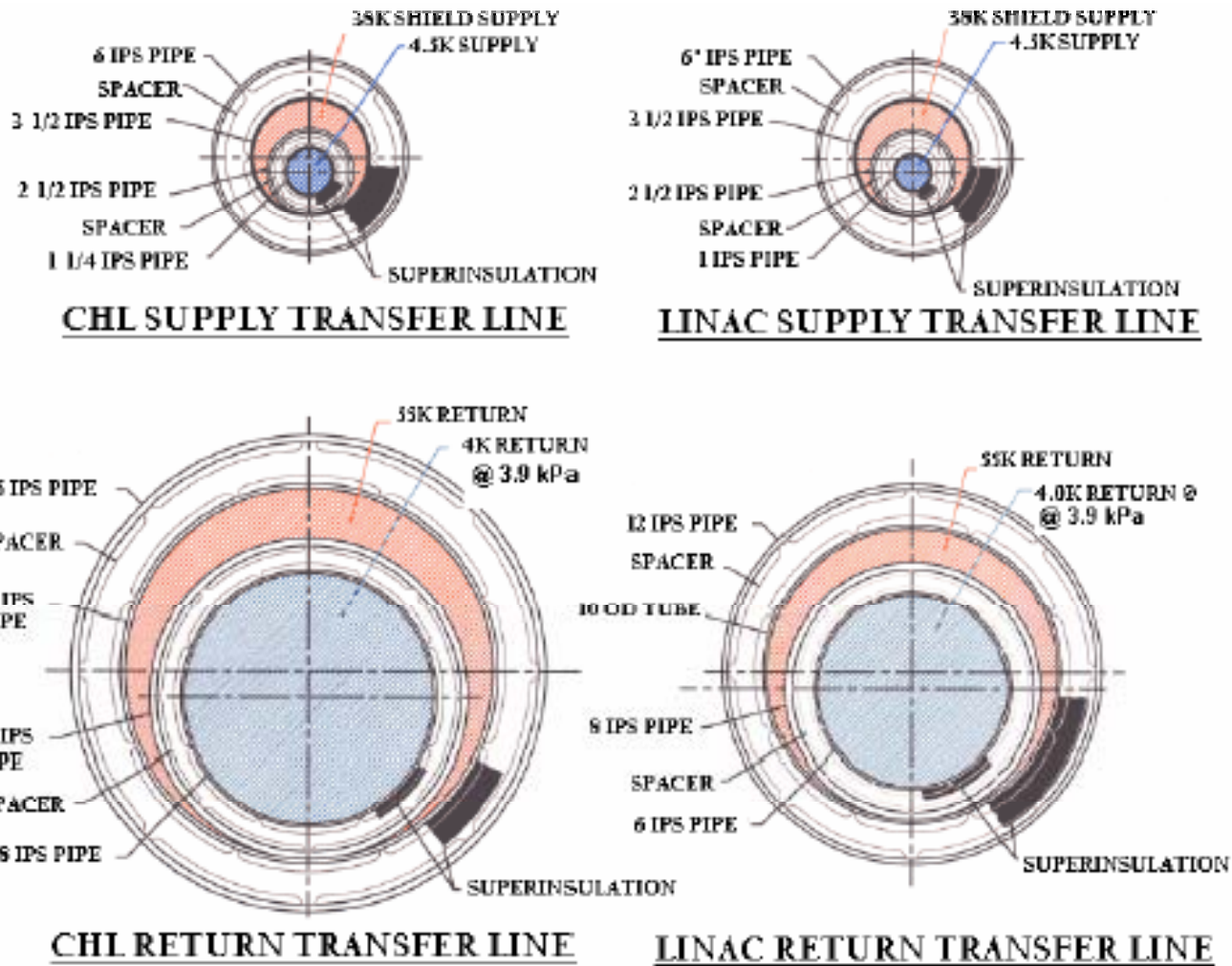

Figure 8.6.2 Cross sections of various transfer lines used at SNS



Typical Helium Cryogenic System and its Basic Components (Cont.)

Nitrogen System

- **Liquid nitrogen storage dewars and LN₂ distribution**
 - **LN₂ dewar size requirement should to be based on the LN₂ demand, delivery schedule and capacity details of the site location**
 - **If the refrigeration system is designed with LN₂ pre-cooling it will be a main load on the LN₂ system**
 - **Dewar sizing should consider local weather constraints and summer LN₂ plant power restrictions (i.e., availability)**
 - **The standard-size 20,000 gallon liquid nitrogen dewar is widely used for the LN₂ storage**
 - **These dewars are normally equipped with bottom and top fill valves fed from a standard CGA fill connection**



Typical Helium Cryogenic System and its Basic Components (Cont.)

Nitrogen System

- **GN₂ generation and distribution**
 - **Gaseous nitrogen system (GN₂) is commonly provided for utility purposes and consists of an ambient vaporizer for GN₂ generation and interconnecting piping**
 - **GN₂ is commonly used for back-filling cold boxes and transfer-lines to prevent moisture in the super-insulation during open-to-air maintenance periods of the system**
 - **It is also used for initial process piping cleanup and initial regeneration of the system carbon beds**



Operated by the Jefferson Science Associates for the U.S. Dept. of Energy



Typical Helium Cryogenic System and its Basic Components (Cont.)

Auxiliary Equipment

- Purifier system
 - A dual bed charcoal purifier to purify the system equipment at commissioning and to purify the helium makeup gas to be added the system is highly recommended
 - Normal design goal: with stream impurities up to 100 ppmv (by volume) of nitrogen (and 30 ppmv oxygen), reduce to less than 1 ppmv at bed design flow
 - Purifier bed life should be a minimum of 1 month for the impurity level specified and the regeneration time less than two days
 - Design of the purifier 80K bed is similar to those used in the 4.5-K main cold box
 - Upstream dryer beds are designed using a descant, that if not properly regenerated will allow moisture to reach the purifier HX and create an increased pressure drop



Typical Helium Cryogenic System and its Basic Components (Cont.)

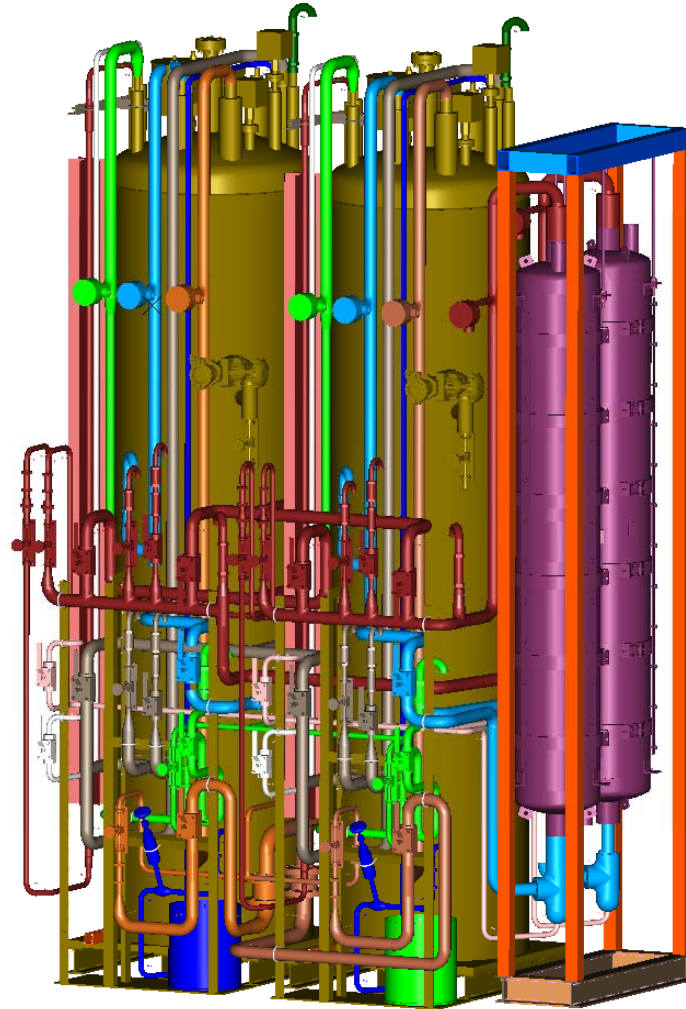

JLab Helium Purifier System



Operated by the Jefferson Science Associates for the U.S. Dept. of Energy



Office of Science
U.S. Department of Energy

Typical Helium Cryogenic System and its Basic Components (Cont.)

Auxiliary Equipment

- **Instrument air system**
 - Instrument air systems normally consist of a dual air compressor system, with each compressor sized for a system service factor of 1.5
 - They normally include air storage, filters, pressure swing cleanup cycle for air dehydration, pressure regulators and interconnecting piping
 - Air supply system should be organized so that all use points of a subsystem are grouped and supplied together
 - Good practice suggests that local surge volume isolation valves be installed for each sub-group and individual user (i.e., valve operator)



Typical Helium Cryogenic System and its Basic Components (Cont.)

Utilities

- **Electric power supply**
 - **Electrical power supply for large cryogenic equipment facilities can not be taken for granted**
 - **Cryogenic plants require a long time and a lot of effort to restart and reach stable operating points; much of the load equipment can be costly and fragile and allow only a limited number of controlled thermal cycles**
 - **Given these facts, the power supply system needs to be well designed and engineered to be as robust as possible to reduce problem downtime and to support the highest flexibility**
 - **To maximize online time, thought should be given to redundant independent power feeds and to redundant independent primary sub-stations**
 - **This arrangement allows either the feeder or substation to be off-line for repair or maintenance without forcing the entire electrical system to be down**



Typical Helium Cryogenic System and its Basic Components (Cont.)

Utilities

- **Cooling Water System**

- Typically, the heat sink for a helium refrigeration plant is constant temperature water system that rejects heat to the environment in an evaporative cooling tower
- The refrigeration plant heat sink must be very reliable through extreme variations in atmospheric temperature and humidity
- Water-cooled components of the refrigeration plant include:
 - Main process compressors (the dominant loads)
 - Expander brake HX
 - Process vacuum pump (if any)
 - Any auxiliary pumps or compressors, including insulating vacuum or 'guard vacuum' pumps
- Cooling water system, simplicity, efficiency and reliability are paramount; ***the reliability and capacity of the best helium refrigeration system is limited by the reliability and capacity of the heat sink; i.e., the cooling water system!***

