

NPS Base Frame

Slides from Mike Fowler

- Welded construction
- Rails from SOS detector
- 3 meters adjustment

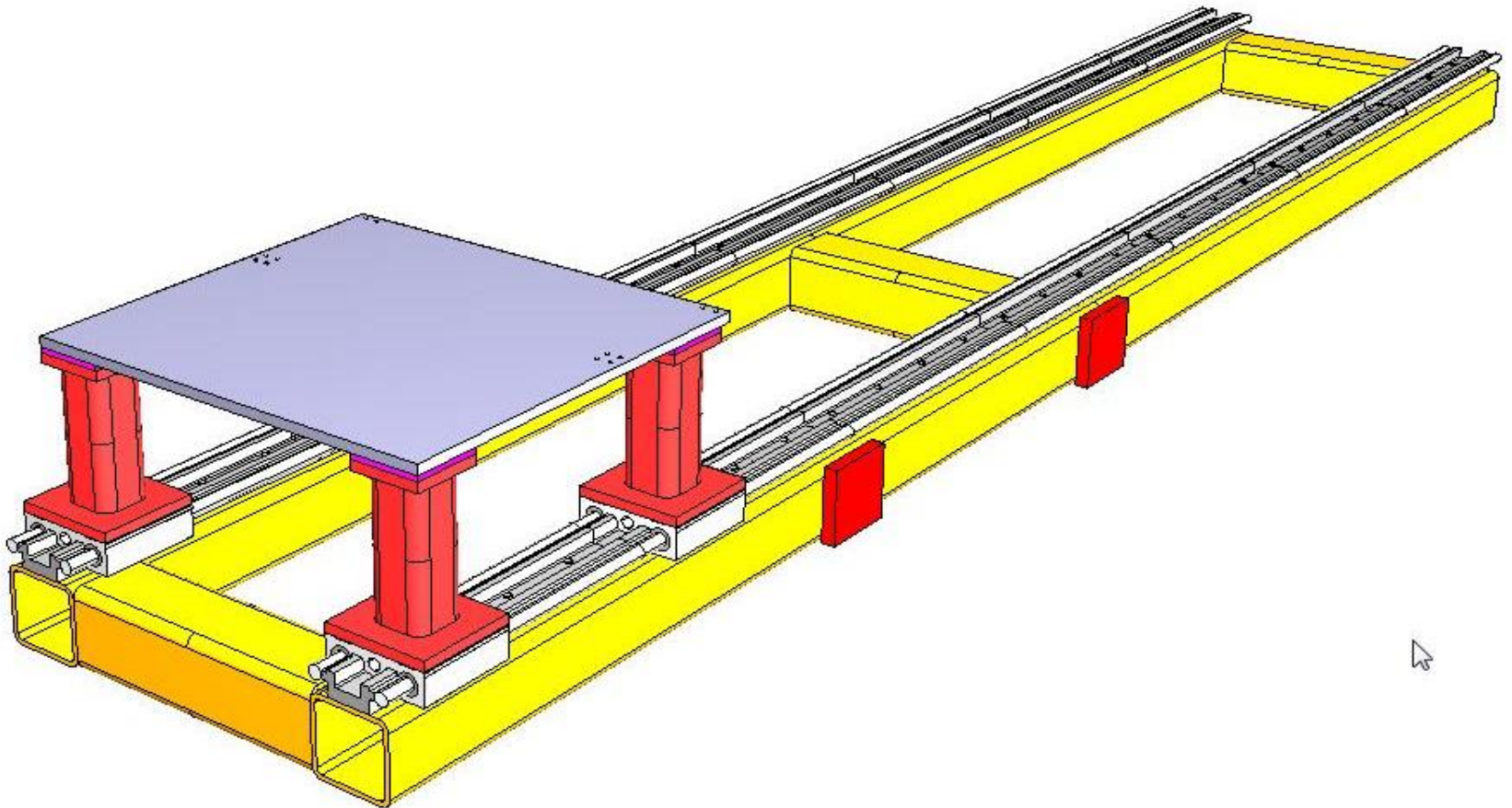

NPS Detector

Ease of assembly on base
frame

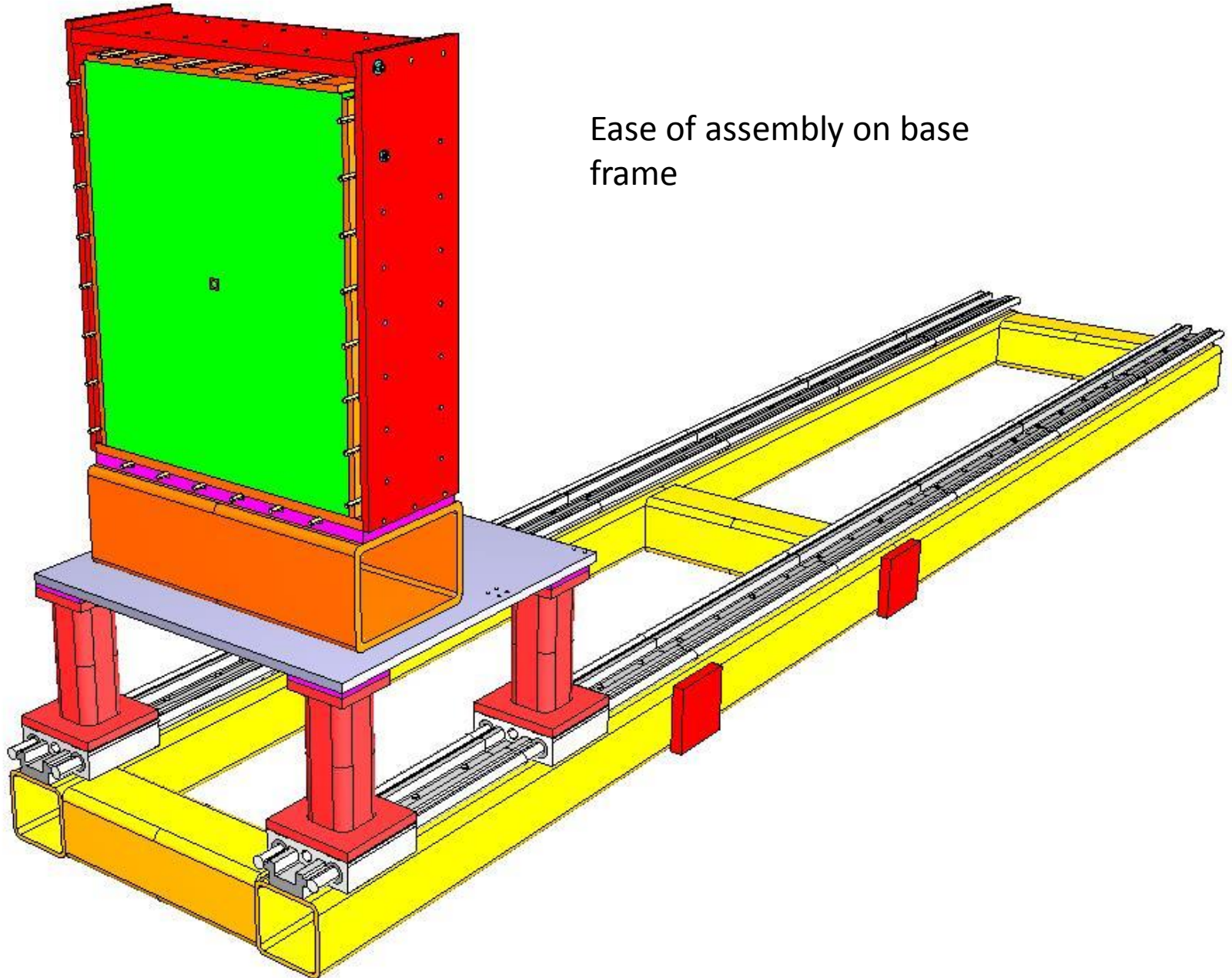

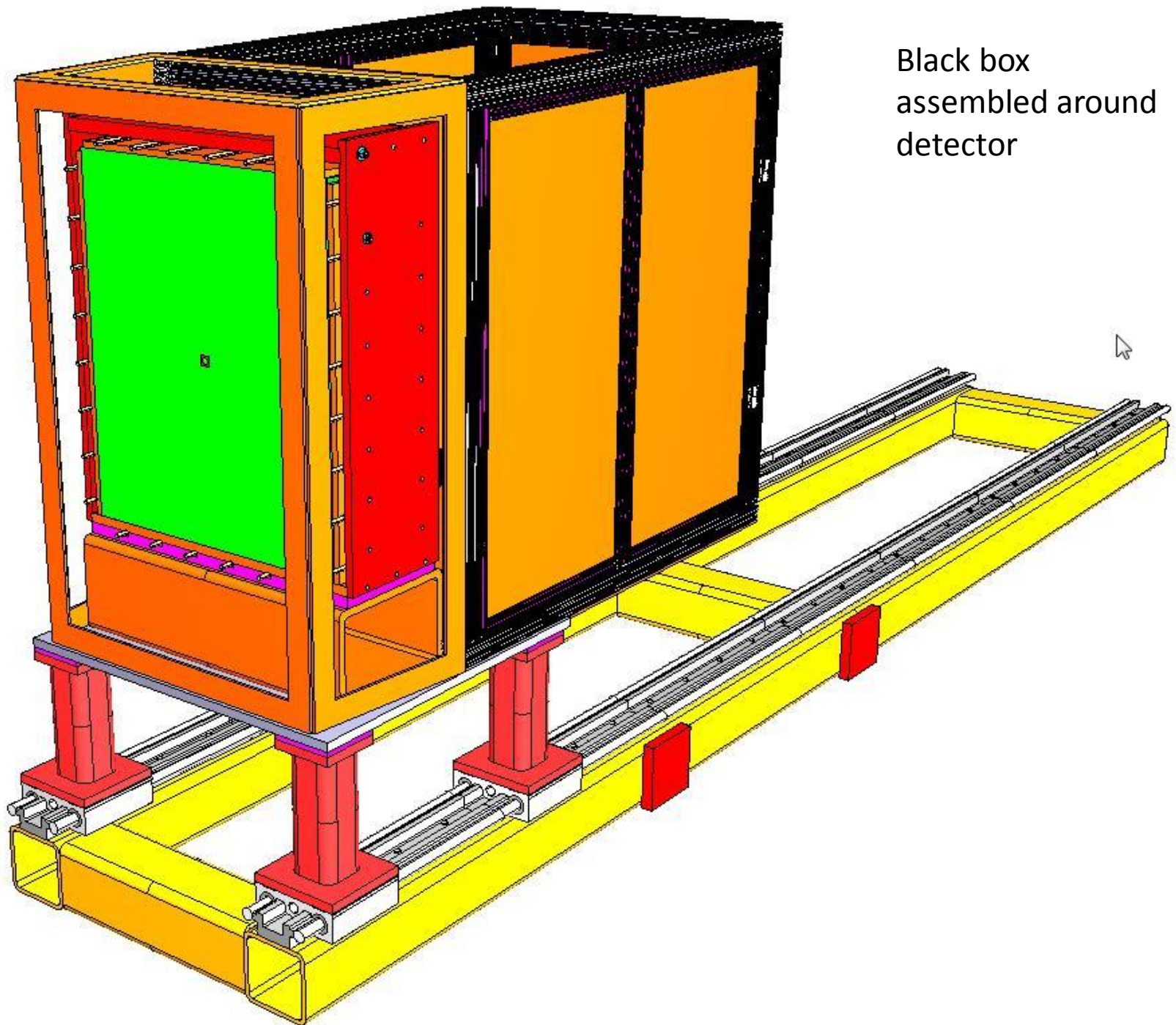

Black box
assembled around
detector

Double hinged doors
with lift off hinges.

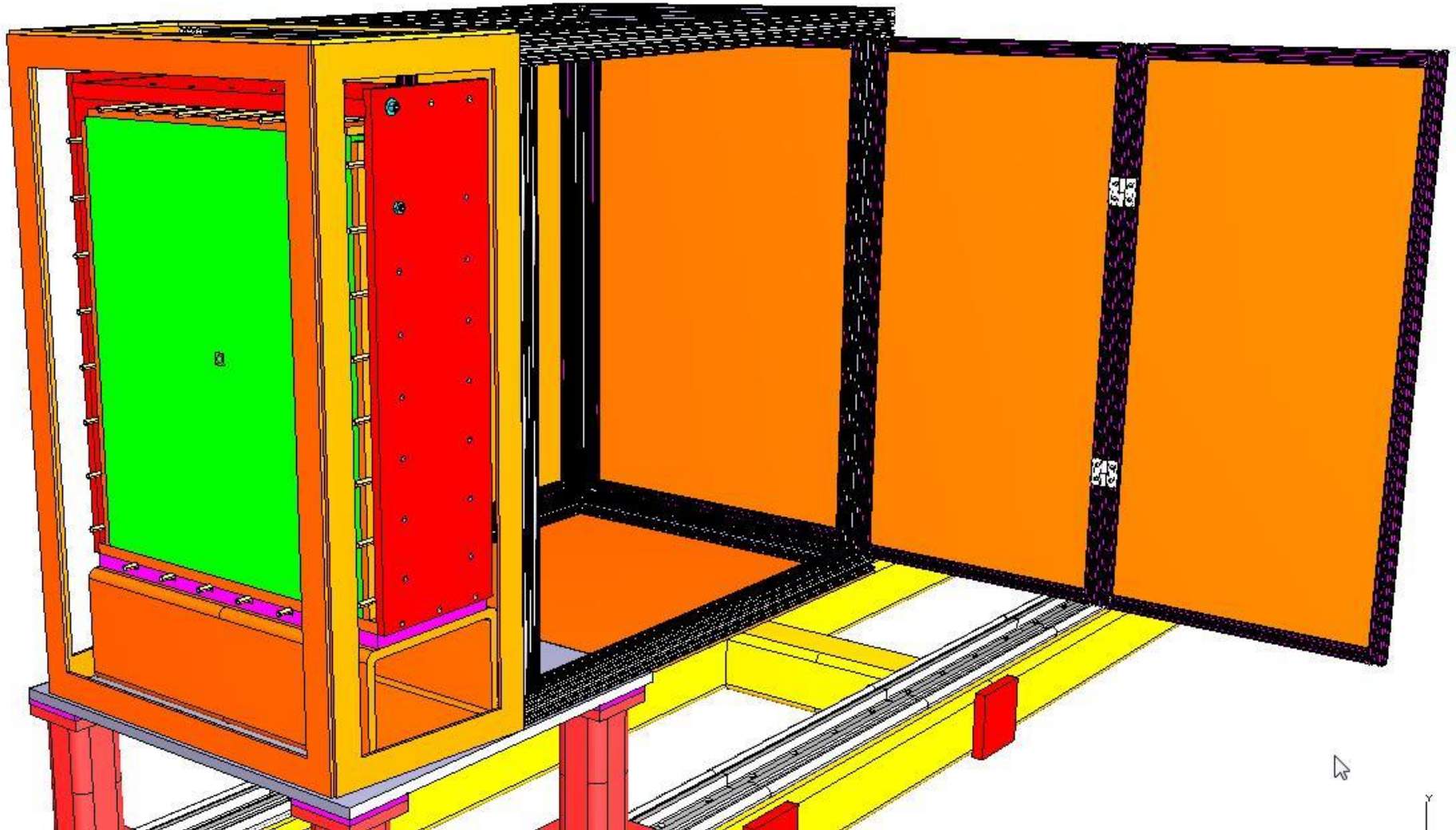

1/5" clearance to beam pipe
@ 6 deg.

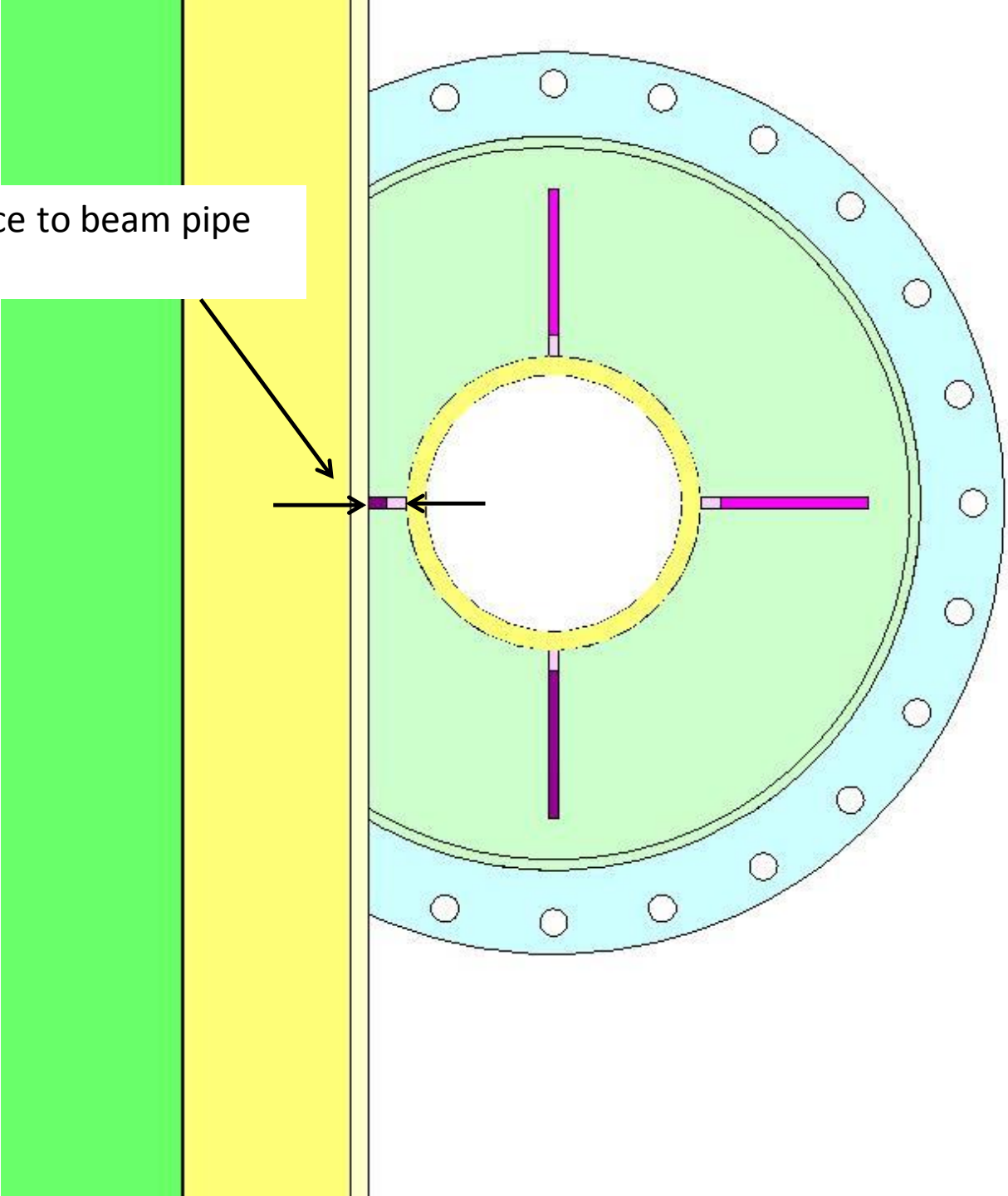

Near term projects

- a) Adding in the cooling, cabling, etc. – plan is to have this done by the end of the year
- b) The cantelevered platform off SHMS – 2018 project
- c) 3D overview drawing with NPS magnet, detector etc, with the spectrometers. – can in principle be done anytime, but for real fabrication drawings need to wait until detector is near completion