



HPS Overview

S. Stepanyan (JLAB)

HPS Upgrade ERR

June 12, 2017, Jefferson Lab

Outline

- Introduction
- HPS performance during 2015 and 2016 engineering runs
- Status of data analysis
- Why upgrades (#1)
- HPS setup for 2018 run (#1, #2)
- Beamline with CLAS12 (#2)
- Expected radiation levels (5)
- Documentation (#6)
- Summary

Cosmological Evidences for Dark Matter

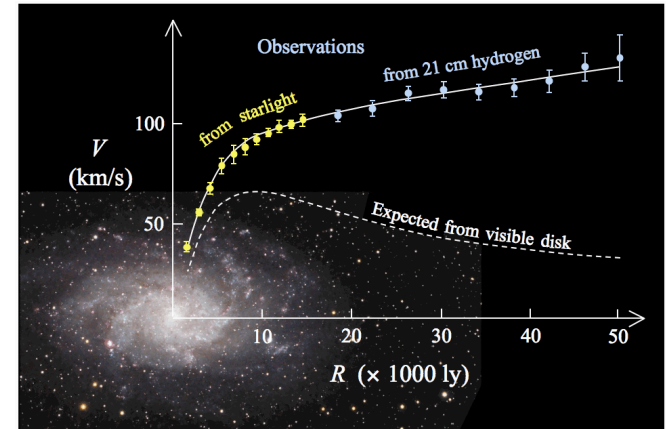
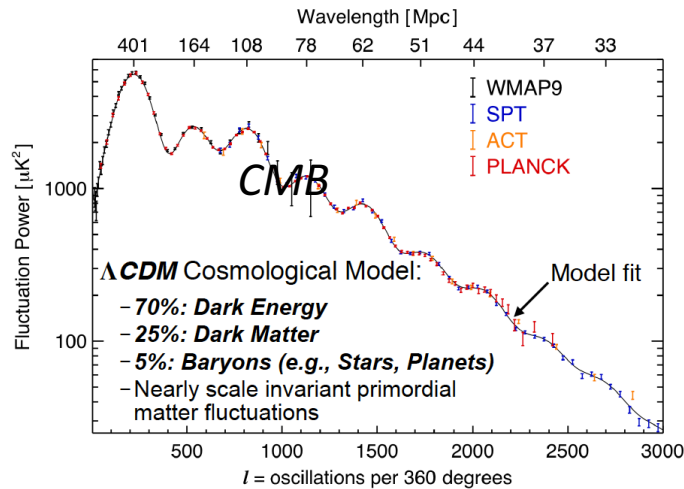

All observations can [only] be explained in a coherent manner if the gravitational effect of a huge amount of non-baryonic matter [dark matter (DM)] is assumed

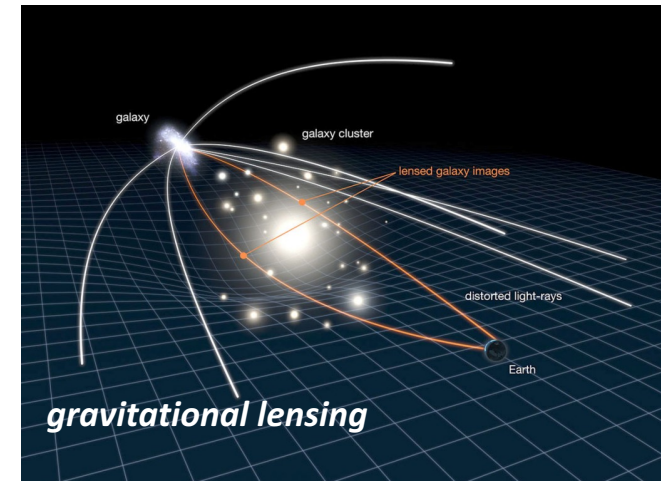
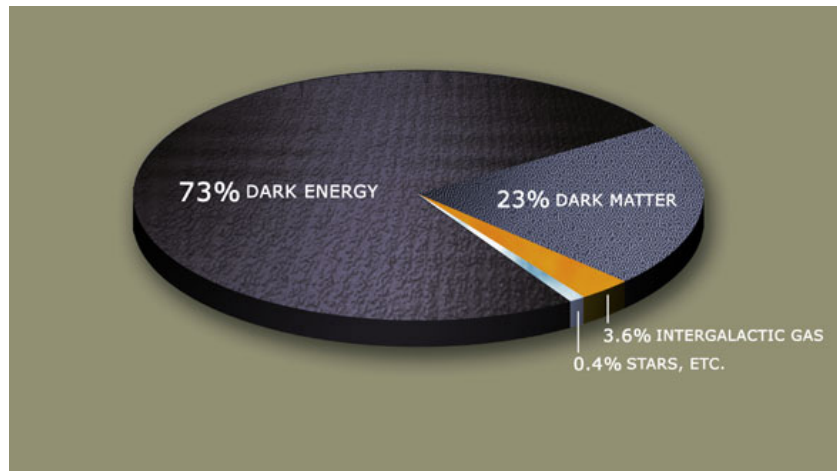

The Vector Portal to Hidden Sector

The simplest case, a heavy particle that is charged under both EM and DM charges, and couples to the Standard Model photon through the kinetic mixing.

B. Holdom, Phys. Lett. B 166, 196 (1986).

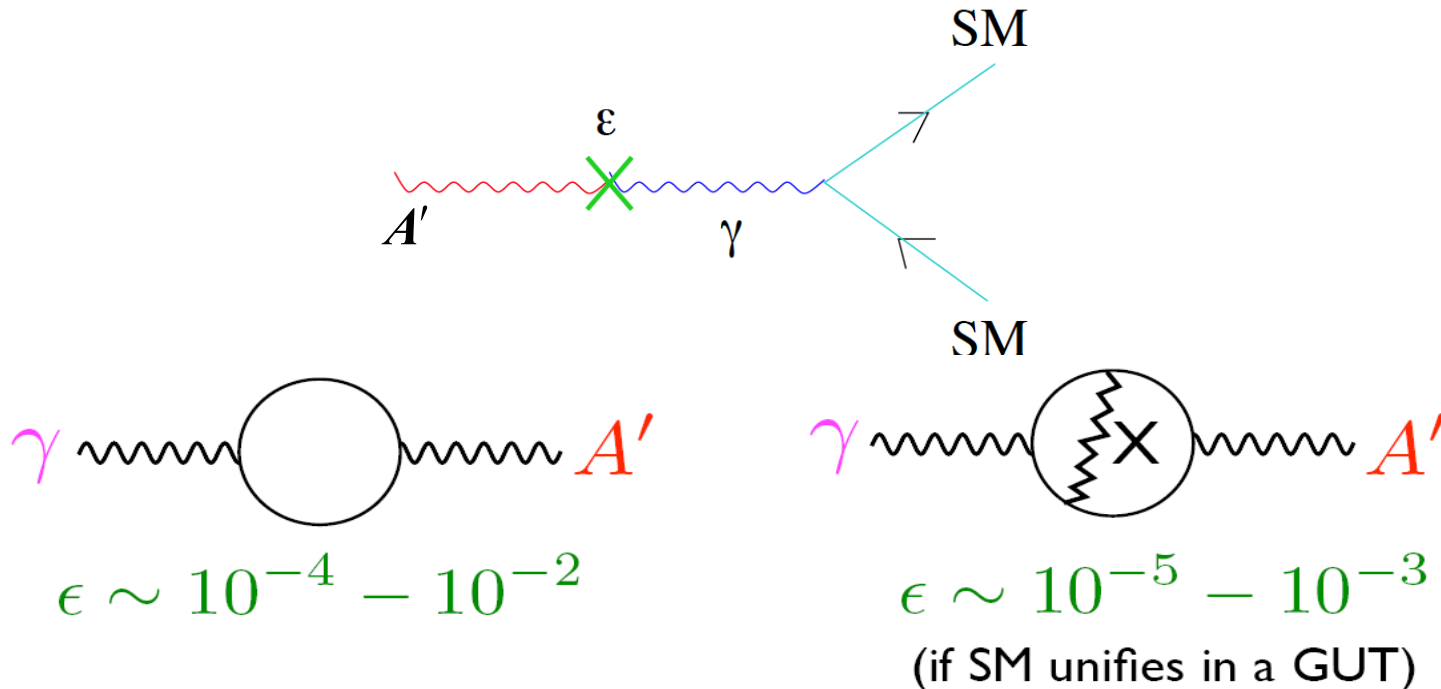

$$\epsilon^2 = \frac{\alpha'}{\alpha} \quad \alpha \text{ is the fine-structure constant}$$

Fixed target experiments: kinematics

$$\frac{d\sigma}{dx} \propto \frac{\alpha^3}{\pi} \frac{\epsilon^2}{m_e^2 \cdot x + m_A^2 (1-x)/x}$$

$$x = \frac{E_A}{E}$$

Kinematics **very different** from massless photon bremsstrahlung

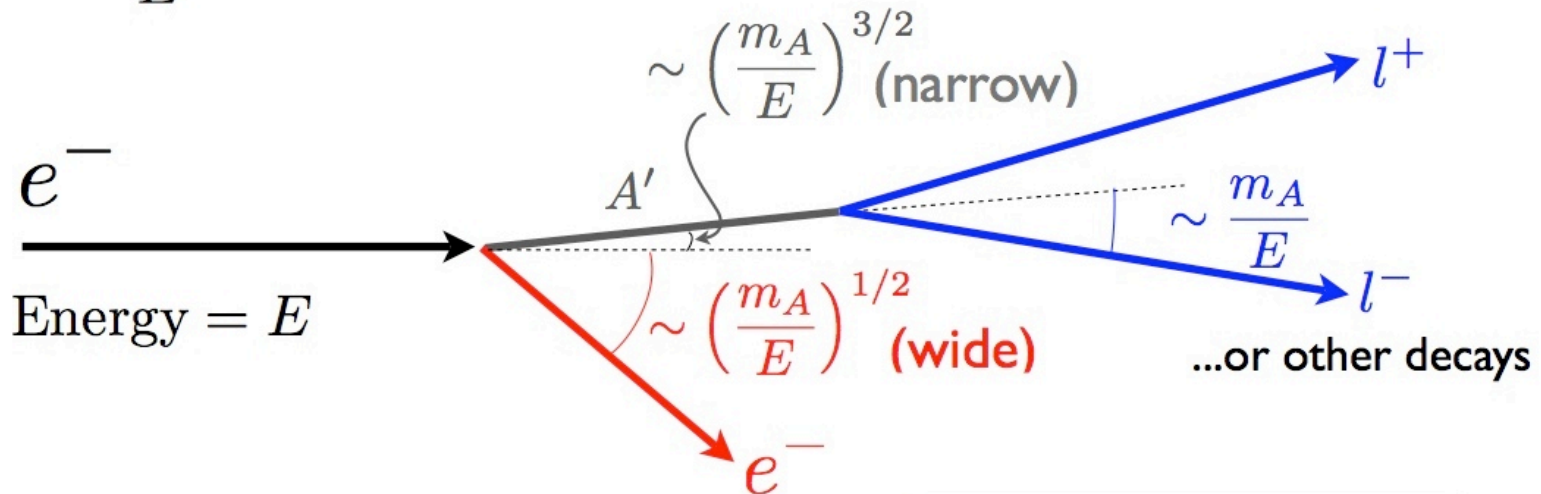

Heavier product (here A')
takes most of beam energy

$$E_A \sim E - m_A$$

$$E_e \sim m_A$$

J.D. Bjorken, R. Essig, P. Schuster, and N. Toro, Phys. Rev. **D80**, 2009, 075018

HPS in Hall B

PbWO₄ Ecal Installed September, 2014

Si Vertex Tracker Installed Feb 23, 2015

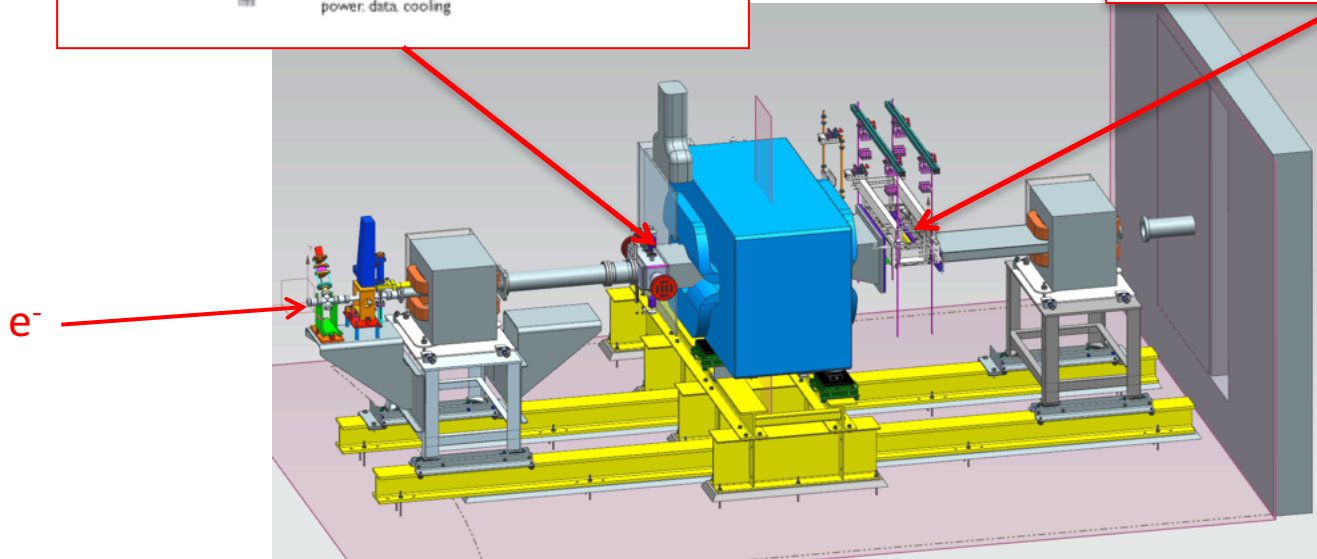
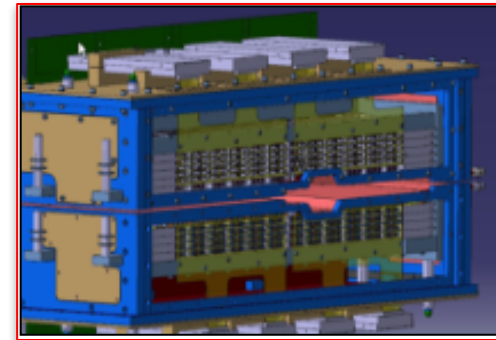
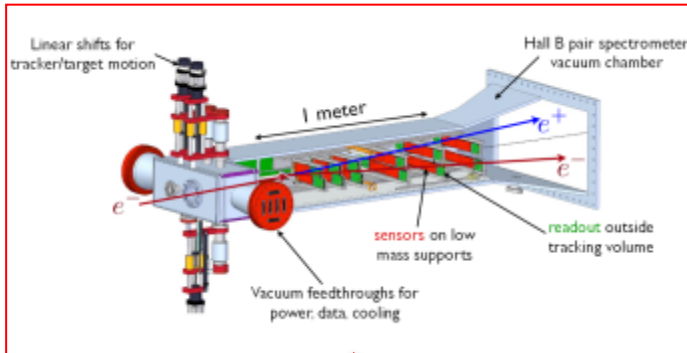

A magnet chicane directs the CEBAF electron beam onto a W foil. Produced e^+e^- pairs are triggered by PbWO₄ Ecal and momentum analyzed by the Si vertex tracker inside the analyzing magnet.

HPS Experiment

Bump hunt region

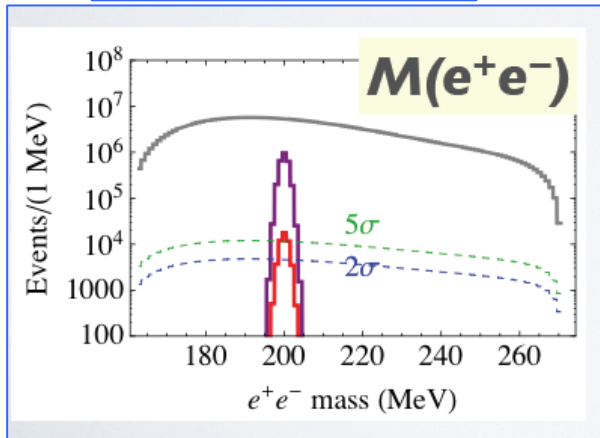

Displaced decay vertex search

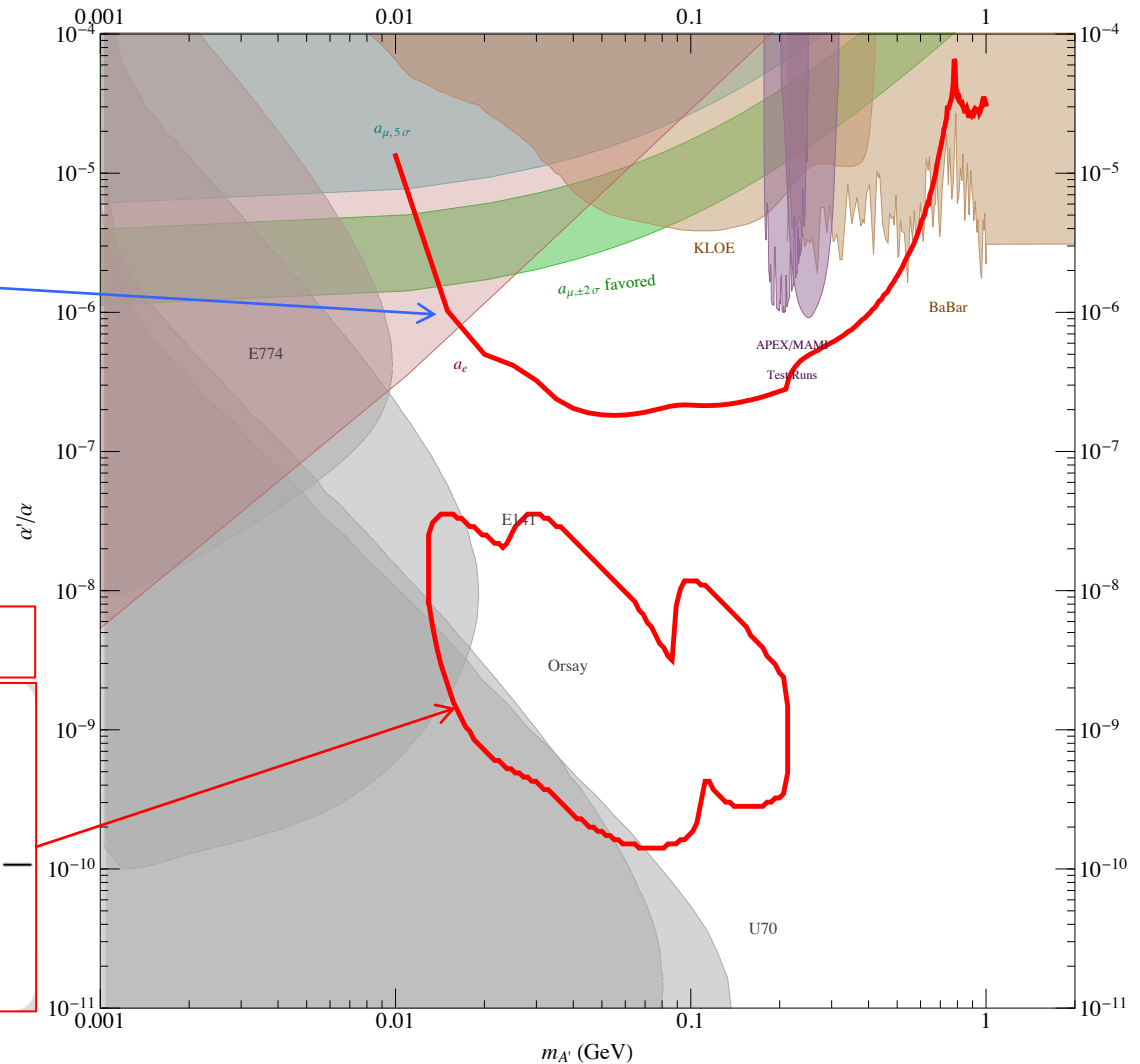
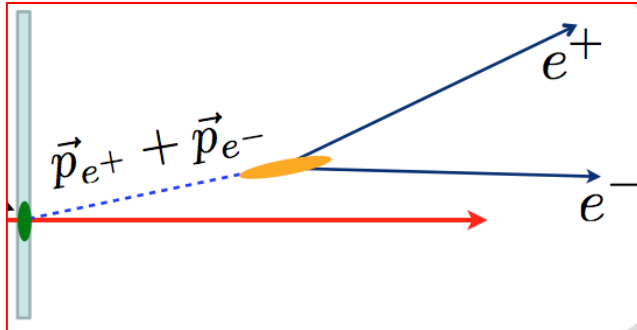

HPS Engineering runs, spring 2015 and 2016

**Beam's Eye View of the SVT
inside the vacuum chamber**

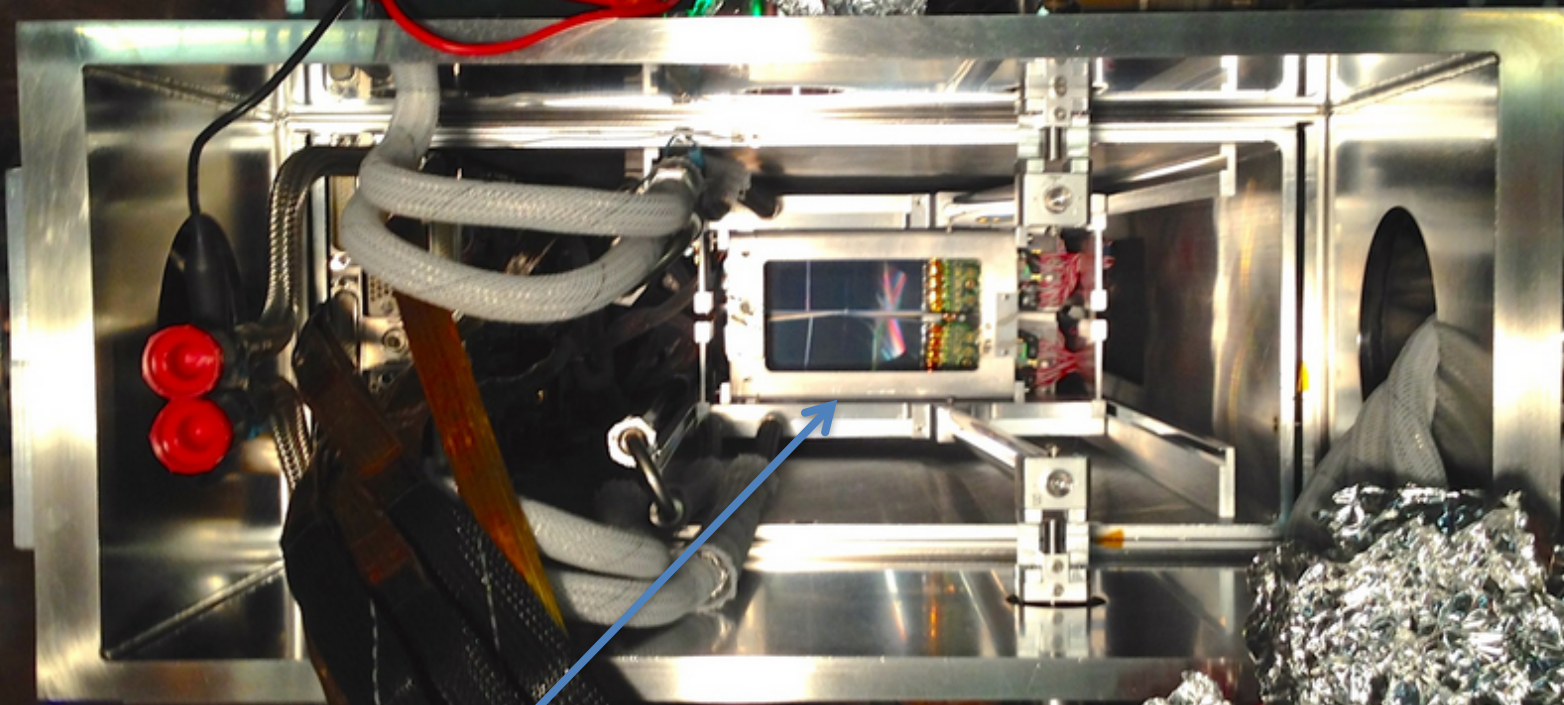

**Si Layer I is only 10 cm from W target and has only
1 mm gap between top and bottom modules for
 $\sim 10^{12}$ /sec electrons go through**

HPS Engineering Runs

Two successful runs:

- Spring 2015: 50 nA, 1.056 GeV electron beam (night and weekend running)
 - SVT in two configurations, edge at 1.5 mm and 0.5 mm
 - 10 mC accumulated charge at each SVT position (1.7 PAC days)
- Spring 2016: 200 nA, 2.3 GeV electron beam (weekend running)
 - 92.5 mC accumulated charge with SVT at 0.5 mm (5.4 PAC days)

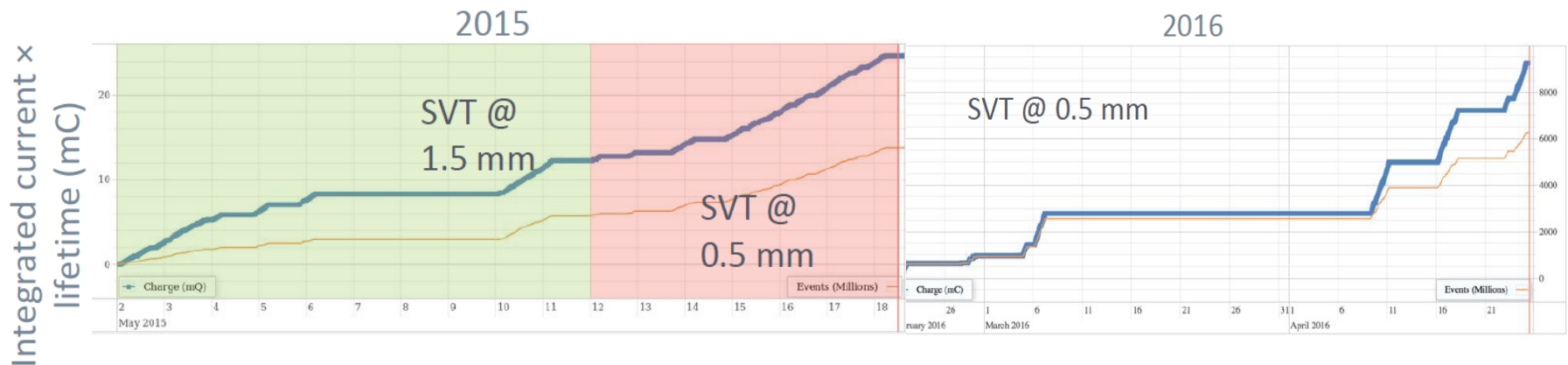

Beamline Performance

- High quality beam was delivered with the vertical beam size of $14\ \mu\text{m}$
- The beam halo was as small as 10^{-5}
- The vertical beam position was maintained within $20\ \mu\text{m}$ throughout the run by the beam feedback system
- **No changes in the beam control or monitoring is expected for the next run**

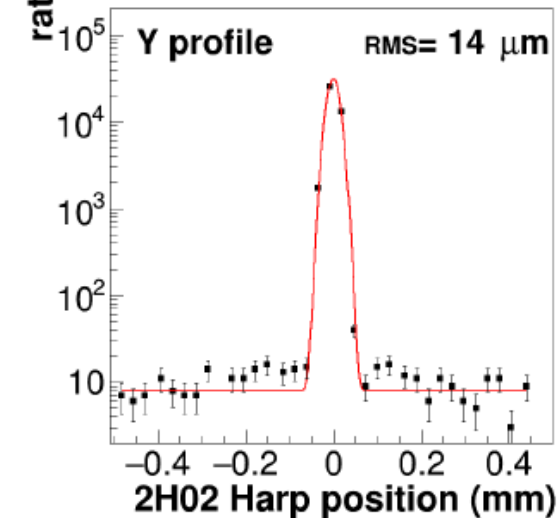
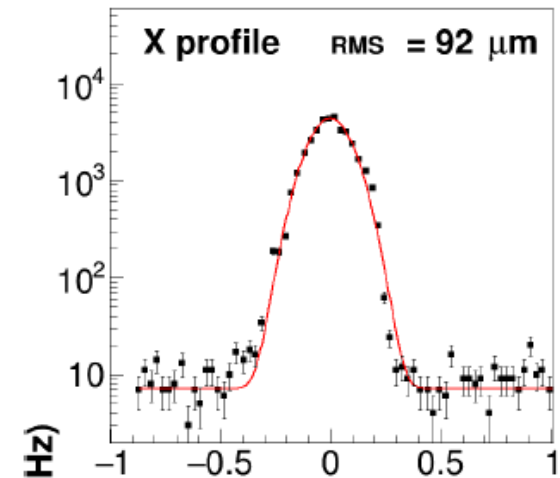
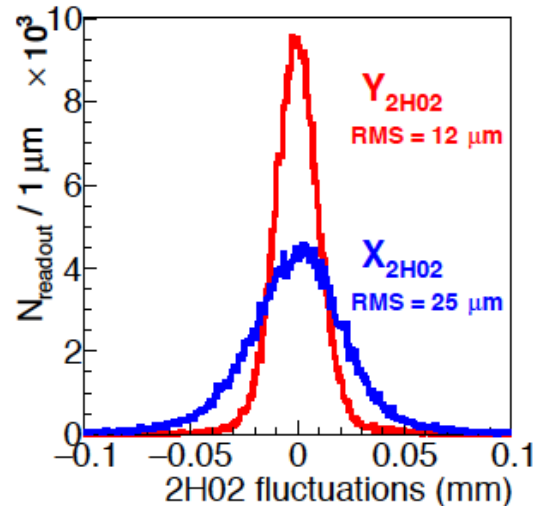
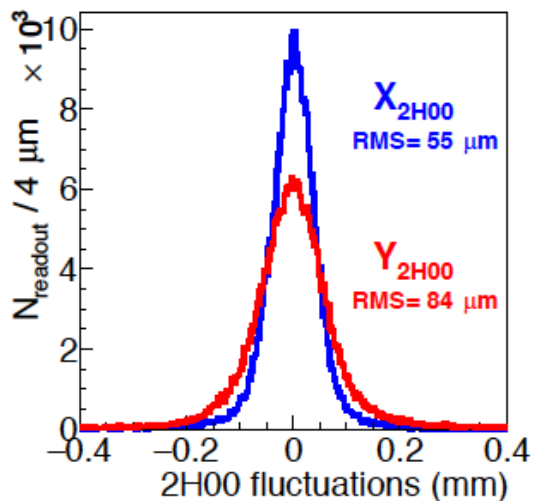

ECal Performance

- Lead-tungstate calorimeter with 442 16 cm long crystals (1.3x.1.3 cm² cross section) with APD readout (Hamamatsu S8664-1010)
- All channels worked, max rate around the electron beam exit ~1MHz
- Initial calibrations with cosmic muons was sufficient for the trigger setup
- Good energy/time resolution
- 2-cluster time coincidence leaves <1% accidentals
- efficiency measured ~100%
- Provided trigger for DAQ, with >95% efficiency (includes cluster reconstruction and position and energy analysis)
- **No changes to Ecal will be made for the next run**

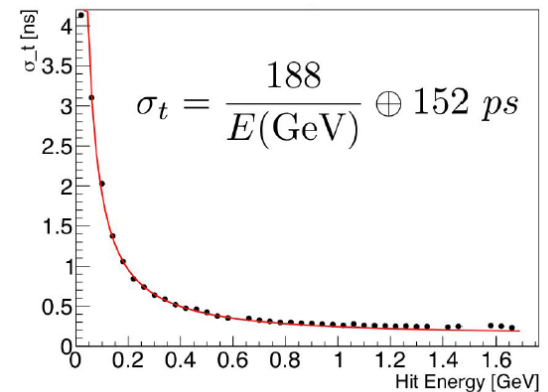
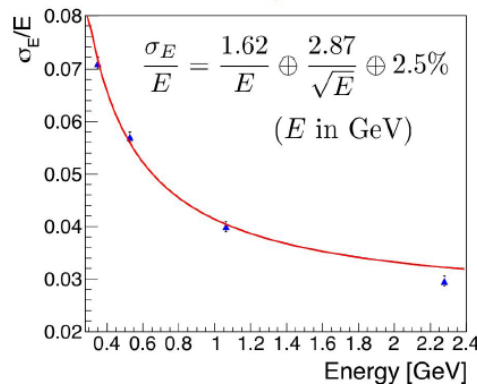
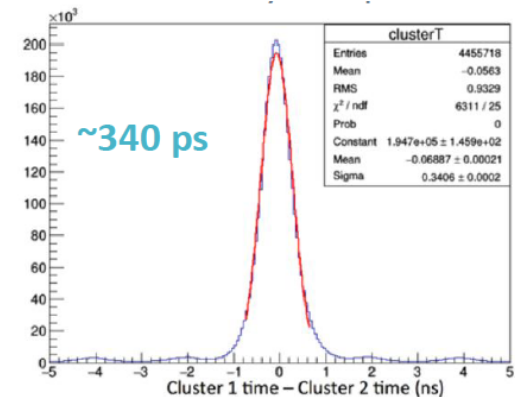
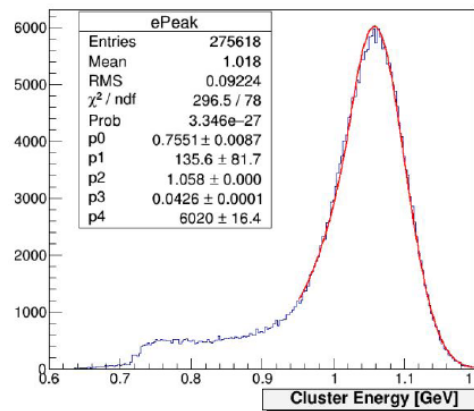

SVT Performance

- The edge of L1 is at 0.5 mm from the beam
- L1 occupancy $\leq 1\%$, hit efficiency $>95\%$
- Momentum resolution $\sim 7\%$ at 1 GeV
- The mass resolution within 10% of simulation
 - Moller $M(e^-e^-)$ used as benchmark
- Vertex resolution as expected

Z Vtx, Mass[0.0385, 0.0433],0.0409

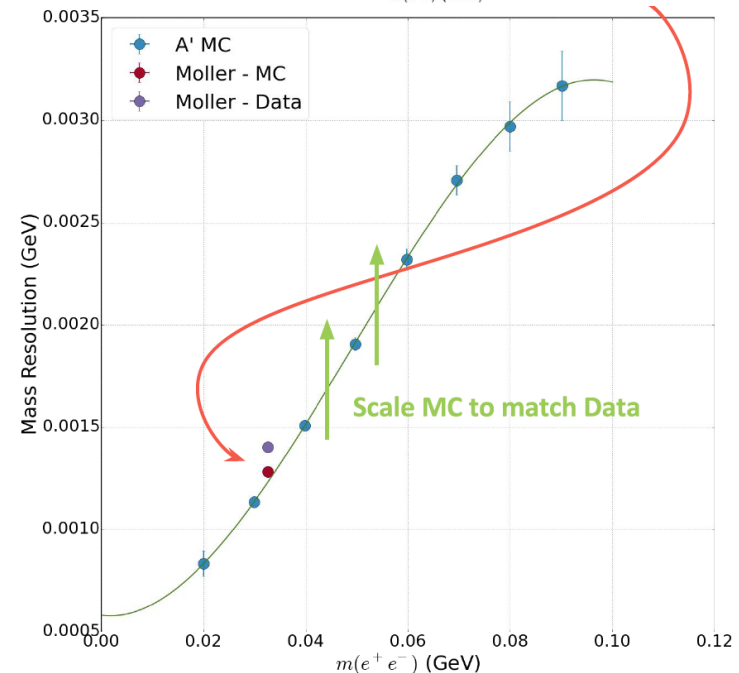
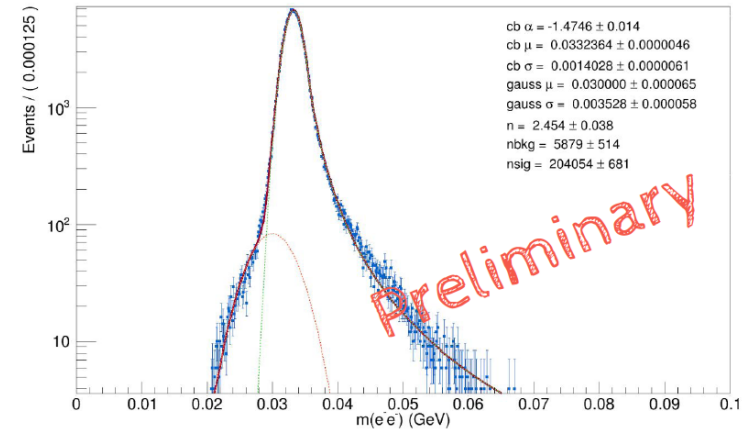
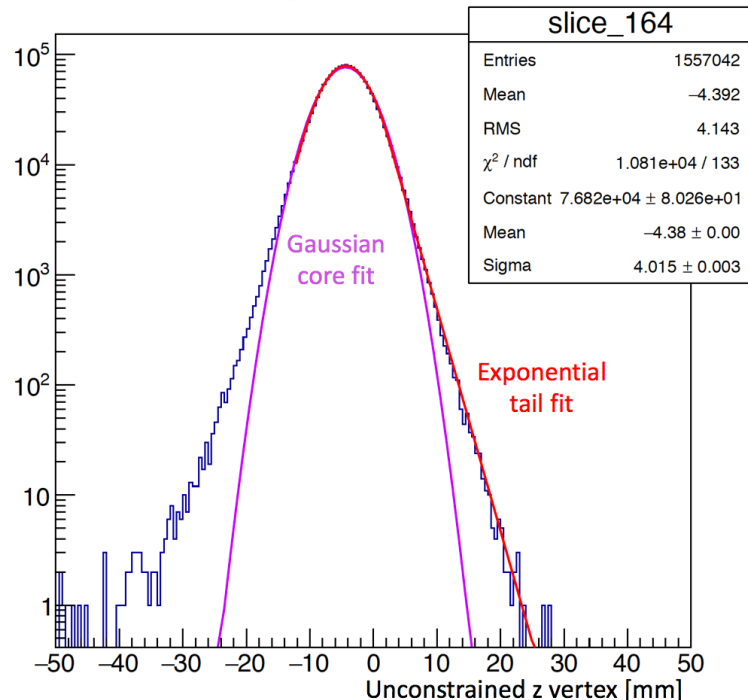

Status of Data Analysis

- 2015 data have been fully calibrated and processed
- Issues with event generators have been fixed:
 - replaced MG4 with MG5, normalization improved and
 - fixed target FF issue and use of wrong α value
 - move wide-angle brem. generation to MG4 because of wrong treatment of the scattered electron in EGS5
- Radiative trident fraction is correctly extracted
- Detector efficiencies well understood, good agreement between MC and data
- Two students graduated using 10% unblinded sample
- Full 2015 bump hunt unblinded and approved
- First bump hunt results have been presented at JLAB seminar

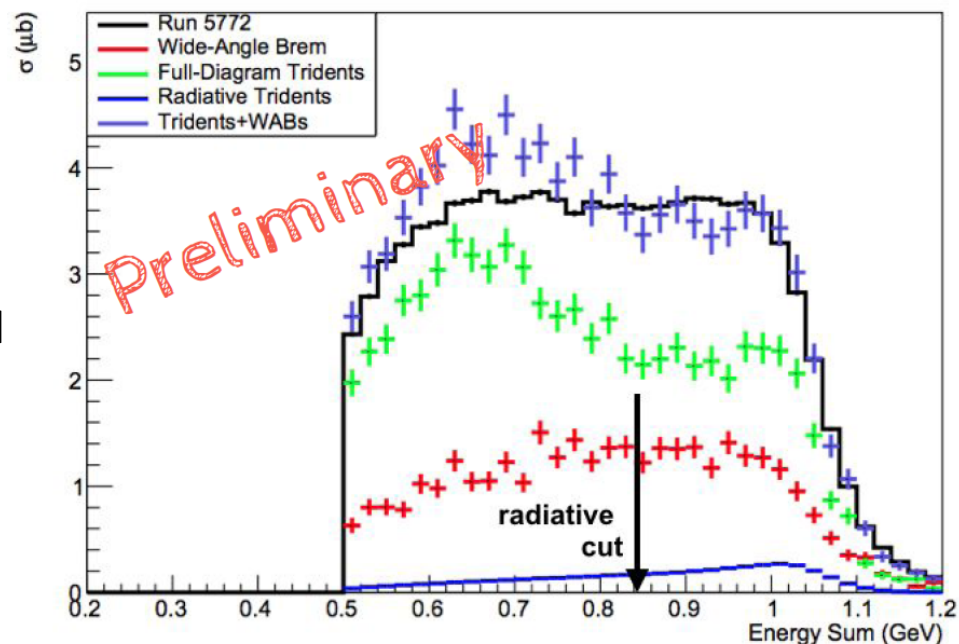

2015 Bump Hunt Results

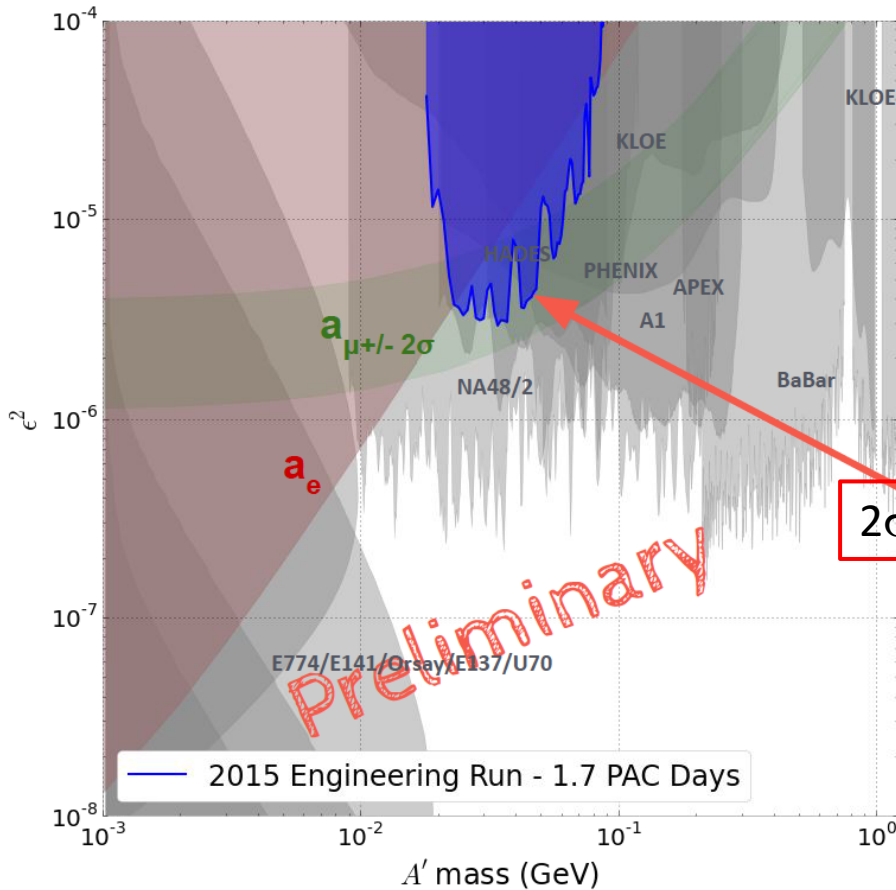

Final mass spectrum, 0.5 MeV bins

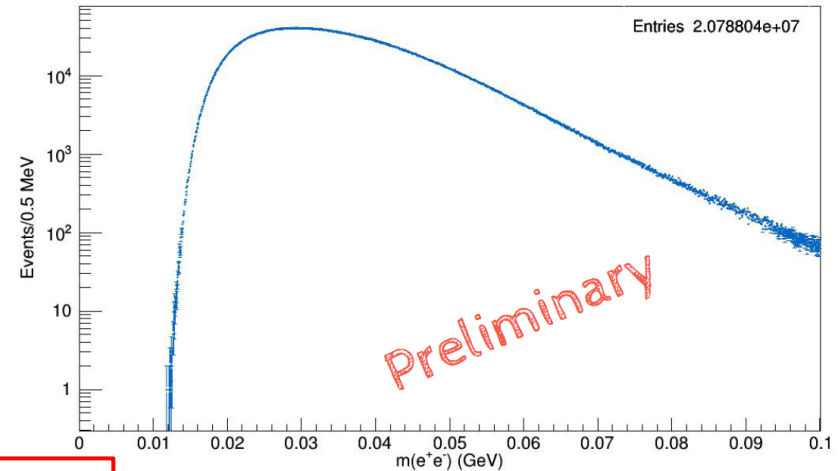

$$\epsilon^2 = \left(\frac{S_{\max} \cdot \delta m}{f \cdot \Delta B \cdot m_{A'}} \right) \times \left(\frac{2N_{\text{eff}}\alpha}{3\pi} \right)$$

S_{\max} – power constrained upper limit

f – radiative trident fraction

α – fine structure constant

$N_{\text{eff}} = 1$ – decay fraction to the SM model particles

ΔB – background/MeV

δm – mass resolution

$m_{A'}$ – A' mass

Analysis note is in preparations for the review. Expect to submit the first HPS physics publication this fall.

Why Upgrades (#1)

- Analysis of the HPS engineering run data showed worse than expected reach in both the bump hunt and the vertexing searches.
- These reach discrepancies between what we had projected in our proposal and what we measured experimentally were traced to two mistakes :
 1. we did not account for the "electron hole" in the ECAL acceptance. Nine modules were removed from the crystal rows nearest to the beam for each of the top and bottom ECAL halves because they suffered very high rates from scattered beam electrons. As it turns out, almost half of the pairs in our rough acceptance have the electron ending up in that hole, so they have been missing in our nominal trigger. Our pairs-1 trigger requires a coincidence of two clusters, one in each of the top and bottom ECAL.
 2. In the proposal for vertexing reach we had assumed constant acceptance for decay lengths out to 10 cm for electron-positron pair detection. The fall-off in efficiency for decays that occur more than 3 cm downstream of the target had not been properly accounted for.
- In order to mitigate these losses in our reach, two modest upgrades to the existing HPS setup are proposed:
 1. Add a new layer, Layer-0, 5 cm downstream of the target, and move Layers 2 and 3 closer to the beam. L0 will improve vertex resolution by x2 so the vertex cut will be closer to the target[§]. The L2 and 3 move will improve efficiency of reconstruction for decays far downstream of the target.
 2. Add scintillation counter in front of the ECal on the "positron" side to be used in the trigger to triggering on positrons only. The single arm trigger will allow to recover electrons lost the ECal hole.

[§]Layer-0 was proposed and being planned before we knew we had lost reach from the mistakes in the proposal.

HPS Beamline

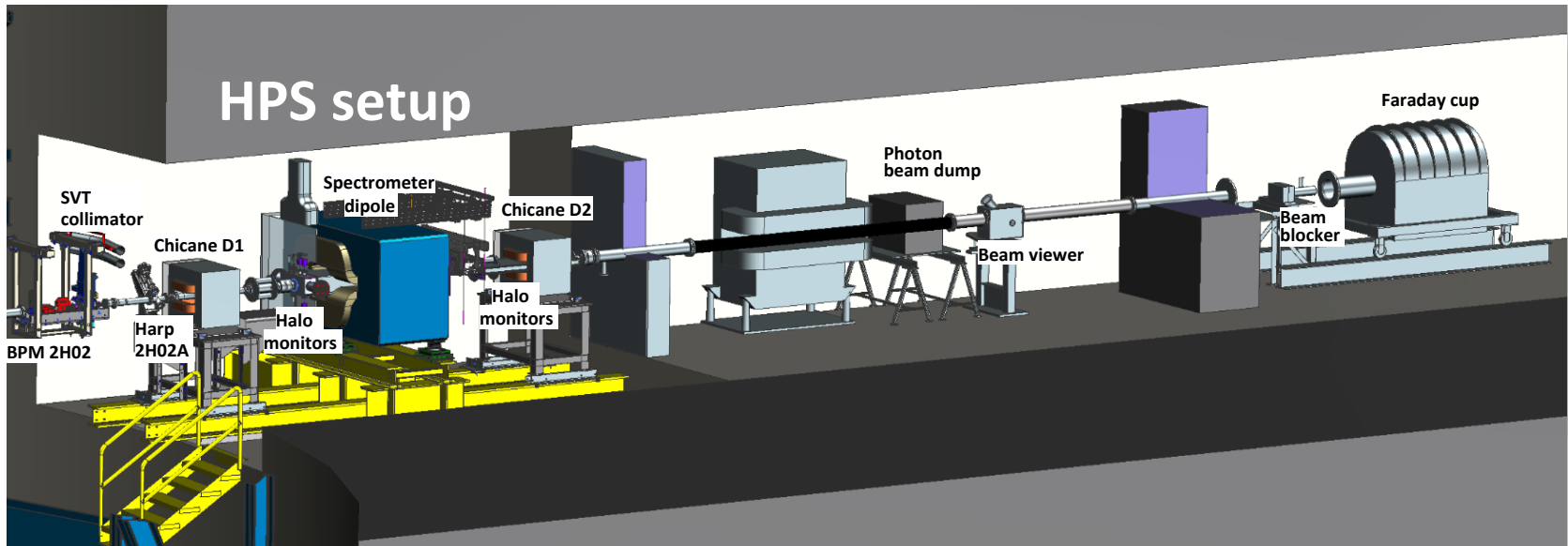

- To go from the CLAS12 operations to HPS the following has to be done:
 - remove beam pipe in the alcove, move HPS magnets to the running position
 - connect vacuum chambers to the beam pipes
 - install 2H02 BPM and the HPS SVT collimator
 - move cleanup collimator and 2H01 harp to the HPS location (will become 2H02A harp)

HPS configuration for 2018 run (#1)

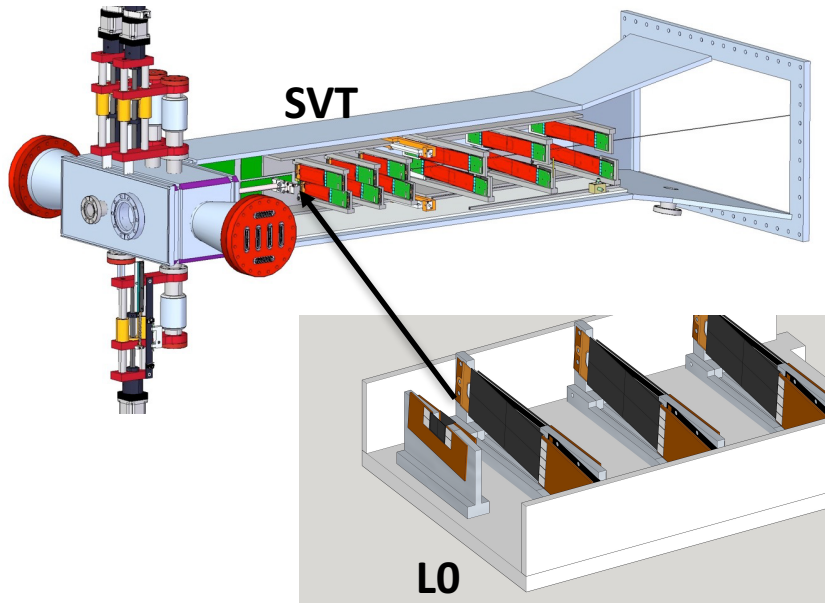
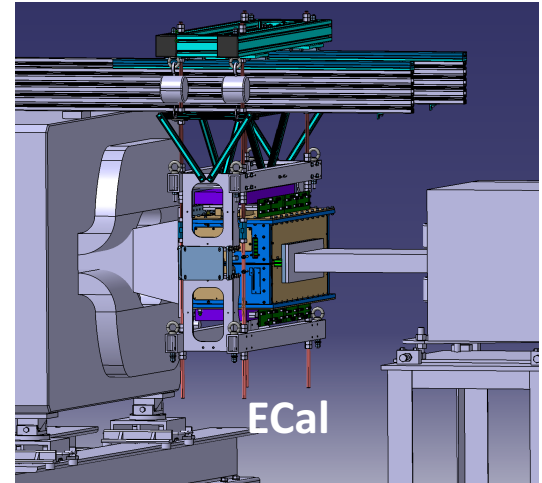
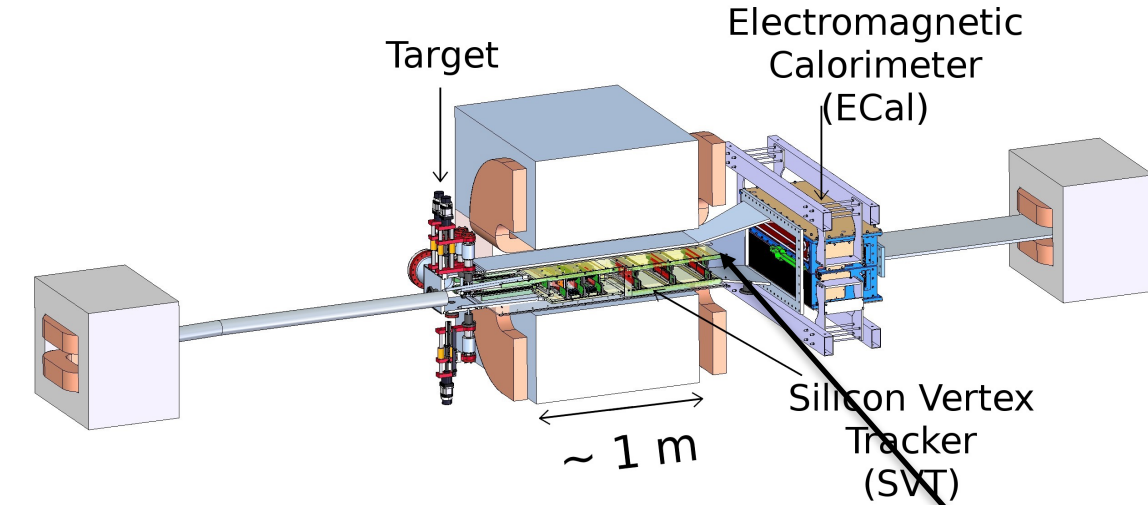

Hodoscope

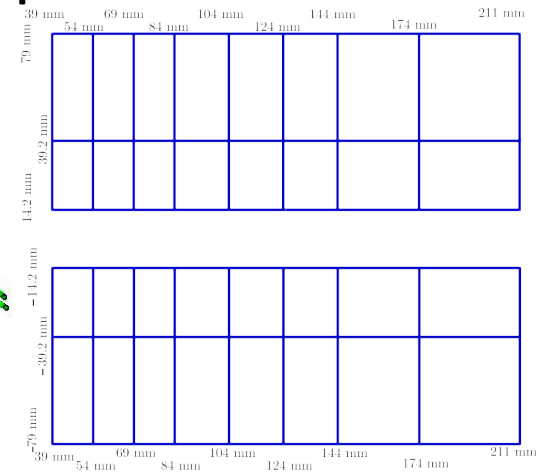
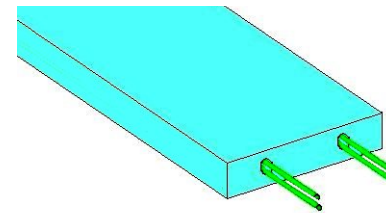

Beamline with CLAS12 (#2)

- CLAS12 uses the systems (beam transport, monitoring and controls) used by HPS for the engineering run.
- Beamline changes for CLAS12 are mainly in adding more shielding and collimators:
 - a shielding on top of the tagger dipole yoke
 - tungsten shield downstream of the CLAS12 target, and through the torus bore
 - poly. blocks for neutron shielding downstream of the collimator box
 - additional collimators have been added in the collimator box
- The only change in beam optics controls is the position of the 2H00 girder on the space frame. It will be 3 meters upstream from its original position (10% increase of the distance to the HPS target) that will not have impact on beam focusing at the HPS target.
- The beam fast shutdown system for CLAS12 uses the new FSD modules, with much improved hardware and firmware. The new system works the same way, accepts signals from halo counter and will allow to chose shorter trip times (<1 ms) than the old one.
- The new beam pipe through the tagger magnet eliminates the need to pump down the tagger vacuum chamber that will provide better beam vacuum in that region.

Hall-B beamline: 2H-line

Hall-B Beamline Upstream of the Target

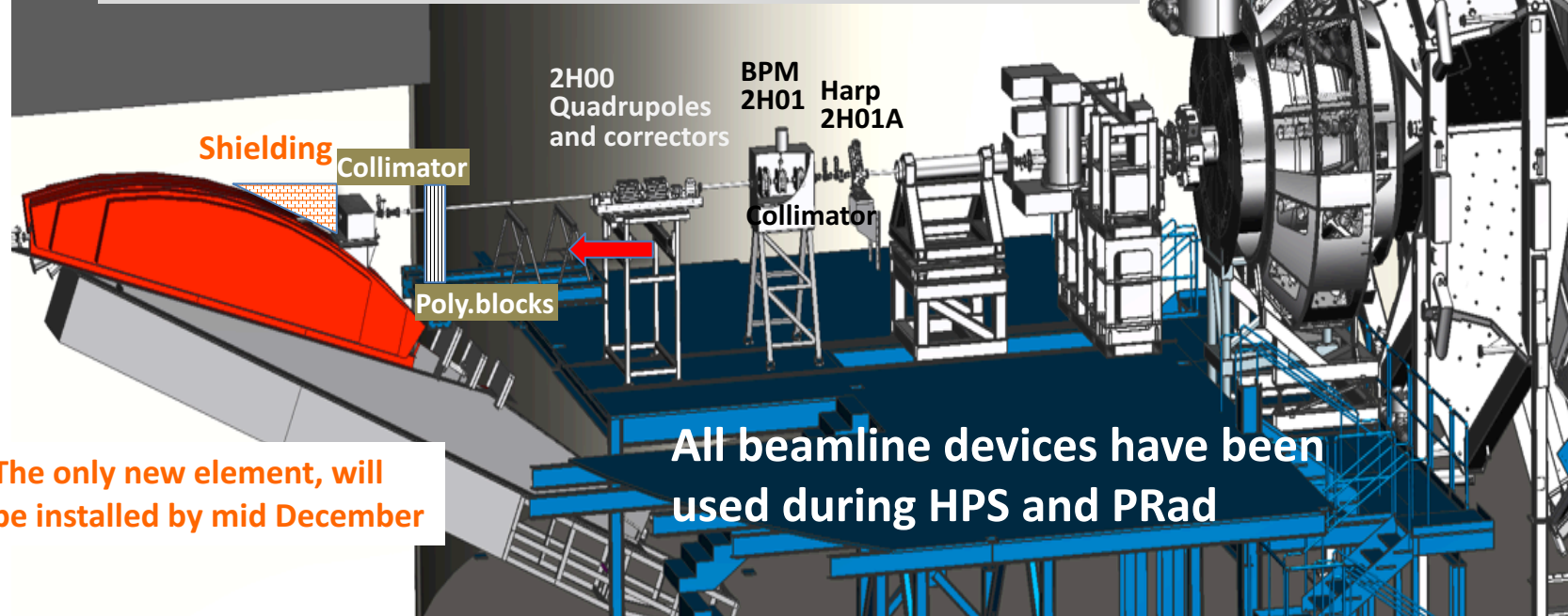

The only new element, will be installed by mid December

All beamline devices have been used during HPS and PRad

Hall-B Downstream Beamline

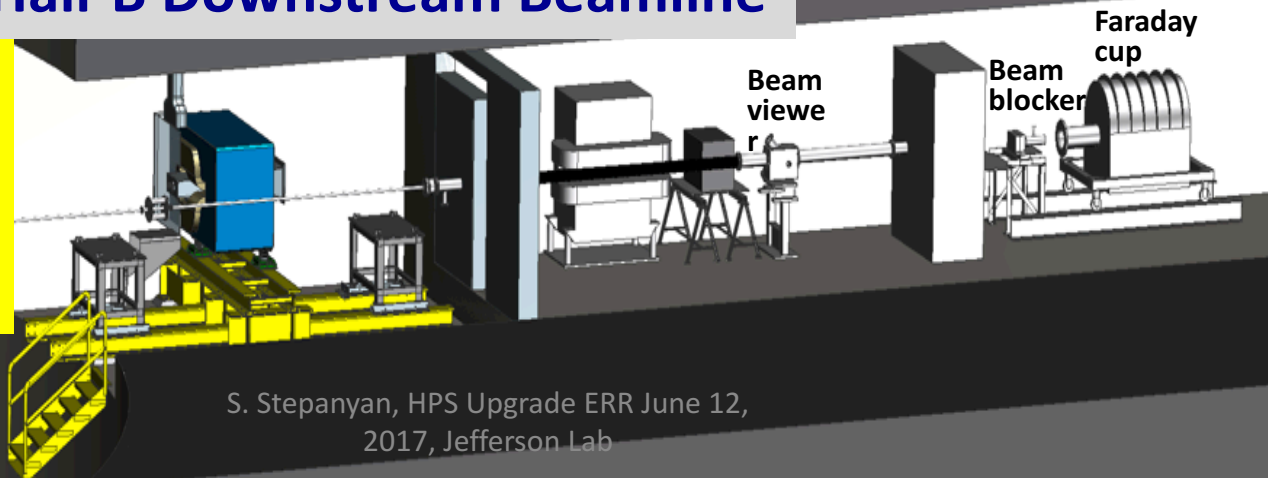

This configuration is for the engineering run.

For HPS, 2H01A harp will be re-located in front of the first chicane dipole

HPS to CLAS12 (#2)

- During the CLAS12 operations HPS will be moved out:
 - 2H02A harp and the cleanup collimator will be installed on the space frame (2H01 harp)
 - Upstream chicane dipole and 2H02 girder will be removed
 - Analyzing magnet will be moved to beam-right
 - Downstream chicane dipole will be lowered to the floor
 - 6" beam pipe then connects upstream and downstream beamline for CLAS12

- To go from the CLAS12 operations to HPS the following has to be done:
 - remove beam pipe in the alcove, move HPS magnets to the running position
 - connect vacuum chambers to the beam pipes
 - install 2H02 BPM and the HPS collimator
 - remove CLAS12 cryo-target
 - move cleanup collimator and 2H01 harp to the HPS location (will become 2H02A harp)
 - install the beam pipe through the torus and the CLAS12 CD
 - connect beam pipes and pump down

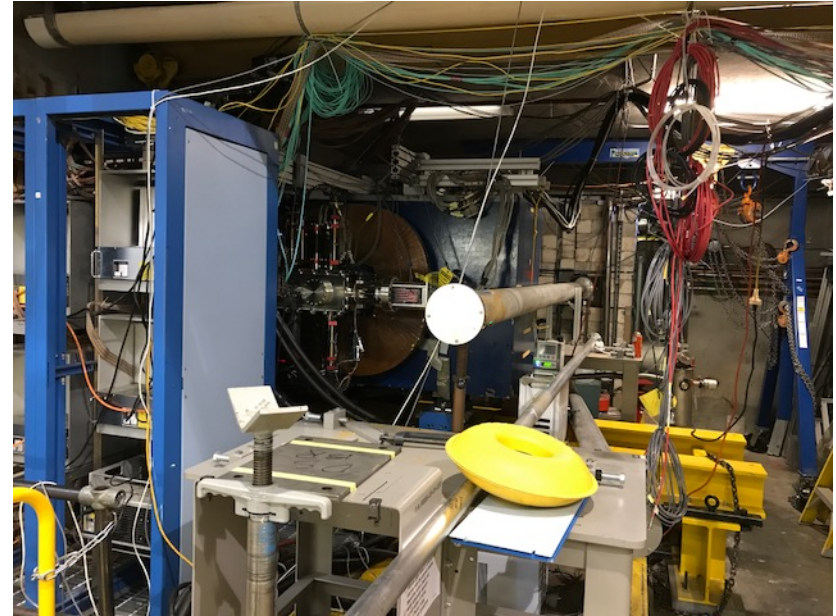

Radiation Levels (#5)

- Estimates of the radiological condition have been done initially in 2014 and include all running conditions proposed in the original HPS proposal
- The HPS RSAD has been updated in 2016 and will be updated before the next run
- No changes to the targets or beam current request are anticipated for the upcoming run. The only expected change in terms of radiation control is the possibility of having a rapid access for Hall-B (we did not had it during the engineering run due to insufficient number of monitors)
- **Proposed upgrades will not change radiological conditions in the Hall or around the HOPS setup in downstream alcove.**
- For CLAS12 operations more shielding has been added to the beamline, right downstream of the tagger magnet. This new shield will in fact improve radiation background on HPS.
- The beam transport and beam dump stays unchanged from what was present during the engineering runs . CLAS12 uses the same beam transport systems and the same beam dump.

Documentation (#6)

Jefferson Lab > Physics > Hall B Privacy and Security Notice

Experimental Hall B

Hall B Main CLAS CLAS12 Other Expts Run Info Publications Public Interest print version

Current Run Information



HEAVY PHOTON SEARCH

- [HPS Run page](#)
- [HPS Conduct of Operations \(COO\)](#)
- [HPS Experiment Safety Assessment Document \(ESAD\)](#)
- [HPS Radiation Safety Assessment Document \(RSAD\)](#)
- [Hall-B Emergency Response Guidelines \(ERG\)](#)

- [Electronic Logbook Entries](#)
- [Accelerator and Experimental Schedule](#)
- [HPS Shift Schedules](#)
- [HPS Collaboration page](#)
- Email archives: [HPS](#)

12000 Jefferson Avenue, Newport News, VA 23606 contact Volker Burkert
updated June 9, 2014
Phone: (757) 269-7821 Fax: (757) 269-7848

- The run-page exists (the same page will be used)
- The documentation from the engineering run will be updated as needed:
 - COO will only need an update for PDL (a new PDL may be assigned)
 - ESAD has been updated to include the new scintillation hodoscope
 - RSAD is the same, will be reviewed ones more before the run (as had been done for 2016 run)
- Detector operations manuals and procedures will be updated as needed
- Will need an operations manual for hodoscope (expected to have by end of 2017)
- Hot-checkout system will be used as before (now it includes also full CLAS12 and has been used for CLAS12 KPP)

Tentative Run Plan for 2018

- A new reach estimate includes upgraded SVT and the trigger setup with the new hodoscope
- HPS engineering runs were run at 1.05 GeV and 2.3 GeV with very limited beam time
- For the next run we plan to use 4.4 GeV beam. Data taking must be at least 4 PAC weeks long
- With minor changes to the beamline and a new energy regime, ~5 days of commissioning will be needed, as well as ~5 days for calibration runs will be needed (0-field, empty target, carbon target, different trigger runs)

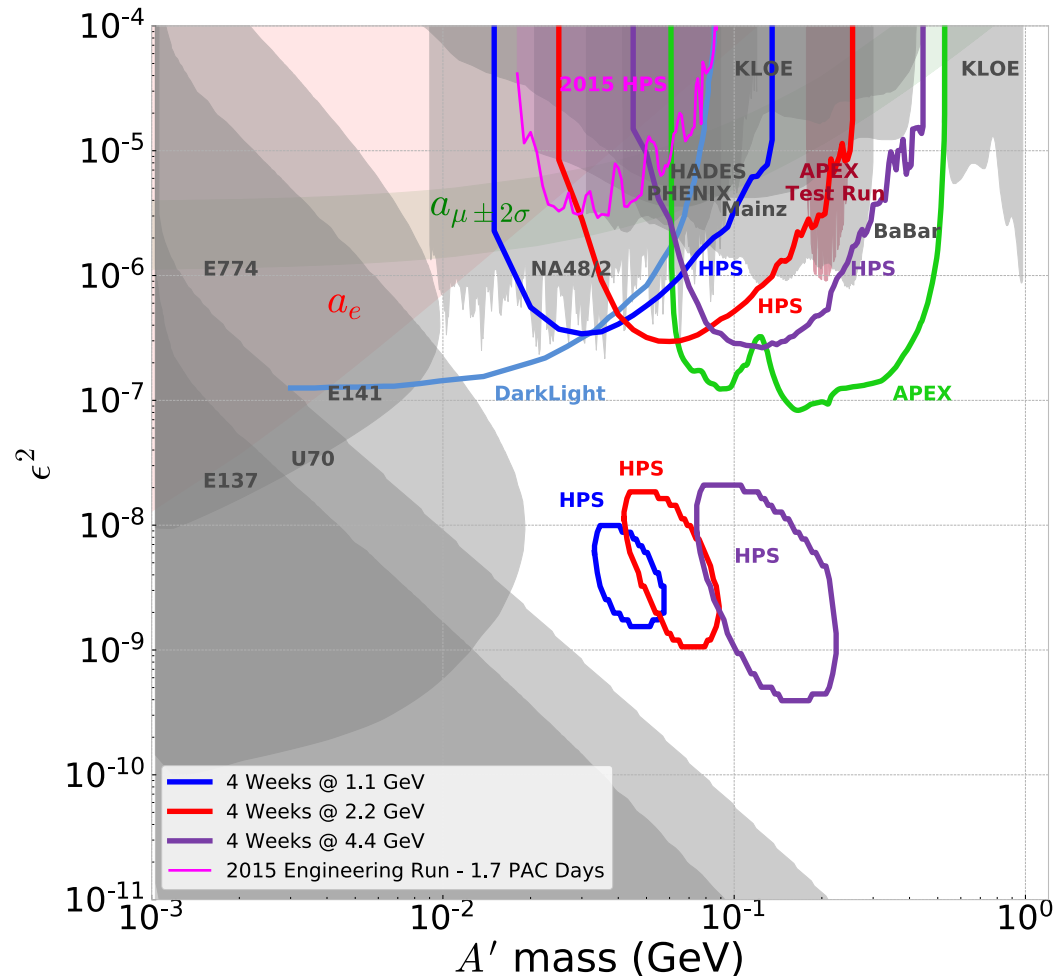

Total of 40 PAC days at 4.4 GeV will be requested for the next run

Summary

- HPS has successfully completed engineering runs in 2015 and 2016, at 1.05 GeV and 2.3 GeV, respectively.
- Based on the HPS performance, JLAB management granted the full approval to HPS.
- The bump hunt result from 2015 run has been released (May 3 seminar at JLAB).
- The actual reach turned out to be smaller than what we originally estimated in our proposal.
- This discrepancy was traced to the mistakes in the detector efficiency estimates due the electron “hole” in ECal and the vertex dependent acceptance for long lived decays.
- Proposed upgrades to the tracker, and the trigger system will mitigate these issues.
- The HPS beamline will have minor changes necessary for CLAS12 operation. The target, Ecal, slow-controls and DAQ will remain unchanged.
- Transition from CLAS12 to HPS requires only minor configuration change.