

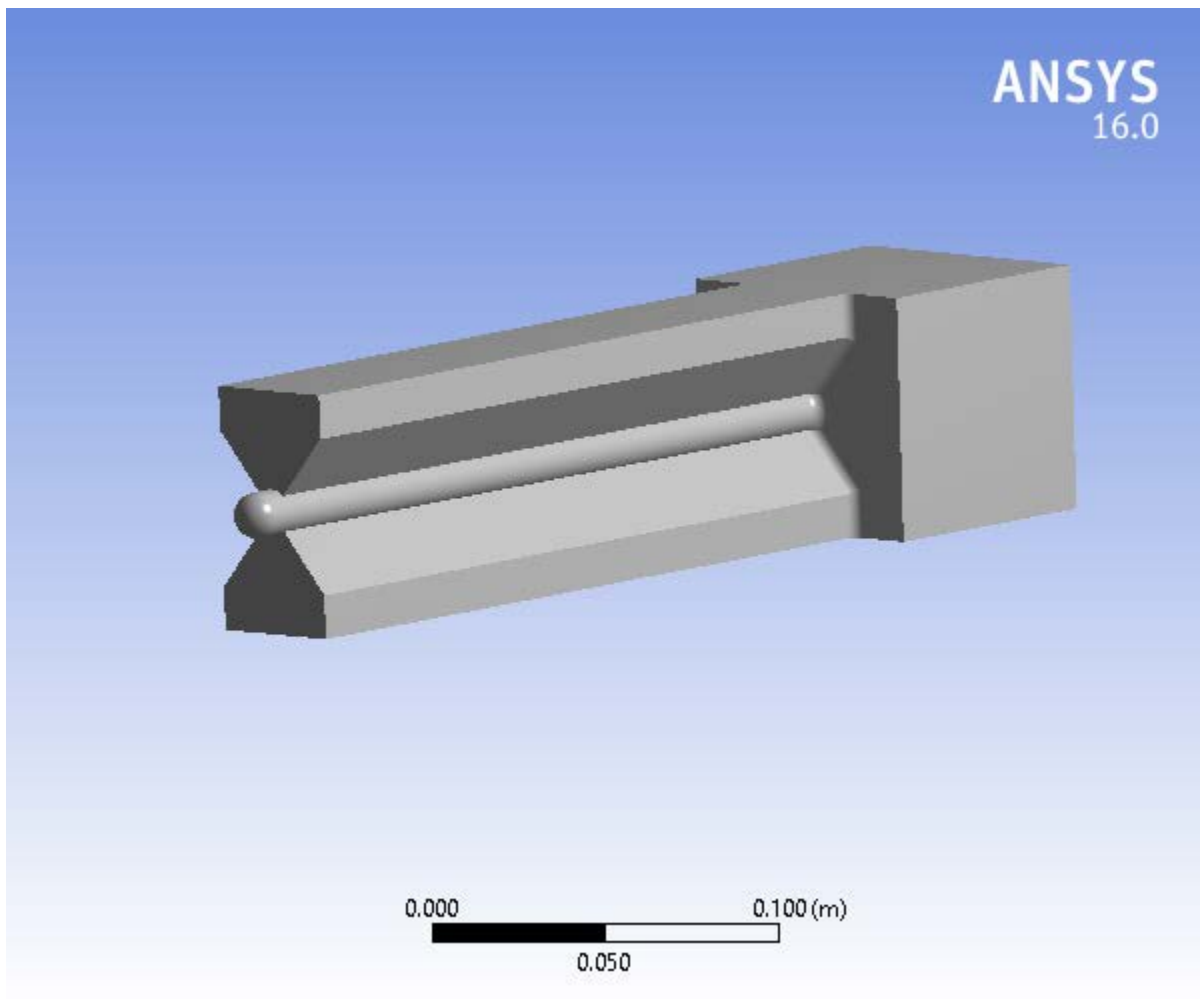

Thermal analysis of main body

Author	Dave Meekins
Subject	TGT-CALC-103-013
First Saved	Saturday, August 22, 2015
Last Saved	Friday, August 28, 2015
Product Version	16.0 Release
Save Project Before Solution	No
Save Project After Solution	No



Contents

- Units
- Model (E4)
 - Geometry
 - Parts
 - Coordinate Systems
 - Connections
 - Contacts
 - Bonded - main body:1 To exit beam:1
 - Mesh
 - Steady-State Thermal (E5)
 - Initial Temperature
 - Analysis Settings
 - Loads
 - Solution (E6)
 - Solution Information
 - Temperature
- Material Data
 - 7075 (UNS A97075)

Units

TABLE 1

Unit System	Metric (m, kg, N, s, V, A) Degrees rad/s Kelvin
Angle	Degrees
Rotational Velocity	rad/s
Temperature	Kelvin

Comment

Thermal analysis of main body

Assumptions are:

- beam current 20 microA
- raster 2x2 mm
- beam heat load 3.3W
- heat flux from beam $3E+9 \text{ W/m}^3$
- Material model from MPDB

Model (E4)

Geometry

TABLE 2
Model (E4) > Geometry

Object Name	Geometry
State	Fully Defined
Definition	
Source	D:\Meekins\GoogleDrive\JLAB\Hall A\Trtium\Calculations\ANSYS\cell beam heating\Assembly1.iam
Type	Inventor
Length Unit	Centimeters
Element Control	Program Controlled
Display Style	Body Color
Bounding Box	
Length X	0.33416 m
Length Y	7.0806e-002 m
Length Z	7.62e-002 m
Properties	
Volume	8.0156e-004 m ³
Mass	2.1799 kg
Scale Factor Value	1.
Statistics	
Bodies	4
Active Bodies	2
Nodes	279855
Elements	163068
Mesh Metric	None
Basic Geometry Options	
Solid Bodies	Yes
Surface Bodies	Yes
Line Bodies	No
Parameters	Yes
Parameter Key	DS
Attributes	No
Named Selections	No
Material Properties	No
Advanced Geometry Options	
Use Associativity	Yes
Coordinate Systems	No
Reader Mode Saves Updated File	No
Use Instances	Yes
Smart CAD Update	No
Compare Parts On Update	No
Attach File Via Temp File	Yes
Temporary Directory	C:\Users\David\AppData\Local\Temp
Analysis Type	3-D
Mixed Import Resolution	None
Decompose Disjoint Geometry	Yes

Enclosure and Symmetry Processing	Yes
-----------------------------------	-----

TABLE 3
Model (E4) > Geometry > Parts

Object Name	<i>main body:1</i>	<i>entrance:1</i>	<i>exit beam:1</i>	<i>ent beam:1</i>
State	Meshed	Suppressed	Meshed	Suppressed
Graphics Properties				
Visible	Yes	No	Yes	No
Transparency	1		1	
Definition				
Suppressed	No	Yes	No	Yes
Stiffness Behavior	Flexible			
Coordinate System	Default Coordinate System			
Reference Temperature	By Environment			
Material				
Assignment	7075 (UNS A97075)			
Nonlinear Effects	Yes			
Thermal Strain Effects	Yes			
Bounding Box				
Length X	0.32146 m	8.4557e-002 m	3.5536e-004 m	3.0437e-004 m
Length Y	7.0806e-002 m	6.985e-002 m	2.26e-003 m	
Length Z	7.62e-002 m	6.985e-002 m	2.26e-003 m	
Properties				
Volume	8.0156e-004 m ³	5.3773e-005 m ³	1.2217e-009 m ³	1.0189e-009 m ³
Mass	2.1799 kg	0.14624 kg	3.3224e-006 kg	2.7711e-006 kg
Centroid X	1.2664e-002 m	0.12855 m	-0.19035 m	6.0903e-002 m
Centroid Y	8.7826e-002 m			
Centroid Z	3.3853e-002 m	3.3854e-002 m		
Moment of Inertia Ip1	1.7753e-003 kg·m ²	7.4106e-005 kg·m ²	2.2426e-012 kg·m ²	1.7625e-012 kg·m ²
Moment of Inertia Ip2	1.9153e-002 kg·m ²	9.6097e-005 kg·m ²	1.1487e-012 kg·m ²	8.9668e-013 kg·m ²
Moment of Inertia Ip3	1.9637e-002 kg·m ²	9.6097e-005 kg·m ²	1.1488e-012 kg·m ²	8.9668e-013 kg·m ²
Statistics				
Nodes	279067	0	788	0
Elements	162946	0	122	0
Mesh Metric	None			

Coordinate Systems

TABLE 4
Model (E4) > Coordinate Systems > Coordinate System

Object Name	<i>Global Coordinate System</i>
State	Fully Defined
Definition	
Type	Cartesian

Coordinate System ID	0.
Origin	
Origin X	0. m
Origin Y	0. m
Origin Z	0. m
Directional Vectors	
X Axis Data	[1. 0. 0.]
Y Axis Data	[0. 1. 0.]
Z Axis Data	[0. 0. 1.]

Connections

TABLE 5
Model (E4) > Connections

Object Name	<i>Connections</i>
State	Fully Defined
Auto Detection	
Generate Automatic Connection On Refresh	Yes
Transparency	
Enabled	Yes

TABLE 6
Model (E4) > Connections > Contacts

Object Name	<i>Contacts</i>
State	Fully Defined
Definition	
Connection Type	Contact
Scope	
Scoping Method	Geometry Selection
Geometry	All Bodies
Auto Detection	
Tolerance Type	Slider
Tolerance Slider	0.
Tolerance Value	8.7494e-004 m
Use Range	No
Face/Face	Yes
Face/Edge	No
Edge/Edge	No
Priority	Include All
Group By	Bodies
Search Across	Bodies
Statistics	
Connections	1
Active Connections	1

TABLE 7
Model (E4) > Connections > Contacts > Contact Regions

Object Name	<i>Bonded - main body:1 To exit beam:1</i>
State	Fully Defined

Scope	
Scoping Method	Geometry Selection
Contact	1 Face
Target	1 Face
Contact Bodies	main body:1
Target Bodies	exit beam:1
Definition	
Type	Bonded
Scope Mode	Manual
Behavior	Program Controlled
Trim Contact	Program Controlled
Suppressed	No
Advanced	
Formulation	Program Controlled
Detection Method	Program Controlled
Elastic Slip Tolerance	Program Controlled
Thermal Conductance	Program Controlled
Pinball Region	Program Controlled
Geometric Modification	
Contact Geometry Correction	None
Target Geometry Correction	None

Mesh

TABLE 8
Model (E4) > Mesh

Object Name	<i>Mesh</i>
State	Solved
Display	
Display Style	Body Color
Defaults	
Physics Preference	Mechanical
Relevance	0
Sizing	
Use Advanced Size Function	Off
Relevance Center	Fine
Element Size	Default
Initial Size Seed	Active Assembly
Smoothing	High
Transition	Slow
Span Angle Center	Fine
Minimum Edge Length	4.9873e-003 m
Inflation	
Use Automatic Inflation	Program Controlled
Inflation Option	Smooth Transition
Transition Ratio	0.272
Maximum Layers	5
Growth Rate	1.2

Inflation Algorithm	Pre
View Advanced Options	No
Patch Conforming Options	
Triangle Surface Mesher	Program Controlled
Patch Independent Options	
Topology Checking	No
Advanced	
Number of CPUs for Parallel Part Meshing	Program Controlled
Shape Checking	Standard Mechanical
Element Midside Nodes	Program Controlled
Straight Sided Elements	No
Number of Retries	Default (4)
Extra Retries For Assembly	Yes
Rigid Body Behavior	Dimensionally Reduced
Mesh Morphing	Disabled
Defeaturing	
Pinch Tolerance	Please Define
Generate Pinch on Refresh	No
Automatic Mesh Based Defeaturing	On
Defeaturing Tolerance	Default
Statistics	
Nodes	279855
Elements	163068
Mesh Metric	None

Steady-State Thermal (E5)

TABLE 9
Model (E4) > Analysis

Object Name	<i>Steady-State Thermal (E5)</i>
State	Solved
Definition	
Physics Type	Thermal
Analysis Type	Steady-State
Solver Target	Mechanical APDL
Options	
Generate Input Only	No

TABLE 10
Model (E4) > Steady-State Thermal (E5) > Initial Condition

Object Name	<i>Initial Temperature</i>
State	Fully Defined
Definition	
Initial Temperature	Uniform Temperature
Initial Temperature Value	40. K

TABLE 11
Model (E4) > Steady-State Thermal (E5) > Analysis Settings

Object Name	<i>Analysis Settings</i>	
State	Fully Defined	
Step Controls		
Number Of Steps	1.	
Current Step Number	1.	
Step End Time	1. s	
Auto Time Stepping	Program Controlled	
Solver Controls		
Solver Type	Program Controlled	
Solver Pivot Checking	Program Controlled	
Radiosity Controls		
Radiosity Solver	Program Controlled	
Flux Convergence	1.e-004	
Maximum Iteration	1000.	
Solver Tolerance	0.1 W/m ²	
Over Relaxation	0.1	
Hemicube Resolution	10.	
Nonlinear Controls		
Heat Convergence	Program Controlled	
Temperature Convergence	Program Controlled	
Line Search	Program Controlled	
Output Controls		
Calculate Thermal Flux	Yes	
General Miscellaneous	No	
Store Results At	All Time Points	
Analysis Data Management		
Solver Files Directory	D:\Meekins\GoogleDrive\JLAB\Hall A\Trtium\Calculations\ANSYS\cell beam heating\beam heating_files\dp0\SYS-1\MECH\	
Future Analysis	None	
Scratch Solver Files Directory		
Save MAPDL db	No	
Delete Unneeded Files	Yes	
Nonlinear Solution	Yes	
Solver Units	Active System	
Solver Unit System	mks	

TABLE 12
Model (E4) > Steady-State Thermal (E5) > Loads

Object Name	<i>Temperature</i>	<i>Internal Heat Generation</i>
State	Fully Defined	
Scope		
Scoping Method	Geometry Selection	
Geometry	1 Face	1 Body
Definition		

Type	Temperature	Internal Heat Generation
Magnitude	40. K (ramped)	3.e+009 W/m ³ (ramped)
Suppressed		No

FIGURE 1
Model (E4) > Steady-State Thermal (E5) > Temperature

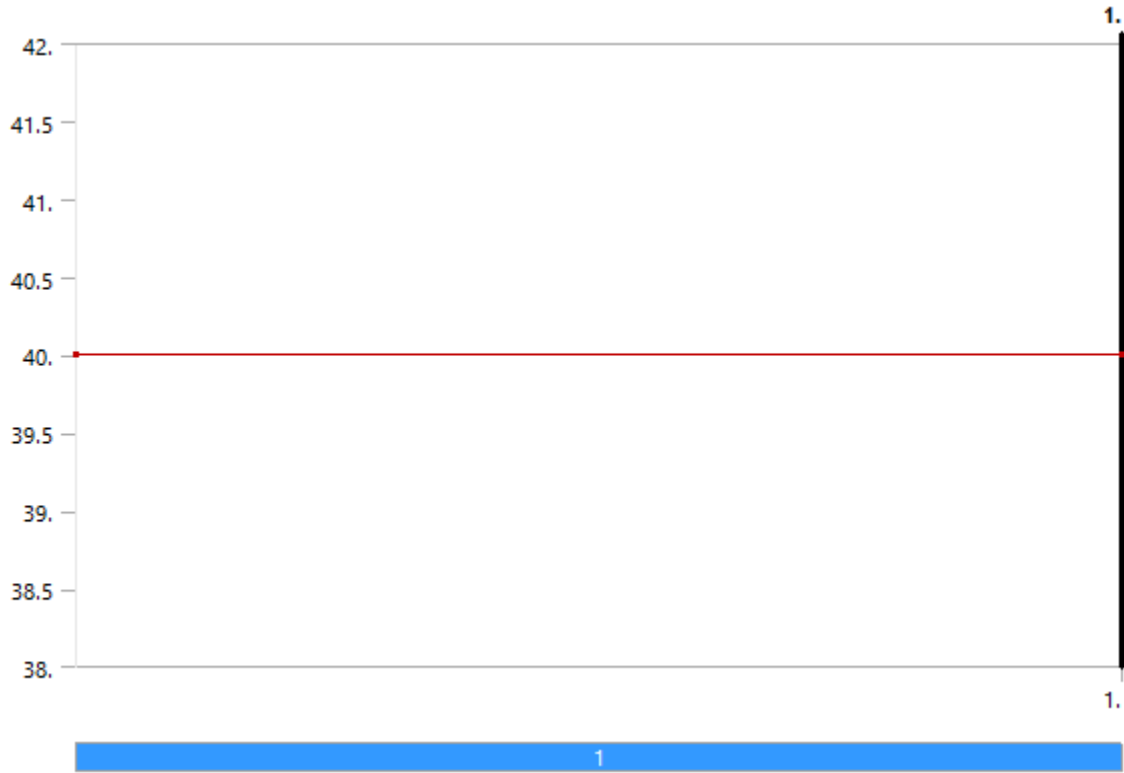
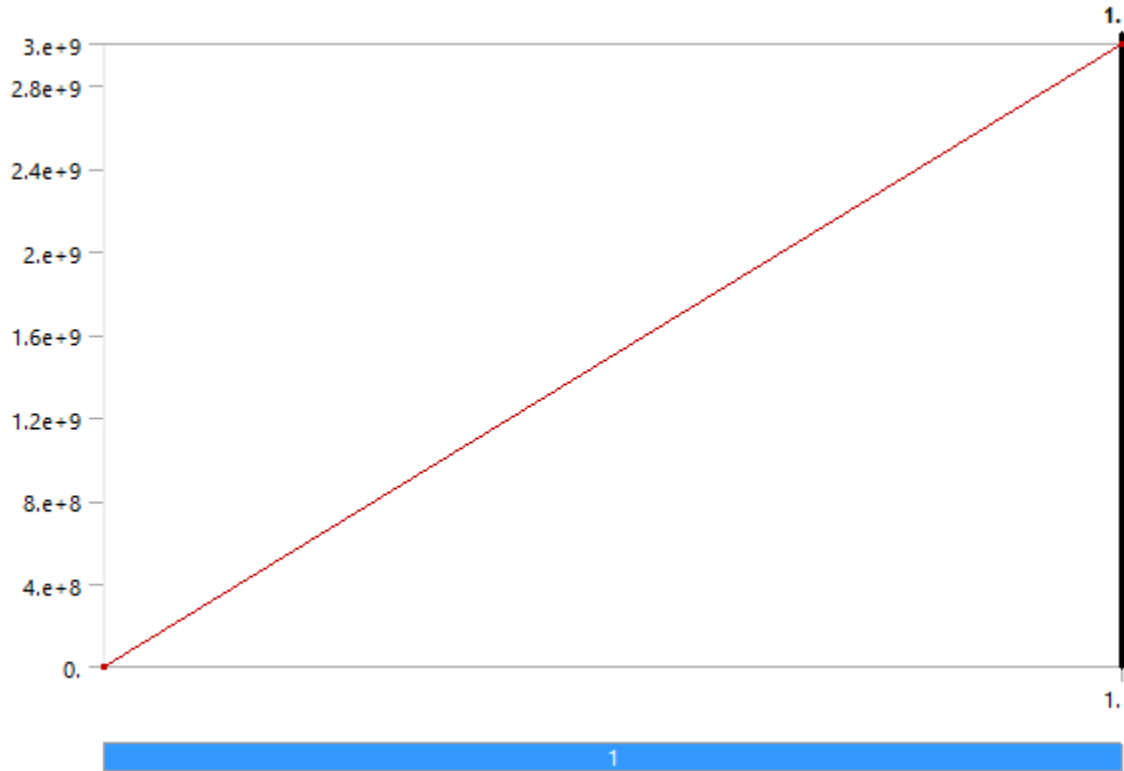

FIGURE 2
Model (E4) > Steady-State Thermal (E5) > Internal Heat Generation



Solution (E6)

TABLE 13
Model (E4) > Steady-State Thermal (E5) > Solution

Object Name	<i>Solution (E6)</i>
State	Solved
Adaptive Mesh Refinement	
Max Refinement Loops	1.
Refinement Depth	2.
Information	
Status	Done
Post Processing	
Calculate Beam Section Results	No

TABLE 14
Model (E4) > Steady-State Thermal (E5) > Solution (E6) > Solution Information

Object Name	<i>Solution Information</i>
State	Solved
Solution Information	
Solution Output	Solver Output
Update Interval	2.5 s
Display Points	All
FE Connection Visibility	
Activate Visibility	Yes
Display	All FE Connectors

Draw Connections Attached To	All Nodes
Line Color	Connection Type
Visible on Results	No
Line Thickness	Single
Display Type	Lines

TABLE 15
Model (E4) > Steady-State Thermal (E5) > Solution (E6) > Results

Object Name	<i>Temperature</i>
State	Solved
Scope	
Scoping Method	Geometry Selection
Geometry	All Bodies
Definition	
Type	Temperature
By	Time
Display Time	Last
Calculate Time History	Yes
Identifier	
Suppressed	No
Results	
Minimum	40. K
Maximum	124. K
Minimum Occurs On	main body:1
Maximum Occurs On	exit beam:1
Information	
Time	1. s
Load Step	1
Substep	1
Iteration Number	2

FIGURE 3
Model (E4) > Steady-State Thermal (E5) > Solution (E6) > Temperature

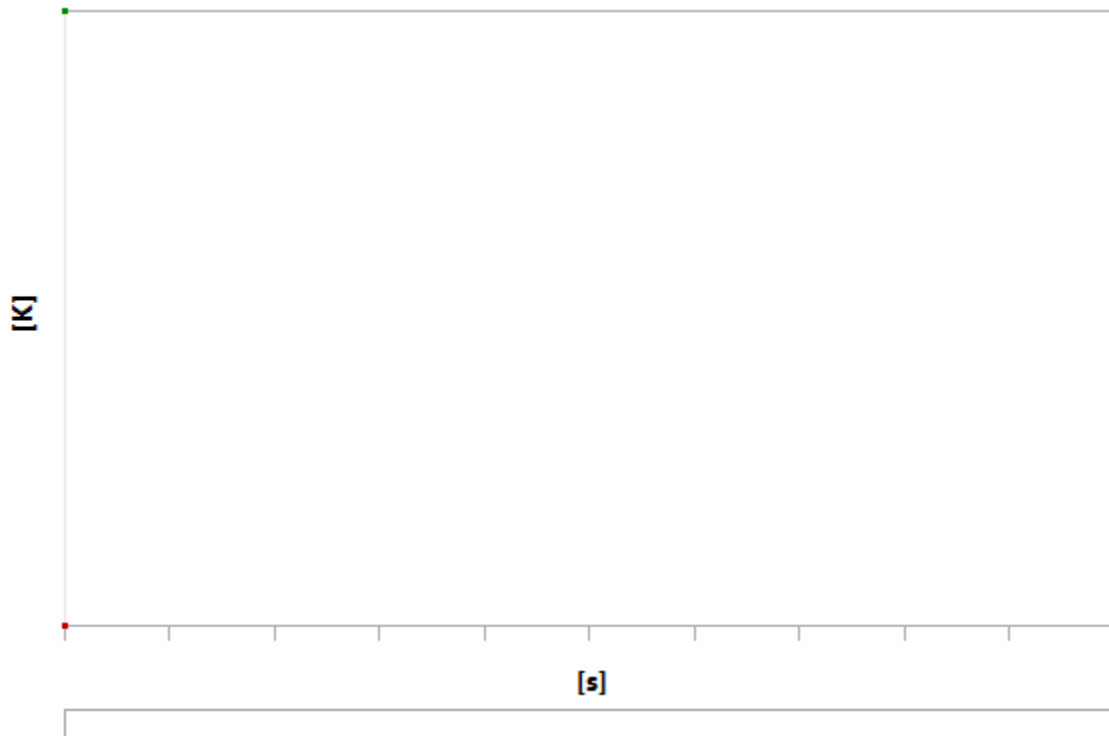

TABLE 16
Model (E4) > Steady-State Thermal (E5) > Solution (E6) > Temperature

Time [s]	Minimum [K]	Maximum [K]
1.	40.	124.

FIGURE 4
Model (E4) > Steady-State Thermal (E5) > Solution (E6) > Temperature > Figure
Temperature in main body

E: Steady-State Thermal

Figure
Type: Temperature
Unit: K
Time: 1
8/28/2015 1:33 AM

ANSYS
16.0

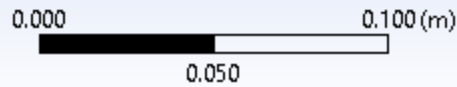
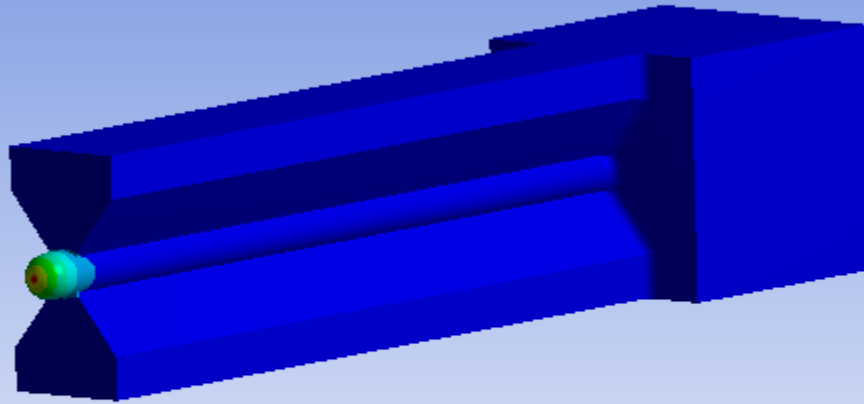
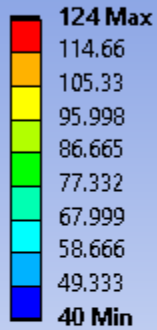

Material Data

7075 (UNS A97075)

TABLE 17
7075 (UNS A97075) > Density

Density kg m ⁻³	Temperature C
2754.3	-273.15
2754.3	-266.08
2754.2	-259.01
2754.2	-251.94
2754.3	-244.87
2754.2	-237.8
2754.1	-230.73
2753.9	-223.66
2753.6	-216.58
2753.2	-209.51
2752.7	-202.44

2752.2	-195.37
2751.7	-188.3
2751	-181.23
2750.4	-174.16
2749.6	-167.09
2748.8	-160.02
2748	-152.95
2747.2	-145.88
2746.2	-138.81
2745.3	-131.74
2744.3	-124.67
2743.3	-117.59
2742.3	-110.52
2741.2	-103.45
2740.1	-96.382
2739	-89.312
2737.9	-82.241
2736.7	-75.17
2735.6	-68.099
2734.4	-61.029
2733.2	-53.958
2732	-46.887
2730.7	-39.817
2729.5	-32.746
2728.2	-25.675
2727	-18.605
2725.7	-11.534
2724.4	-4.4631
2723.2	2.6076
2721.9	9.6783
2720.6	16.749
2719.3	23.82
2718	30.89
2716.6	37.961
2715.3	45.032
2714	52.103
2712.7	59.173
2711.3	66.244
2710	73.315
2708.7	80.385
2707.3	87.456
2706	94.527
2704.6	101.6
2703.3	108.67
2701.9	115.74
2700.5	122.81
2699.2	129.88
2697.8	136.95

2696.4	144.02
2695	151.09
2693.6	158.16
2692.2	165.23
2690.8	172.3
2689.4	179.38
2688	186.45
2686.5	193.52
2685.1	200.59
2683.6	207.66
2682.2	214.73
2680.7	221.8
2679.3	228.87
2677.8	235.94
2676.3	243.01
2674.8	250.08
2673.3	257.15
2671.7	264.22
2670.2	271.29
2668.7	278.37
2667.1	285.44
2665.6	292.51
2664	299.58
2662.4	306.65
2660.8	313.72
2659.2	320.79
2657.6	327.86
2656	334.93
2654.4	342
2652.8	349.07
2651.1	356.14
2649.5	363.21
2647.8	370.28
2646.2	377.36
2644.5	384.43
2642.9	391.5
2641.2	398.57
2639.6	405.64
2637.9	412.71
2636.3	419.78
2634.6	426.85

TABLE 18
7075 (UNS A97075) > Tensile Yield Strength

Tensile Yield Strength Pa	Temperature C
6.56e+008	-269.15
6.3812e+008	-260.98
6.2069e+008	-252.81
6.1153e+008	-244.63

6.029e+008	-236.46
5.9478e+008	-228.29
5.8716e+008	-220.12
5.8e+008	-211.95
5.7329e+008	-203.78
5.67e+008	-195.6
5.6111e+008	-187.43
5.5559e+008	-179.26
5.5041e+008	-171.09
5.4557e+008	-162.92
5.4103e+008	-154.75
5.3676e+008	-146.57
5.3275e+008	-138.4
5.2898e+008	-130.23
5.2541e+008	-122.06
5.2202e+008	-113.89
5.188e+008	-105.72
5.1571e+008	-97.544
5.1274e+008	-89.372
5.0986e+008	-81.201
5.0704e+008	-73.029
5.0427e+008	-64.857
5.0151e+008	-56.685
4.9876e+008	-48.514
4.9597e+008	-40.342
4.9313e+008	-32.17
4.9022e+008	-23.998
4.8721e+008	-15.827
4.8407e+008	-7.6551
4.8079e+008	0.51667
4.7735e+008	8.6884
4.737e+008	16.86
4.6985e+008	25.032
4.6575e+008	33.204
4.6138e+008	41.375
4.5673e+008	49.547
4.5177e+008	57.719
4.4648e+008	65.89
4.4082e+008	74.062
4.3479e+008	82.234
4.2835e+008	90.406
4.2148e+008	98.577
3.8152e+008	106.75
3.3689e+008	114.92
2.9467e+008	123.09
2.5601e+008	131.26
2.2171e+008	139.44
1.9223e+008	147.61

1.6771e+008	155.78
1.4794e+008	163.95
1.324e+008	172.12
1.2022e+008	180.29
1.1018e+008	188.47
1.0141e+008	196.64
9.3918e+007	204.81
8.7157e+007	212.98
8.1071e+007	221.15
7.5603e+007	229.32
7.07e+007	237.5
6.631e+007	245.67
6.2384e+007	253.84
5.8876e+007	262.01
5.574e+007	270.18
5.2935e+007	278.36
5.042e+007	286.53
4.8157e+007	294.7
4.611e+007	302.87
4.4247e+007	311.04
4.2537e+007	319.21
4.095e+007	327.39
3.946e+007	335.56
3.8043e+007	343.73
3.6676e+007	351.9
3.5341e+007	360.07
3.4019e+007	368.24
3.2695e+007	376.42
3.1357e+007	384.59
2.9994e+007	392.76
2.8597e+007	400.93
2.716e+007	409.1
2.568e+007	417.27
2.4154e+007	425.45
2.2584e+007	433.62
2.0972e+007	441.79
1.9324e+007	449.96
1.7646e+007	458.13
1.595e+007	466.3
1.4245e+007	474.48
1.2548e+007	482.65
1.0874e+007	490.82
9.2425e+006	498.99
7.674e+006	507.16
6.192e+006	515.33
4.8221e+006	523.51
3.5922e+006	531.68
2.5322e+006	539.85

TABLE 19
7075 (UNS A97075) > Tensile Ultimate Strength

Tensile Ultimate Strength Pa	Temperature C
7.65e+008	-269.15
7.6245e+008	-260.98
7.5936e+008	-252.81
7.4368e+008	-244.63
7.29e+008	-236.46
7.1529e+008	-228.29
7.0251e+008	-220.12
6.906e+008	-211.95
6.7953e+008	-203.78
6.6925e+008	-195.6
6.5973e+008	-187.43
6.5093e+008	-179.26
6.4279e+008	-171.09
6.3528e+008	-162.92
6.2836e+008	-154.75
6.2198e+008	-146.57
6.1611e+008	-138.4
6.107e+008	-130.23
6.057e+008	-122.06
6.0109e+008	-113.89
5.9681e+008	-105.72
5.9283e+008	-97.544
5.8909e+008	-89.372
5.8557e+008	-81.201
5.8221e+008	-73.029
5.7899e+008	-64.857
5.7584e+008	-56.685
5.7274e+008	-48.514
5.6964e+008	-40.342
5.665e+008	-32.17
5.6328e+008	-23.998
5.5993e+008	-15.827
5.5642e+008	-7.6551
5.527e+008	0.51667
5.4873e+008	8.6884
5.4446e+008	16.86
5.3986e+008	25.032
5.3489e+008	33.204
5.295e+008	41.375
5.2365e+008	49.547
5.173e+008	57.719
5.104e+008	65.89
5.0293e+008	74.062
4.9482e+008	82.234
4.8605e+008	90.406
4.7656e+008	98.577

4.3469e+008	106.75
3.871e+008	114.92
3.4111e+008	123.09
2.9795e+008	131.26
2.5859e+008	139.44
2.2374e+008	147.61
1.9383e+008	155.78
1.6904e+008	163.95
1.4931e+008	172.12
1.3428e+008	180.29
1.2335e+008	188.47
1.1565e+008	196.64
1.0933e+008	204.81
1.03e+008	212.98
9.7132e+007	221.15
9.1691e+007	229.32
8.6652e+007	237.5
8.1988e+007	245.67
7.7674e+007	253.84
7.3684e+007	262.01
6.9995e+007	270.18
6.6583e+007	278.36
6.3426e+007	286.53
6.0502e+007	294.7
5.779e+007	302.87
5.527e+007	311.04
5.2923e+007	319.21
5.073e+007	327.39
4.8674e+007	335.56
4.6738e+007	343.73
4.4905e+007	351.9
4.3161e+007	360.07
4.149e+007	368.24
3.9879e+007	376.42
3.8316e+007	384.59
3.6787e+007	392.76
3.5282e+007	400.93
3.3791e+007	409.1
3.2302e+007	417.27
3.0808e+007	425.45
2.9301e+007	433.62
2.7772e+007	441.79
2.6215e+007	449.96
2.4625e+007	458.13
2.2997e+007	466.3
2.1326e+007	474.48
1.961e+007	482.65
1.7845e+007	490.82

1.6029e+007	498.99
1.4162e+007	507.16
1.2244e+007	515.33
1.0275e+007	523.51
8.2565e+006	531.68
6.1907e+006	539.85

TABLE 20
7075 (UNS A97075) > Isotropic Secant Coefficient of Thermal Expansion

Coefficient of Thermal Expansion C ⁻¹	Temperature C
1.4225e-005	-273.15
1.4583e-005	-266.08
1.494e-005	-259.01
1.5309e-005	-251.94
1.5736e-005	-244.87
1.6143e-005	-237.8
1.6531e-005	-230.73
1.6902e-005	-223.66
1.7254e-005	-216.58
1.759e-005	-209.51
1.7909e-005	-202.44
1.8213e-005	-195.37
1.8501e-005	-188.3
1.8775e-005	-181.23
1.9035e-005	-174.16
1.9281e-005	-167.09
1.9514e-005	-160.02
1.9735e-005	-152.95
1.9944e-005	-145.88
2.0142e-005	-138.81
2.0329e-005	-131.74
2.0506e-005	-124.67
2.0673e-005	-117.59
2.083e-005	-110.52
2.0978e-005	-103.45
2.1118e-005	-96.382
2.125e-005	-89.312
2.1375e-005	-82.241
2.1492e-005	-75.17
2.1603e-005	-68.099
2.1707e-005	-61.029
2.1805e-005	-53.958
2.1898e-005	-46.887
2.1985e-005	-39.817
2.2068e-005	-32.746
2.2146e-005	-25.675
2.222e-005	-18.605
2.229e-005	-11.534
2.2357e-005	-4.4631

2.2421e-005	2.6076
2.2482e-005	9.6783
2.254e-005	16.749
2.2596e-005	23.82
2.265e-005	30.89
2.2702e-005	37.961
2.2753e-005	45.032
2.2803e-005	52.103
2.2851e-005	59.173
2.2899e-005	66.244
2.2946e-005	73.315
2.2993e-005	80.385
2.304e-005	87.456
2.3086e-005	94.527
2.3133e-005	101.6
2.318e-005	108.67
2.3227e-005	115.74
2.3276e-005	122.81
2.3325e-005	129.88
2.3374e-005	136.95
2.3425e-005	144.02
2.3477e-005	151.09
2.353e-005	158.16
2.3584e-005	165.23
2.364e-005	172.3
2.3697e-005	179.38
2.3755e-005	186.45
2.3815e-005	193.52
2.3876e-005	200.59
2.3939e-005	207.66
2.4003e-005	214.73
2.4069e-005	221.8
2.4136e-005	228.87
2.4205e-005	235.94
2.4275e-005	243.01
2.4347e-005	250.08
2.442e-005	257.15
2.4494e-005	264.22
2.4569e-005	271.29
2.4646e-005	278.37
2.4724e-005	285.44
2.4802e-005	292.51
2.4882e-005	299.58
2.4962e-005	306.65
2.5042e-005	313.72
2.5124e-005	320.79
2.5205e-005	327.86
2.5286e-005	334.93

2.5368e-005	342
2.5449e-005	349.07
2.5529e-005	356.14
2.5609e-005	363.21
2.5688e-005	370.28
2.5766e-005	377.36
2.5843e-005	384.43
2.5918e-005	391.5
2.5991e-005	398.57
2.6062e-005	405.64
2.6131e-005	412.71
2.6197e-005	419.78
2.626e-005	426.85
Reference Temperature C	
19.85	

TABLE 21
7075 (UNS A97075) > Specific Heat

Specific Heat J kg ⁻¹ C ⁻¹	Temperature C
572.12	-157.15
586.75	-151.25
600.86	-145.35
614.47	-139.45
627.58	-133.55
640.21	-127.66
652.39	-121.76
664.12	-115.86
675.41	-109.96
686.29	-104.06
696.77	-98.16
706.86	-92.261
716.57	-86.362
725.92	-80.463
734.93	-74.564
743.6	-68.665
751.94	-62.766
759.98	-56.867
767.73	-50.968
775.18	-45.069
782.37	-39.17
789.3	-33.271
795.98	-27.372
802.42	-21.473
808.64	-15.574
814.64	-9.6753
820.44	-3.7763
826.05	2.1227
831.48	8.0217
836.74	13.921

841.83	19.82
846.78	25.719
851.58	31.618
856.25	37.517
860.8	43.416
865.23	49.315
869.56	55.214
873.8	61.113
877.95	67.012
882.01	72.911
886.01	78.81
889.94	84.709
893.82	90.608
897.65	96.507
901.44	102.41
905.2	108.3
908.92	114.2
912.63	120.1
916.33	126
920.01	131.9
923.7	137.8
927.39	143.7
931.09	149.6
934.8	155.5
938.53	161.4
942.29	167.29
946.08	173.19
949.91	179.09
953.77	184.99
957.68	190.89
961.64	196.79
965.64	202.69
969.7	208.59
973.82	214.49
978	220.39
982.25	226.28
986.56	232.18
990.94	238.08
995.39	243.98
999.91	249.88
1004.5	255.78
1009.2	261.68
1014	267.58
1018.8	273.48
1023.7	279.38
1028.7	285.27
1033.8	291.17
1039	297.07

1044.2	302.97
1049.5	308.87
1055	314.77
1060.5	320.67
1066	326.57
1071.7	332.47
1077.5	338.37
1083.3	344.26
1089.2	350.16
1095.2	356.06
1101.2	361.96
1107.4	367.86
1113.6	373.76
1119.8	379.66
1126.2	385.56
1132.5	391.46
1139	397.36
1145.5	403.25
1152.1	409.15
1158.7	415.05
1165.4	420.95
1172.1	426.85

TABLE 22
7075 (UNS A97075) > Isotropic Thermal Conductivity

Thermal Conductivity W m ⁻¹ C ⁻¹	Temperature C
77.555	-157.15
79.962	-151.25
82.281	-145.35
84.514	-139.45
86.664	-133.55
88.735	-127.66
90.73	-121.76
92.651	-115.86
94.501	-109.96
96.284	-104.06
98.002	-98.16
99.659	-92.261
101.26	-86.362
102.8	-80.463
104.29	-74.564
105.73	-68.665
107.13	-62.766
108.48	-56.867
109.79	-50.968
111.06	-45.069
112.3	-39.17
113.51	-33.271
114.69	-27.372

115.84	-21.473
116.97	-15.574
118.08	-9.6753
119.18	-3.7763
120.26	2.1227
121.33	8.0217
122.4	13.921
123.46	19.82
124.51	25.719
125.57	31.618
126.64	37.517
127.71	43.416
128.79	49.315
129.89	55.214
131	61.113
132.14	67.012
133.29	72.911
134.47	78.81
135.68	84.709
136.93	90.608
138.2	96.507
139.52	102.41
140.87	108.3
142.27	114.2
143.72	120.1
145.21	126
146.76	131.9
148.36	137.8
150.03	143.7
151.75	149.6
153.54	155.5
155.39	161.4
157.32	167.29
159.32	173.19
161.4	179.09
163.56	184.99
165.8	190.89
168.13	196.79
170.54	202.69
171.5	208.59
172.09	214.49
172.65	220.39
173.17	226.28
173.64	232.18
174.08	238.08
174.48	243.98
174.84	249.88
175.17	255.78

175.45	261.68
175.69	267.58
175.9	273.48
176.06	279.38
176.19	285.27
176.28	291.17
176.33	297.07
176.34	302.97
176.31	308.87
176.24	314.77
176.13	320.67
175.99	326.57
175.8	332.47
175.58	338.37
175.32	344.26
175.01	350.16
174.67	356.06
174.29	361.96
173.87	367.86
173.41	373.76
172.92	379.66
172.38	385.56
171.8	391.46
171.19	397.36
170.54	403.25
169.84	409.15
169.11	415.05
168.34	420.95
167.53	426.85

TABLE 23
7075 (UNS A97075) > Isotropic Resistivity

Resistivity ohm m	Temperature C
2.76e-008	-269.15
2.7632e-008	-264.08
2.7665e-008	-259.01
2.7697e-008	-253.94
2.7775e-008	-248.87
2.7892e-008	-243.8
2.8042e-008	-238.73
2.8226e-008	-233.66
2.8441e-008	-228.59
2.8687e-008	-223.52
2.8963e-008	-218.45
2.9267e-008	-213.38
2.9599e-008	-208.31
2.9957e-008	-203.24
3.034e-008	-198.17
3.0747e-008	-193.1

3.1177e-008	-188.03
3.1629e-008	-182.96
3.2101e-008	-177.89
3.2593e-008	-172.82
3.3103e-008	-167.75
3.3631e-008	-162.68
3.4174e-008	-157.61
3.4733e-008	-152.54
3.5306e-008	-147.47
3.5891e-008	-142.4
3.6488e-008	-137.33
3.7095e-008	-132.26
3.7712e-008	-127.19
3.8337e-008	-122.11
3.8969e-008	-117.04
3.9607e-008	-111.97
4.025e-008	-106.9
4.0896e-008	-101.83
4.1545e-008	-96.764
4.2196e-008	-91.694
4.2847e-008	-86.624
4.3497e-008	-81.554
4.4145e-008	-76.483
4.4791e-008	-71.413
4.5432e-008	-66.343
4.6068e-008	-61.273
4.6697e-008	-56.203
4.7319e-008	-51.132
4.7932e-008	-46.062
4.8535e-008	-40.992
4.9128e-008	-35.922
4.9708e-008	-30.852
5.0275e-008	-25.782
5.0828e-008	-20.711
5.1365e-008	-15.641
5.1886e-008	-10.571
5.2389e-008	-5.5009
5.2874e-008	-0.4307
5.3338e-008	4.6395
5.3781e-008	9.7096
5.4203e-008	14.78
5.46e-008	19.85

TABLE 24
7075 (UNS A97075) > Isotropic Elasticity

Temperature C	Young's Modulus Pa	Poisson's Ratio	Bulk Modulus Pa	Shear Modulus Pa
-273.15	7.8813e+010	0.32387	7.4577e+010	2.9766e+010
-265.34	7.8818e+010	0.32391	7.46e+010	2.9767e+010
-257.53	7.88e+010	0.32398	7.4612e+010	2.9759e+010

-249.73	7.8762e+010	0.32407	7.4614e+010	2.9742e+010
-241.92	7.8704e+010	0.32418	7.4606e+010	2.9718e+010
-234.11	7.8626e+010	0.32431	7.4589e+010	2.9686e+010
-226.3	7.8532e+010	0.32446	7.4563e+010	2.9647e+010
-218.49	7.842e+010	0.32463	7.4528e+010	2.9601e+010
-210.69	7.8293e+010	0.32481	7.4485e+010	2.9549e+010
-202.88	7.8152e+010	0.32501	7.4433e+010	2.9491e+010
-195.07	7.7997e+010	0.32521	7.4374e+010	2.9428e+010
-187.26	7.7829e+010	0.32543	7.4306e+010	2.936e+010
-179.45	7.765e+010	0.32566	7.4231e+010	2.9287e+010
-171.64	7.7459e+010	0.32589	7.4148e+010	2.921e+010
-163.84	7.7259e+010	0.32613	7.4058e+010	2.9129e+010
-156.03	7.7049e+010	0.32637	7.3961e+010	2.9045e+010
-148.22	7.683e+010	0.32662	7.3857e+010	2.8957e+010
-140.41	7.6604e+010	0.32687	7.3746e+010	2.8866e+010
-132.6	7.6371e+010	0.32713	7.3629e+010	2.8773e+010
-124.8	7.6131e+010	0.32738	7.3505e+010	2.8677e+010
-116.99	7.5886e+010	0.32763	7.3376e+010	2.8579e+010
-109.18	7.5635e+010	0.32788	7.324e+010	2.848e+010
-101.37	7.538e+010	0.32813	7.3098e+010	2.8378e+010
-93.564	7.5121e+010	0.32838	7.2951e+010	2.8275e+010
-85.756	7.4858e+010	0.32862	7.2798e+010	2.8171e+010
-77.948	7.4592e+010	0.32885	7.2639e+010	2.8066e+010
-70.14	7.4324e+010	0.32908	7.2476e+010	2.796e+010
-62.332	7.4053e+010	0.32931	7.2307e+010	2.7854e+010
-54.524	7.378e+010	0.32953	7.2134e+010	2.7747e+010
-46.716	7.3506e+010	0.32974	7.1956e+010	2.7639e+010
-38.908	7.3231e+010	0.32995	7.1773e+010	2.7532e+010
-31.099	7.2955e+010	0.33014	7.1586e+010	2.7424e+010
-23.291	7.2679e+010	0.33033	7.1394e+010	2.7316e+010
-15.483	7.2402e+010	0.33052	7.1199e+010	2.7208e+010
-7.6753	7.2124e+010	0.33069	7.0999e+010	2.71e+010
0.13283	7.1847e+010	0.33086	7.0796e+010	2.6993e+010
7.9409	7.157e+010	0.33102	7.0589e+010	2.6885e+010
15.749	7.1293e+010	0.33117	7.0379e+010	2.6778e+010
23.557	7.1016e+010	0.33131	7.0166e+010	2.6671e+010
31.365	7.0739e+010	0.33145	6.995e+010	2.6565e+010
39.173	7.0463e+010	0.33158	6.973e+010	2.6458e+010
46.981	7.0187e+010	0.33171	6.9509e+010	2.6352e+010
54.789	6.9911e+010	0.33183	6.9284e+010	2.6246e+010
62.597	6.9635e+010	0.33194	6.9058e+010	2.614e+010
70.406	6.9359e+010	0.33205	6.8829e+010	2.6035e+010
78.214	6.9083e+010	0.33216	6.8598e+010	2.5929e+010
86.022	6.8806e+010	0.33226	6.8366e+010	2.5823e+010
93.83	6.8529e+010	0.33236	6.8132e+010	2.5717e+010
101.64	6.8251e+010	0.33246	6.7896e+010	2.5611e+010
109.45	6.7971e+010	0.33257	6.766e+010	2.5504e+010
117.25	6.769e+010	0.33267	6.7422e+010	2.5397e+010

125.06	6.7407e+010	0.33278	6.7183e+010	2.5288e+010
132.87	6.7122e+010	0.33289	6.6944e+010	2.5179e+010
140.68	6.6834e+010	0.33301	6.6704e+010	2.5069e+010
148.49	6.6543e+010	0.33313	6.6464e+010	2.4958e+010
156.29	6.6249e+010	0.33327	6.6223e+010	2.4844e+010
164.1	6.595e+010	0.33342	6.5982e+010	2.473e+010
171.91	6.5646e+010	0.33358	6.5742e+010	2.4613e+010
179.72	6.5338e+010	0.33375	6.5502e+010	2.4494e+010
187.53	6.5023e+010	0.33394	6.5262e+010	2.4372e+010
195.33	6.4702e+010	0.33416	6.5022e+010	2.4248e+010
203.14	6.4373e+010	0.33439	6.4784e+010	2.4121e+010
210.95	6.4037e+010	0.33465	6.4546e+010	2.399e+010
218.76	6.3692e+010	0.33493	6.4309e+010	2.3856e+010
226.57	6.3337e+010	0.33525	6.4073e+010	2.3717e+010
234.38	6.2972e+010	0.33559	6.3839e+010	2.3575e+010
242.18	6.2596e+010	0.33598	6.3605e+010	2.3427e+010
249.99	6.2209e+010	0.3364	6.3374e+010	2.3275e+010
257.8	6.1808e+010	0.33686	6.3143e+010	2.3117e+010
265.61	6.1394e+010	0.33736	6.2915e+010	2.2953e+010
273.42	6.0964e+010	0.33792	6.2688e+010	2.2783e+010
281.22	6.0519e+010	0.33852	6.2463e+010	2.2607e+010
289.03	6.0058e+010	0.33918	6.224e+010	2.2423e+010
296.84	5.9578e+010	0.33989	6.202e+010	2.2232e+010
304.65	5.908e+010	0.34067	6.1801e+010	2.2034e+010
312.46	5.8561e+010	0.34152	6.1585e+010	2.1826e+010
320.26	5.8021e+010	0.34243	6.1371e+010	2.161e+010
328.07	5.7459e+010	0.34342	6.1159e+010	2.1385e+010
335.88	5.6873e+010	0.34448	6.095e+010	2.1151e+010
343.69	5.6262e+010	0.34563	6.0744e+010	2.0906e+010
351.5	5.5625e+010	0.34687	6.0541e+010	2.065e+010
359.3	5.4961e+010	0.34819	6.034e+010	2.0383e+010
367.11	5.4268e+010	0.34961	6.0143e+010	2.0105e+010
374.92	5.3544e+010	0.35114	5.9948e+010	1.9815e+010
382.73	5.2789e+010	0.35277	5.9757e+010	1.9512e+010
390.54	5.2001e+010	0.35451	5.9569e+010	1.9196e+010
398.34	5.1178e+010	0.35636	5.9384e+010	1.8866e+010
406.15	5.0319e+010	0.35834	5.9203e+010	1.8522e+010
413.96	4.9423e+010	0.36045	5.9026e+010	1.8164e+010
421.77	4.8487e+010	0.36269	5.8853e+010	1.7791e+010
429.58	4.7511e+010	0.36507	5.8684e+010	1.7402e+010
437.39	4.6492e+010	0.36759	5.8519e+010	1.6998e+010
445.19	4.5429e+010	0.37026	5.8359e+010	1.6577e+010
453	4.432e+010	0.37309	5.8204e+010	1.6139e+010
460.81	4.3164e+010	0.37608	5.8054e+010	1.5683e+010
468.62	4.1958e+010	0.37925	5.7911e+010	1.521e+010
476.43	4.0701e+010	0.38258	5.7773e+010	1.4719e+010
484.23	3.9391e+010	0.38611	5.7643e+010	1.4209e+010
492.04	3.8027e+010	0.38982	5.7521e+010	1.368e+010

499.85	3.6605e+010	0.39373	5.7407e+010	1.3132e+010
--------	-------------	---------	-------------	-------------

TABLE 25
7075 (UNS A97075) > Multilinear Isotropic Hardening

Stress Pa	Plastic Strain m m ⁻¹	Temperature C
4.9711e+008	0	19.85
5.1103e+008	5.7895e-003	19.85
5.233e+008	1.1579e-002	19.85
5.3415e+008	1.7368e-002	19.85
5.4377e+008	2.3158e-002	19.85
5.5236e+008	2.8947e-002	19.85
5.6009e+008	3.4737e-002	19.85
5.6711e+008	4.0526e-002	19.85
5.7356e+008	4.6316e-002	19.85
5.7956e+008	5.2105e-002	19.85
5.8521e+008	5.7895e-002	19.85
5.9061e+008	6.3684e-002	19.85
5.9582e+008	6.9474e-002	19.85
6.009e+008	7.5263e-002	19.85
6.0589e+008	8.1053e-002	19.85
6.1081e+008	8.6842e-002	19.85
6.1566e+008	9.2632e-002	19.85
6.2043e+008	9.8421e-002	19.85
6.2509e+008	0.10421	19.85
6.296e+008	0.11	19.85

TABLE 26
7075 (UNS A97075) > Alternating Stress R-Ratio

Alternating Stress Pa	Cycles	R-Ratio
3.4779e+008	4000	-1
3.4027e+008	4677.6	-1
3.3275e+008	5469.9	-1
3.252e+008	6396.4	-1
3.1762e+008	7479.9	-1
3.1e+008	8746.9	-1
3.0236e+008	10229	-1
2.9467e+008	11961	-1
2.8696e+008	13987	-1
2.7923e+008	16356	-1
2.7148e+008	19127	-1
2.6373e+008	22367	-1
2.5599e+008	26156	-1
2.4828e+008	30586	-1
2.406e+008	35767	-1
2.3297e+008	41826	-1
2.2542e+008	48910	-1
2.1796e+008	57195	-1
2.1061e+008	66883	-1
2.0338e+008	78213	-1

1.963e+008	91461	-1
1.8939e+008	1.0695e+005	-1
1.8266e+008	1.2507e+005	-1
1.7614e+008	1.4626e+005	-1
1.6983e+008	1.7103e+005	-1
1.6377e+008	2.e+005	-1
1.5796e+008	2.3388e+005	-1
1.5243e+008	2.7349e+005	-1
1.4717e+008	3.1982e+005	-1
1.4222e+008	3.7399e+005	-1
1.3757e+008	4.3734e+005	-1
1.3324e+008	5.1143e+005	-1
1.2923e+008	5.9806e+005	-1
1.2555e+008	6.9936e+005	-1
1.222e+008	8.1782e+005	-1
1.1918e+008	9.5635e+005	-1
1.1648e+008	1.1183e+006	-1
1.141e+008	1.3078e+006	-1
1.1202e+008	1.5293e+006	-1
1.1024e+008	1.7884e+006	-1
1.0874e+008	2.0913e+006	-1
1.0749e+008	2.4455e+006	-1
1.0647e+008	2.8598e+006	-1
1.0566e+008	3.3442e+006	-1
1.0501e+008	3.9106e+006	-1
1.0449e+008	4.5731e+006	-1
1.0406e+008	5.3477e+006	-1
1.0366e+008	6.2535e+006	-1
1.0325e+008	7.3128e+006	-1
1.0215e+008	1.e+007	-1