

R 0.125 Fillet

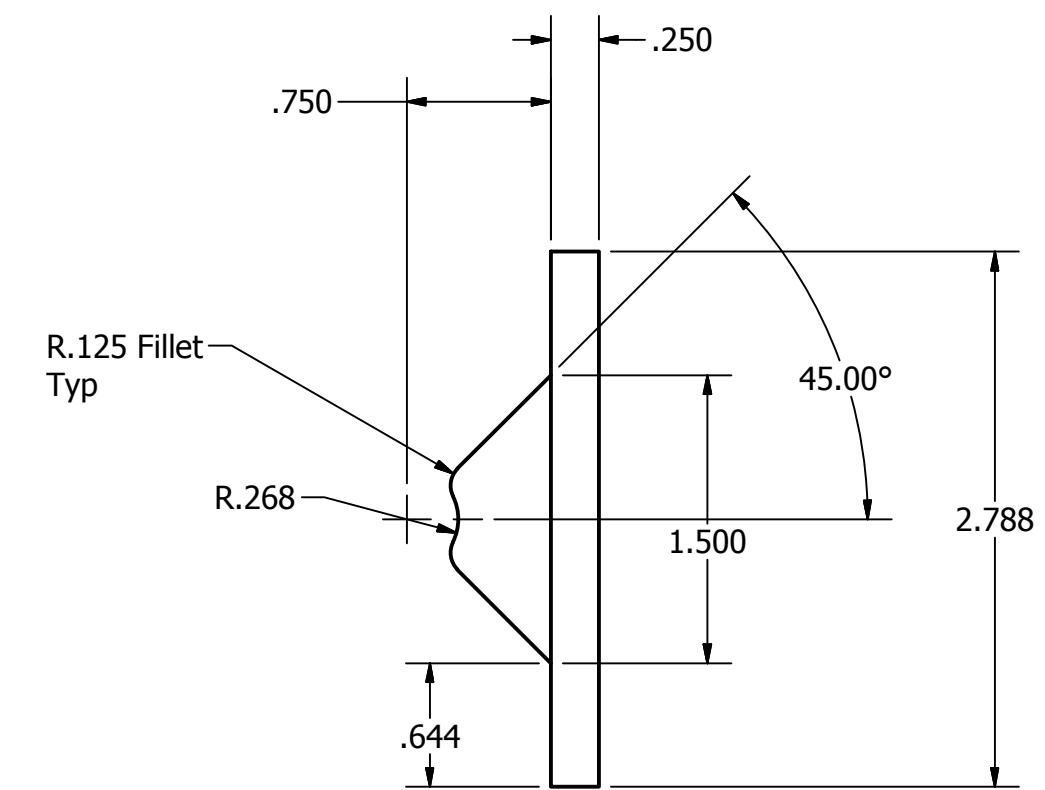
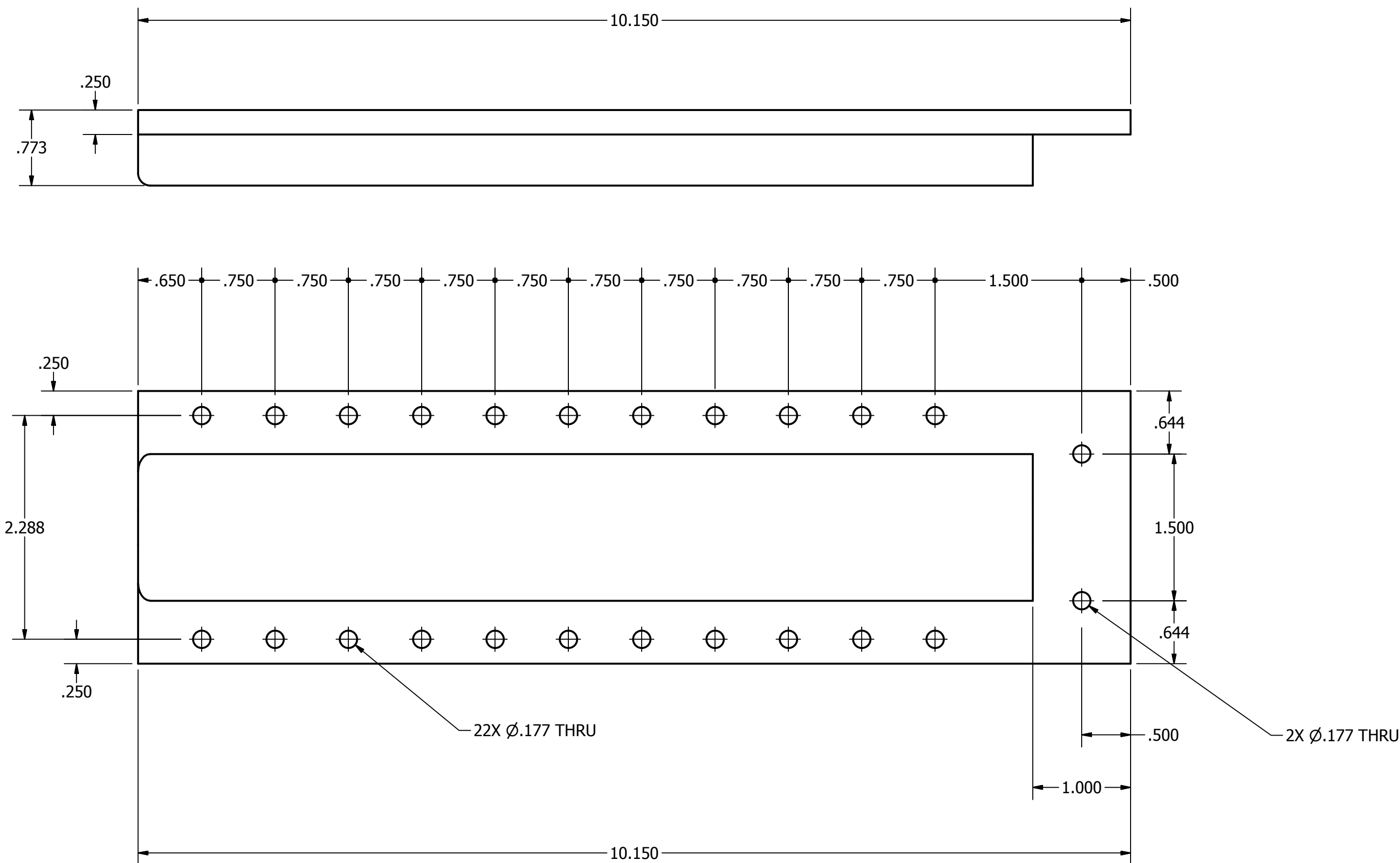

DOCUMENT CONTROL STAMP		DIM & TOL PER ASME Y14.5 - UNLESS OTHERWISE SPECIFIED DIMENSIONS ARE IN INCHES TOLERANCES ARE: FRACTIONS ±1/64 DECIMAL .XX±0.01 ANGLE ±0.5° .XXX±0.005	APPROVALS	DATE	JEFFERSON LAB TARGET GROUP THOMAS JEFFERSON NATIONAL ACCELERATOR FACILITY NEWPORT NEWS VIRGINIA U.S. DEPARTMENT OF ENERGY
MATERIAL ASTM B209 AL 7075-T651			DRAWN D. Meekins	11/17/2014	
FINISH 32 UNLESS OTHERWISE NOTED DEBUR AND BREAK ALL SHARP EDGES ACCEPT AS NOTED		THIRD ANGLE PROJECTION			Hall A Tritium Target Target Cell Shipping and Filling Side Cover
Do Not Scale Drawing					
				SIZE D DWG NO TGT-103-1000-0110 SCALE 1:1	ASSY. NO. REV - SHEET 1 OF 1