

DETAIL B
SCALE 4 : 1

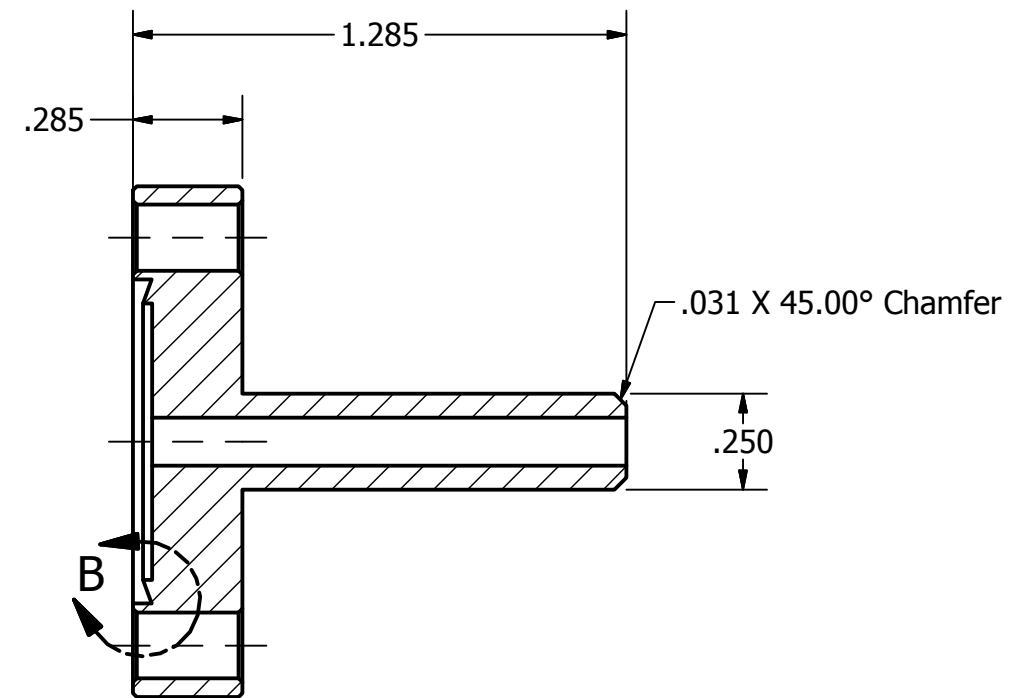
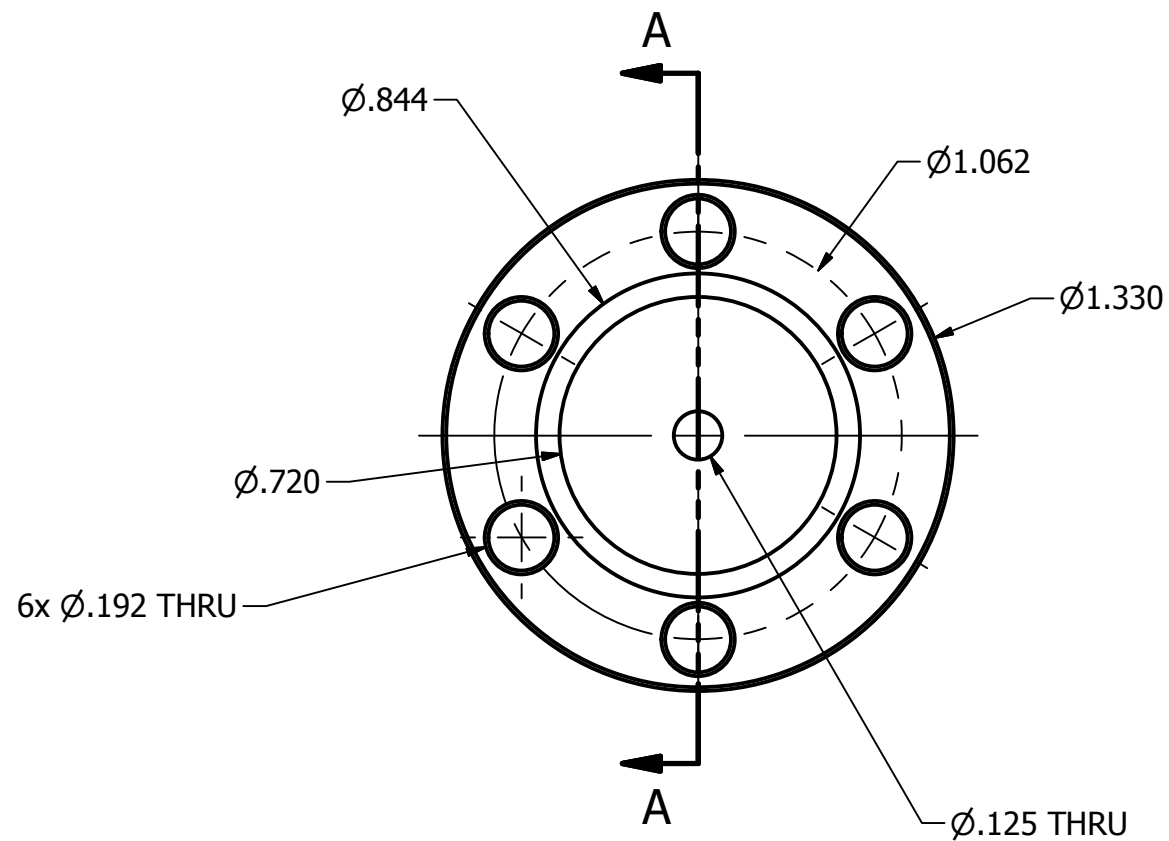

SECTION A-A
SCALE 2 : 1

NOTE:
TO BE MADE FROM ASTM A240 PLATE ONLY
CMTR REQUIRED

DOCUMENT CONTROL STAMP	DIM & TOL PER ASME Y14.5 . UNLESS OTHERWISE SPECIFIED DIMENSIONS ARE IN INCHES TOLERANCES ARE: FRACTIONS DECIMAL ANGLE $\pm 1/64$ $.X \pm 0.1$ $\pm 0.5'$ $.XX \pm 0.01$ $.XXX \pm 0.005$	APPROVALS	DATE	JEFFERSON LAB TARGET GROUP THOMAS JEFFERSON NATIONAL ACCELERATOR FACILITY NEWPORT NEWS VIRGINIA U.S. DEPARTMENT OF ENERGY		
MATERIAL SST ASTM A240 316/316L		DRAWN D. Meekins	12/9/2011			
FINISH DEBUR AND BREAK ALL SHARP EDGES ACCEPT AS NOTED	THIRD ANGLE PROJECTION	CHECKED		Hall A Tritium Target Tritium Cell Mini CF 1.33 Special		
Do Not Scale Drawing		APPROVED				
		APPROVED		SIZE B	DWG NO TGT-103-1000-0105	REV -
		APPROVED		SCALE 2:1	ASSY. NO.	SHEET 1 OF 1