

# CEBAF Photo-injector Drive Laser for K-Long Beam

## Outline

- K-Long Experiment Requirements
- CEBAF Photo-injector Laser system
- Laser for K-Long Experiment
- Cost & Schedule

S. Zhang

Friday, May 27, 2022

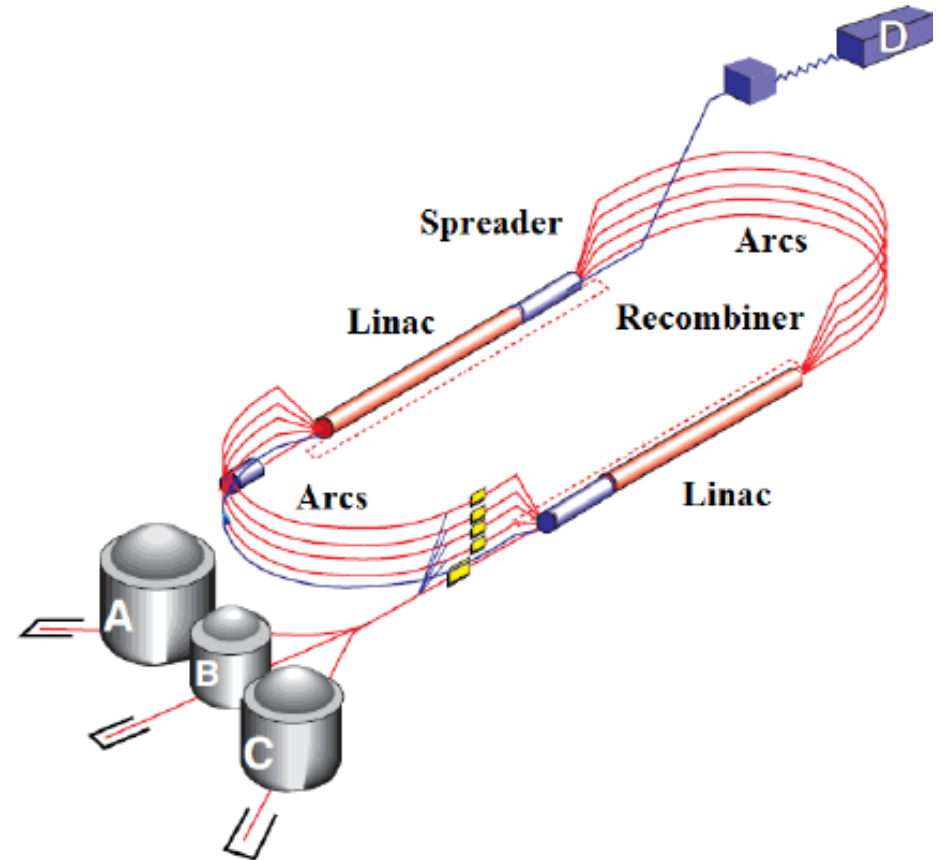

# K-Long Experiment Requirements

- M. Anaryan, *PAC48, JLab, August 11, 2020*  
 Beam Energy 12GeV, 5uA, bunch spacing 64~128ns  
**To accomplish physics program, 100 days per LH2 and LD2 is required**
- Different interpretation of **2 key parameters**

By S. Pokharel

Current (μA)	Rep Rate (MHz)	Sub-harmonic of 499 MHz	Bunch Charge (pC)	Equivalent 249.5 MHz current (μA)
2.5	15.59 (64 ns)	32 <sup>nd</sup>	0.16	40
2.5	7.80 (128 ns)	64 <sup>th</sup>	0.32	80
5.0	15.59	32 <sup>nd</sup>	0.32	80
5.0	7.80	64 <sup>th</sup>	0.64	160

- Questions:  
 Among other things,
  - Would the existing lasers work for KL experiment?
  - Solution if not?

# Latest Beam Test

- Message

Beam transmission and interceptions are recorded for 250 MHz CW beam using **C Laser**. The beam interceptions are high than the previous measurements for high bunch charge ( for high current). We increase the current *from 5 muA to 160 muA* in steps of 5 muA. Again we did the Chopper slit scan for measuring the bunch length with prebuncher off and on for high charge and low charge.

(Log# [3995520](#). [Fri, 05/20/2022 - 06:37](#))

Just a general comment about last night. 200 muA at 249.5 MHz is 0.8 pC charge.

The *K Long requirement is 0.64 pC. So one might claim we can do that!*

Need to be a bit cautious about claiming "victory" yet because there is significant aperture loss at the present settings. In addition to the steering optimization Alicia did, we explored changing the upstream solenoid. Found the settings at 100 muA transmitted current (about 130 muA out of gun) had equal loss on the two apertures. Changing the solenoid changes the aperture where the loss occurs, but doesn't have much effect on the total losses. *The >100 muA data recorded last evening have significant aperture losses.*

# CEBAF Photo-Gun Drive Laser System

- 1.5um Gain-switched seed
- MOPO+SHG
- Polarization/Helicity control
- 499/249MHz CW
- TMD for low duty cycle beam
- 30~50ps pulse
- 780nm/SHG
- mW~100s mW
- 4 independent lasers to 4 Halls (A, B, C, D)

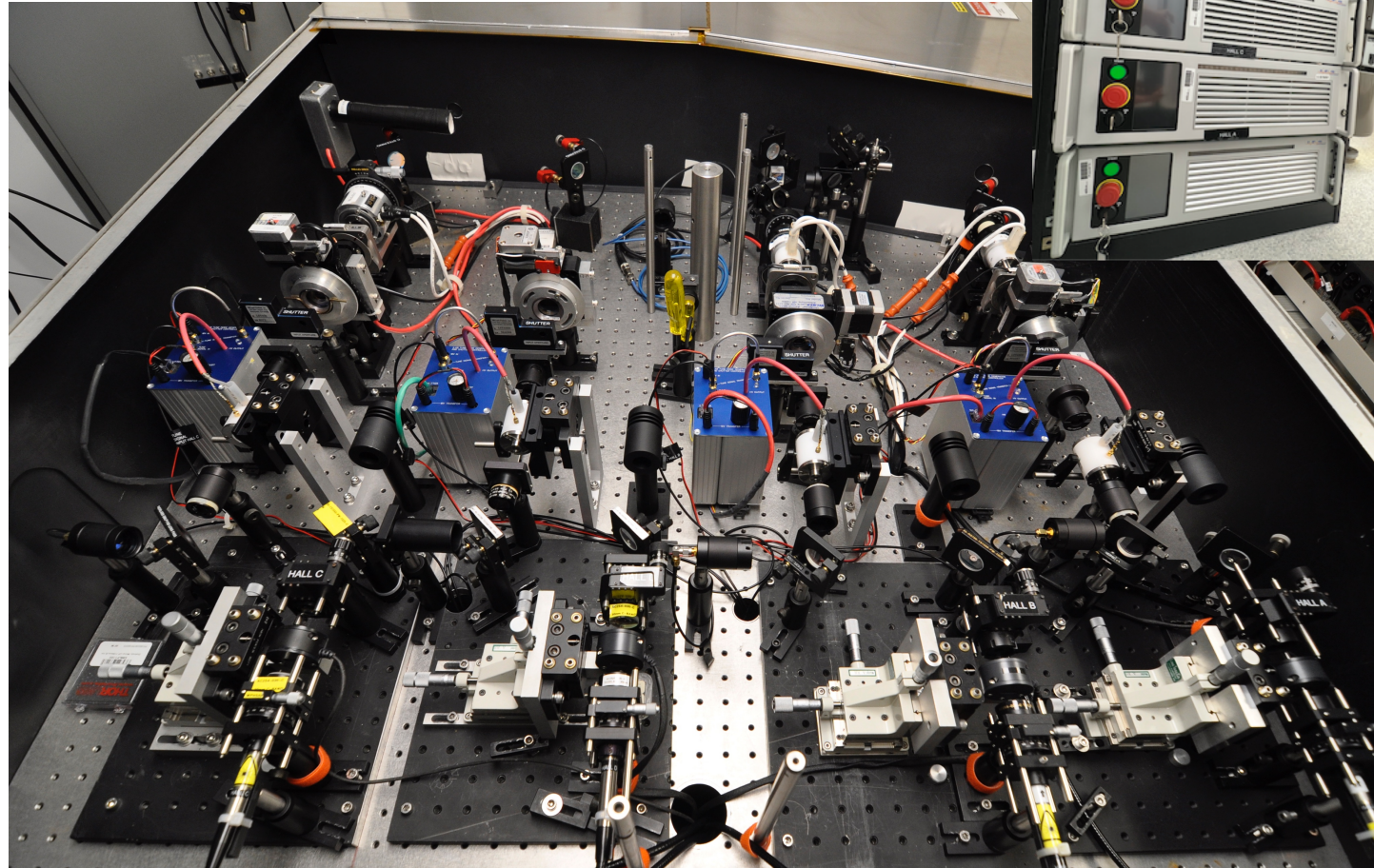

- Relatively low pulse energy
- Not suitable for low rep-rate, high pulse energy operation.

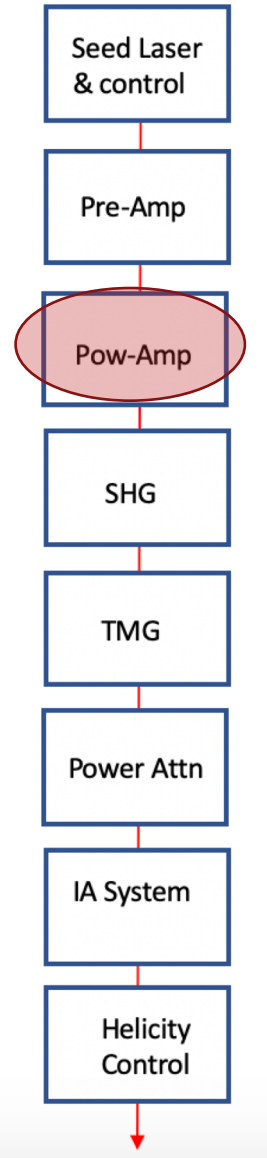



# Photo-Cathode

- SSL GaAs
- QE 0.5~1%,
- Pol >85%

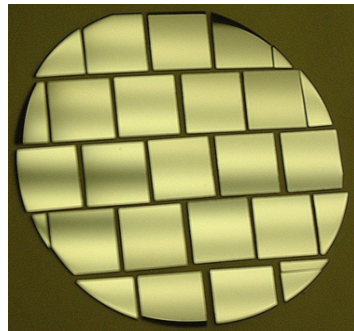
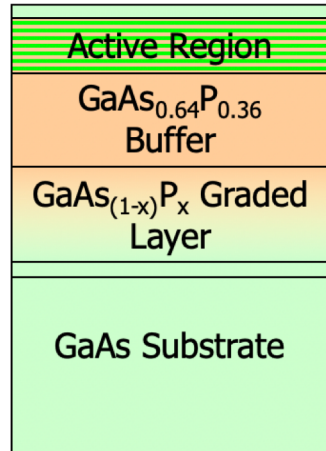

05/20/2022 – before KL test, Log# 3995474

Laser	Wavelength (nm)	Atten Setting	Laser Power (W)	Current (uA)	HV PS Current	QE %
Hall A	780.000	190	0.00422	12.3443	12.4683	0.4646
Hall B	780.000	460	0.00312	9.1503	9.5015	0.4665
Hall C	780.000	155	0.00344	10.6673	10.9046	0.4934
Hall D	780.000	325	0.00341	10.1928	10.4779	0.4754

05/20/2022 – after KL test, Log# 3995519

Laser	Wavelength (nm)	Atten Setting	Laser Power (W)	Current (uA)	HV PS Current	QE %
Hall A	780.000	190	0.00424	12.2111	12.3405	0.4575
Hall B	780.000	480	0.00352	10.2236	10.5582	0.4622
Hall C	780.000	155	0.00322	10.5509	10.8795	0.5217
Hall D	780.000	325	0.00363	10.8147	11.1613	0.4734

# Photo-Cathode

- Limited life time, QE depletion, Cathode degradation/damage, etc.

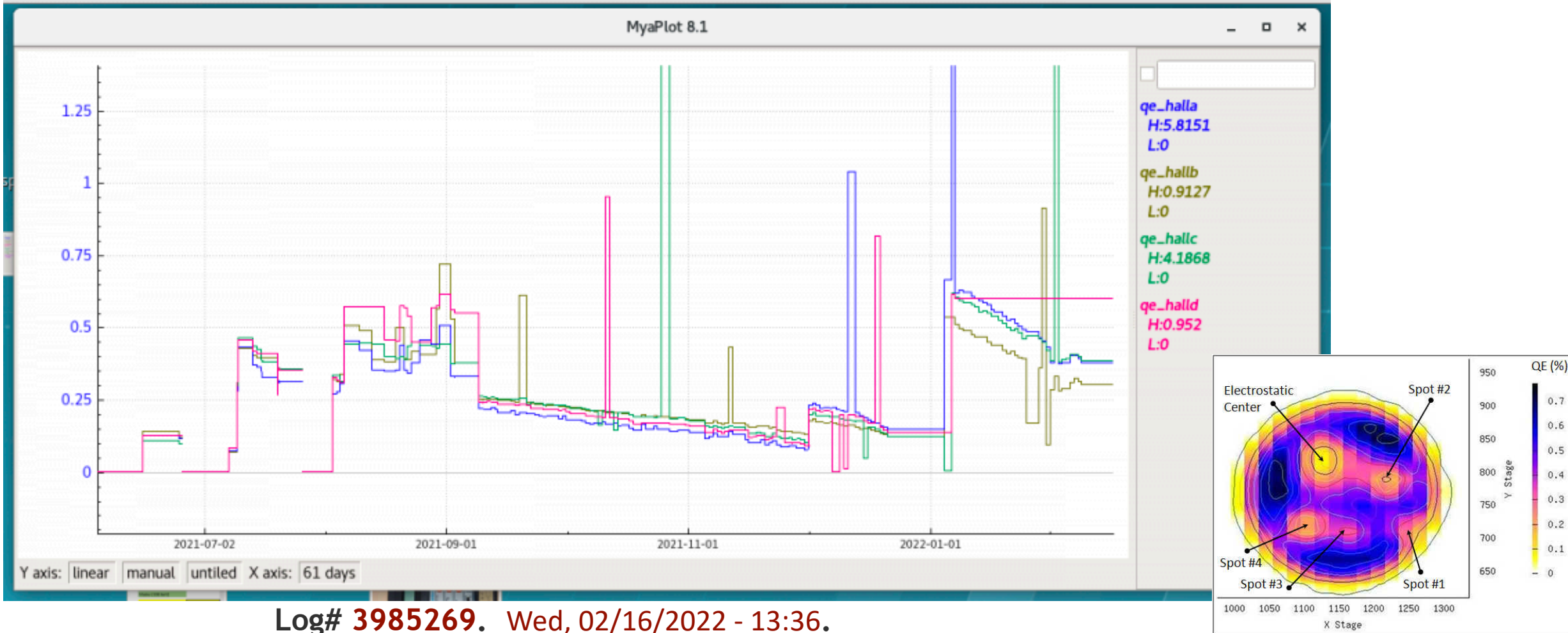

# CEBAF PhotoGun Cathode

- Limited life time, QE depletion, Cathode degradation/damage, etc.

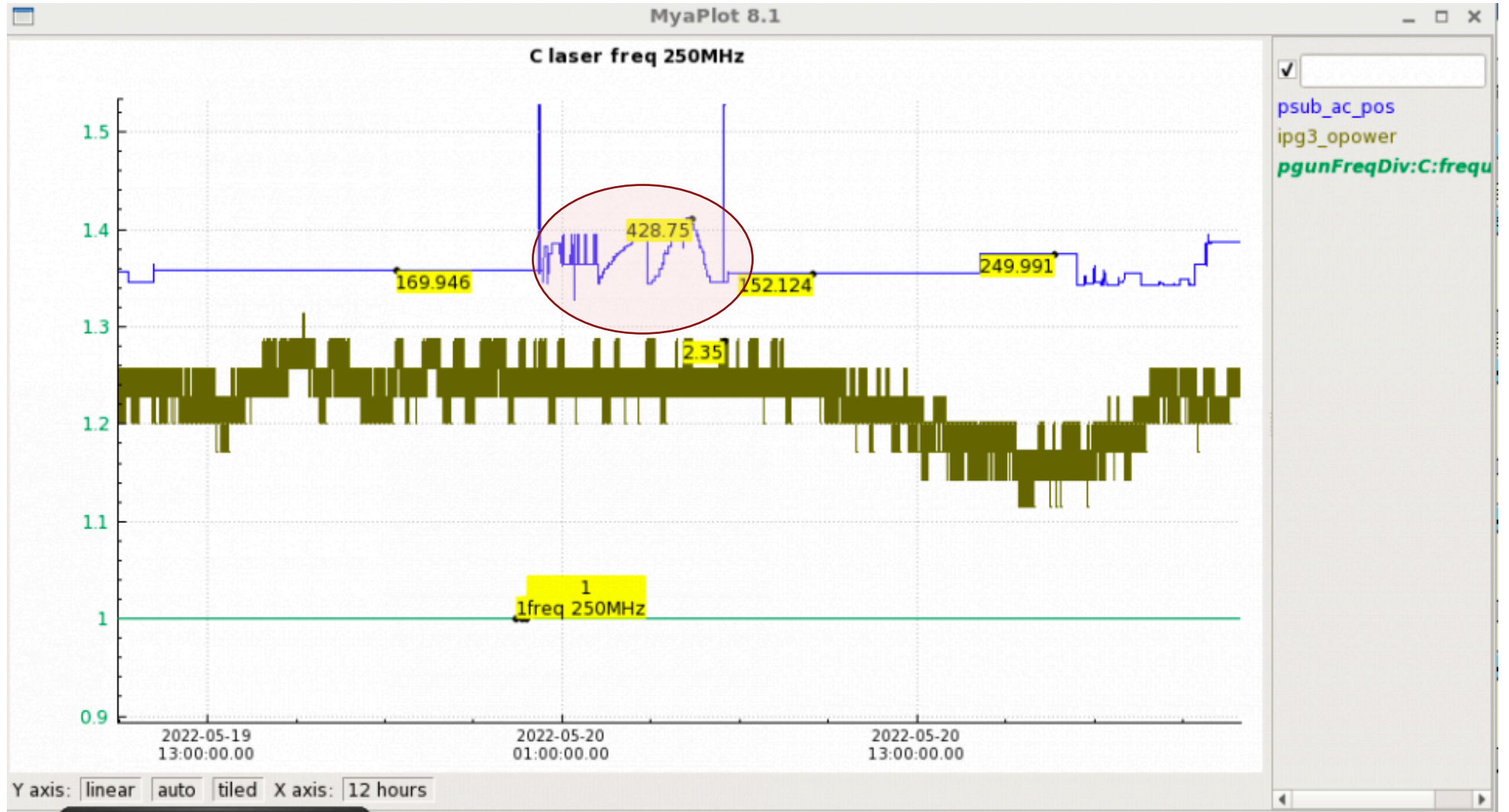

# An Example of Low Rep-rate Operation

- Bubble chamber exp in Oct. 2015

**Hall B laser @ 31 MHz. Log# 3354307.**

Hall B laser for 31 MHz operation. We can generate  $\sim 18\mu\text{A}$  @ 31 MHz w/ maximum output power of 2.67 mW consistent with an expected QE of  $\sim 1.1\%$ . This corresponds a bunch charge equivalent of  $288\mu\text{A}$  @ 499 MHz, thus we expect we can operate without too much effort up to  $\sim 5\mu\text{A}$  @ 31 MHz which is sufficient for the Mott Run II program next weekend.

**At initial setup, the laser power amplifier was damaged due to low rep rate/higher pulse energy!**

- Lower QE, lower rep-rate, requires higher pulse energy, means higher risk of damage!
- The existing power amplifiers are designed for DC or high rep-rate CW beam
- A new amplifier that can tolerate high pulse energy would be the key element for a long-time worry-free operation



# 1.5um High Pulse Energy Fiber Laser Amplifier

- For input signal (customer seed laser pulses):  
wavelength 1.5  $\mu\text{m}$ ,  
average power  $>1$  mW  
Pulse length 30~50 ps
- Average power  $>10$  W  
Pulse energy  $> 1\mu\text{J}$   
Pulse rate  $>1$  MHz  
Linear polarization  
Output beam: free-space, collimated
- Package: [amplifier module + control unit], turn-key system

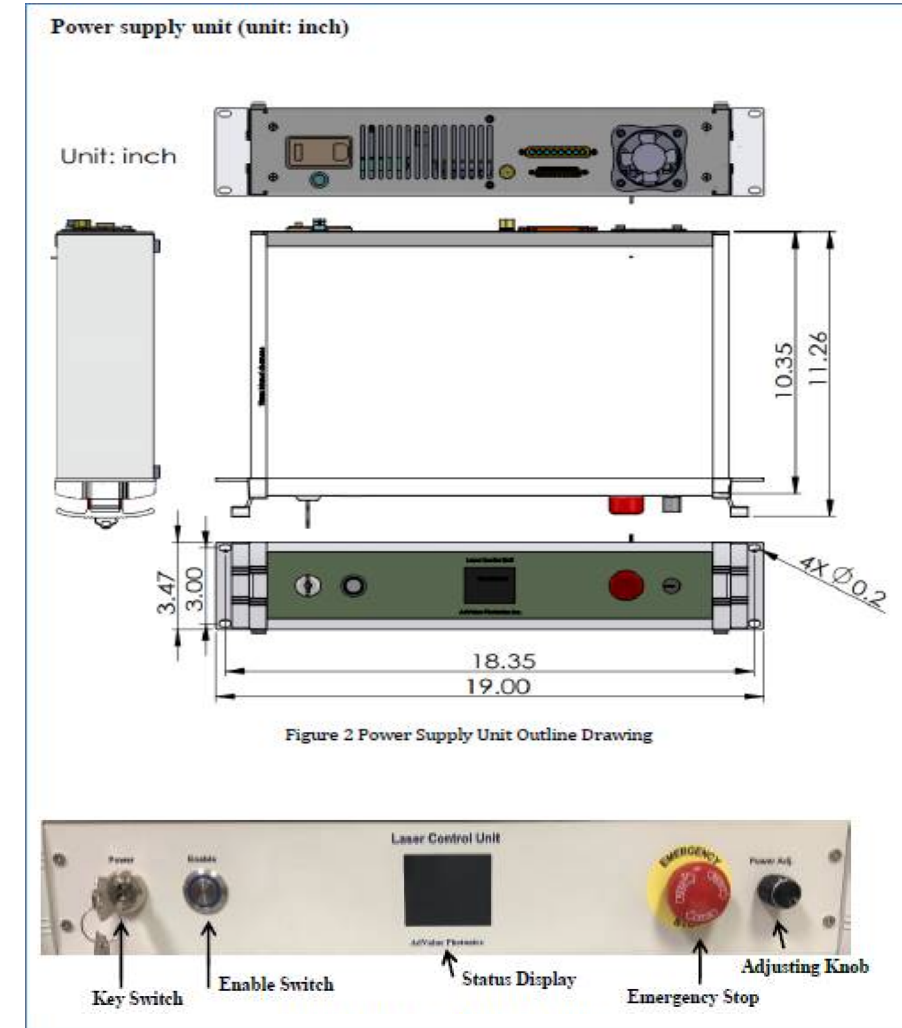
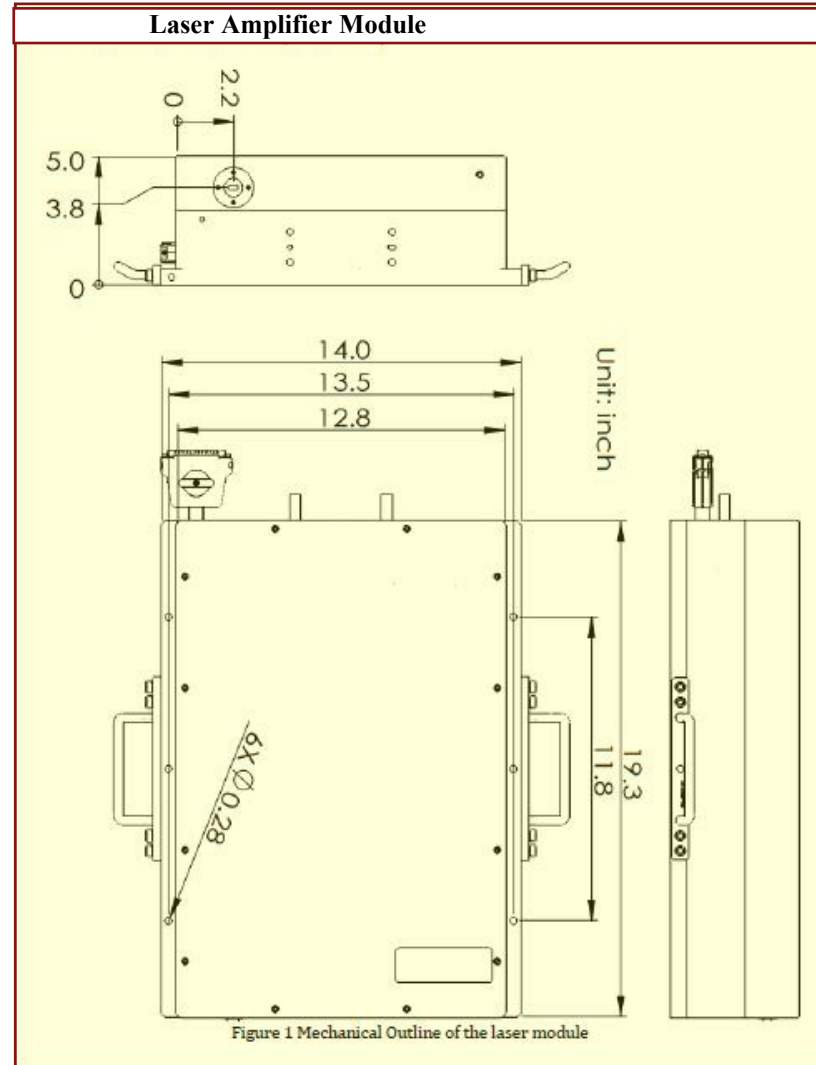

# Integration into the Drive Laser System

- Replace the existing power amplifier (D)
- Use the existing seed laser & the section downstream of the D laser
- Additional optics needed to match the specs

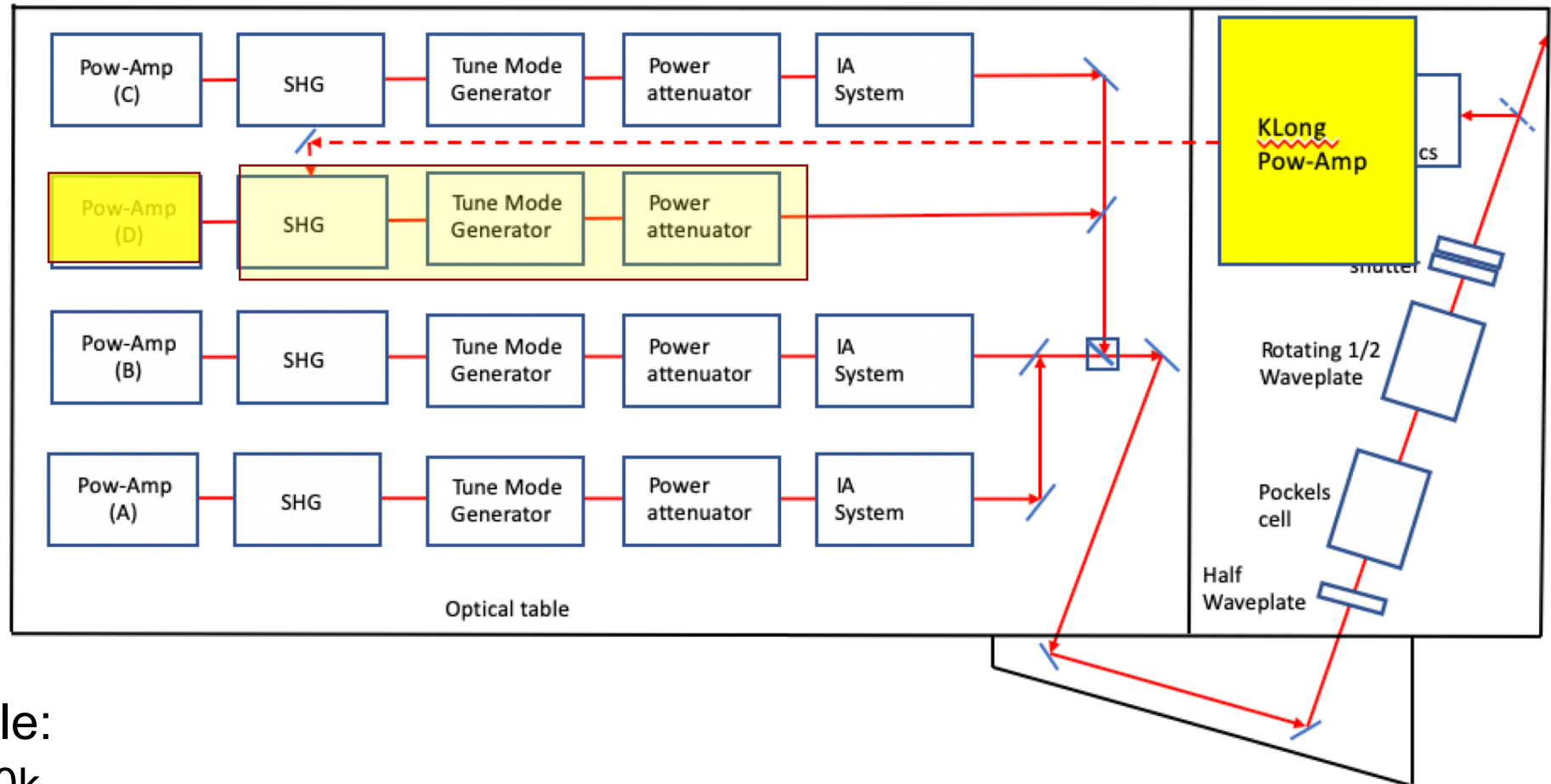

- Cost & Schedule:
  - Amplifier \$60k
  - Delivery possible before September if order soon
  - Installation & test about 1 week

# Summary

---

- **CEBAF Drive lasers**
  - Built on RF-driven seed + Fiber laser amplifiers. Run well
  - Not suitable for low rep-rate/high pulse energy operation mode
- **For K-Long Experiment**
  - Existing system could be used with additional pulse control system, risk of damage exists
- **Solution**
  - Replace existing power amplifier with one designed for high pulse energy operation
  - A vendor identified for a custom-piece with large margin against damage
  - Delivery and installation 3~4 months