

# ***Strange Hadron Spectroscopy with Secondary KL Beam in GlueX***

*Moskov Amaryan*

*Old Dominion University  
Norfolk, VA*

*(on behalf of*  *Collaboration)*

*GlueX Coll. Meeting, JLab, May 16, 2019*

# **Outline**

## **Current Status**

- *Hyperon Spectroscopy*
- *Strange Meson Spectroscopy*

## **Future Prospects with $K_L$ Facility at JLab**

- *Electron Beam*
- *Compact Photon Source*
- *Be Target*
- *Flux Monitor*
- *$K_L$  Beam*
- *$LH_2/LD_2$  Target*

## **Summary**

# Hyperon Spectroscopy

According to *LQCD* there should be many more states including hybrids (thick bordered)

**8-states**  
\*\*\*\*  
**5-states**  
\*\*\*

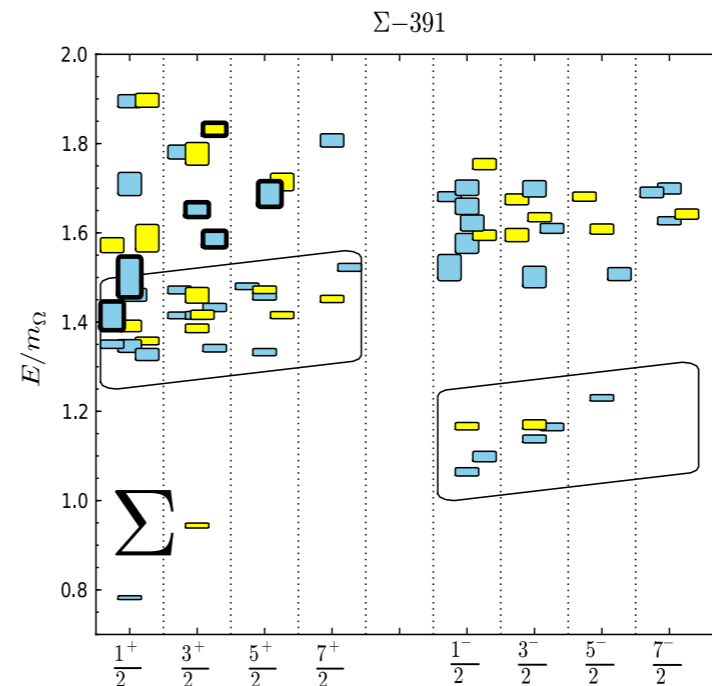
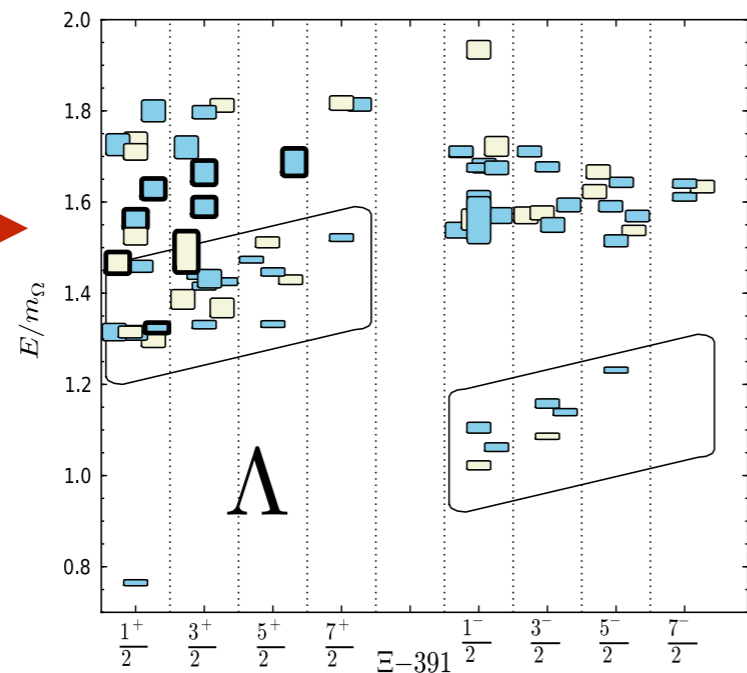

**6-states**  
\*\*\*\*  
**4-states**  
\*\*\*

**3-states**  
\*\*\*\*  
**4-states**  
\*\*\*

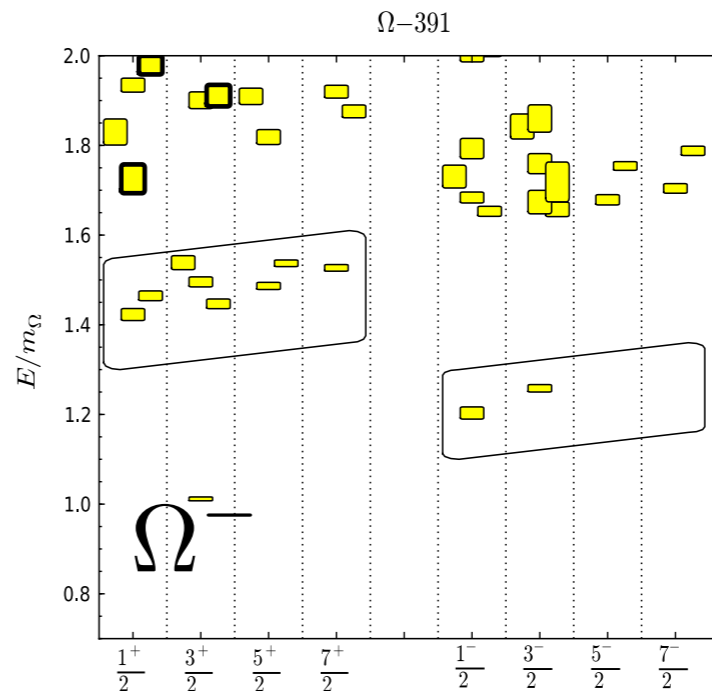
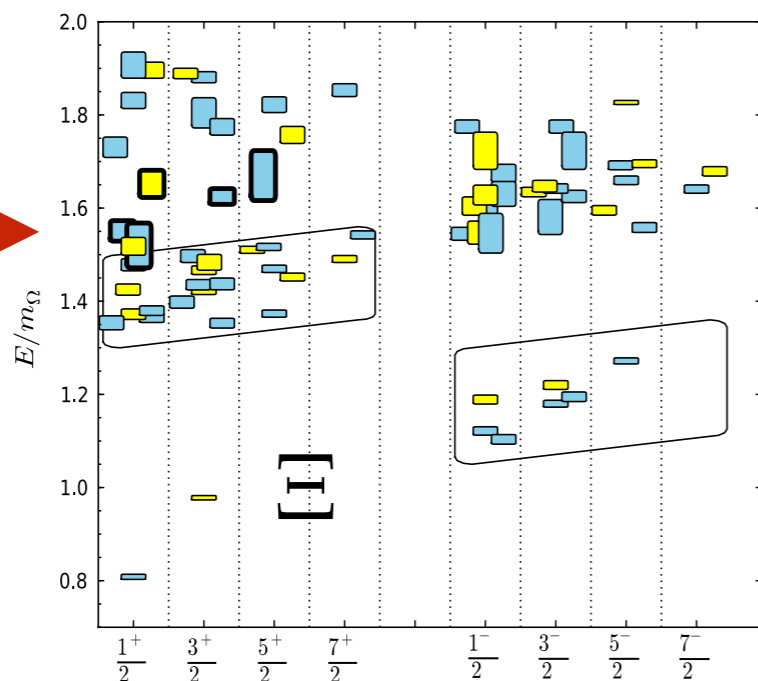

**1-state**  
\*\*\*\*  
**1-state**  
\*\*\*

Edwards, Mathur, Richards and Wallace, Phys. Rev. D 87, 054506 (2013)

# Measurements on Proton Target

**existing data**

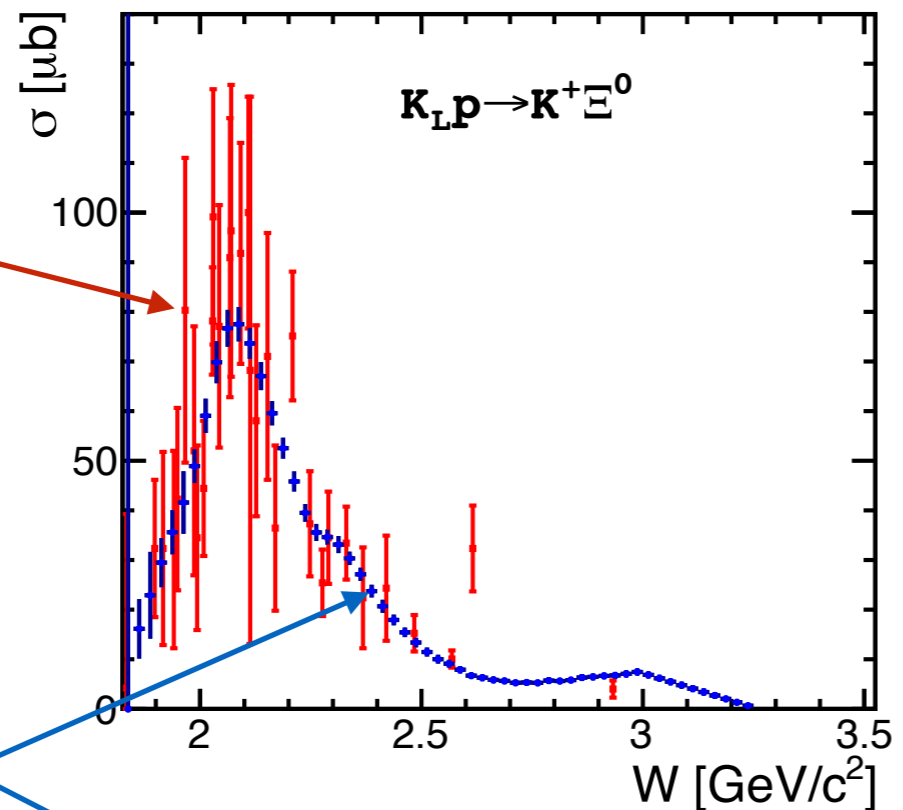

**KLF 100 days**

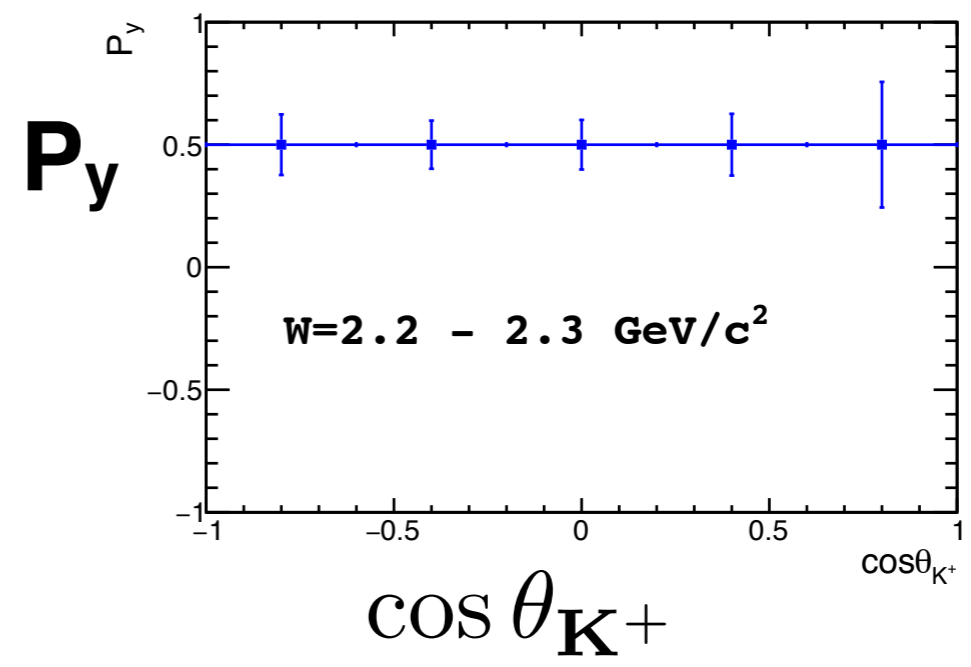
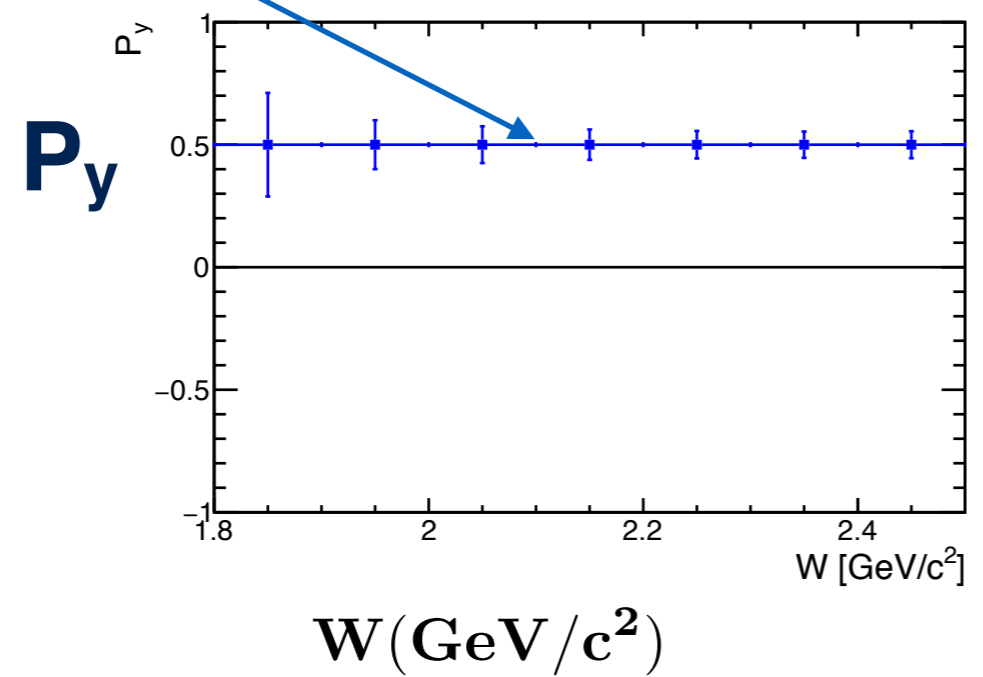
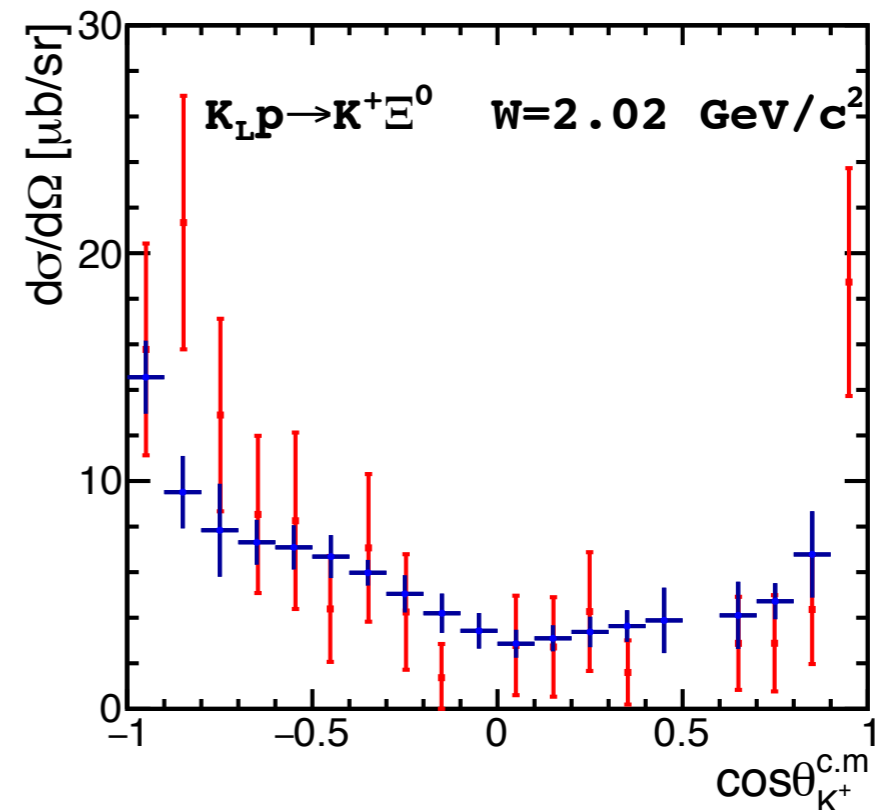



# ***Search for Hyperon Resonances with PWA***

**For Scattering experiments on both proton & neutron targets one needs to determine:**

- differential cross sections**
- self polarization of strange hyperons**
- perform coupled-channel PWA**
- look for poles in complex energy plane  
(contrary to naïve bump hunting)**
- identify all  $\Lambda^*$ ,  $\Sigma^*$ ,  $\Xi^*$  &  $\Omega^*$  up to 2400 MeV**

**we use KN scattering data with statistics generated according to expected K-long Facility (KLF) data for 20 and 100 days to show PWA sensitivity to obtain results close to the best fit**

# Bonn-Gatchina PWA

Total Cross Section

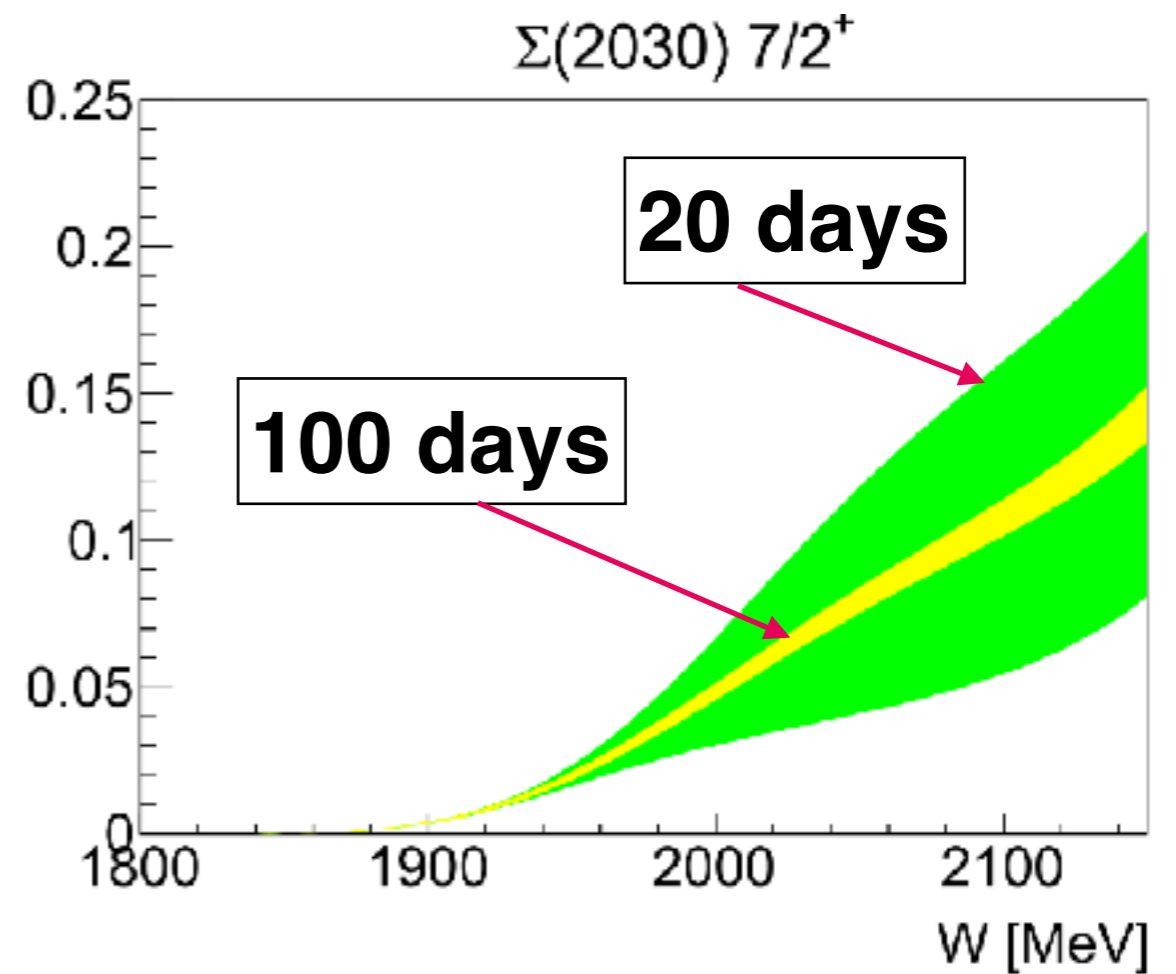
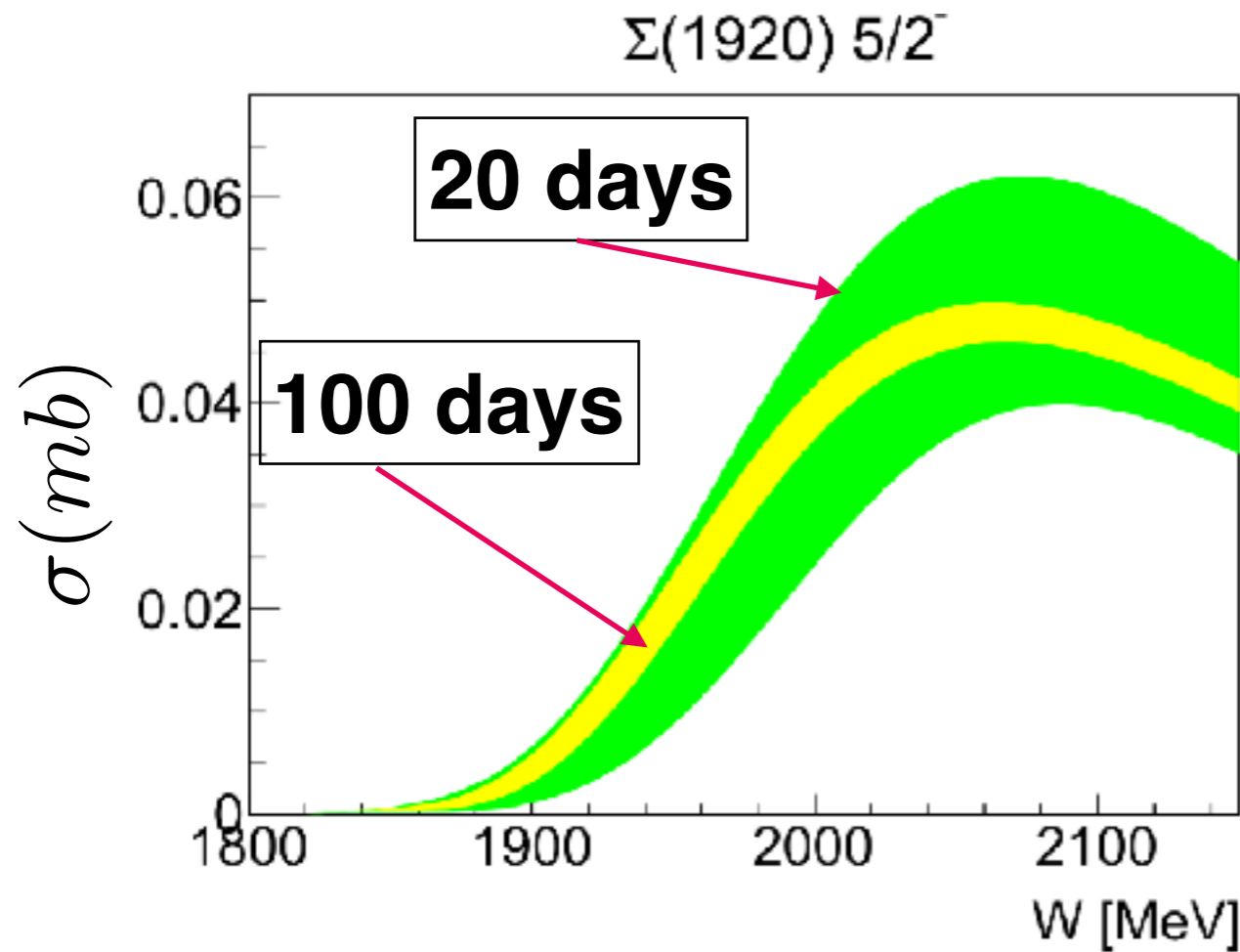
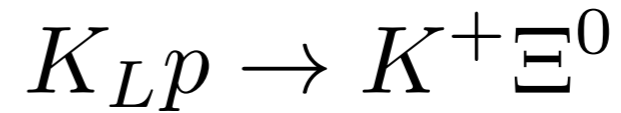

**Obviously: at least 100 days** needed to get precise solution

# Bonn-Gatchina PWA

## Diff. Cross Section

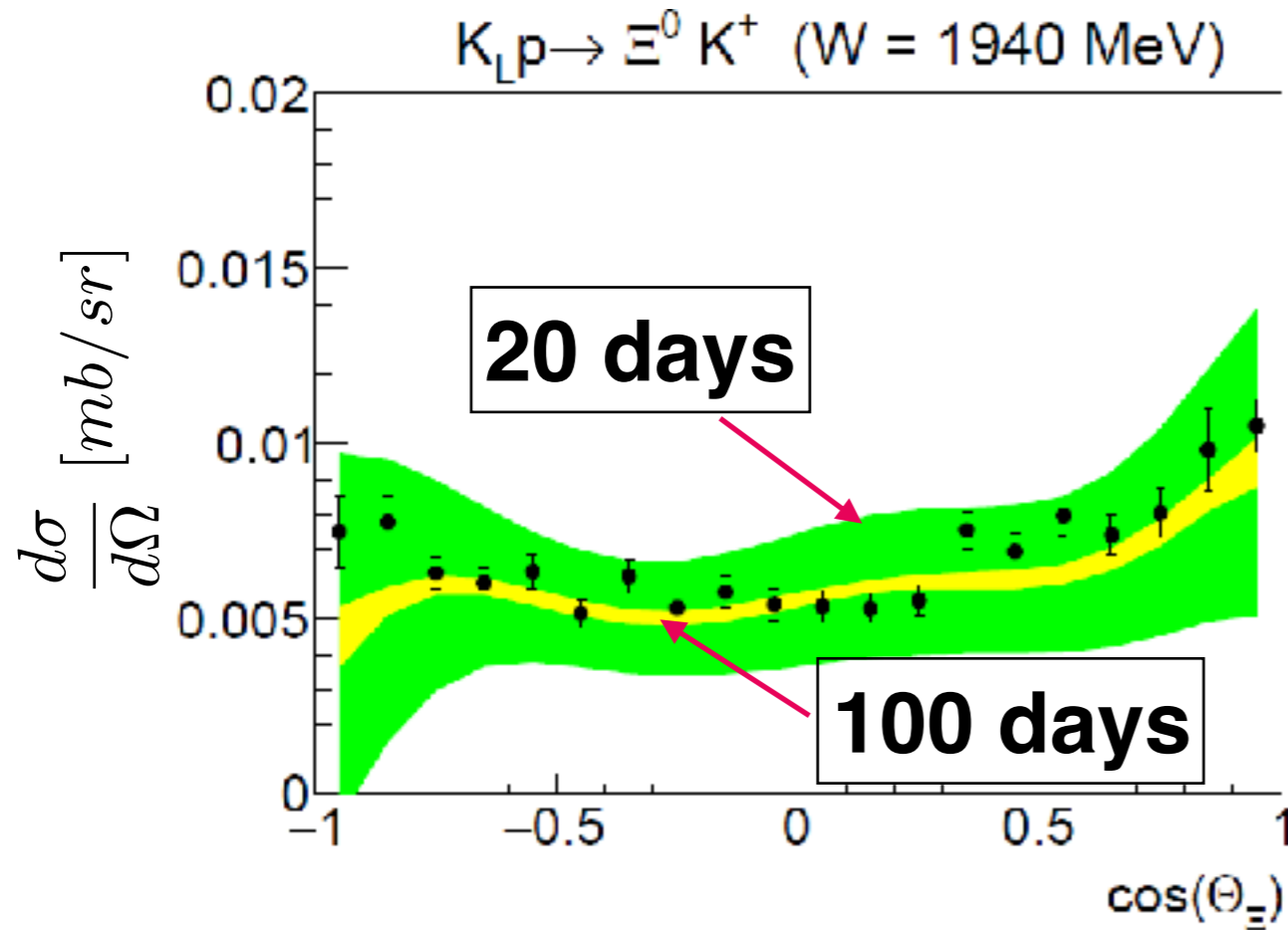

## Polarization

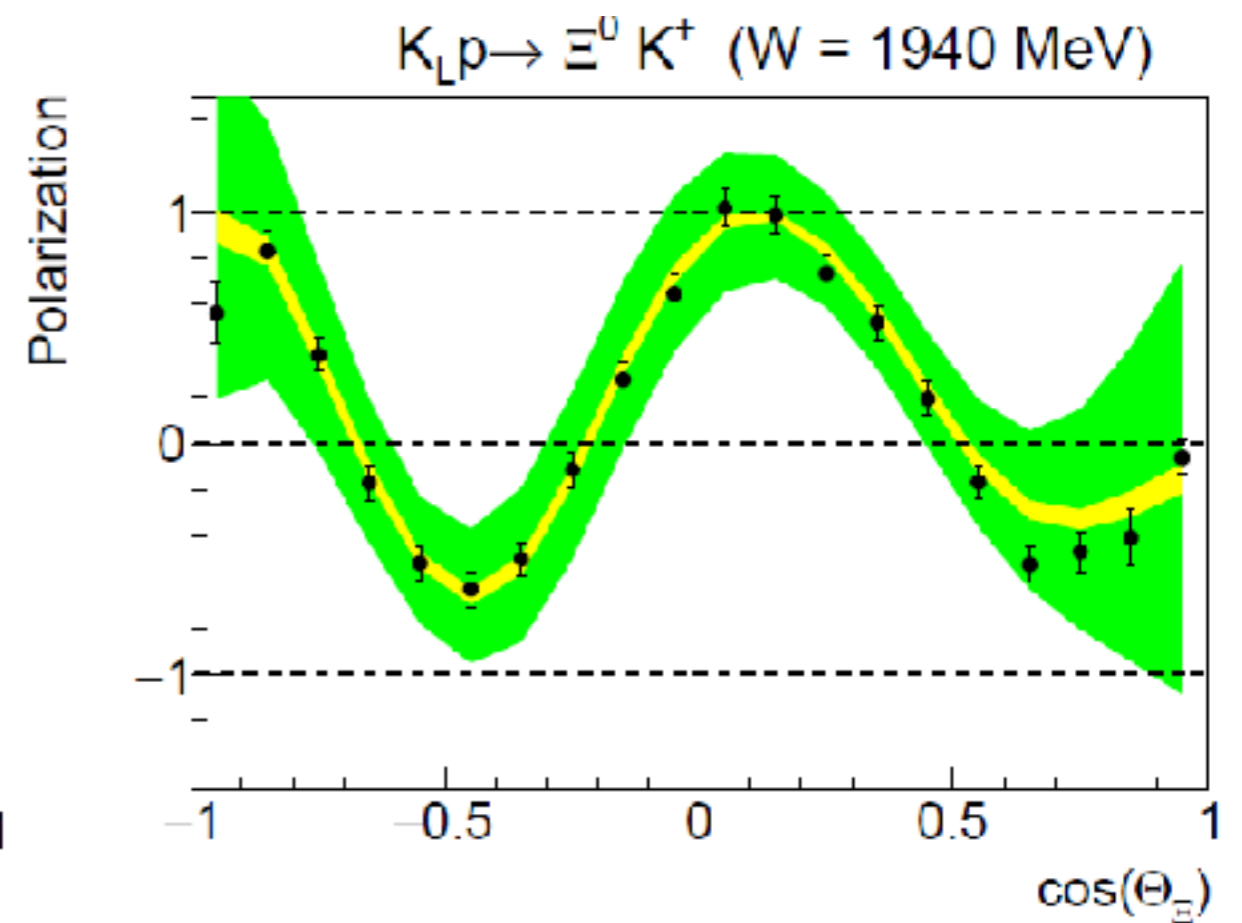

Again: **at least 100 days** to get precise solution

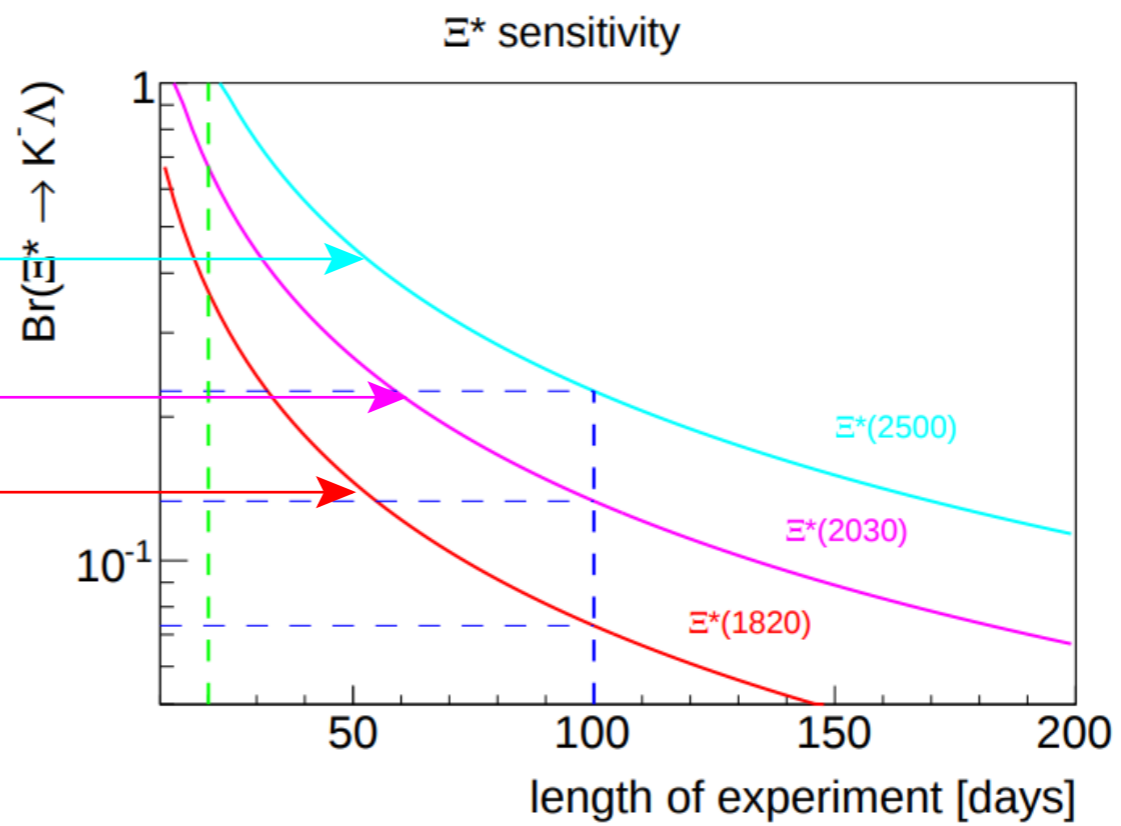
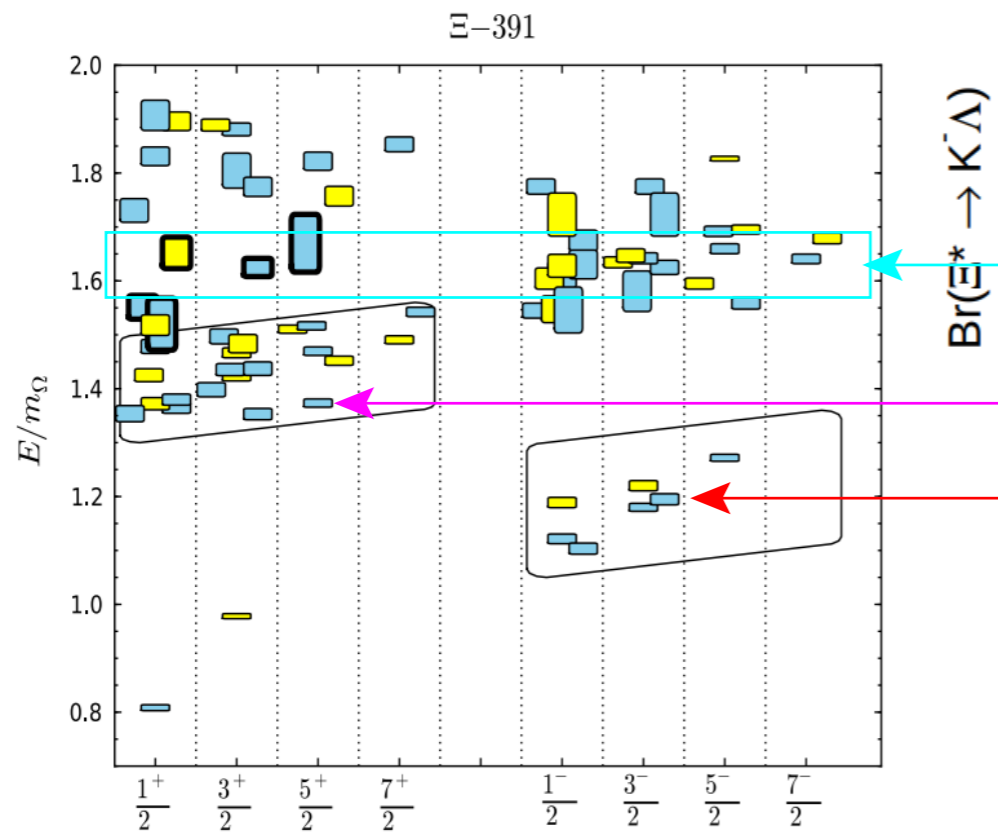
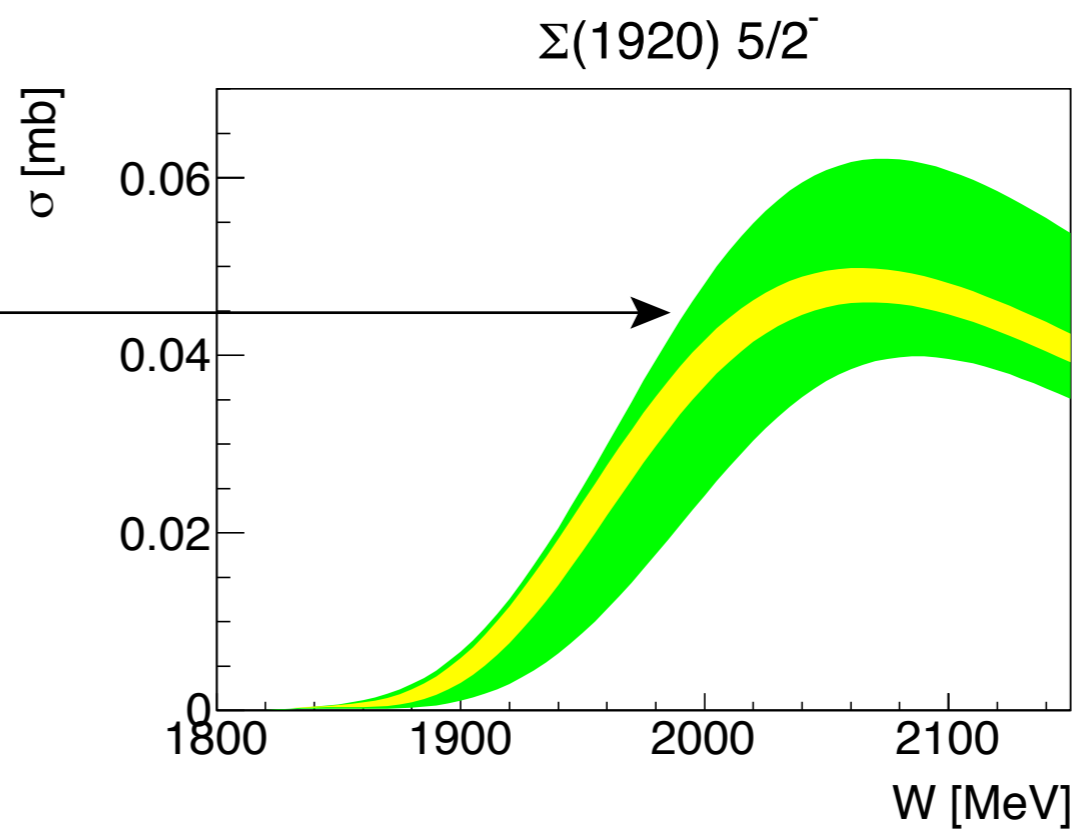
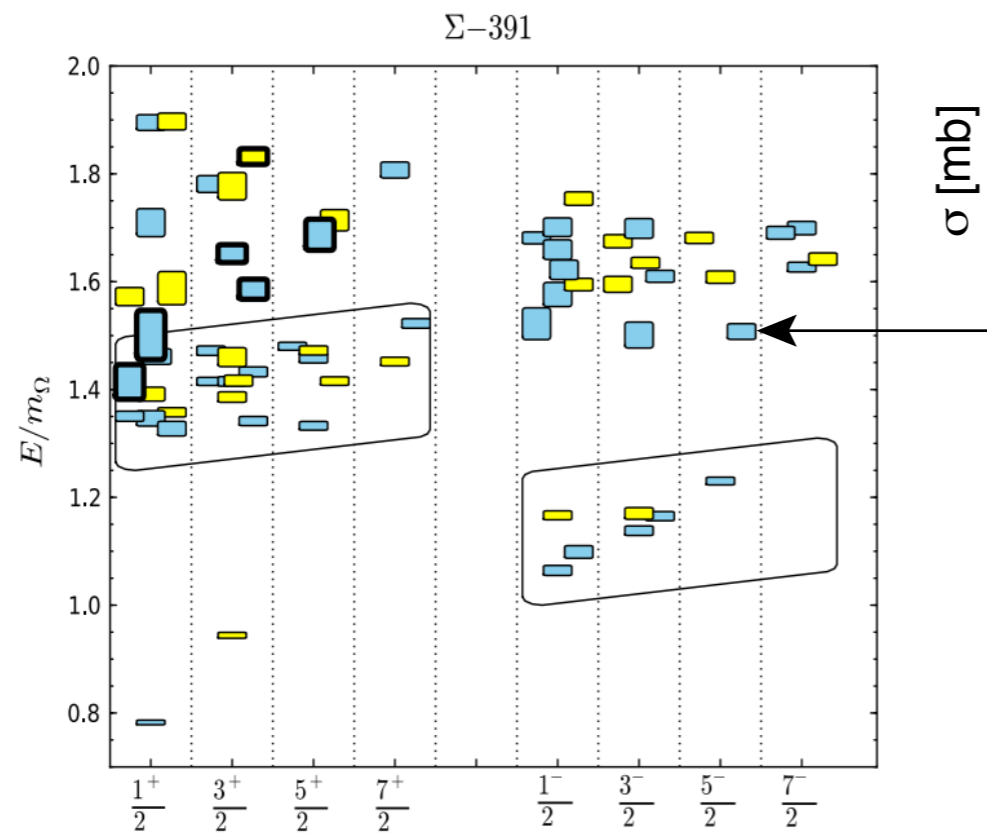

## Some Numerical Results

**Simulated**  $\Sigma(1920) \ 5/2^-$



$$\left\{ \begin{array}{l} 100d \ M = \underline{1.923} \pm 0.010 \pm 0.010 \text{ GeV} \\ \quad \Gamma = 0.321 \pm 0.01 \pm 0.010 \text{ GeV} \\ 20d \ M = \underline{1.977} \pm 0.021 \pm 0.025 \text{ GeV} \\ \quad \Gamma = 0.327 \pm 0.025 \pm 0.025 \text{ GeV} \end{array} \right.$$

$$PDG2018 \ M = 1.775 \pm 0.005$$

$$LQCD \ M = 1.212 \text{ GeV}$$

# Strange Meson Spectroscopy

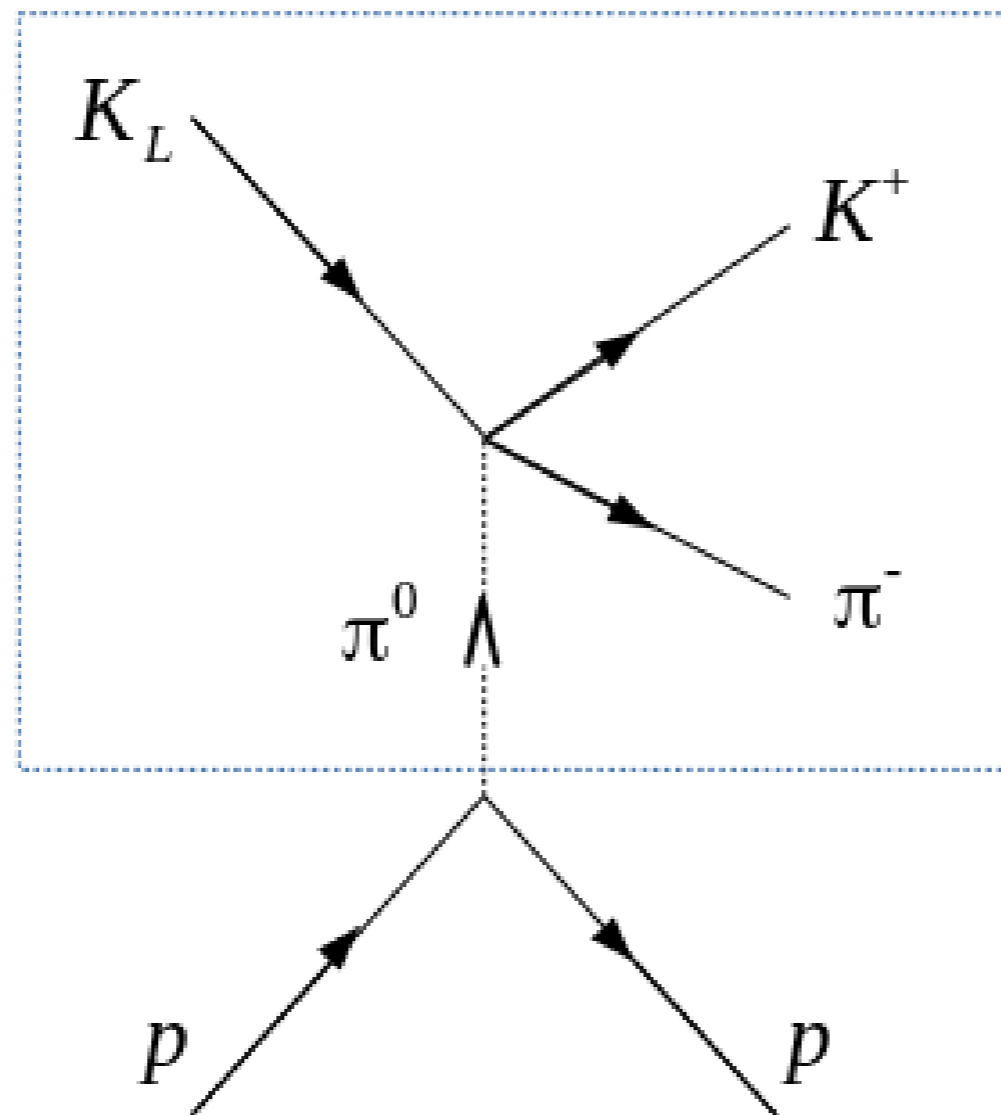
## $K\pi$ Scattering



# Proposed Measurements

SLAC

$$K^- \pi^+ \rightarrow K^- \pi^+$$

Belle

$$\tau \rightarrow K \pi \nu_\tau$$

KLF

$$K_L \pi^0 \rightarrow K^+ \pi^-$$

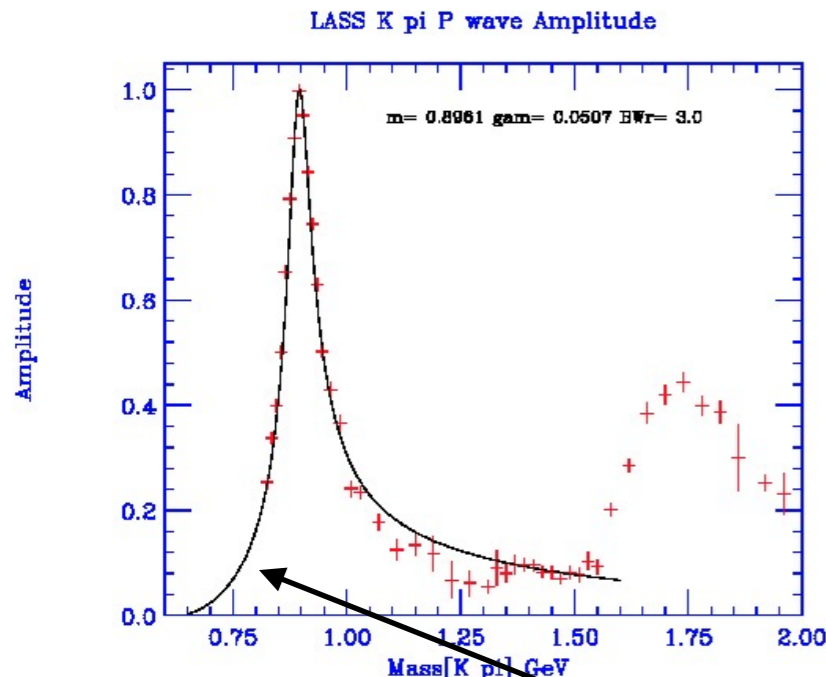

$M(K\pi)$  (GeV)

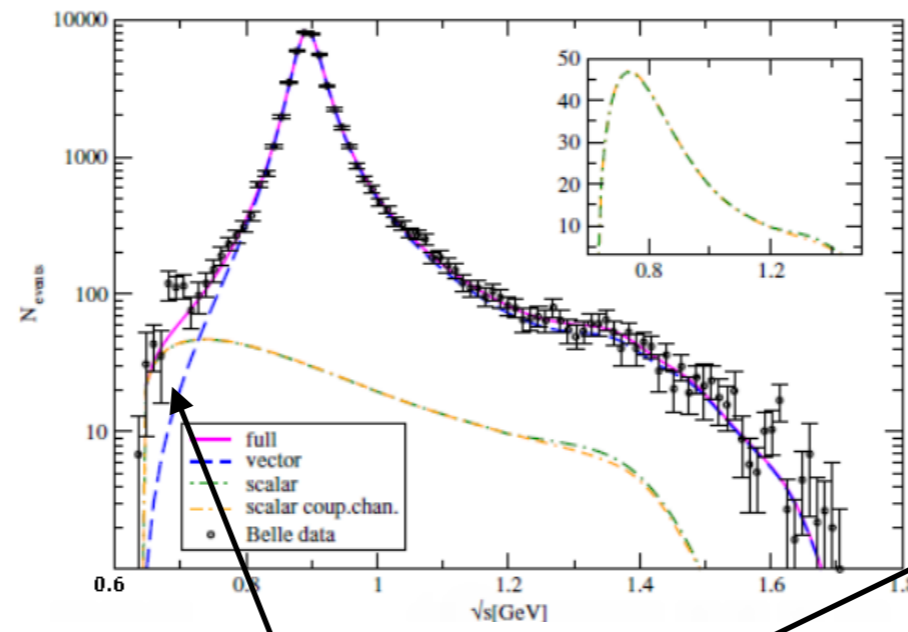

$M(K\pi)$  (GeV)

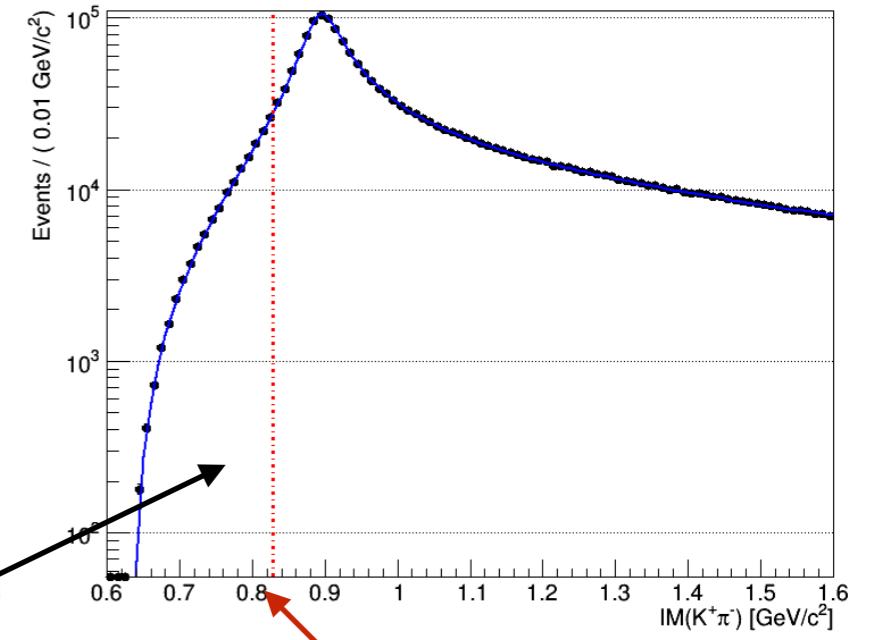

$M(K\pi)$  (GeV)

region of  $\mathcal{K}(800)$

SLAC Lower limit

# Projected Measurements

$I=3/2+1/2$

$S$ -wave

SLAC Data

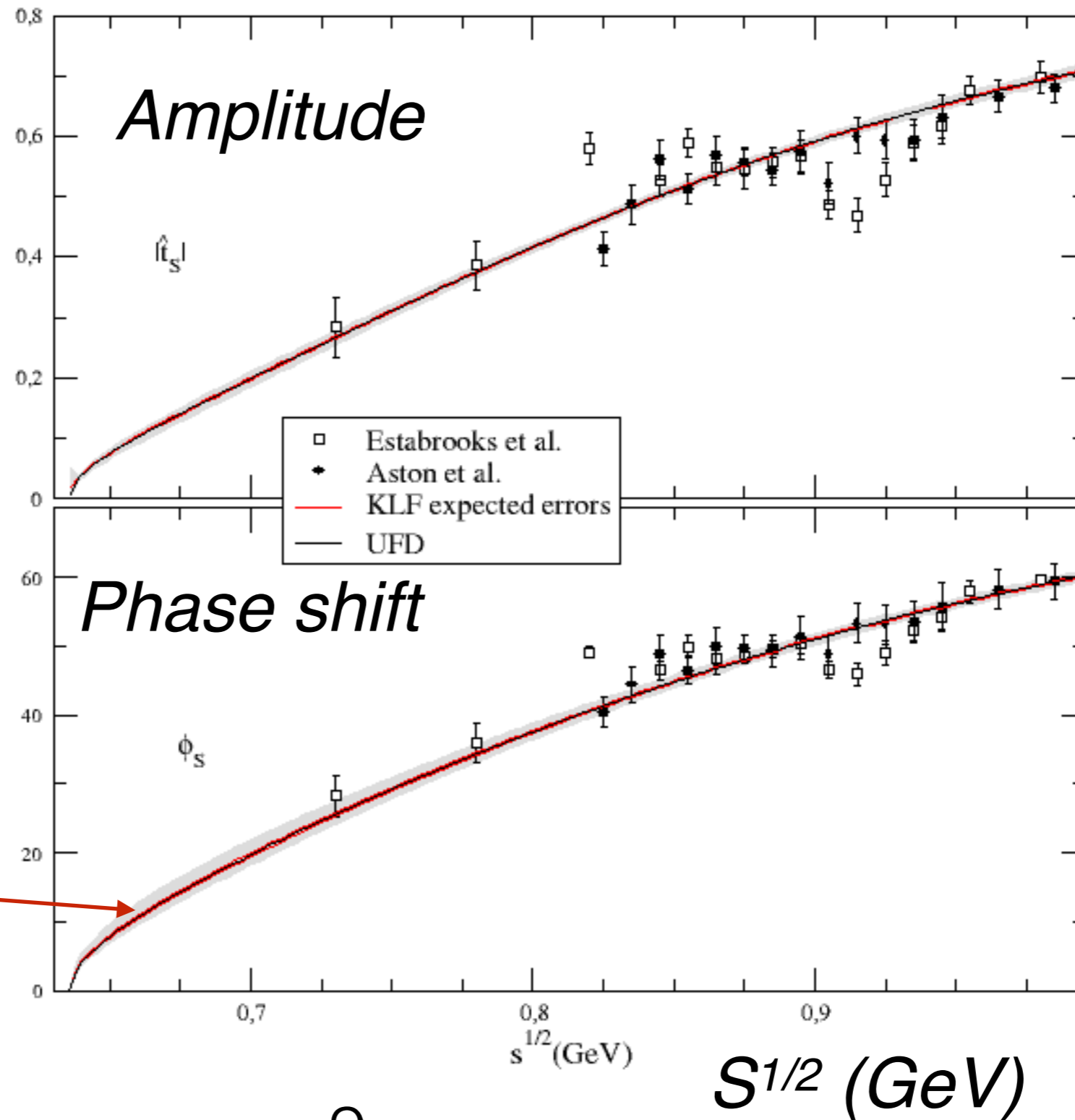



$I=3/2$   $S$ -wave

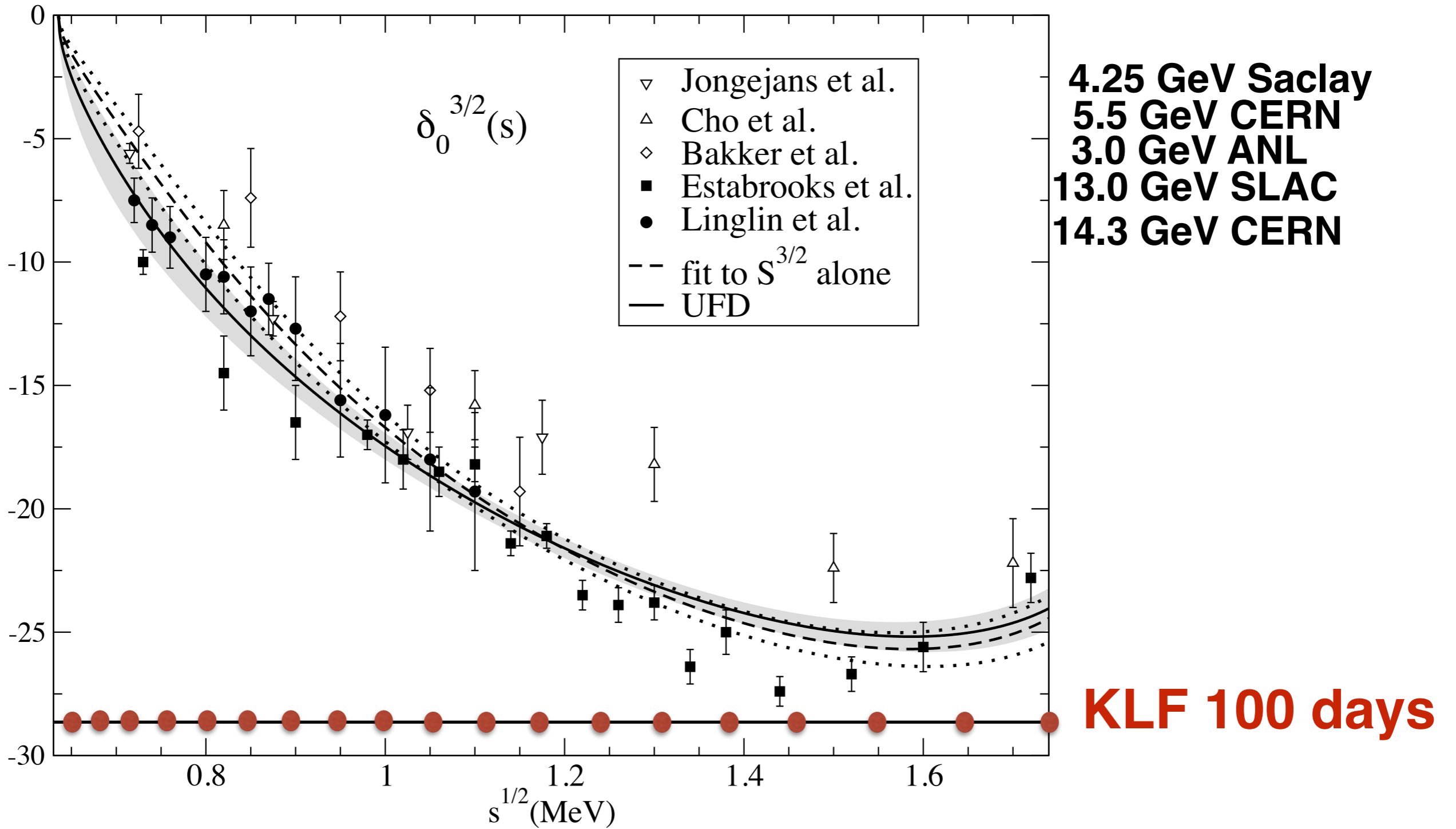

*From Pelaez and Rodas paper: PRD93(2016)*

# Scalar Meson Nonet

$$J^{PC} = 0^{++}$$

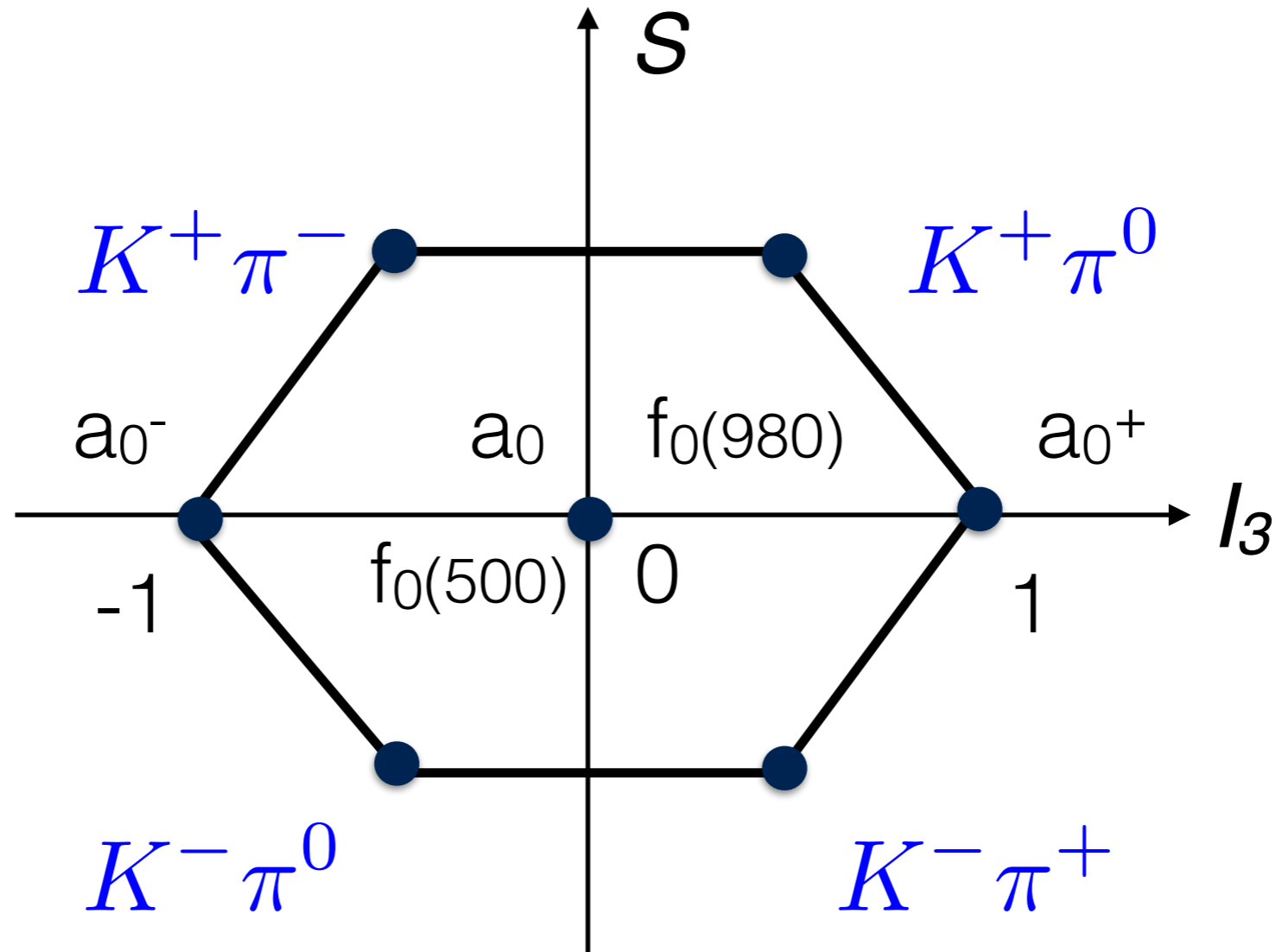

**Four states called  $\kappa$**

**still need further confirmation(PDG)**

**We can measure all of them**

# Width and Mass of $\kappa$

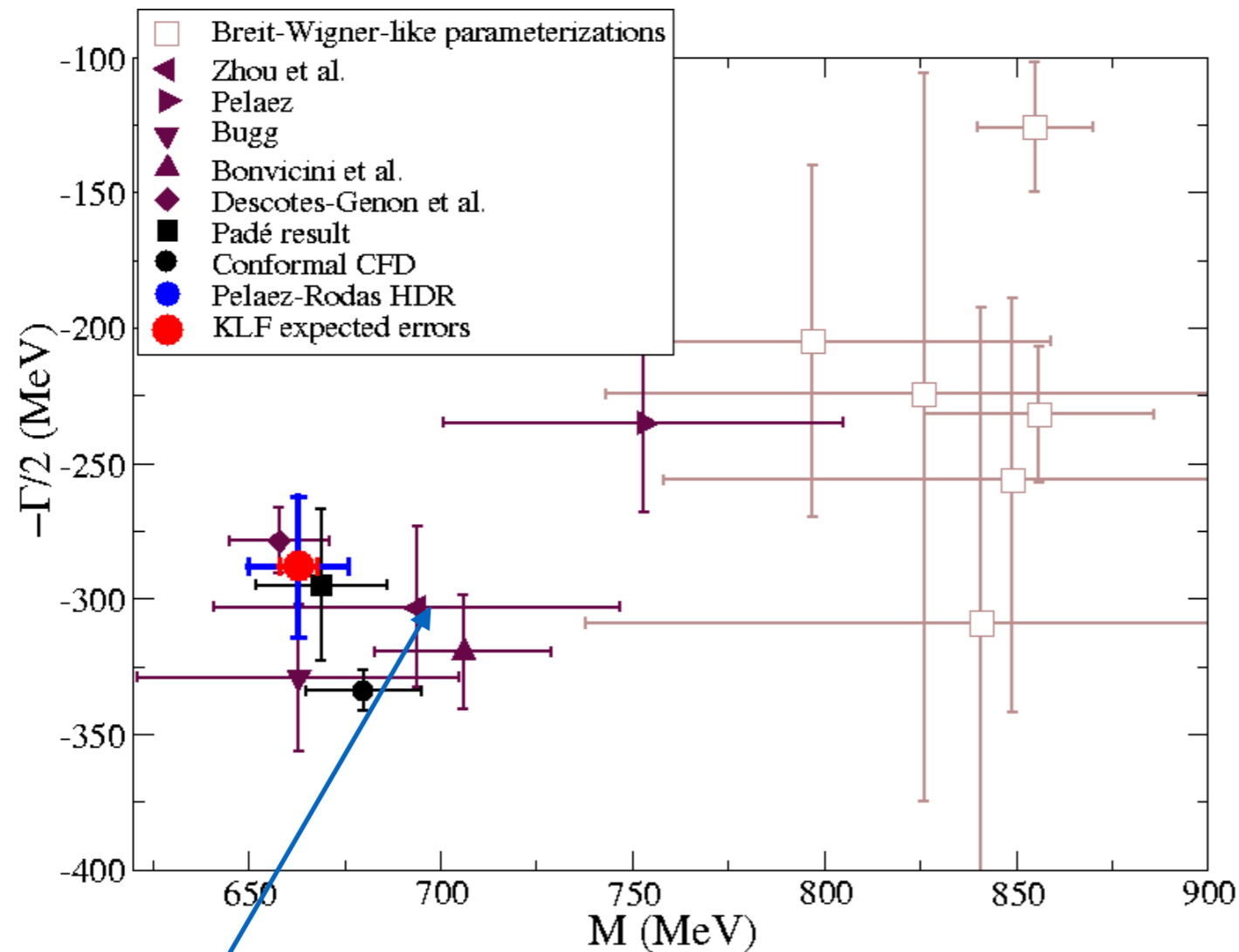

*100 days of running*

Without KLF

$$M_{\kappa} \simeq 663 \pm \underline{14} \text{ MeV}$$

$$\Gamma_{\kappa} = 596 \pm \underline{53} \text{ MeV}$$

**With KLF**

$$M_{\kappa} \simeq 663 \pm \underline{6} \text{ MeV};$$

$$\Gamma_{\kappa} = 596 \pm \underline{10} \text{ MeV}$$

**Precision:**

*factor of 2 in a mass  
factor of 5 in a width*

# Summary of $K\pi$ Scattering

*-The KLF will have a very significant impact on our knowledge on  $K\pi$  scattering amplitudes*

*-It will improve determination of heavy  $K^*$ 's parameters*

*-It will help to settle the tension between phenomenological determinations of scattering lengths from data versus ChPT and LQCD*

*- It will reduce by more than a **factor of two** the uncertainty in the **mass** determination of  $K^*(800)$  and by **factor of five** the uncertainty **on its width**, and therefore **on its coupling***

*-It will clearly resolve the **debate of its existence**, and therefore the long standing problem of **the existence of the scalar nonet***

# Hall-D beamline and GlueX Setup

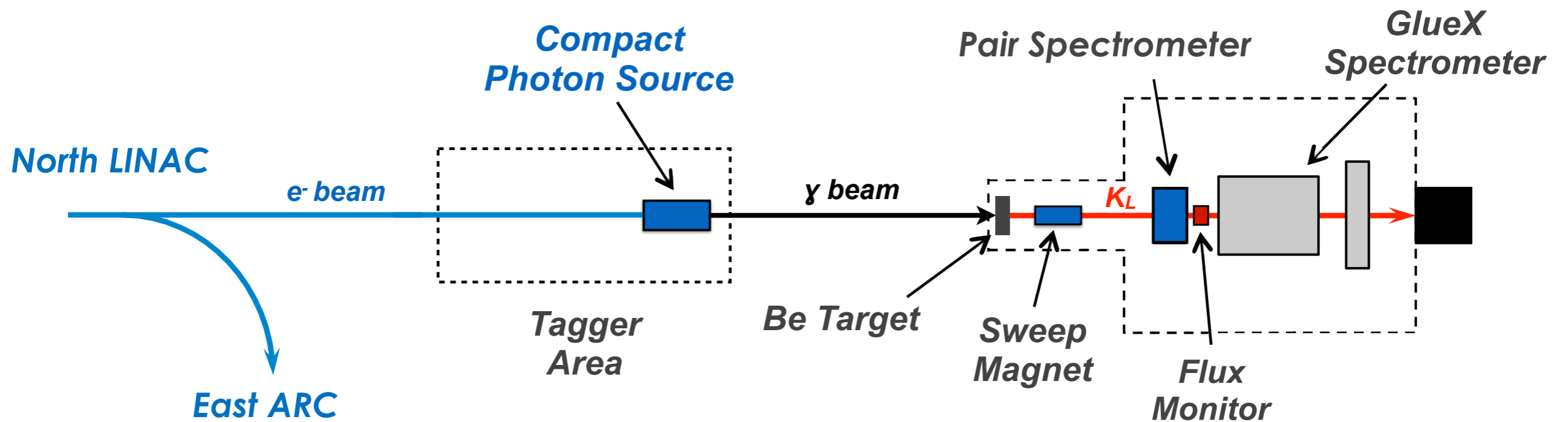

## *Electron Beam Parameters*

$$E_e = 12 \text{ GeV} \quad I = 5 \mu\text{A}$$

$$\text{Bunch spacing} \quad 64 \text{ ns}$$

*No major problems.*

**Doable !**

**Confirmed by accelerator experts**

# Compact Photon Source

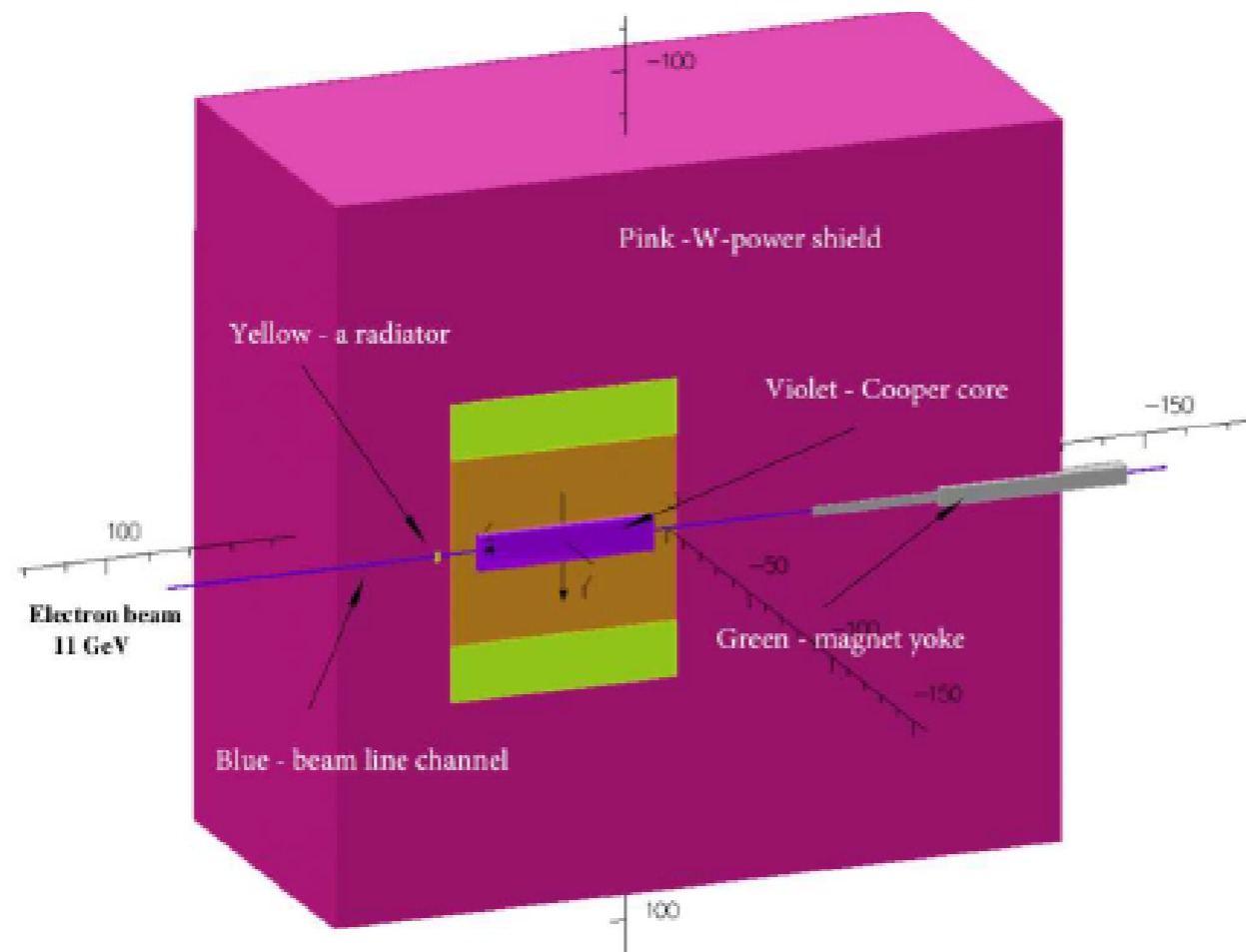

**Conceptual design is completed for Halls A&C**

**The details of the CPS are designed by the CPS Collaboration**

**Meets RadCon Radiation Requirements**

# Be Target Assembly: Conceptual Design

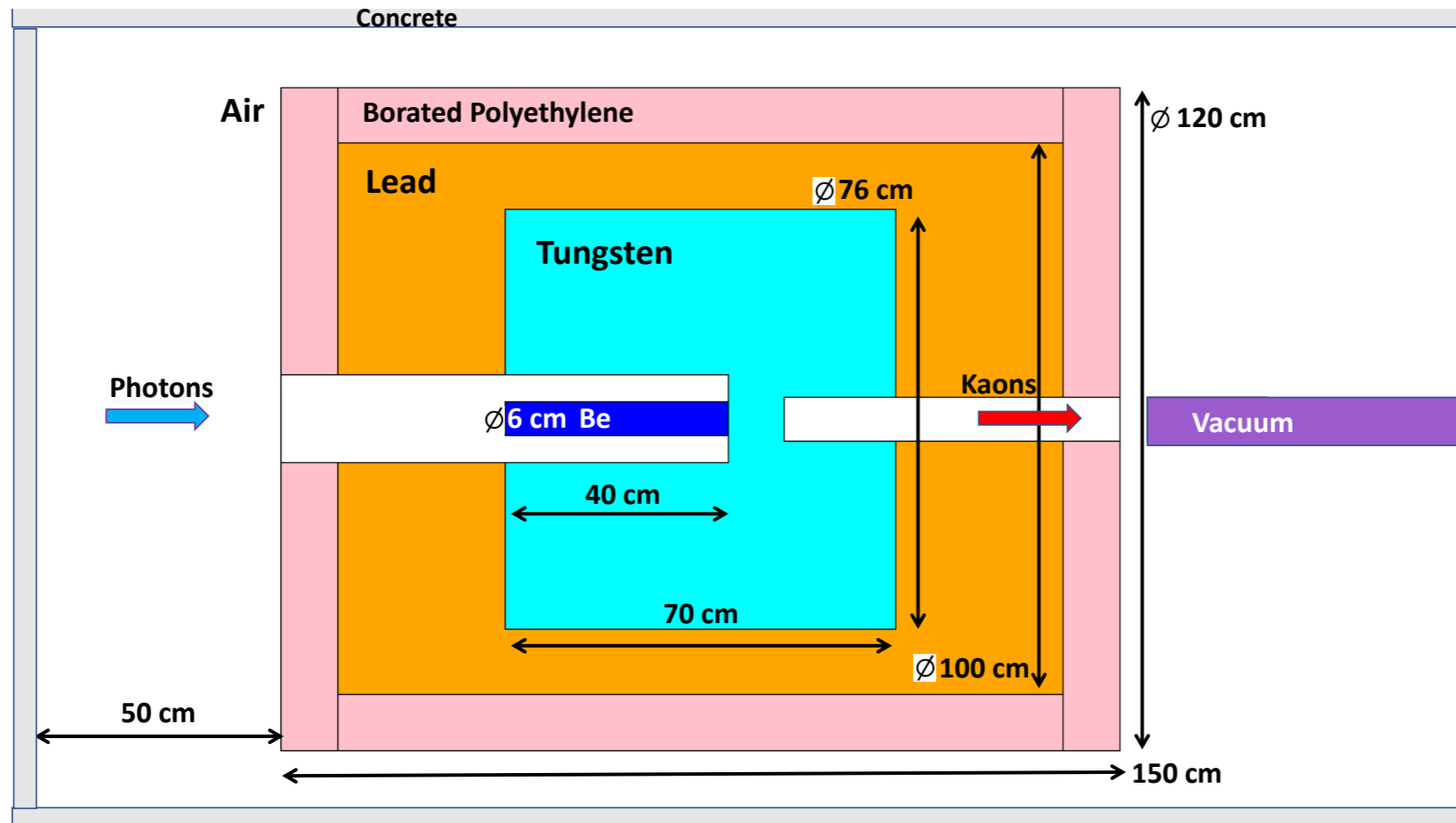

-Meets RadCon Radiation Requirements

-Conceptual Design Endorsed by Hall-D Engineering Staff



# Flux Monitor

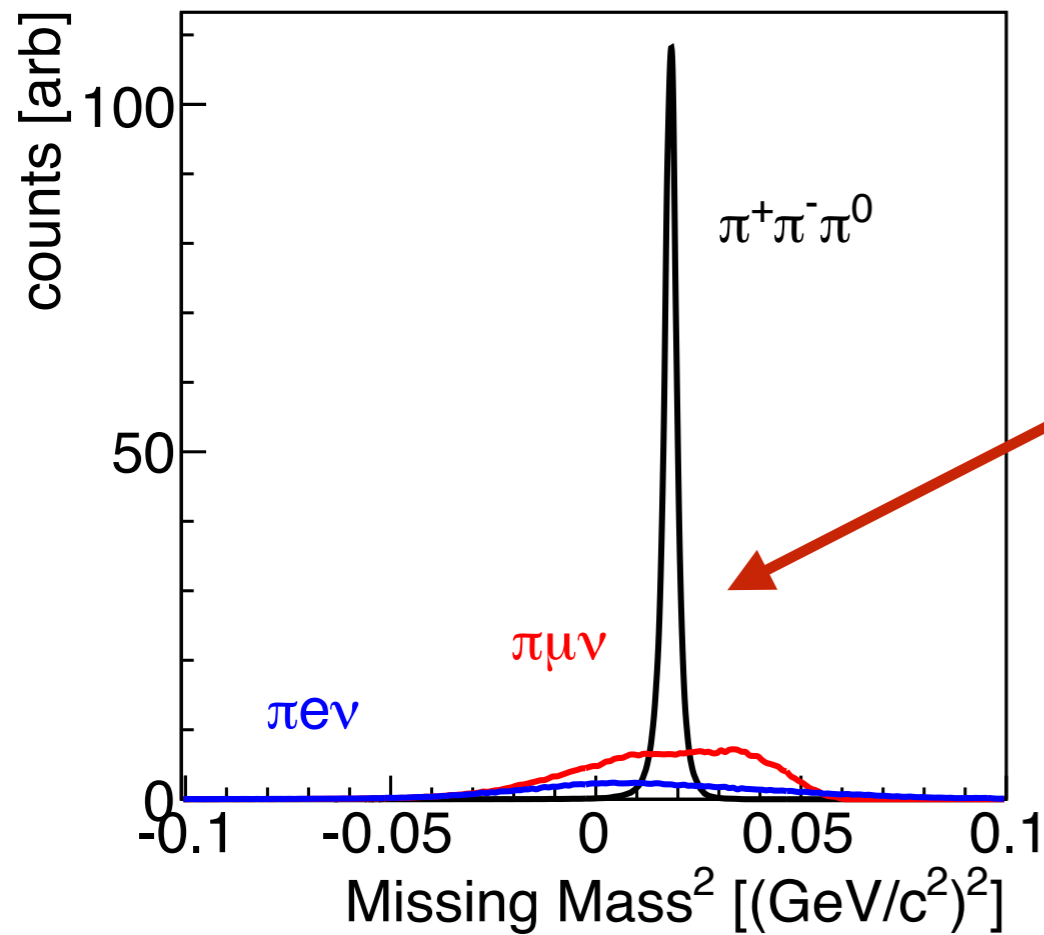
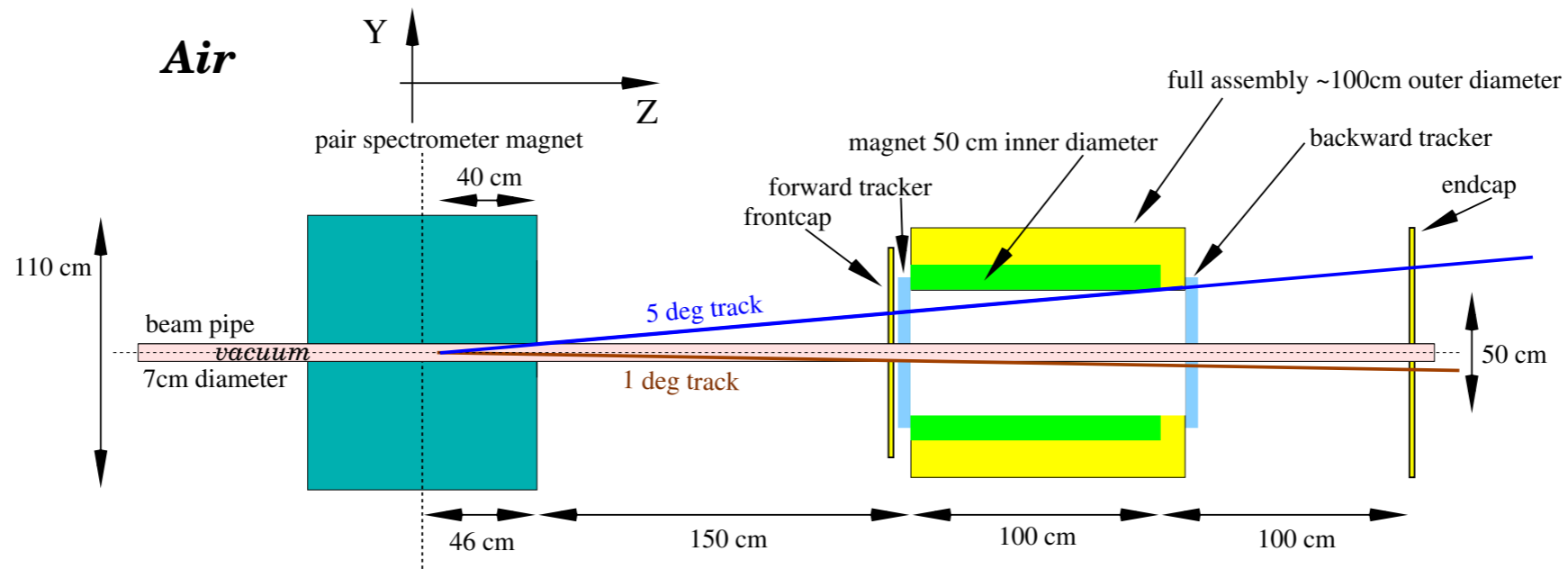

796cm to LH2/LD2 target

**Reconstructed  $K_L$  mass**

**Flux measurement stat. err. <1%**

**Estimated syst. err. ~5%**

# $K_L$ Beam Flux

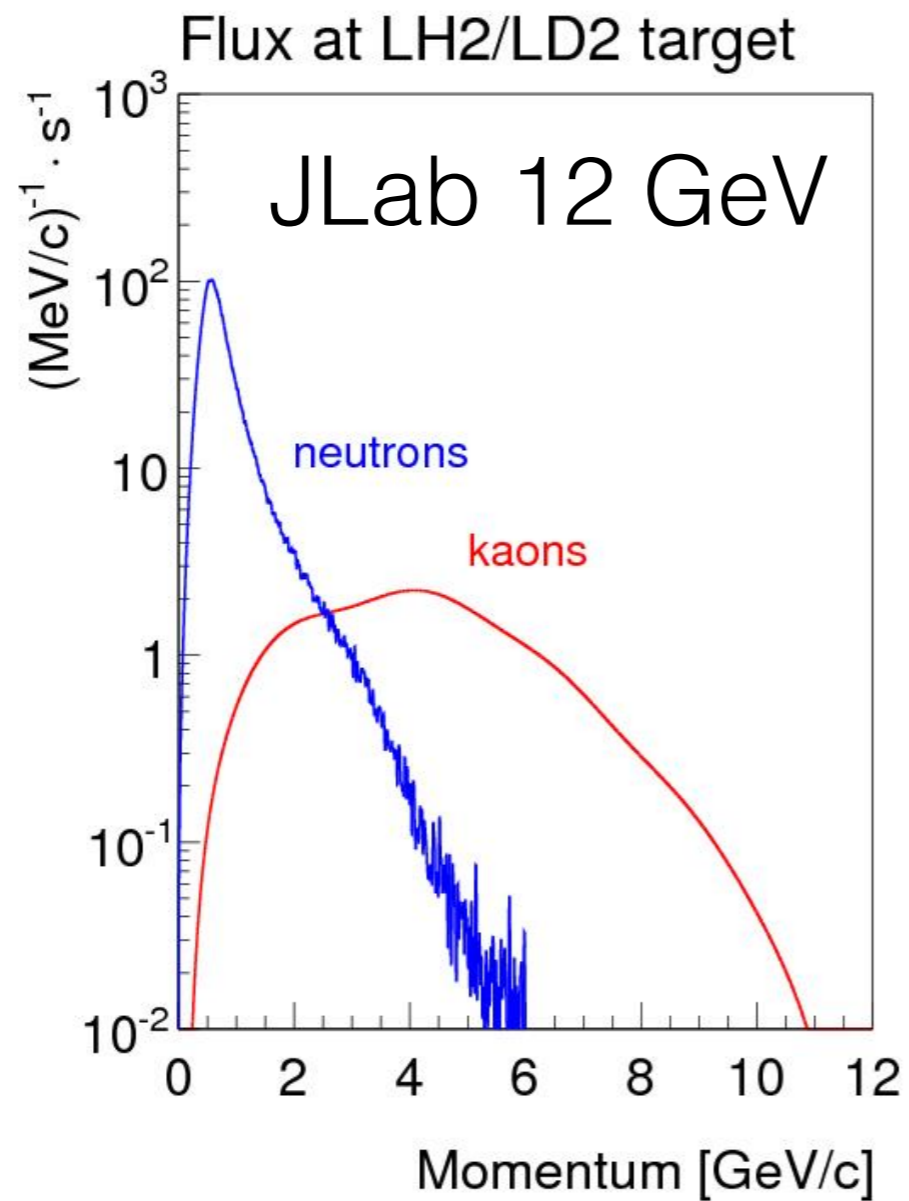

$$N(K_L)/sec \sim 10^4$$

# SLAC 16 GeV

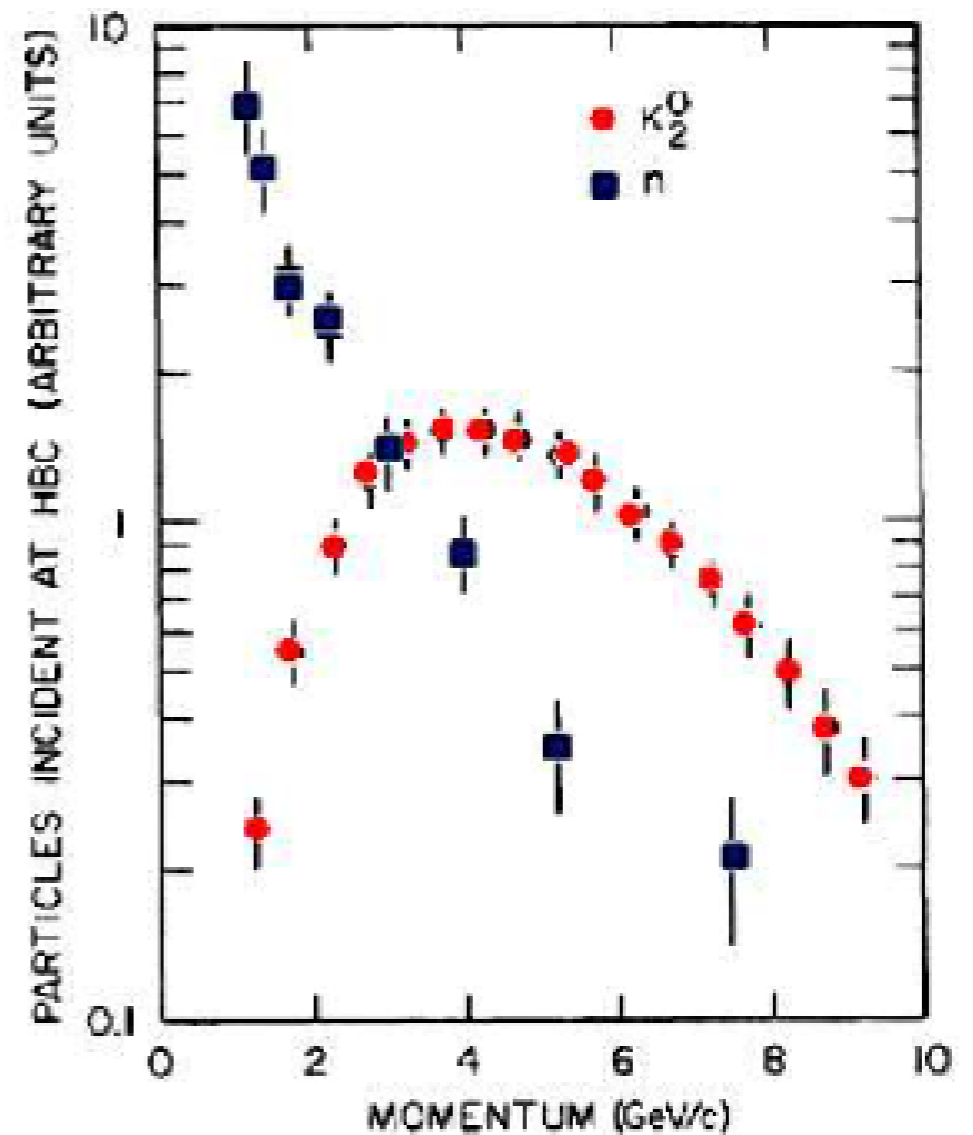

$$\frac{N(K_L)_{JLAB}}{N(K_L)_{SLAC}} \sim 10^3$$

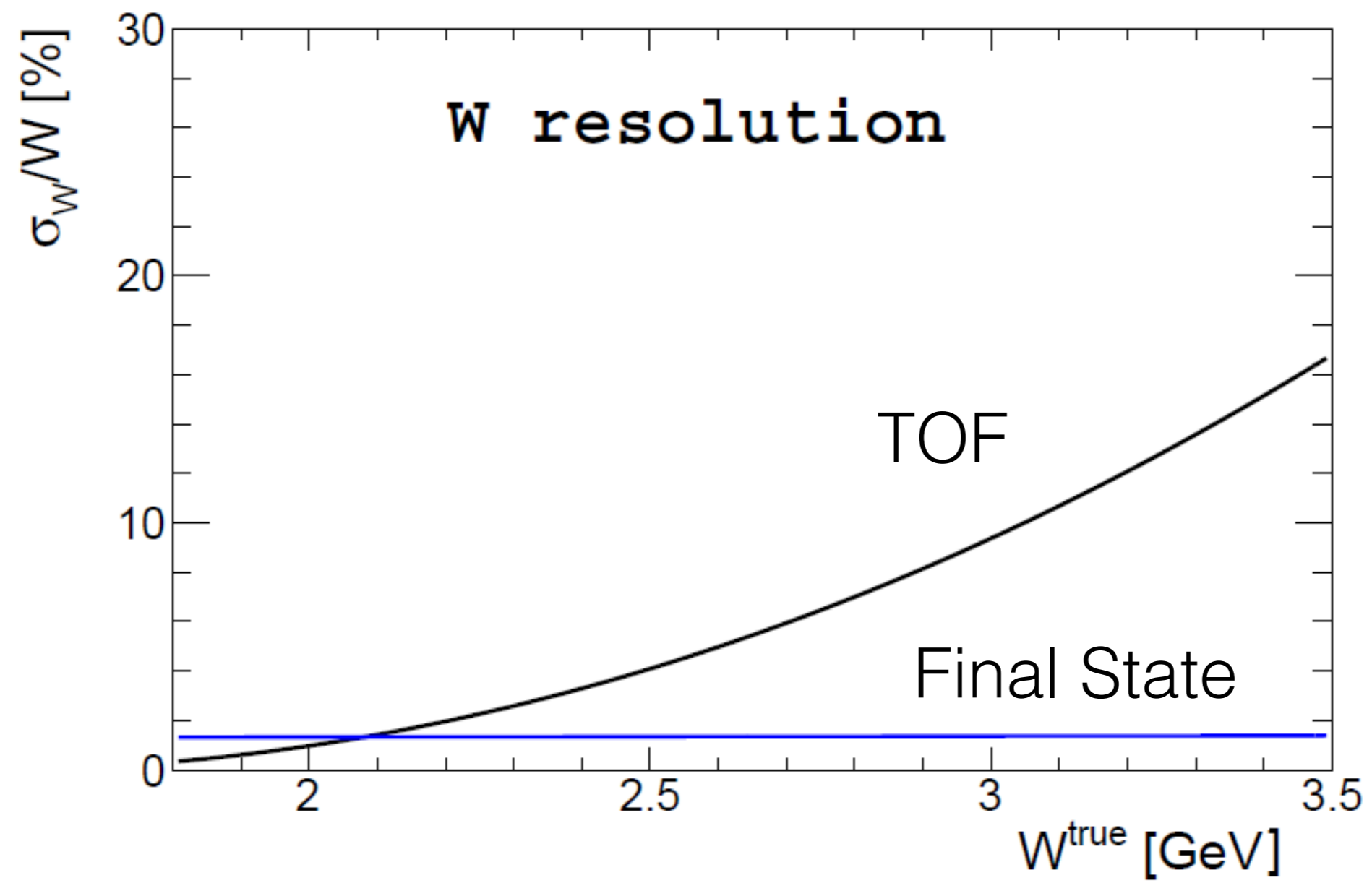

# LH<sub>2</sub>/LD<sub>2</sub> Cryogenic Target for Neutral Kaon Beam at Hall D

The GlueX liquid hydrogen target.

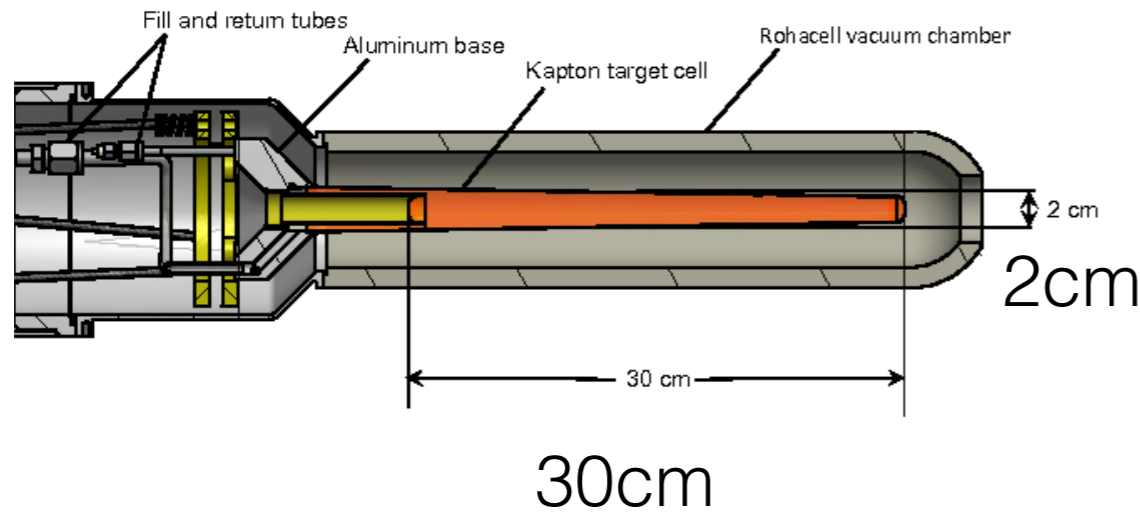

*Current*

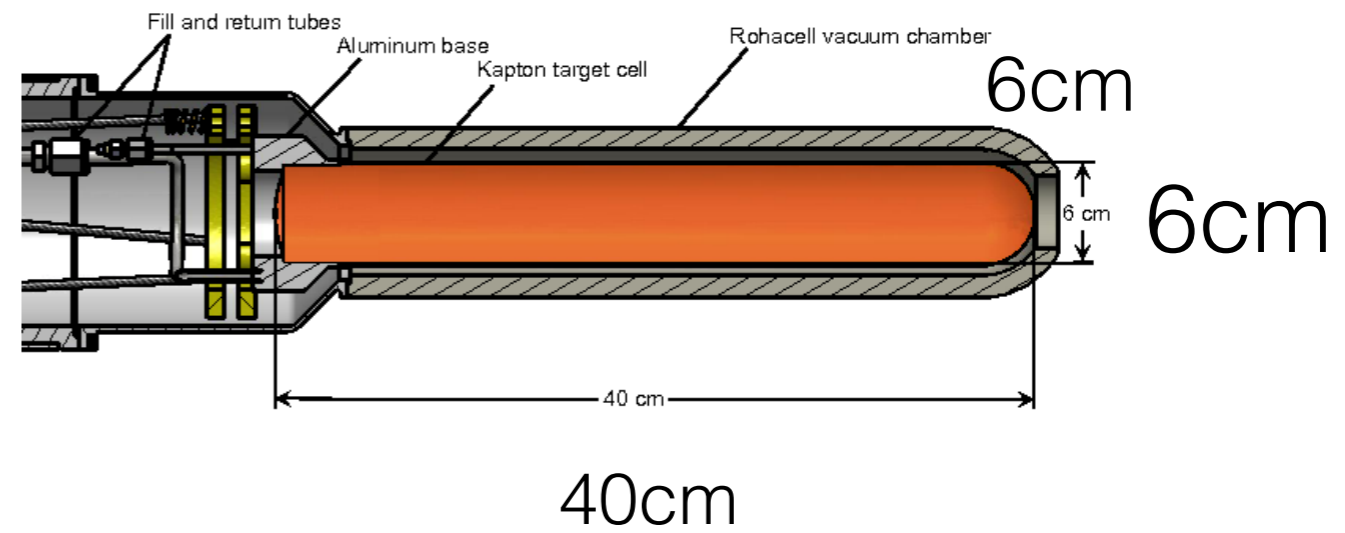

*Proposed & Feasible*

**Longer and thicker target is needed to enhance production rate**

**Conceptual design has been endorsed by the JLAB target group**

# $K\pi$ Scattering Resolutions

Four Momentum Resolution for  $K_L p \rightarrow K^+ \pi^- p$

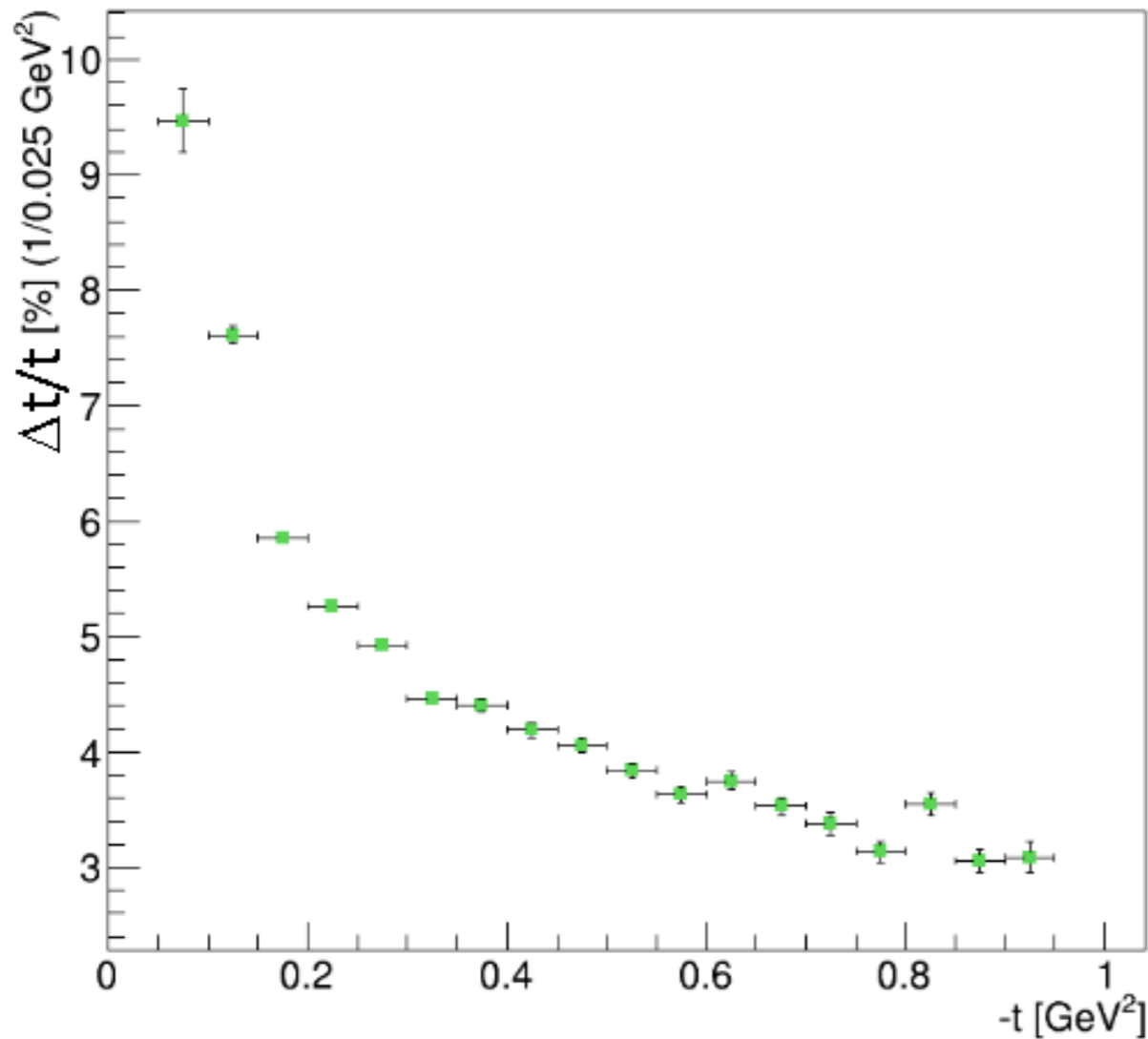

$K^+ \pi^-$  Invariant Mass Resolution for  $K_L p \rightarrow K^+ \pi^- p$

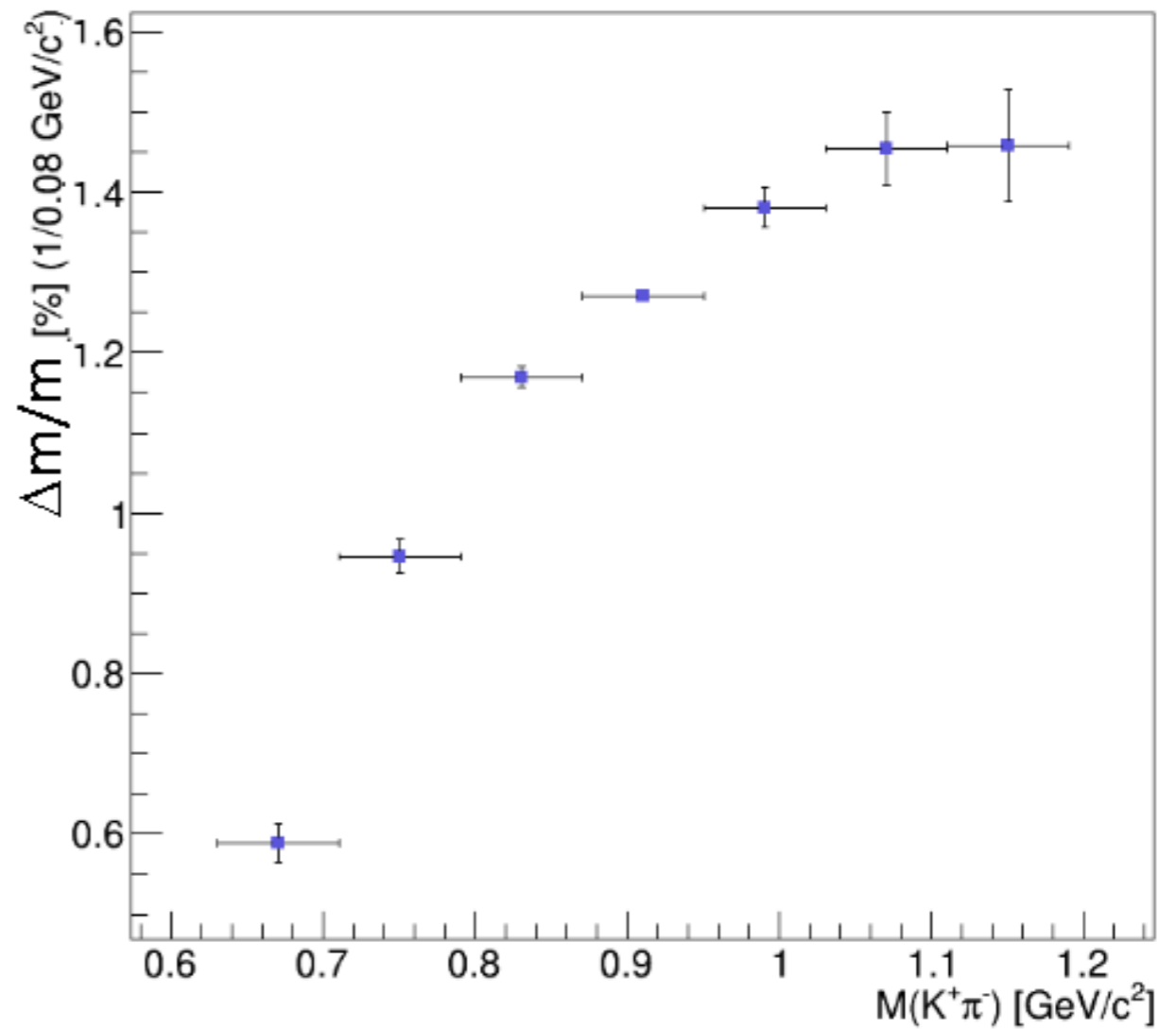

*-Good resolution at low- $t$  is needed to be close to pion pole*

*-Binning in  $\sim 10 \text{ MeV}$  will cover almost entire elastic  $K$ - $\pi$  scattering range*



PHYSICS WITH NEUTRAL KAON BEAM AT JLAB  
**KL2016**

FEBRUARY 1-3, 2016  
JEFFERSON LAB  
NEWPORT NEWS, VIRGINIA

**SCOPE**

The Workshop is following Lo112-15-001 "Physics Opportunities with Secondary KL beam at JLab" and will be dedicated to the physics of hyperons produced by the kaon beam on unpolarized and polarized targets with GlueX set up in Hall D. The emphasis will be on the hyperon spectroscopy. Such studies could contribute to the existing scientific program on hadron spectroscopy at Jefferson Lab.

The Workshop will also aim at boosting the international collaboration, in particular between the US and EU research institutions and universities.

The Workshop would help to address the comments made by the PAC43, and to prepare the full proposal for the next PAC44.

**ORGANIZING COMMITTEE**

Moskov Amaryan, ODU, chair  
Eugene Chudakov, JLab  
Curtis Meyer, CMU  
Michael Pennington, JLab  
James Ritman, Ruhr-Uni-Bochum & IKP Jülich  
Igor Strakovsky, GWU

[WWW.JLAB.ORG/CONFERENCES/KL2016](http://WWW.JLAB.ORG/CONFERENCES/KL2016)



**YSTAR**  
Excited Hyperons in QCD  
Thermodynamics at Freeze-Out **2016**

NOVEMBER 16-17, 2016

Jefferson Lab  
Newport News, Virginia

A workshop to discuss the influence of possible "missing" hyperon resonances (JLab KLF Project) on QCD thermodynamics, on freeze-out in heavy ion collisions and in the early universe, and in spectroscopy. Recent studies that compare lattice QCD calculations of thermodynamic calculations, statistical hadron resonance gas models, and ratios between measured yields of different hadron species in heavy ion collisions provide indirect evidence for the presence of "missing" resonances in all of these contexts. The aim of the workshop is to sharpen these comparisons, advance our understanding of the formation of baryons from quarks and gluons microseconds after the Big Bang and in today's experiments, and to connect these developments to experimental searches for direct, spectroscopic, evidence for these resonances. This Workshop is a successor to the recent KL2016 Workshop

**ORGANIZING COMMITTEE**

Moskov Amaryan - Chair  
ODU  
Eugene Chudakov  
JLab  
Krishna Rajagopal  
MIT  
Claudia Ratti  
University of Houston  
James Ritman, Ruhr  
U. Bochum & IKP Jülich  
Igor Strakovsky  
GWU



[WWW.JLAB.ORG/CONFERENCES/YSTAR2016/](http://WWW.JLAB.ORG/CONFERENCES/YSTAR2016/)



**HIPS 2017**

New Opportunities with High-Intensity Photon Sources

February 6-7, 2017  
Catholic University of America  
Washington, DC U.S.A.

This workshop aims at producing an optimized photon source concept with potential increase of scientific output at Jefferson Lab, and at refining the science for hadron physics experiments benefiting from such a high-intensity photon source. The workshop is dedicated to bringing together the communities directly using such sources for photo-production experiments, or for conversion into K<sub>s</sub> beams. The combination of high precision calorimetry and high intensity photon sources can provide greatly enhanced scientific benefit to (deep) exclusive processes like wide-angle and time-like Compton scattering. Potential prospects of such a high-intensity source with modern polarized targets will also be discussed. The availability of K<sub>s</sub> beams would open new avenues for hadron spectroscopy, for example for the investigations of "missing" hyperon resonances, with potential impact on QCD thermodynamics and on freeze-out both in heavy ion collisions and the early universe.

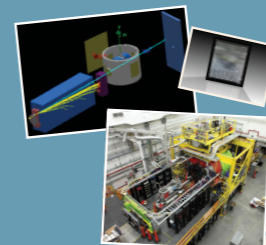

**Organizing Committee:**

Taule Horn - CUA  
Cynthia Keppel - JLab  
Carlos Munoz-Camacho - IPNO  
Igor Strakovsky - GWU



**π-K Interactions**  
*Workshop*

**ORGANIZING COMMITTEE**

Moskov Amaryan, ODU (Chair)  
U.-G. Meissner, U. Bonn/ITZ Jülich  
Curtis Meyer, CMU  
James Ritman, Ruhr-Uni-Bochum/ITZ Jülich  
Igor Strakovsky, GWU

February 14-15, 2018  
Jefferson Lab • Newport News, VA

The π-K scattering enables direct investigations of scalar and vector K\* states, including the not yet established S-wave K(800) state. These studies are also needed to get precise values of vector and scalar form factors: to independently extract CKM matrix element V<sub>us</sub> and to test the Standard Model unitarity relation in the first row of CKM matrix, to study CP violation from the Dalitz plot analysis of open charm D meson decays and in a charmless decays of B mesons in Kpiπ final states. Significant progress is made lately in Lattice QCD, in the phenomenology and in the Chiral Perturbation Theory to describe different aspects of π-K scattering. The main source of experimental data is based on experiments performed in SLAC almost five decades ago at 1970-80s. The recently proposed KL Facility incorporating the GlueX spectrometer at JLab will be able to improve the π-K scattering database by about three orders of magnitude in statistics. The workshop will discuss the necessity for and the impact of the future high statistics data obtained at JLab on π-K scattering.

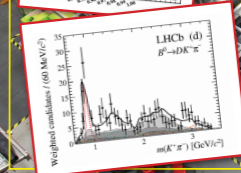
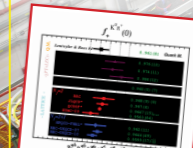
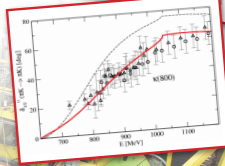
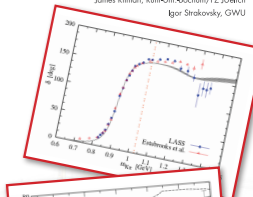

<https://www.jlab.org/conferences/pki2018/>

**KL2016**

[60 people from 10 countries, 30 talks] <https://www.jlab.org/conferences/kl2016/>  
OC: M. Amaryan, E. Chudakov, C. Meyer, M. Pennington, J. Ritman, & I. Strakovsky

**YSTAR2016**

[71 people from 11 countries, 27 talks] <https://www.jlab.org/conferences/YSTAR2016/>  
OC: M. Amaryan, E. Chudakov, K. Rajagopal, C. Ratti, J. Ritman, & I. Strakovsky

**HIPS2017**

[43 people from 4 countries, 19 talks] <https://www.jlab.org/conferences/HIPS2017/>  
OC: T. Horn, C. Keppel, C. Munoz-Camacho, & I. Strakovsky

**PKI2018**

[48 people from 9 countries, 27 talks] <http://www.jlab.org/conferences/pki2018/>  
OC: M. Amaryan, U.-G. Meissner, C. Meyer, J. Ritman, & I. Strakovsky

**In total: 222 participants & 103 talks**

**Proposal:**  
**200 Members**  
**61 Institutions**  
**20 Countries**

A. Ali<sup>18</sup>, M. B. Ali<sup>47</sup>, M. J. Amaryan<sup>45,\*†</sup>, E. G. Anassontzis<sup>2</sup>, A. V. Anisovich<sup>4,48</sup>,  
A. Austregesilo<sup>30</sup>, M. Baalouch<sup>45</sup>, F. Barbosa<sup>30</sup>, J. Barlow<sup>13</sup>, A. Barnes<sup>7</sup>, E. Barriga<sup>13</sup>,  
M. Bashkanov<sup>10,†</sup>, A. Bazavov<sup>39</sup>, T. D. Beattie<sup>50</sup>, R. Bellwied<sup>20</sup>, V. V. Berdnikov<sup>8</sup>, V. Bernard<sup>46</sup>,  
T. Black<sup>42</sup>, W. Boeglin<sup>12</sup>, M. Boer<sup>8</sup>, W. J. Briscoe<sup>14</sup>, T. Britton<sup>30</sup>, W. K. Brooks<sup>53</sup>, B. E. Cannon<sup>13</sup>,  
N. Cao<sup>22</sup>, E. Chudakov<sup>30</sup>, G. Colangelo<sup>3</sup>, P. L. Cole<sup>21</sup>, S. Cole<sup>1</sup>, O. Cortes-Becerra<sup>14</sup>, V. Crede<sup>13</sup>,  
M. M. Dalton<sup>30</sup>, T. Daniels<sup>42</sup>, D. Day<sup>58</sup>, P. Degtyarenko<sup>30</sup>, A. Deur<sup>30</sup>, S. Dobbs<sup>13</sup>, G. Dodge<sup>45</sup>,  
A. G. Dolgolenko<sup>27</sup>, M. Döring<sup>14,30</sup>, M. Dugger<sup>1</sup>, R. Dzhygadlo<sup>18</sup>, S. Eidelman<sup>5,44</sup>, R. Edwards<sup>30</sup>,  
H. Egiyan<sup>30</sup>, A. Ernst<sup>13</sup>, A. Eskandarian<sup>14</sup>, P. Eugenio<sup>13</sup>, C. Fanelli<sup>36</sup>, S. Fegan<sup>14</sup>, A. Filippi<sup>25</sup>,  
A. M. Foda<sup>50</sup>, J. Frye<sup>23</sup>, S. Furletov<sup>30</sup>, L. Gan<sup>42</sup>, A. Gasparyan<sup>41</sup>, G. Gavalian<sup>30</sup>,  
M. Gauzshtein<sup>54,55</sup>, N. Gevorgyan<sup>61</sup>, C. Gleason<sup>23</sup>, D. I. Glazier<sup>17</sup>, J. Goity<sup>30,19</sup>,  
V. S. Goryachev<sup>27</sup>, K. Götzen<sup>18</sup>, A. Goncalves<sup>13</sup>, L. Guo<sup>12</sup>, H. Haberzettl<sup>14</sup>,  
M. Hadžimehmedović<sup>57</sup>, H. Hakobyan<sup>53</sup>, A. Hamdi<sup>18</sup>, S. Han<sup>60</sup>, J. Hardin<sup>36</sup>, A. Hayrapetyan<sup>16</sup>,  
G. M. Huber<sup>50</sup>, A. Hurley<sup>59</sup>, C. E. Hyde<sup>45</sup>, T. Horn<sup>8</sup>, D. G. Ireland<sup>17</sup>, M. Ito<sup>30</sup>, R. Jaffe<sup>36</sup>,  
N. Jarvis<sup>7</sup>, R. T. Jones<sup>9</sup>, V. Kakoyan<sup>61</sup>, G. Kalicy<sup>8</sup>, M. Kamel<sup>12</sup>, C. D. Keith<sup>30</sup>, C. W. Kim<sup>14</sup>,  
F. J. Klein<sup>14</sup>, B. Z. Kopeliovich<sup>53</sup>, C. Kourkoumeli<sup>2</sup>, G. Krafft<sup>30</sup>, S. Kuleshov<sup>53</sup>, I. Kuznetsov<sup>54,55</sup>,  
A. B. Laptev<sup>33</sup>, I. Larin<sup>35</sup>, D. Lawrence<sup>30</sup>, D. I. Lersch<sup>13</sup>, H. Leutwyler<sup>3</sup>, M. Levillain<sup>41</sup>, H. Li<sup>7</sup>,  
W. Li<sup>59</sup>, K. Livingston<sup>17</sup>, B. Liu<sup>22</sup>, G. J. Lolos<sup>50</sup>, V. E. Lyubovitskij<sup>56,54,55,53</sup>, D. Mack<sup>30</sup>,  
M. Mai<sup>14</sup>, D. M. Manley<sup>31</sup>, M. Mazouz<sup>47</sup>, H. Marukyan<sup>61</sup>, V. Mathieu<sup>30</sup>, M. Matveev<sup>48</sup>,  
V. Matveev<sup>27</sup>, M. McCaughan<sup>30</sup>, W. McGinley<sup>7</sup>, M. McCracken<sup>7</sup>, J. McIntyre<sup>9</sup>,  
U.-G. Meißner<sup>4,29</sup>, C. A. Meyer<sup>7</sup>, R. Miskimen<sup>35</sup>, R. E. Mitchell<sup>23</sup>, F. Mokaya<sup>9</sup>, V. Mokeev<sup>30</sup>,  
C. Morningstar<sup>7</sup>, B. Moussallam<sup>46</sup>, F. Nerling<sup>18</sup>, K. Nakayama<sup>15</sup>, Y. Oh<sup>32</sup>, R. Omerović<sup>57</sup>,  
H. Osmanović<sup>57</sup>, A. Ostrovidov<sup>13</sup>, Z. Papandreou<sup>50</sup>, K. Park<sup>30</sup>, E. Pasyuk<sup>30</sup>, M. Patsyuk<sup>36</sup>,  
P. Pauli<sup>17</sup>, R. Pedroni<sup>41</sup>, J. R. Pelaez<sup>34</sup>, L. Pentchev<sup>30</sup>, K. J. Peters<sup>18</sup>, W. Phelps<sup>14</sup>, A. Pilloni<sup>30</sup>,  
E. Pooser<sup>30</sup>, J. W. Price<sup>6</sup>, N. Qin<sup>43</sup>, J. Reinhold<sup>12</sup>, D. Richards<sup>30</sup>, D.-O. Riska<sup>11</sup>, B. Ritchie<sup>1</sup>,  
J. Ritman<sup>51,28,†</sup>, L. Robison<sup>43</sup>, A. Rodas<sup>34</sup>, D. Romanov<sup>37</sup>, C. Romero<sup>53</sup>, J. Ruiz de Elvira<sup>3</sup>,  
H-Y. Ryu<sup>49</sup>, C. Salgado<sup>40</sup>, E. Santopinto<sup>24</sup>, A. V. Sarantsev<sup>4,48</sup>, T. Satogata<sup>30</sup>, A. M. Schertz<sup>59</sup>,  
R. A. Schumacher<sup>7</sup>, C. Schwarz<sup>18</sup>, J. Schwiening<sup>18</sup>, A. Yu. Semenov<sup>50</sup>, I. A. Semenova<sup>50</sup>,  
K. K. Seth<sup>43</sup>, X. Shen<sup>22</sup>, M. R. Shepherd<sup>23</sup>, E. S. Smith<sup>30</sup>, D. I. Sober<sup>8</sup>, D. Sokhan<sup>17</sup>, A. Somov<sup>30</sup>,  
S. Somov<sup>37</sup>, O. Soto<sup>53</sup>, M. Staib<sup>7</sup>, J. Stahov<sup>57</sup>, J. R. Stevens<sup>59,†</sup>, I. I. Strakovsky<sup>14,†</sup>, A. Švarc<sup>52</sup>,  
A. Szczepaniak<sup>23,30</sup>, V. Tarasov<sup>27</sup>, S. Taylor<sup>30</sup>, A. Teymurazyan<sup>50</sup>, A. Trabelsi<sup>47</sup>, G. Vasileiadis<sup>2</sup>,  
D. Watts<sup>10</sup>, D. Werthmüller<sup>17</sup>, T. Whitlatch<sup>30</sup>, N. Wickramaarachchi<sup>45</sup>, M. Williams<sup>36</sup>,  
B. Wojtsekhowski<sup>30</sup>, R. L. Workman<sup>14</sup>, T. Xiao<sup>43</sup>, Y. Yang<sup>36</sup>, N. Zachariou<sup>10</sup>, J. Zarling<sup>23</sup>,  
J. Zhang<sup>58</sup>, Z. Zhang<sup>60</sup>, G. Zhao<sup>22</sup>, B. Zou<sup>26</sup>, Q. Zhou<sup>22</sup>, X. Zhou<sup>60</sup>, B. Zihlmann<sup>30</sup>

# ***SUMMARY***

- **-Proposed KL Facility has a unique capability to improve existing world database up to three orders of magnitude**
- **-In Hyperon Spectroscopy**  
**PWA will allow to unravel and measure pole positions and widths of dozens of new excited hyperon states**
- **-In Strange Meson Spectroscopy**  
**PWA will allow to measure excited  $K^*$  states including scalar  $K^*(800)$  states**
- **To accomplish physics program**  
**100 days per LH2 and LD2 is required**
- **All components of KL Facility considered are feasible**  
**-With total cost of the project below \$10M**



***Thank you !***