

To: Patrizia Rossi
CC: Eugene Chudakov, Hovanes Egiyan
Subject: Response to recommendation #5 from the Hall D K-Long Facility E12-19-001
Experiment Readiness Review Phase I held at Jefferson Lab on August 2nd, 2023
Date: 27June2024

The subject recommendation reads as follows;

5. Perform time-dependent and thermal cycling (e.g. from beam trips) simulations of targets (copper and beryllium) and blockers (tungsten) that receive high (kW) power deposition to assure that thermal and mechanical performance is adequately understood. Fatigue, cracking, etc. Provide report to Physics Division management by June 2024.

CPS Copper Absorber:

Based on power absorption files supplied by Pavel Degtiarenko (using optimized geometry developed by Pavel) and converted by Hovanes Egiyan, temperatures for the CPS copper absorber were calculated using ANSYS software. 53KW is deposited into the absorber. Several iterations of cooling configurations were considered. Copper tubes will be brazed to the copper absorber forming 6 parallel cooling circuits. The convective cooling values were determined by hand calculations and verified by a simple FLUENT model. The results shown in figure 1 give a maximum localized temperature in the copper of 155C along the location of highest power deposition. A rough calculation shows it will take on the order of a second to heat to peak temperatures. The resulting thermally induced maximum equivalent stress (static) in this area is 71MPa (Fig 2). This is right around the yield strength of annealed OFHC copper. The published fatigue strength is 67MPa (based on total reverse bending and 100 million cycles). Over the life of the experiment, there will be under 100,000 cycles (based on 30 weeks/year times 2 years at 50% beam on, assuming 20 beam trips per hour). Data shows that for 10e5 cycles, the fatigue stress is around 100MPa (fig. 3). With each trip (assume 1 minute), the temperature will not have time to return to the initial temperature (assumed to be 30C). Even if it did, the cycles will not reverse stress levels thus not being as severe as the fully reversed loading .

The melting point of this material is 1083C. We will be using ½ hard copper which will have copper tubes brazed to it. During the vacuum brazing process, the material will be heated to about 700C. This will reduce the yield stress to a value somewhat above the annealed condition. Cyclic and plastic analysis was not performed as the temperatures, stresses and cycles are low enough that it is not required. No cycling issues are anticipated.

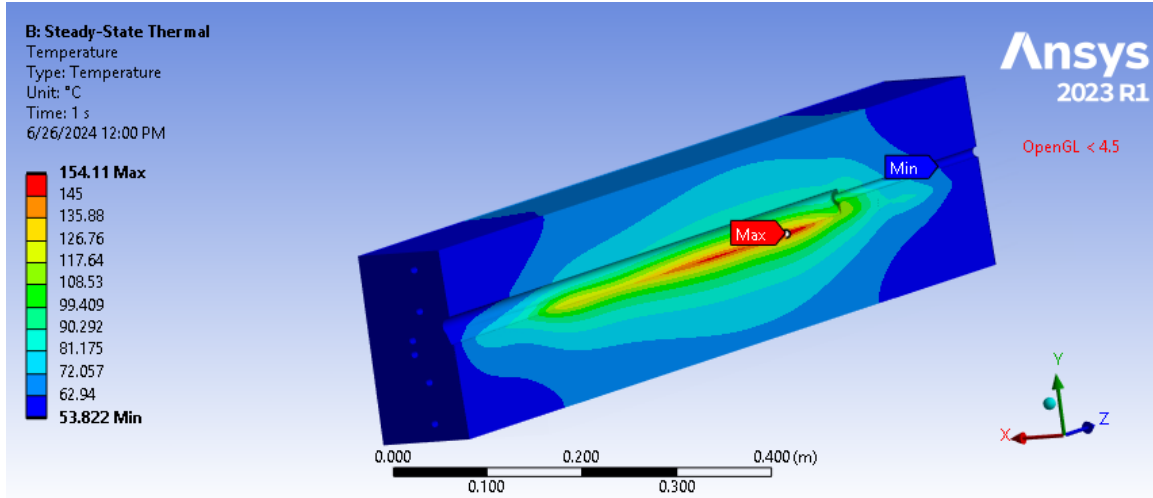

Fig. 1 CPS Copper Absorber Temperature Distribution – section cut down the middle

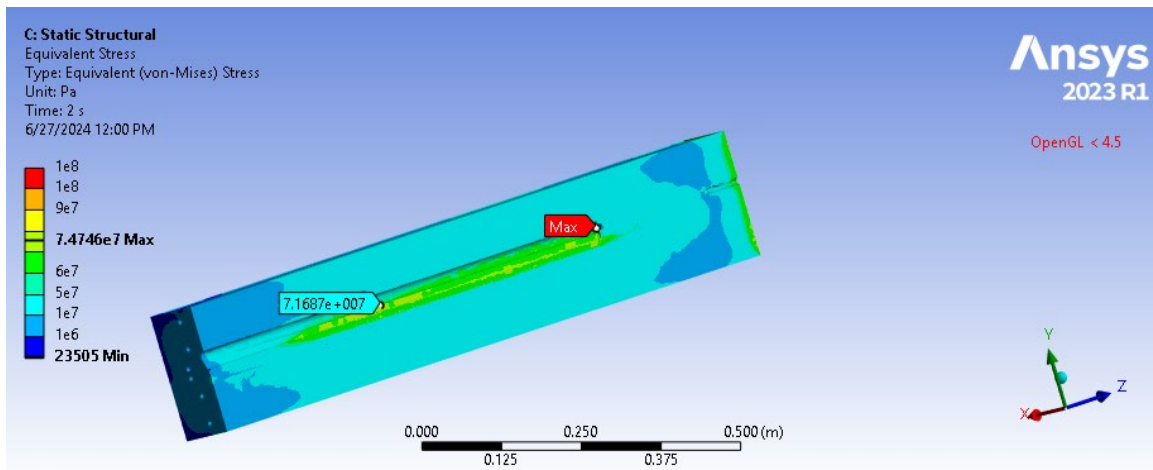

Fig. 2 CPS Copper Absorber Thermal Stresses

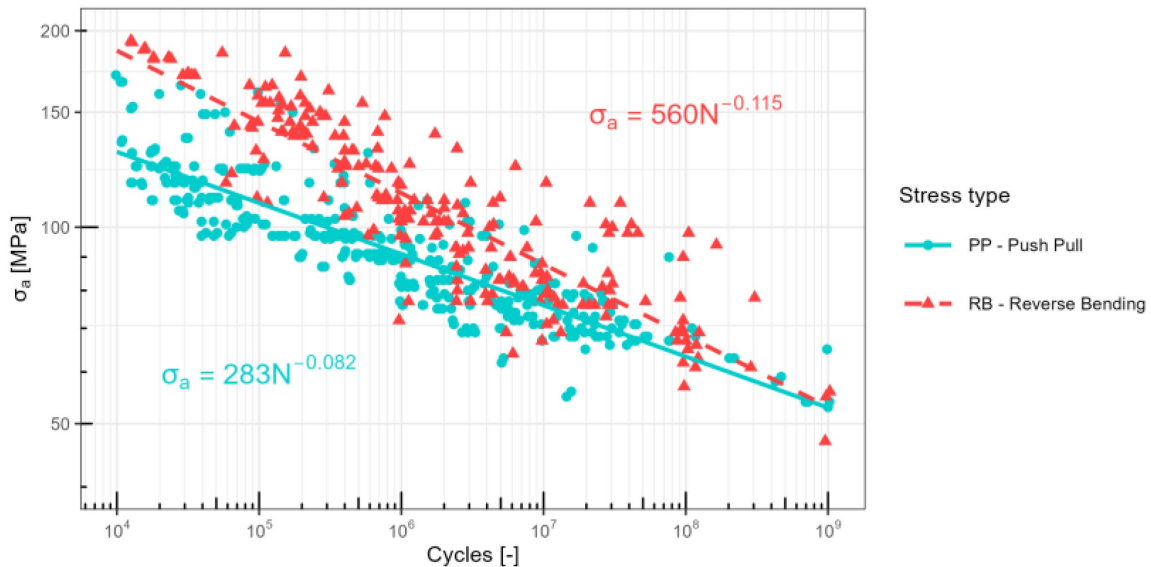

Figure 3 Fatigue curve of pure copper

KPT Tungsten Absorber:

Based on power absorption files supplied by Vitaly Baturin and Hovanes Eginyan, the temperature distribution for the KPT tungsten absorber was calculated using ANSYS software. 5.3KW is deposited into the block. Several iterations of cooling configurations were considered. Copper plates will be pressed against the outer surfaces and in turn cooled with water inside brazed copper tubes. The analysis assumes a 10um air gap between the copper plates and the tungsten. The surfaces of the tungsten and copper will be machined to a much smoother surface (32 uin Ra) for better thermal conductivity. Based on these conditions, the maximum temperature in the absorber is 232C (fig. 4). This produces 250Mpa stresses from thermal effects (fig. 5). (The 1.2GPa maximum is induced by overly constrained boundary condition at edge). The published yield strength for 95% Tungsten per ASTM-B-777 is 517Mpa minimum. The minimum melting point is 1425C. At temperatures near 300C, the surface of the tungsten will oxidize but there is no damage to the bulk material. Based on the relatively low temperatures and stresses, there are no major concerns with this material.

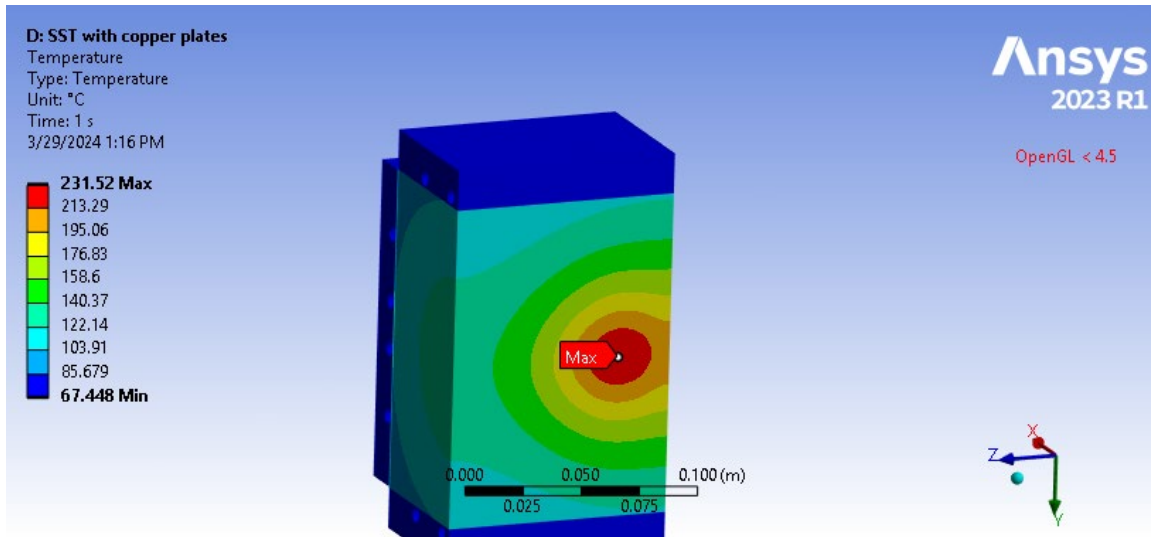

Fig. 4 KPT Tungsten Absorber Temperature Distribution

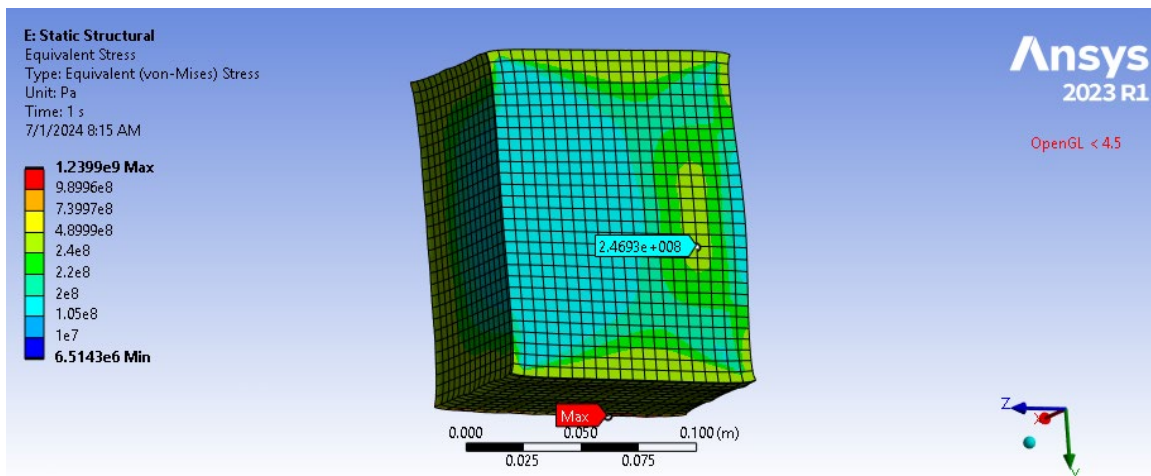

Fig. 5 KPT Tungsten Absorber Thermal Stress Distribution

KPT Beryllium Target:

Based on power absorption files supplied by Vitaly Baturin and Hovanes Eginyan, temperatures for the KPT Beryllium Target were calculated using ANSYS software. The power absorption is 204W. The target is encased in a water cooled copper shield. The analysis assumes a 100um air gap between the target and copper. The maximum temperature calculated is 56C (fig. 6). The maximum thermal stresses come out to be 130Mpa (fig. 7). The published yield strength is 241Mpa and the melting temperature is 1273C. There should be no temperature induced cyclic issues.

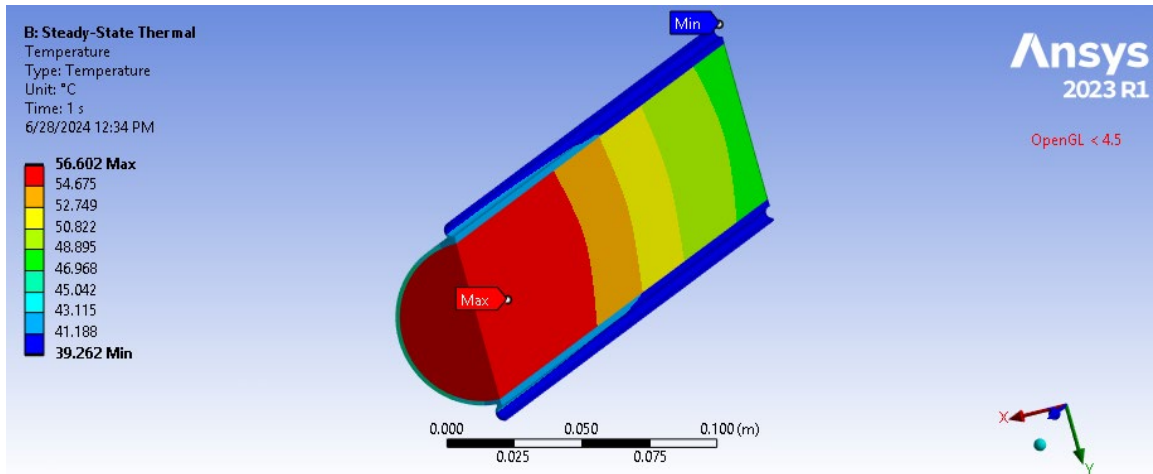

Figure 6 KPT Beryllium Target Temperature Distribution

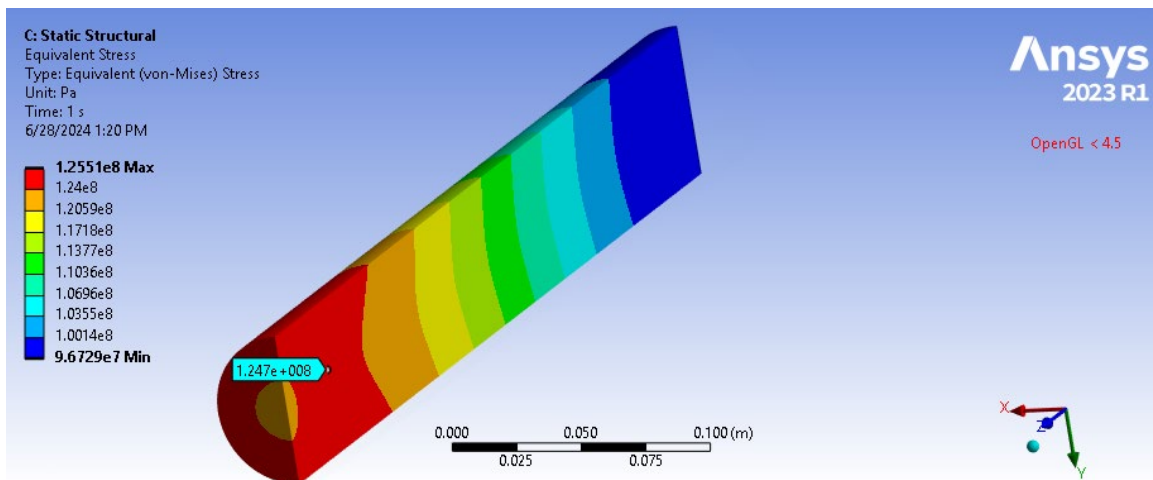

Figure 7 KPT Beryllium Target Thermally induced Stress Distribution