



UNIVERSITY
of York

K_L Flux Monitor

Mikhail Bashkanov

KLF FM Readiness questions



UNIVERSITY
of York

- What is the status of the conceptual design of the Flux Monitor (KFM)?
- If more than one option is considered please discuss each of them

KLF FM Readiness questions



- What is the status of the conceptual design of the Flux Monitor (KFM)?
→ Conceptual design is ready
- If more than one option is considered please discuss each of them

K_l flux monitor location



Be target

LH2/LD2 target

24 m

Flux Monitor

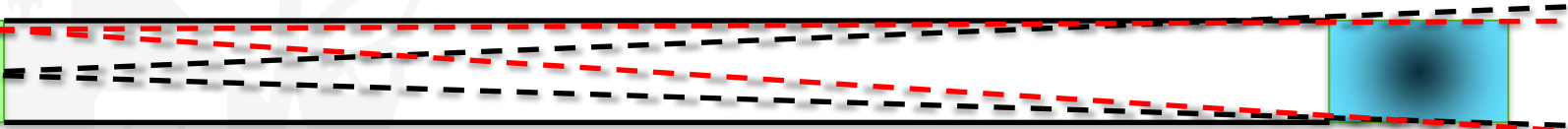

K_L decays

	Br, %
$K_L \rightarrow \pi^\pm e^\mp \nu_e$	40.55
$K_L \rightarrow \pi^\pm \mu^\mp \nu_\mu$	27.04
$K_L \rightarrow \pi^+ \pi^- \pi^0$	12.54
$K_L \rightarrow \pi^0 \pi^0 \pi^0$	19.52

- **~ 21% of kaons decays in flight**
- **Any decay with charged particles can be used**

K_L flux monitor location

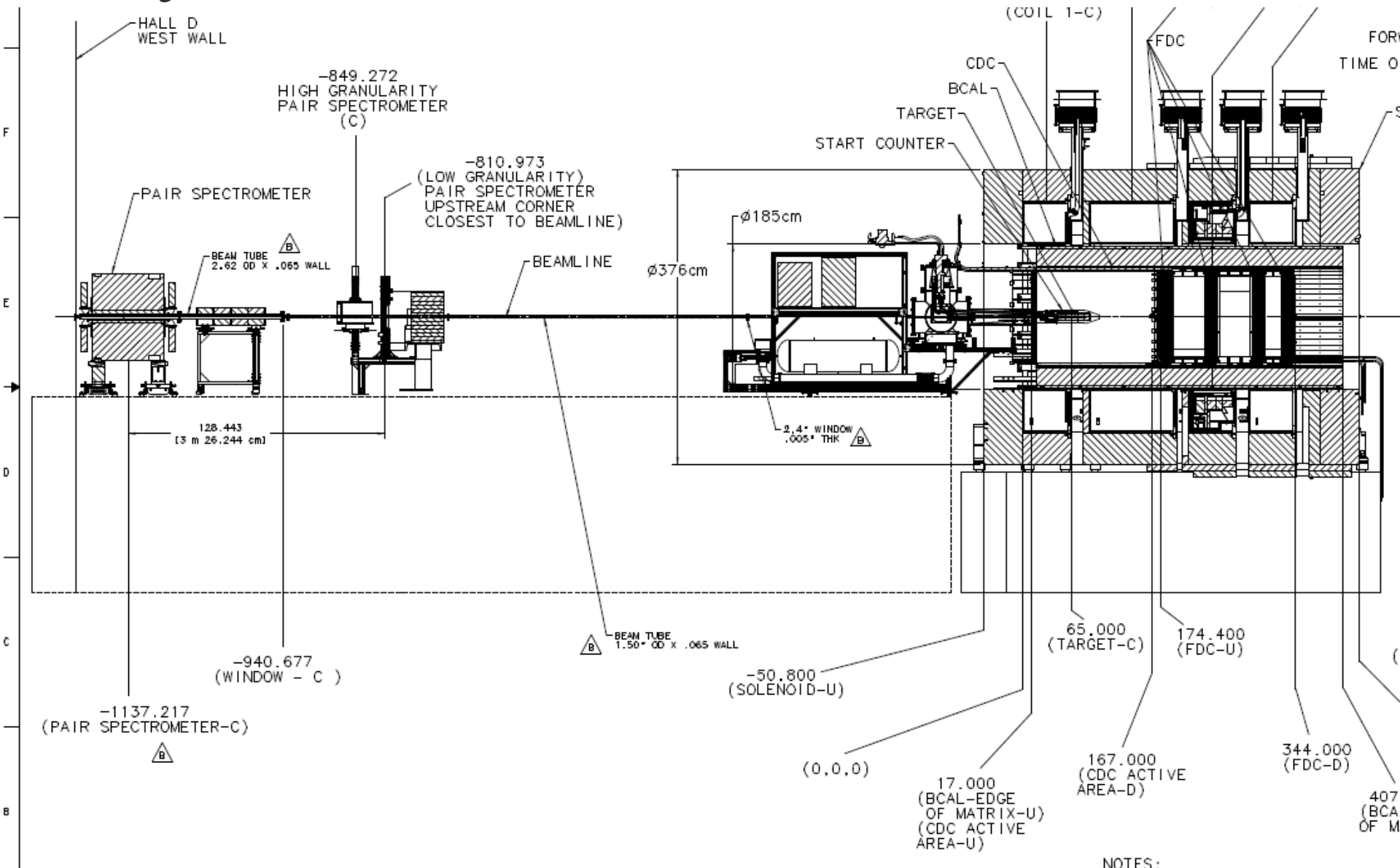

NOTES:

Flux monitor location

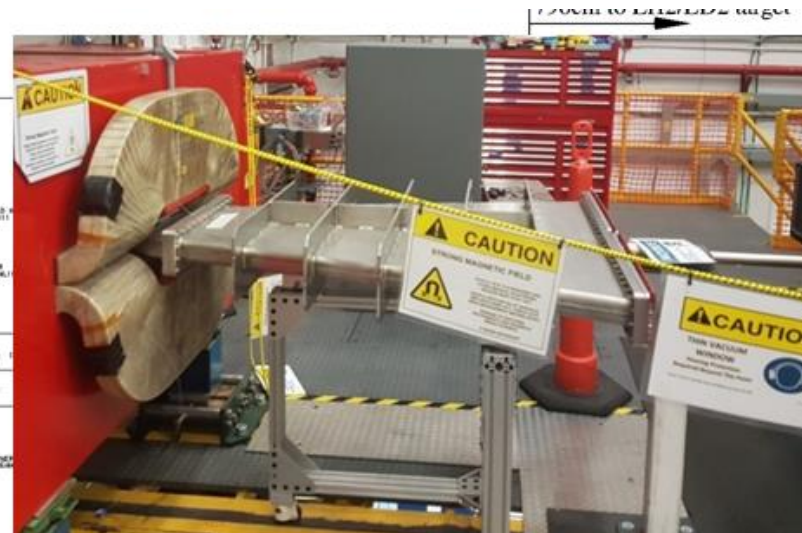
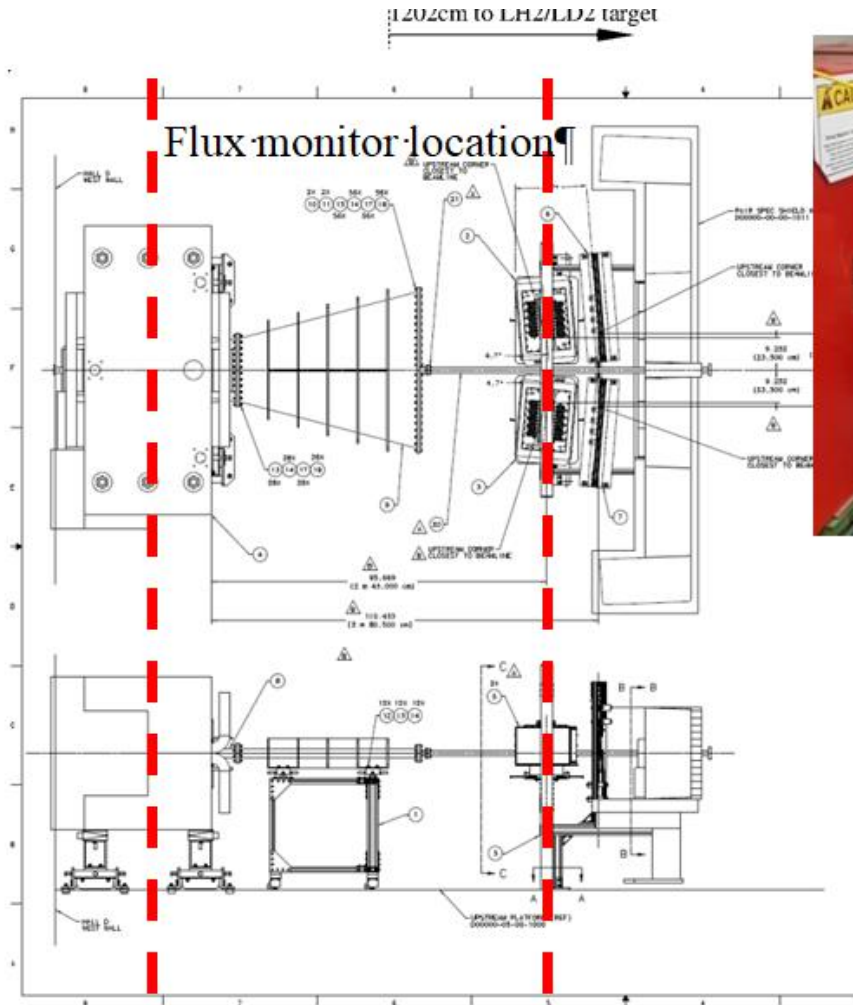

K_L monitoring

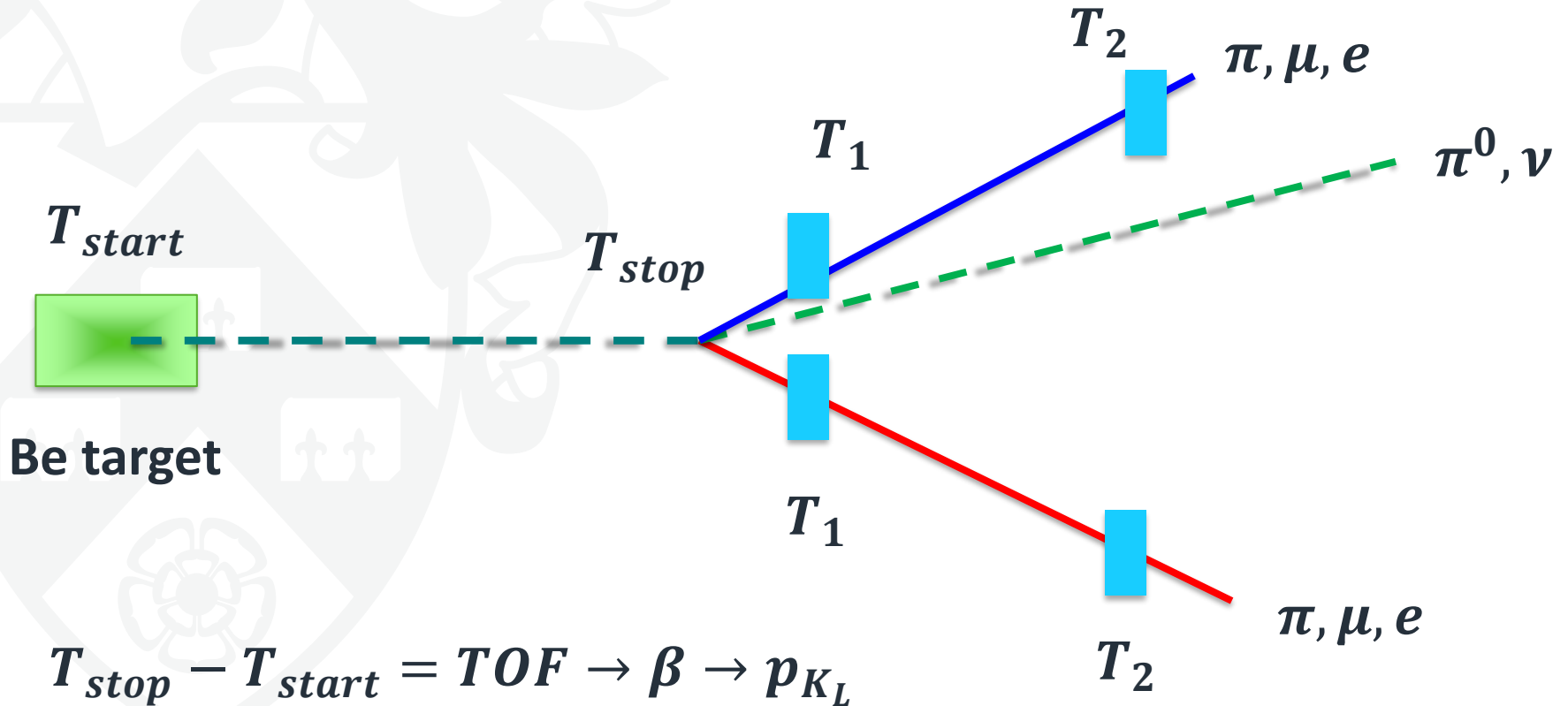



UNIVERSITY
of York

KL FM options

Option A

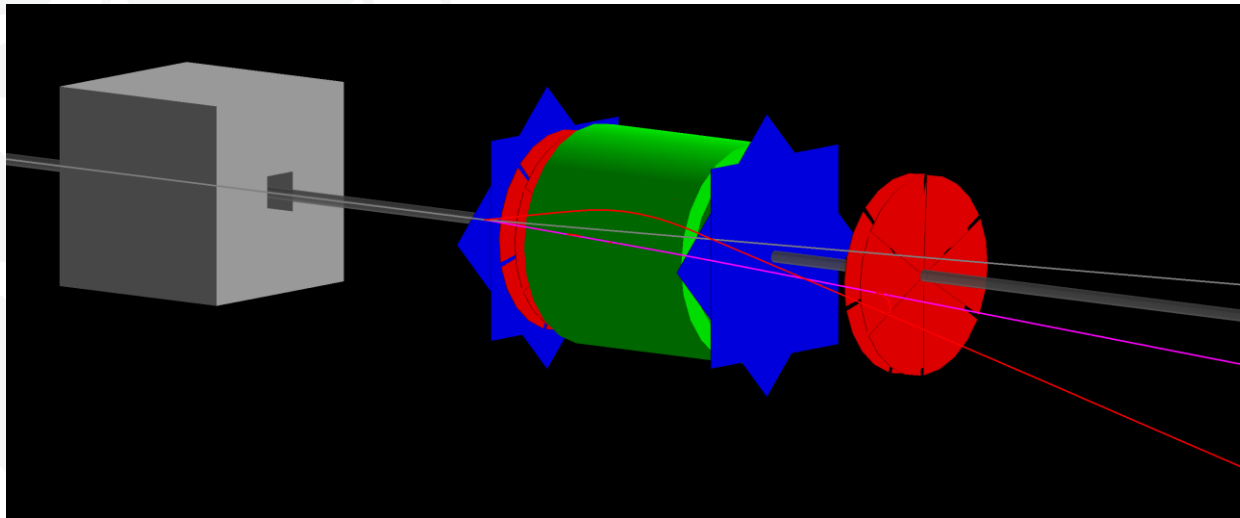

Bespoke new ToF system
Bespoke new Trackers
Bespoke new Magnet

- ⊕ Great performance
- ⊗ Expensive (~1M GBP equipment)
- ⊗ Requires a lot of man power

Option B



UNIVERSITY
of York

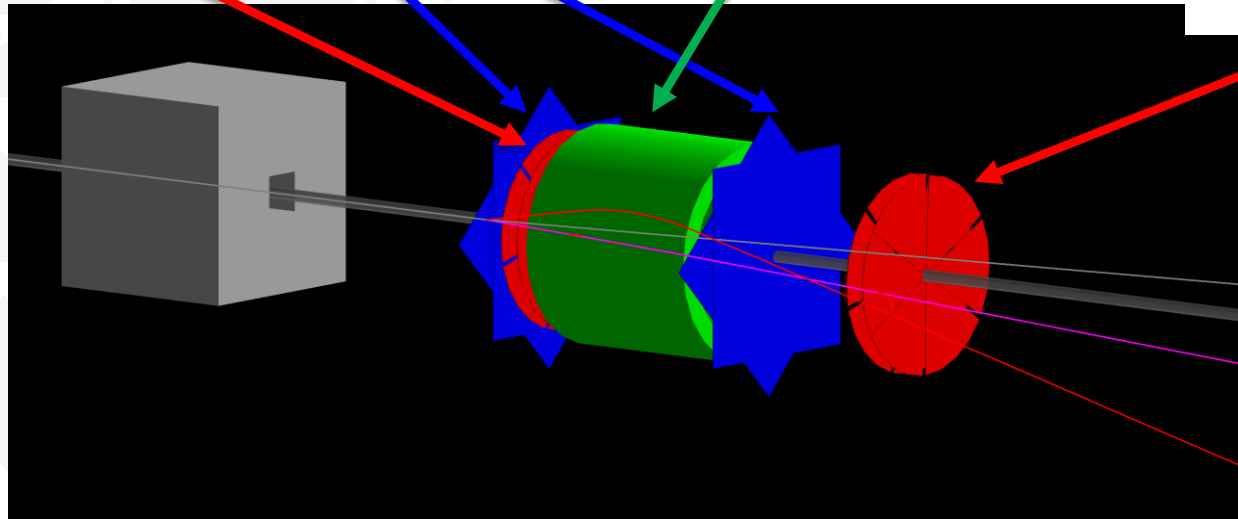
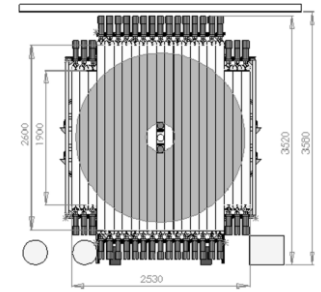
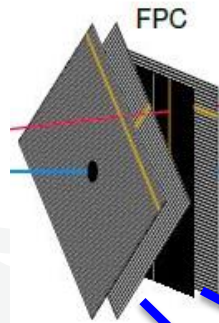
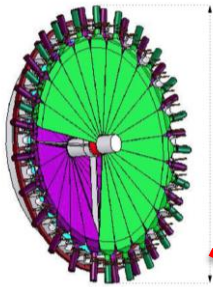

Used Wasa ToF system
Used Wasa Trackers
Used MRI Magnet

- ⊕ Great performance
- ⊕ Affordable (~150k GBP equipment)
- ⊗ Still ~100k for MRI/magnet related expenses

Option C



UNIVERSITY
of York

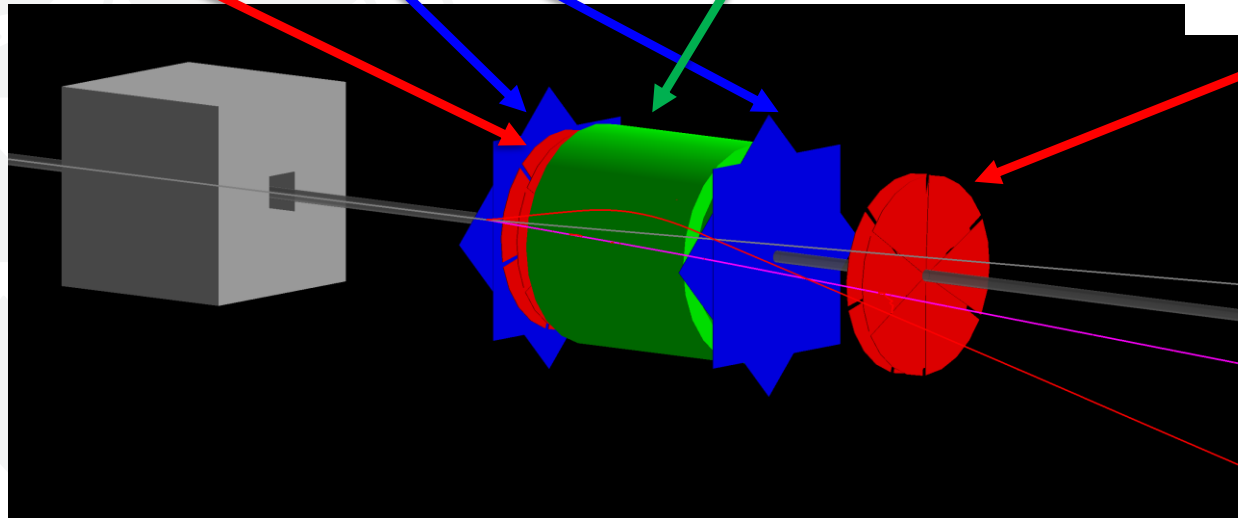
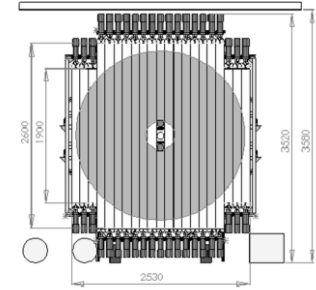
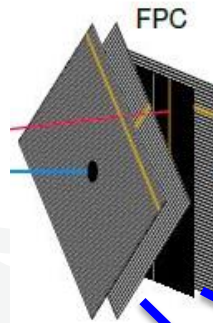
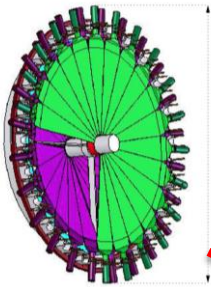

Used Wasa ToF system
Used Wasa Trackers
Used MRI Magnet

- ⊕ Great performance
- ⊕ Affordable (~150k GBP equipment)
- ⊗ Still ~100k for MRI/magnet related expenses

Option C

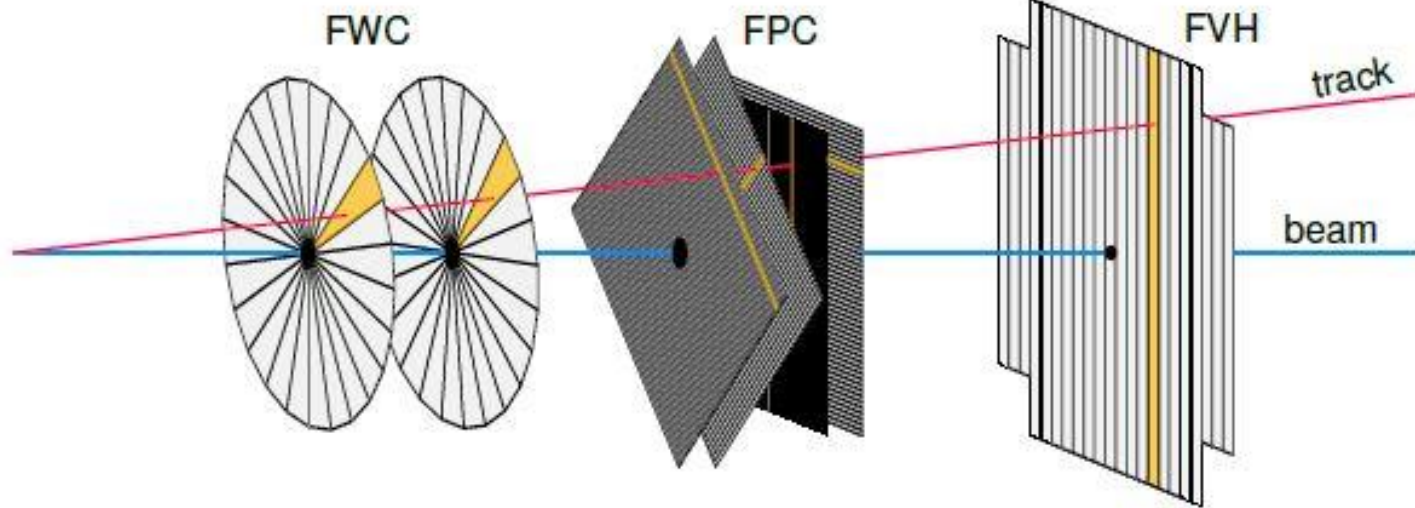

Used Wasa ToF system
Used Wasa Trackers
NO Magnet

- ⊕ Good performance
- ⊕ Cheap (~50k GBP mainly relocation)
- ⊗ Limited capabilities in rare kaon decay studies

Option D

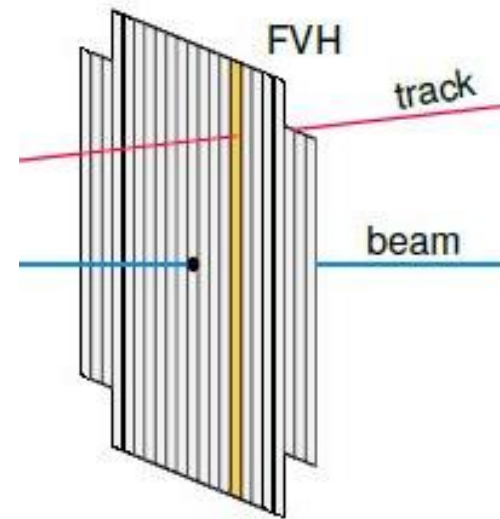
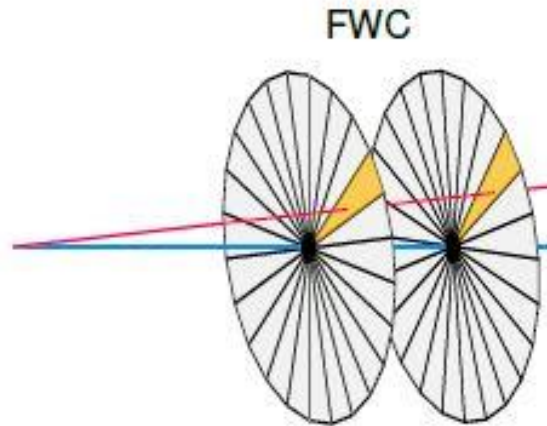

Used Wasa ToF system
NO Trackers
NO Magnet

- ⊕ Tolerable beam momentum resolution performance
- ⊕ Very Cheap (~7k GBP mainly relocation)
- ⊗ Limited capabilities
- ⊗ No beam shape reconstruction



UNIVERSITY
of York

KL FM options: C-B

Option B-C



UNIVERSITY
of York

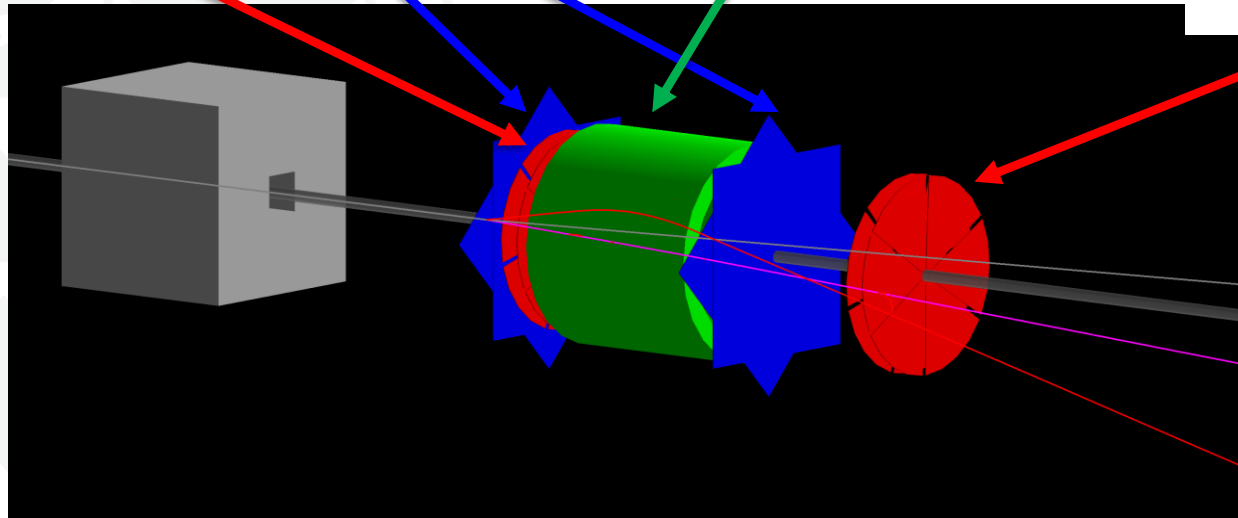
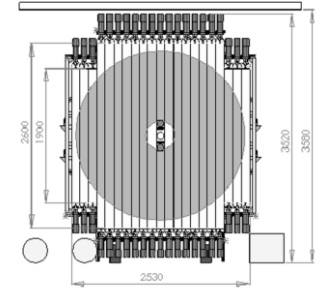
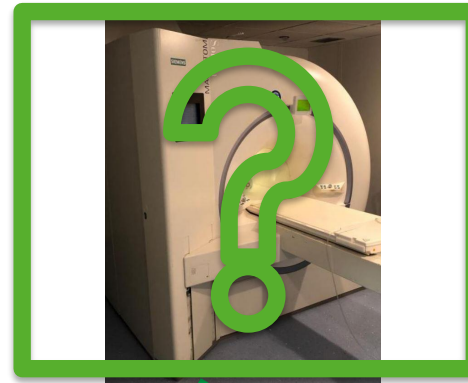
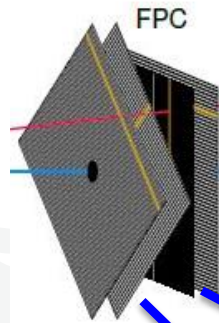
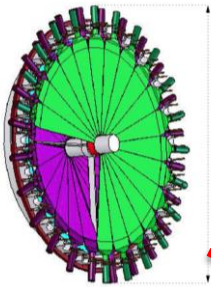

Used Wasa ToF system
Used Wasa Trackers
Used MRI Magnet?

- ⊕ Great performance
- ⊕ Affordable (~150k GBP equipment)
- ⊗ Still ~100k for MRI/magnet related expenses

Status



- Asked for 2 STFC UK grants
 - Outcome will be known by spring-summer this year
 - Quite confident (with possible exception of MRI)
- Wasa ToF
 - Co-PI Bashkanov, owner Uni Tuebingen(Germany) now in Juelich
 - Agreed on use (both Juelich and Tuebingen)
- Wasa tracker
 - owner Uni Uppsala(Sweden) now in Juelich
 - Agreed on use (both Juelich and Uppsala)
- All components can be relocated from Q4 2023

Requirements “C”

- “Feet” places for standard profiles
- Place to locate crates and tracker gas station
- Place for the MRI will be reserved and it can be installed there at any moment



KLF FM Readiness questions



- What is the status of the conceptual design of the Flux Monitor (KFM)?
 - Conceptual design is ready
- If more than one option is considered please discuss each of them
- 4 options were considered.
- A “balanced” option “C” was chosen as a solution.
- Possible extension to option “B” (adding a MRI) is possible, provided requested funding will be granted

Conclusion



UNIVERSITY
of York



Possible magnet



Siemens Magnetom 1.5T used MRI

Table 4: Magnet specification

Parameter	Siemens
RF frequency MHz	63.6
Shielding	Passive and active
Homogeneity (VRMS) 40 cm DSV ppm	0.2 (typically)
Field stability ppm/hr	< 0.1
Number of measurement planes	24
Number of measurement points	20
Cooling system	Liquid helium only
Boil-off rate l/hr	0
Helium refill	10 years maximum (approximately)

Table 7: Installation details

Overall scanner dimensions	Siemens
Mass: magnet only tonnes	3.55 ± 8 (including helium)
Mass: assembly tonnes	5.5
Depth with covers (z) cm	160
Width with covers (x) cm	230
Height with covers (y) cm	230

~70kEuro+delivery

Wasa detectors

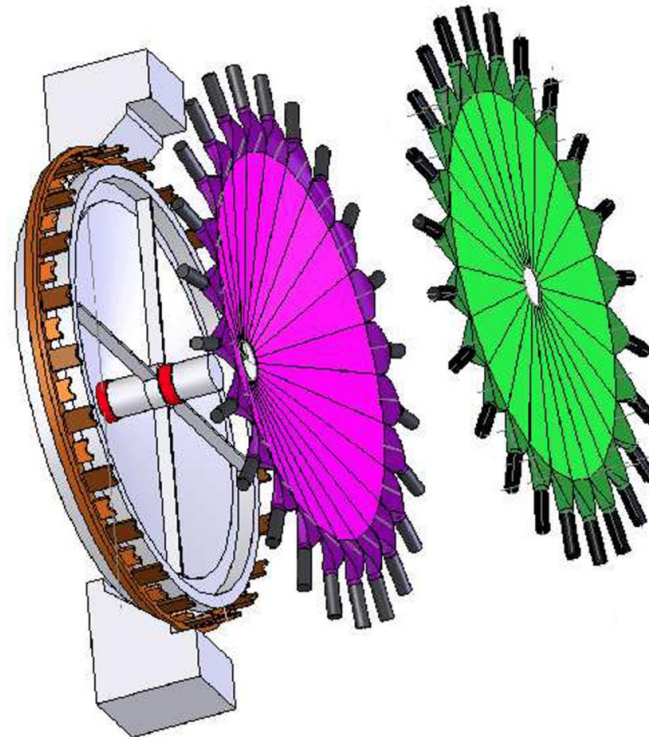
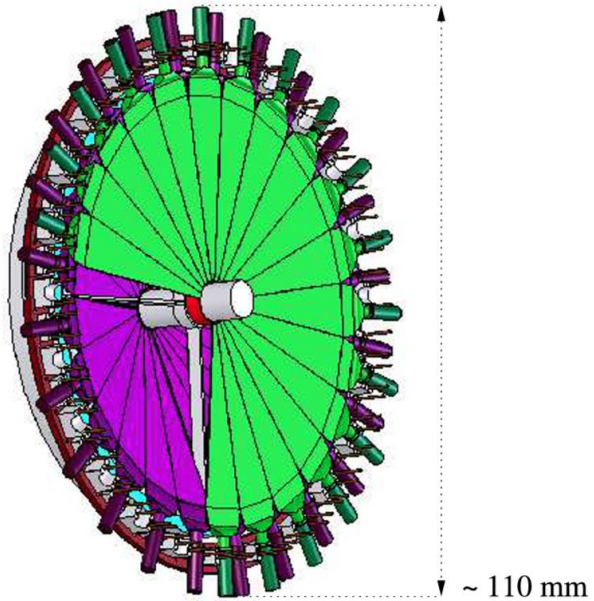

Wasa detectors

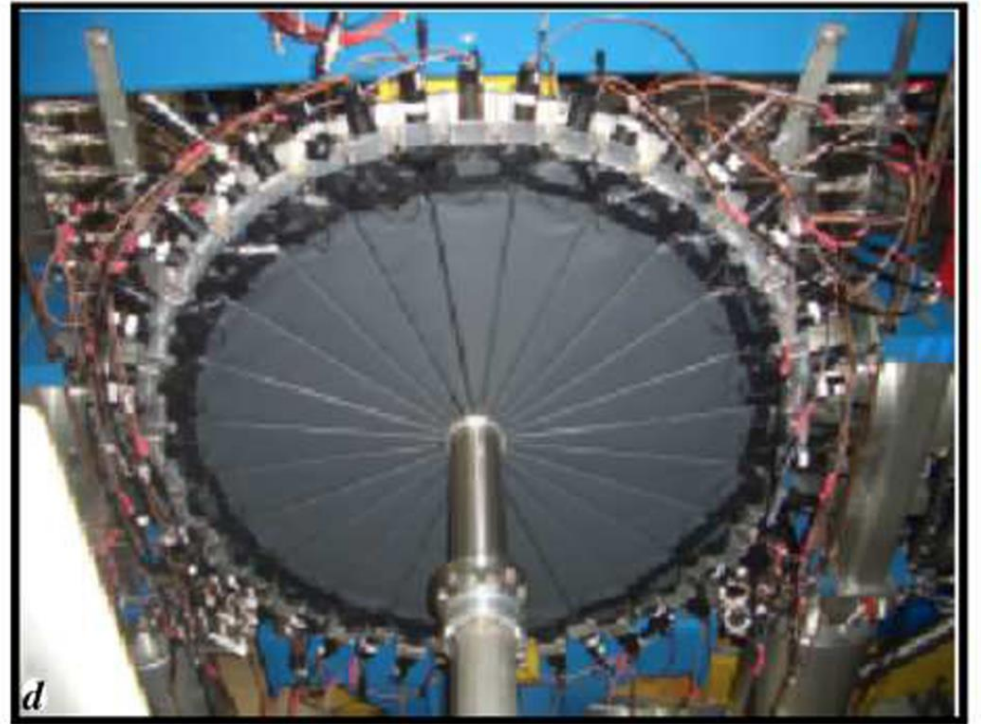
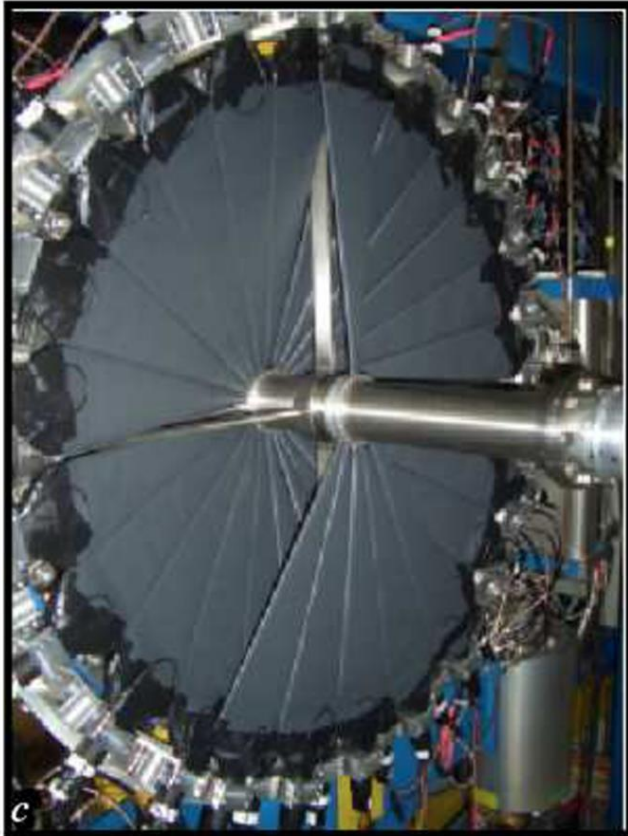

Wasa detectors

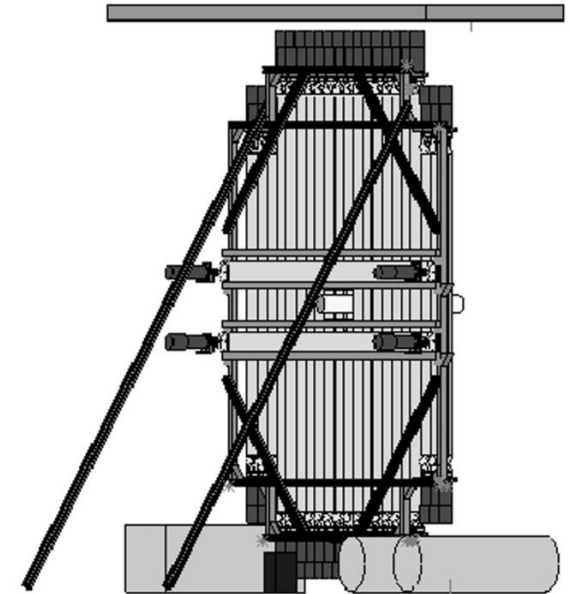
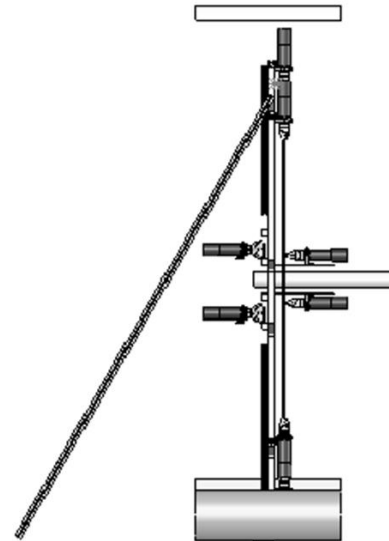
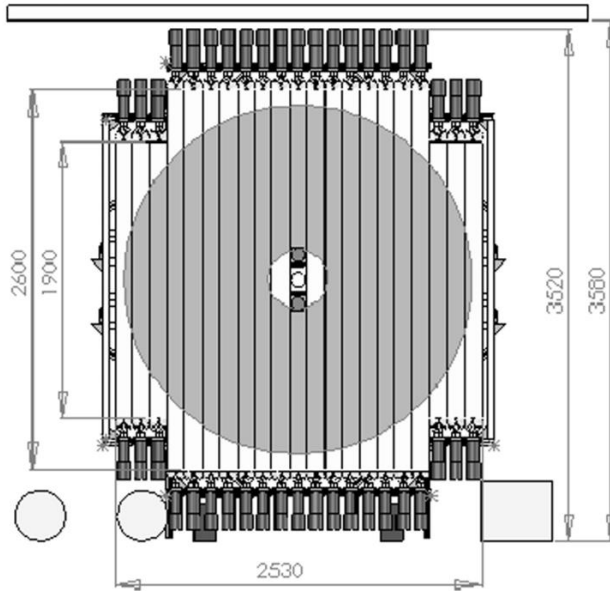

Wasa detectors

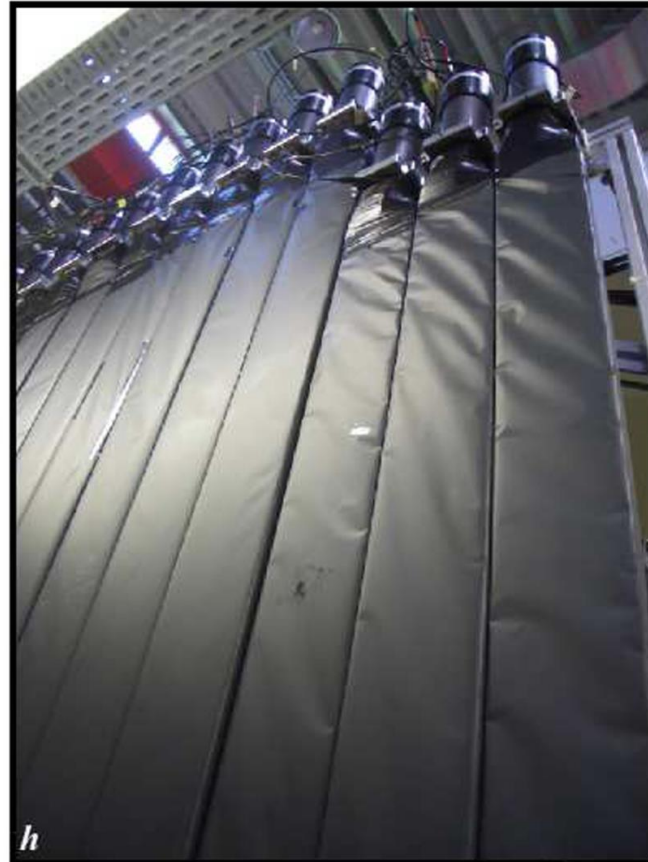

Wasa detectors

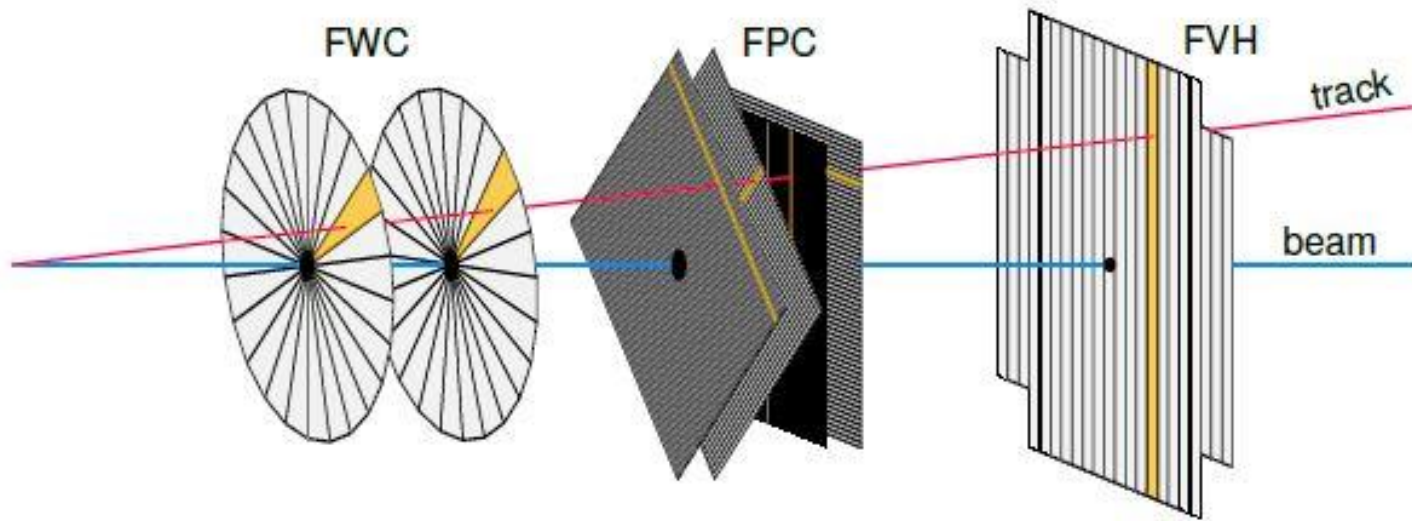

Used in TOF mode for the isospin violating $dd \rightarrow {}^4\text{He}\pi^0$ experiment

Wasa detectors

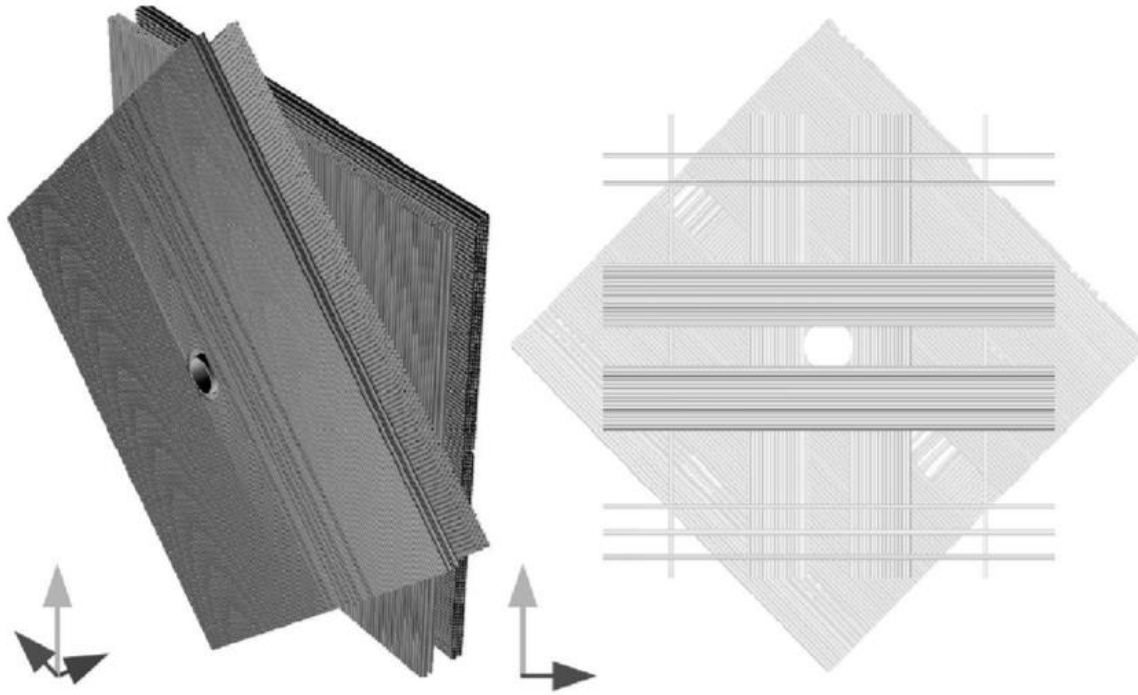

(b) *Forward Proportional Chamber FPC*

Status

- FWC (TOF start) and FVH (TOF stop)
 - Agreed on use
 - Available from Q42023
- Tracker
 - Agreed on use (Uppsala, TJ)
 - Available from Q42023

Wasa detectors

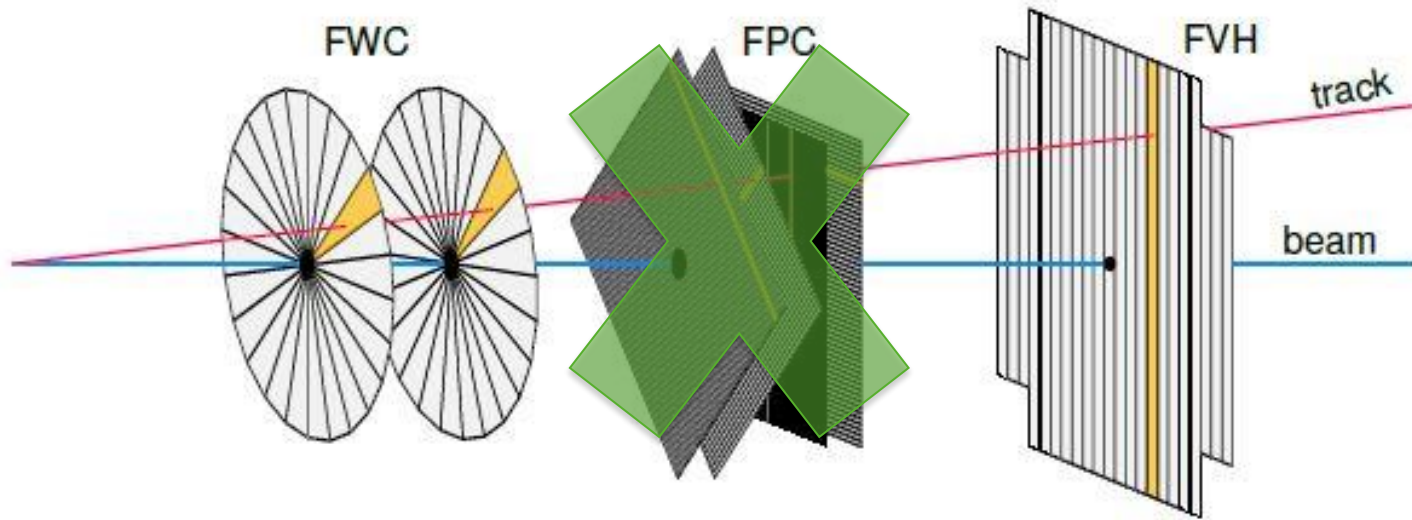

K_l time resolution due to position in Be

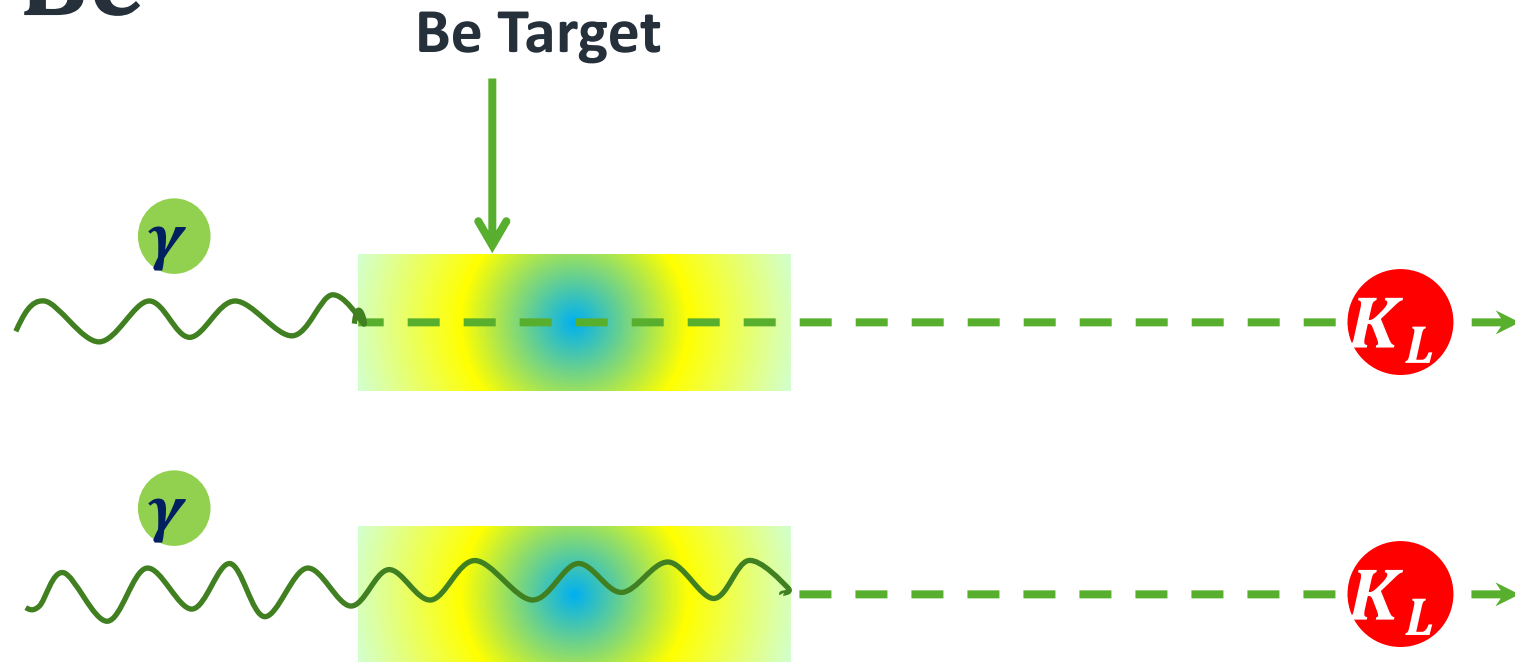

$$\Delta t = \frac{L}{c\beta_{K_l}} - \frac{L}{c} = \frac{L}{c} \left(\frac{1}{\beta_{K_l}} - 1 \right)$$

For $L=40\text{cm}$ and $p_{K_l} > 800\text{MeV}/c, \Delta t < 150\text{ps}$

K_L time resolution due to position in Re

δt vs p

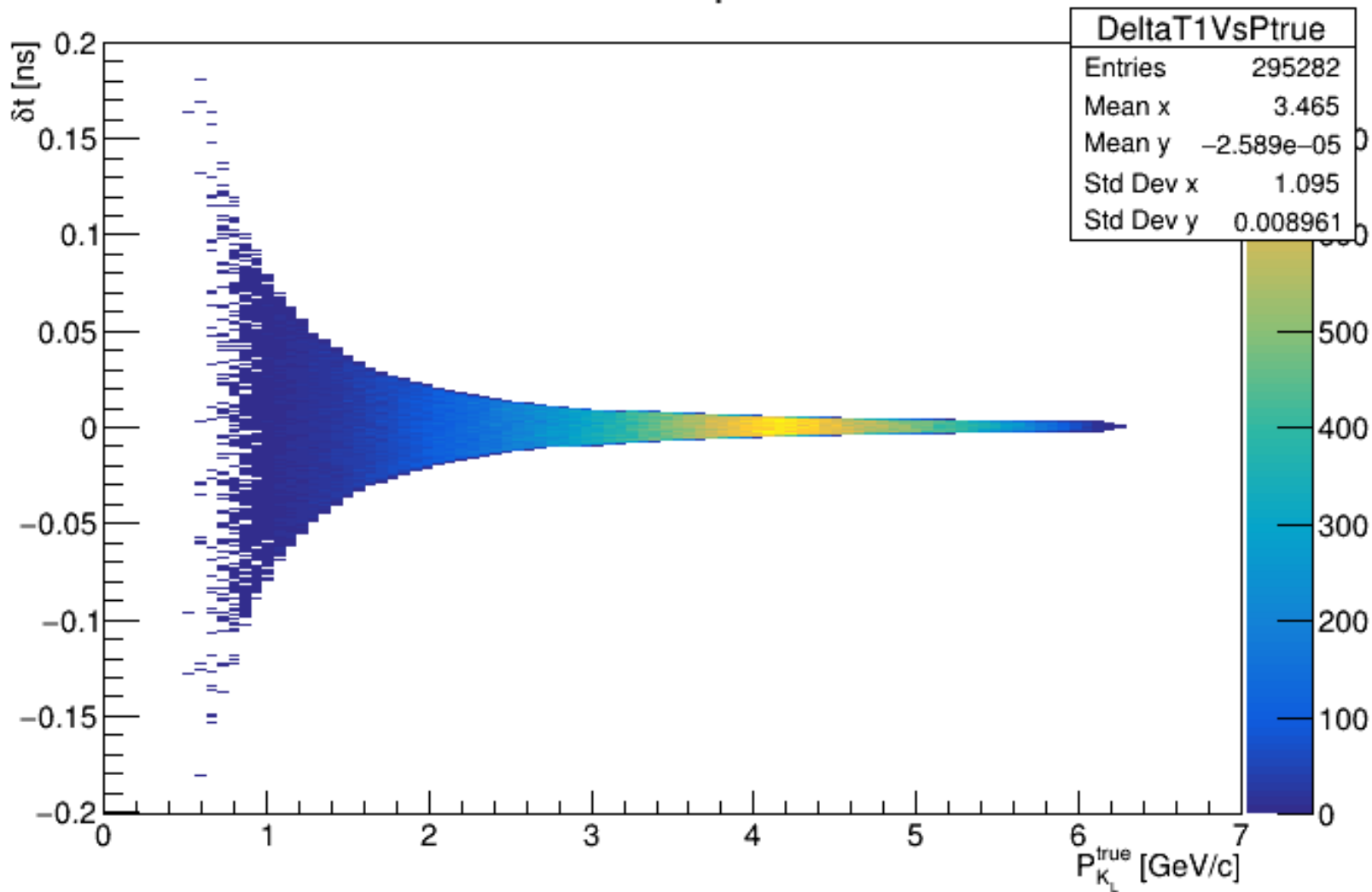

“No tracker” K_L time resolution

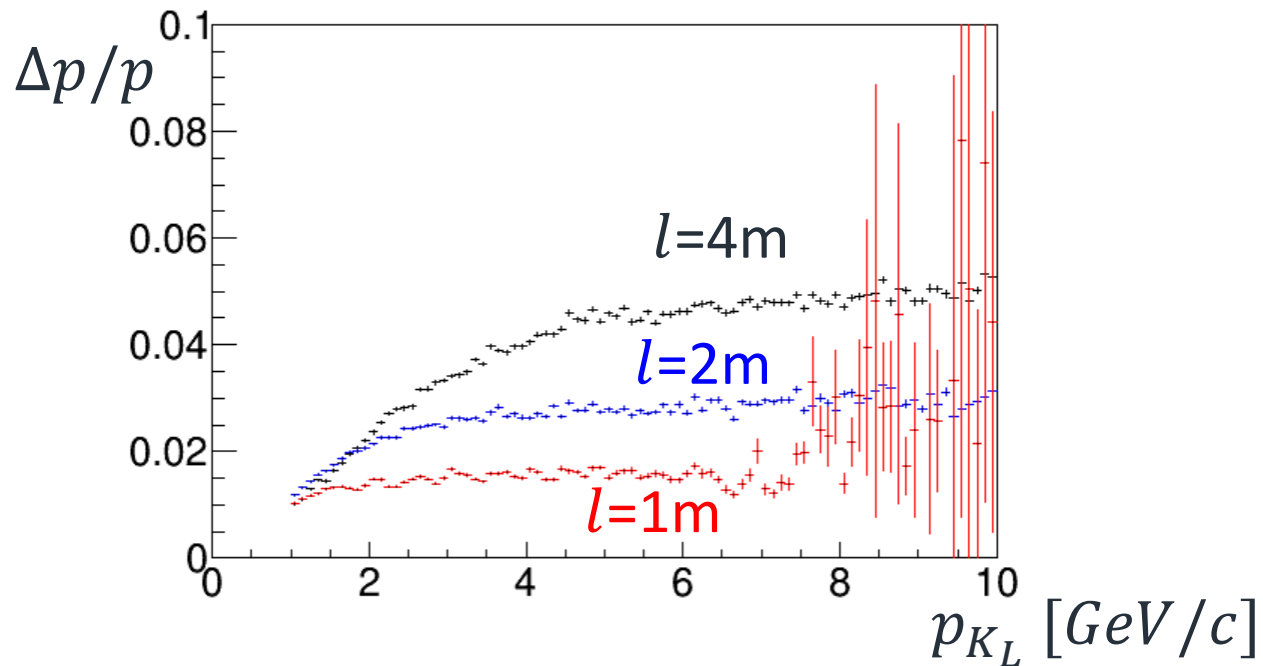
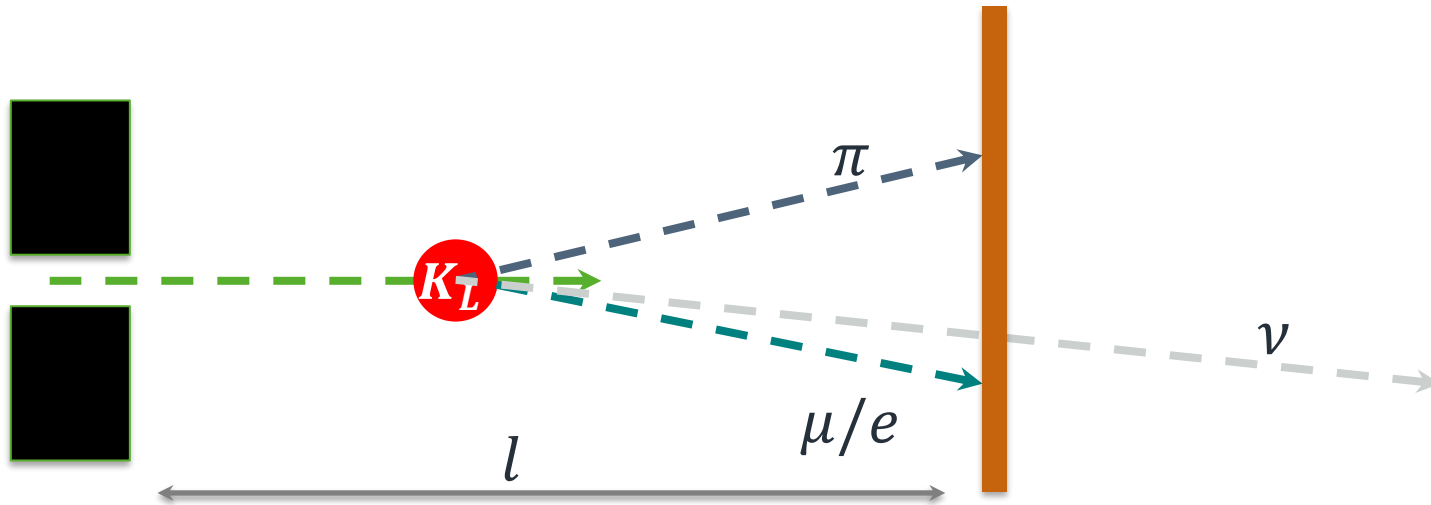

Status

- 3 options for the Flux monitor
 - Price
 - Performance
 - Byproduct research (rare decays)
 - Background suppression