

Engineering Status

K-Long in Hall D

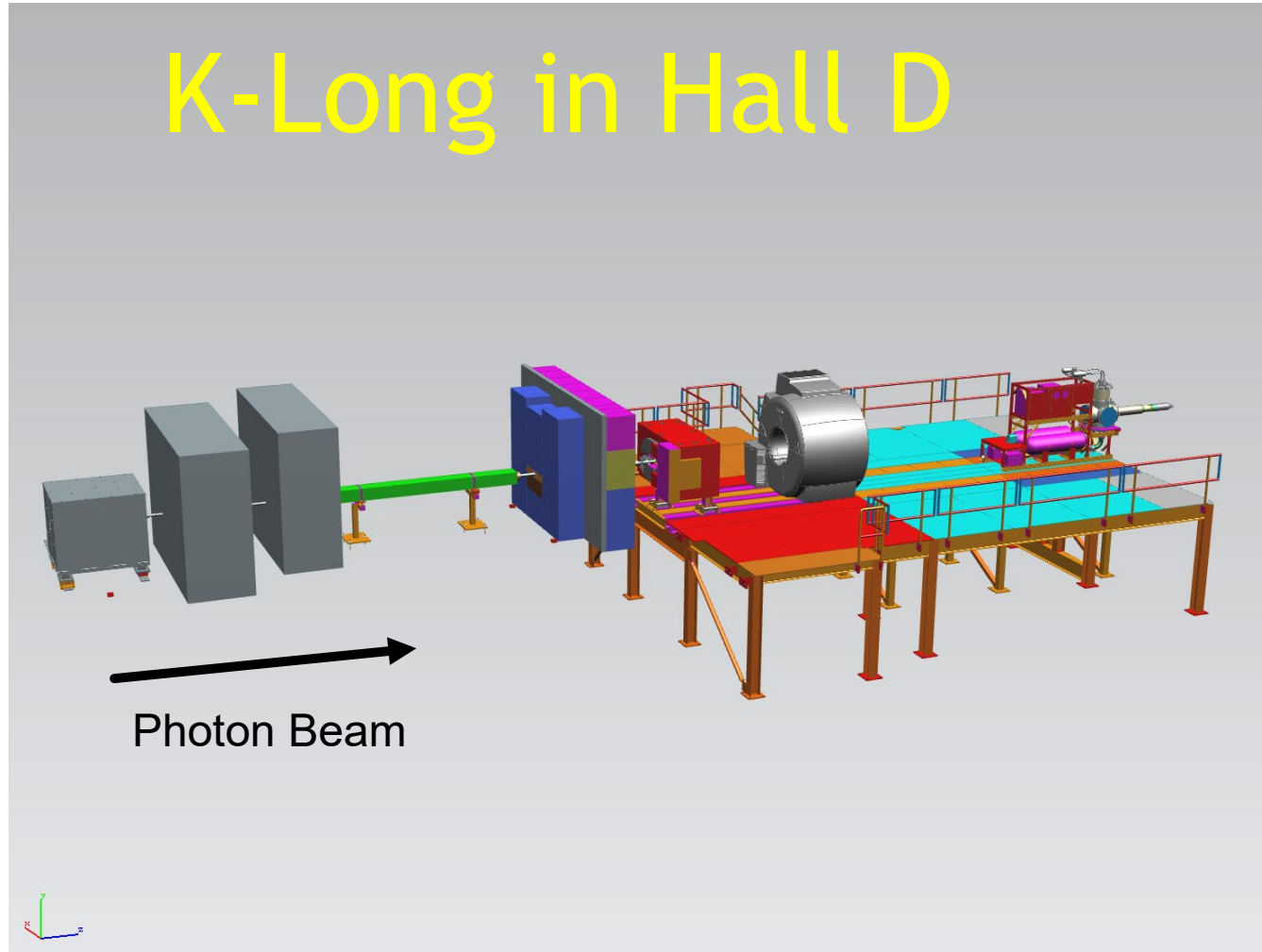

Hall D K-Long Facility ERR August 2023 - Presented by Tim Whitlatch

Topics

- ▶ KPT
 - ▶ Design Status
 - ▶ Cooling and Contamination
 - ▶ Civil Construction Requirements
 - ▶ Cost and Schedule
 - ▶ Decommissioning Plan
- ▶ CPS
 - ▶ Design Status
 - ▶ Cooling and Contamination
 - ▶ Civil Construction Requirements
 - ▶ Cost and Schedule
 - ▶ Decommissioning Plan
- ▶ Flux Monitor
 - ▶ Design Status

Hall D K-Long Facility ERR August 2023 - Presented
by Tim Whitlatch

Hall D Collimator Cave Layout for KPT

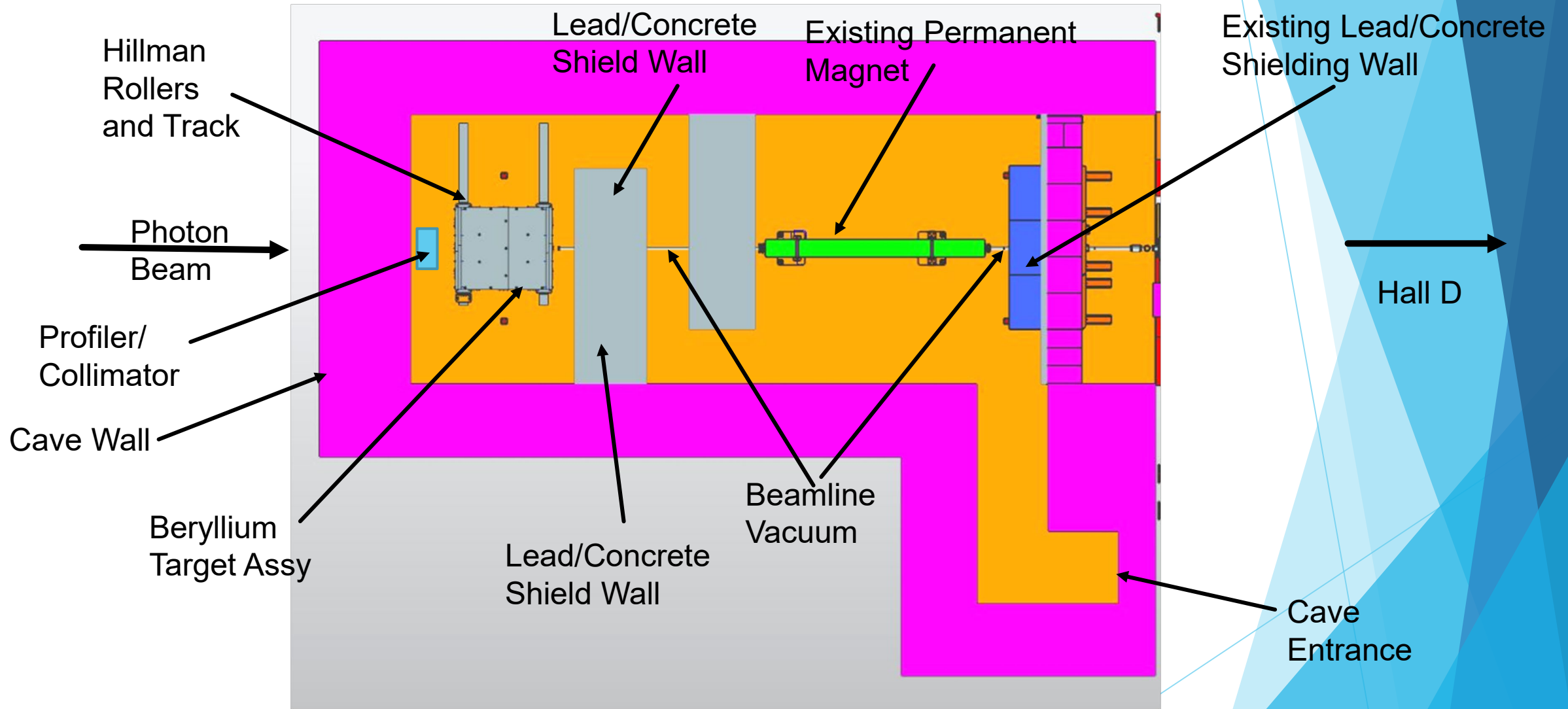

Hall D K-Long Facility ERR August 2023 -
Presented by Tim Whitlatch

Beryllium Target Assy

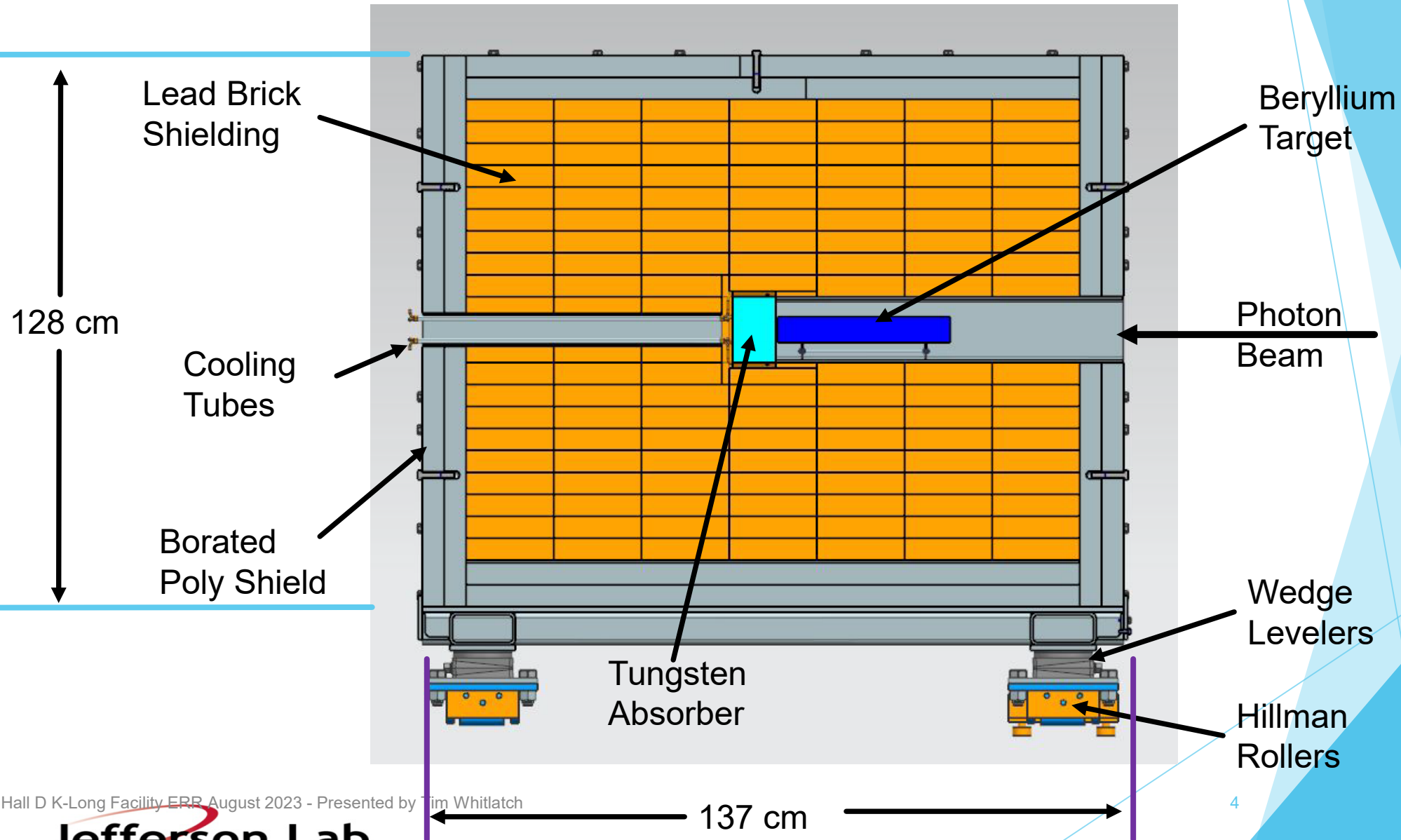

Beryllium Target Section

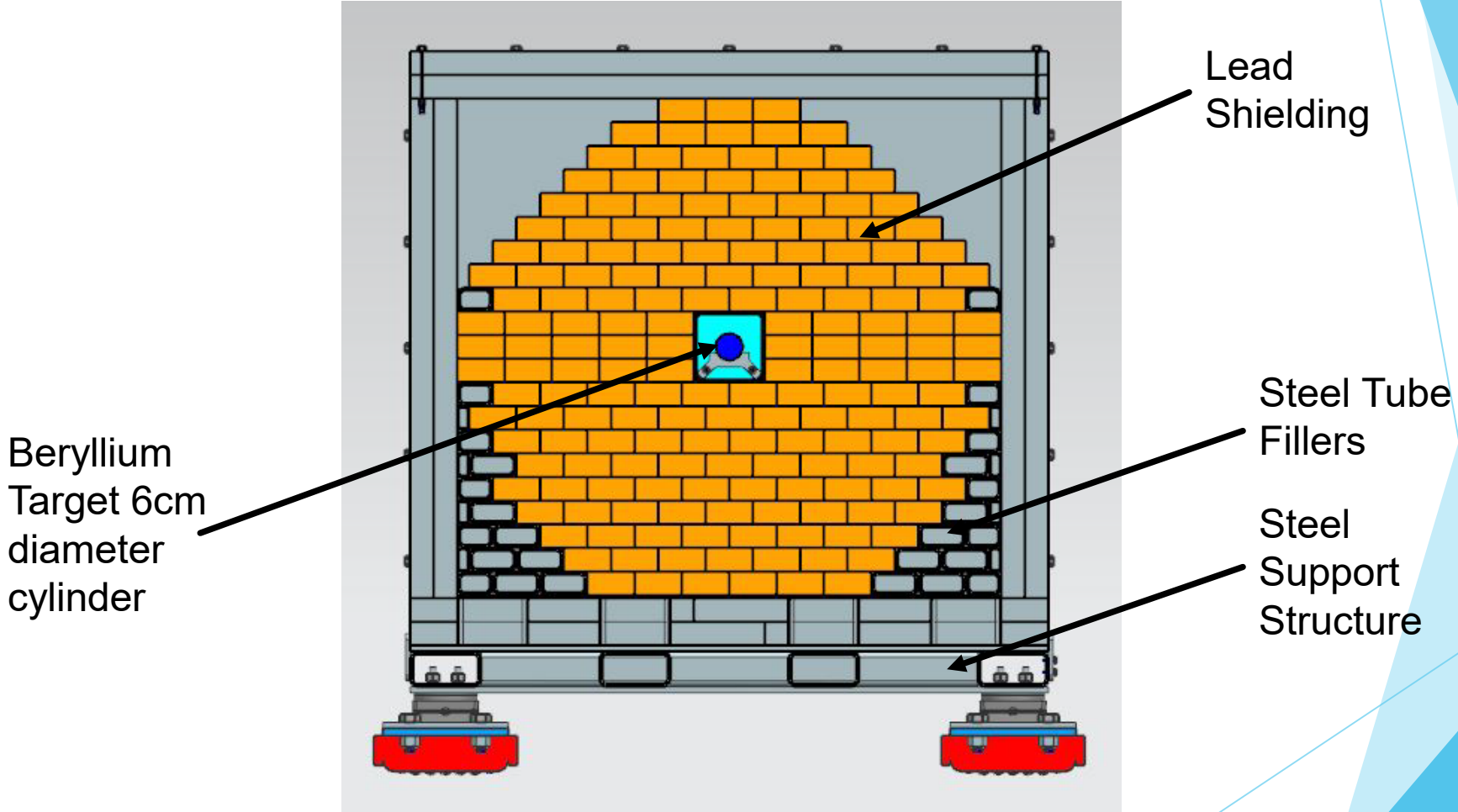

KPT Design Requirements/Specs

- Beryllium Target
 - 6cm diameter
 - 40 cm length
 - 300W power absorption
 - Water cooled- separate chiller system
- Tungsten absorber
 - 15.24 cm square
 - 10cm length
 - 5.2KW power absorption
 - Water cooled - separate Chiller system required

Tungsten Absorber Thermal Analysis

- ▶ Power absorption data provided by Vitaly Baturin
- ▶ Modelled in ANSYS Static Thermal
- ▶ Shows maximum delta T of 117C
- ▶ Outer Surface cooled with water under 100C
- ▶ Maximum Tungsten Temp 216C
- ▶ All can be accommodated

3D Rendering - cooling plates on 4 sides - Max water temp less than 50C - 4 circuits

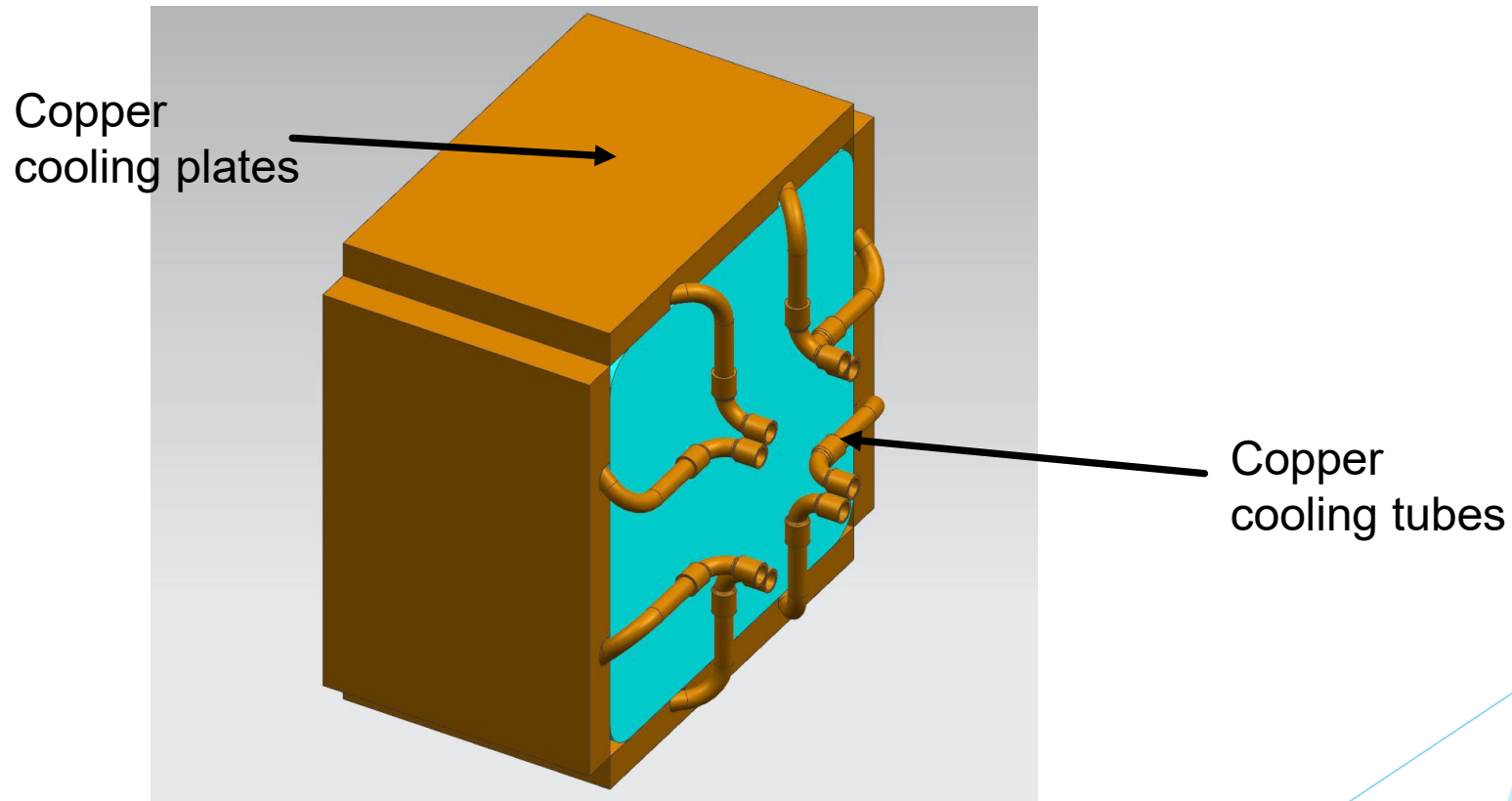

Tungsten Absorber 5.2 KW total input - 2 W/m² convection US face - 80C air temp

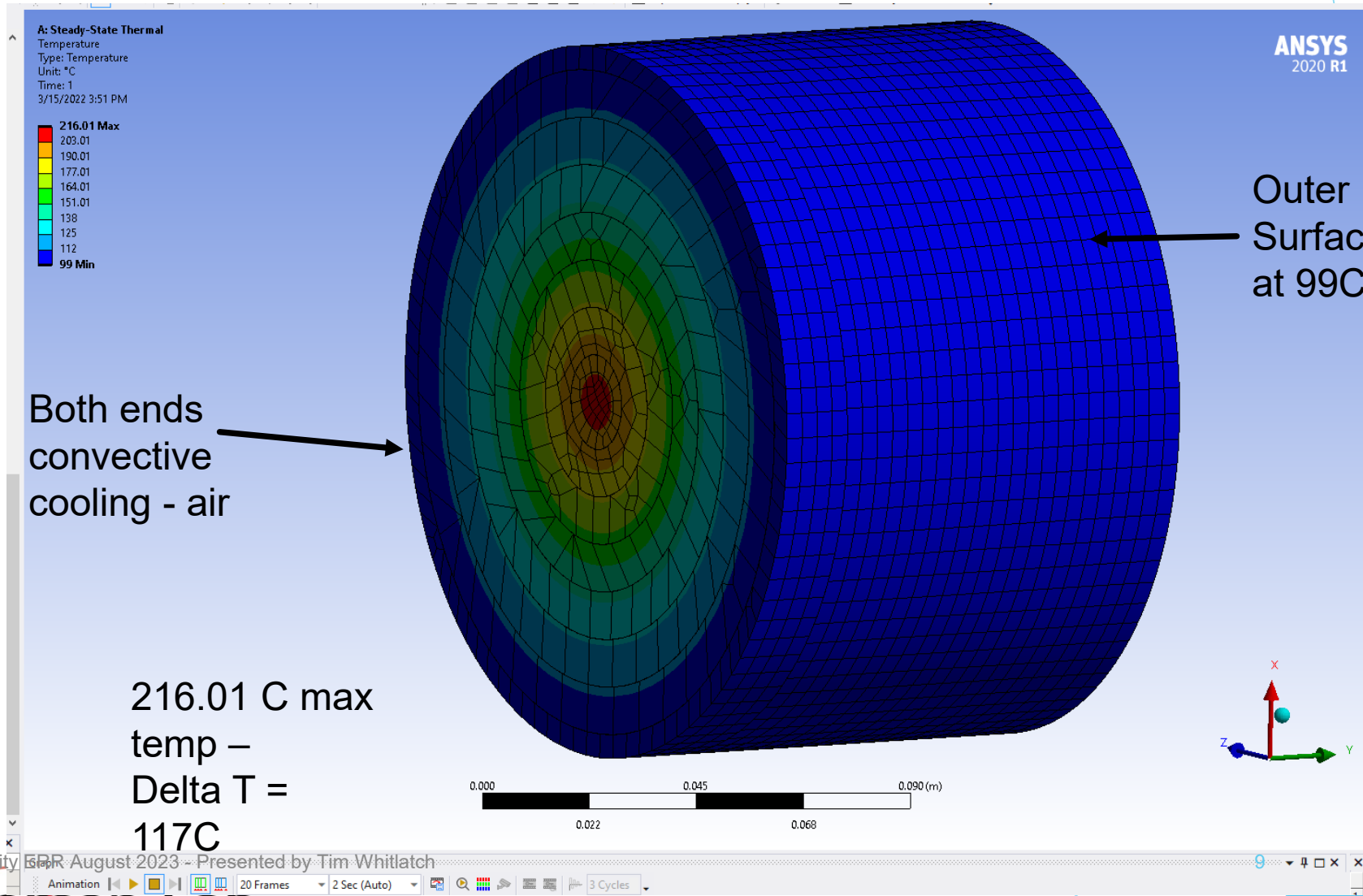

Beryllium Target Water Cooled

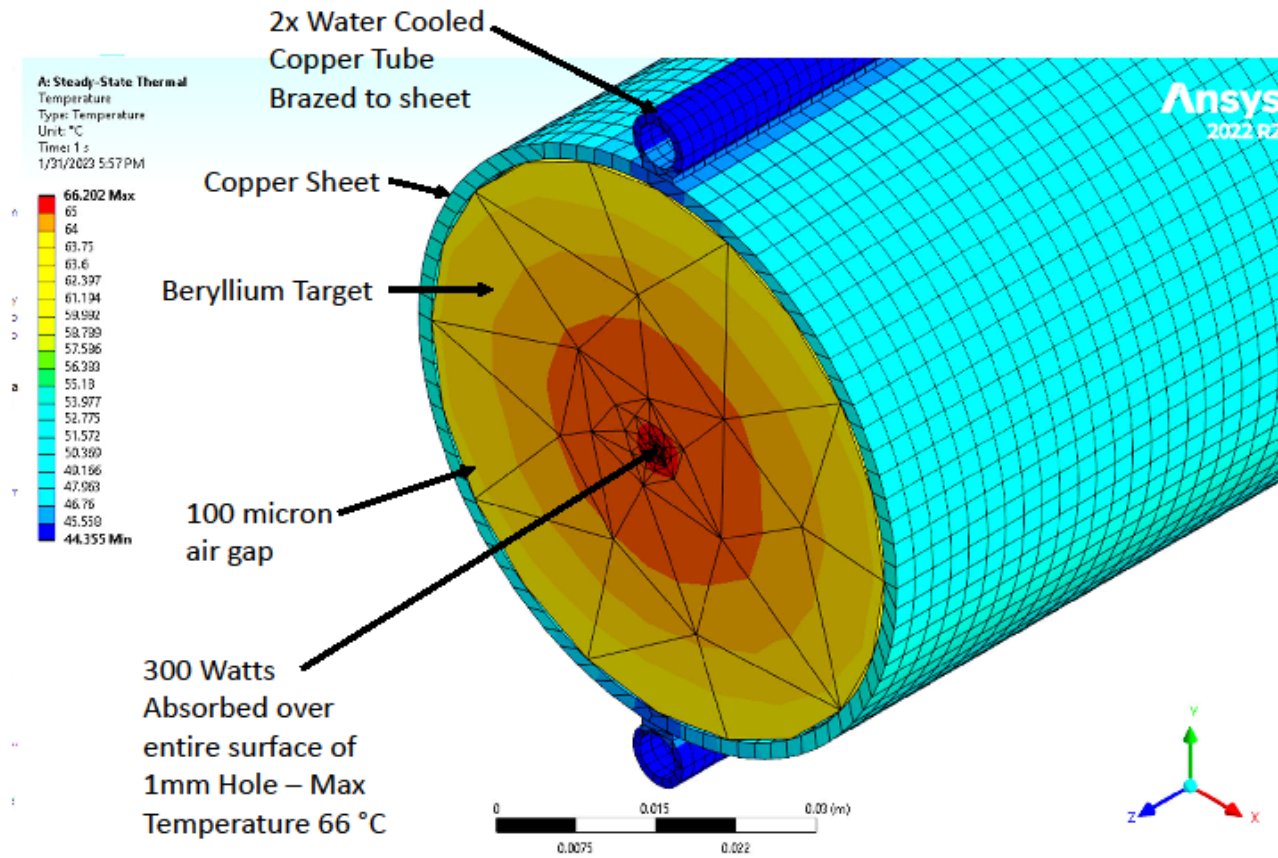

Cooling System For KPT Target and Absorber

- ▶ 5.2 Kw from Tungstem
- ▶ 300 watts from Berylium
- ▶ Separate 6Kw Chiller - recirculated water stays in Hall
- ▶ <3 gpm required
- ▶ Delta T of water less than 10C
- ▶ Tungsten has 4 circuits, beryllium 1 circuit

KPT Design Status

- ▶ 95% Complete Final Design Drawings
- ▶ Need to finalize Collimator or Profiler

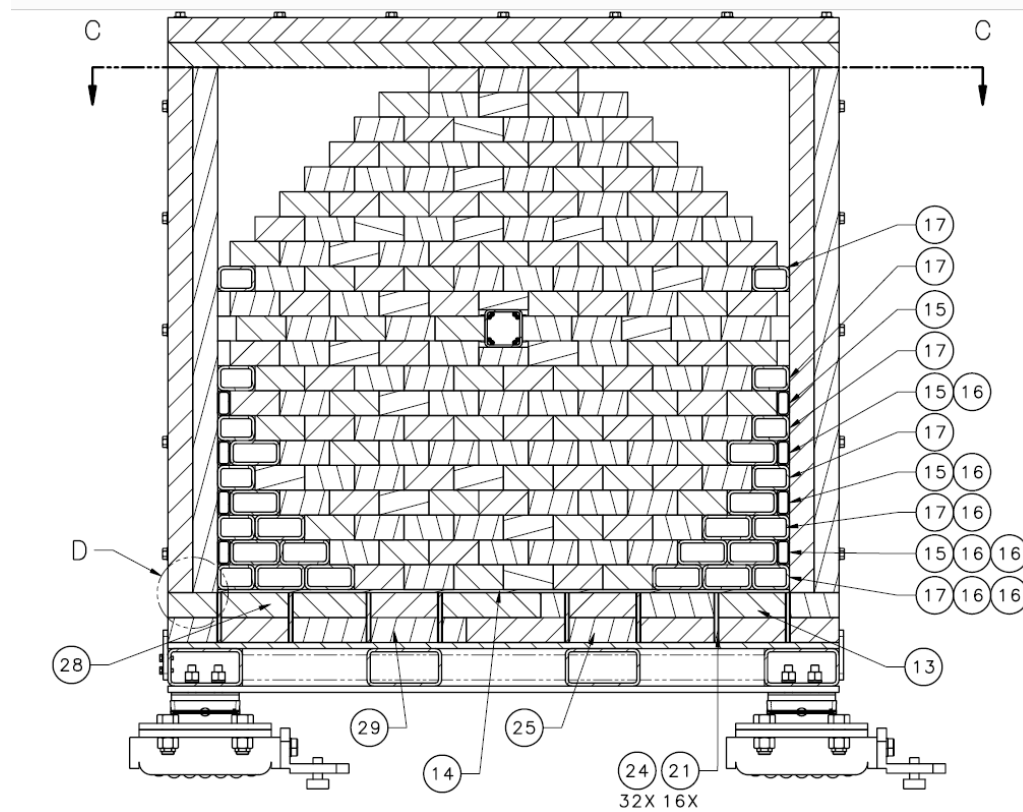

KPT Costs

Equipment	qty	cost ea \$	Fab cost \$	Total cost \$
Beryllium target	1	11,000		11,000
Beryllium support	1	1,100		1,100
Tungsten absorber	1	12,000		12,000
Target Lead Bricks	1190	52	2000	63,880
Target Support structure	1	0	9000	9,000
Hilman rollers	4	850		3,400
Rails	2		1850	1,850
wedge levelers	4	700		2,800
leveler base plate	4		2100	2,100
borated poly sheets	24	800	4800	24,000
Central support tubes	2	800		1,600
Hardware	76	2.5		190
cooling plates	4	1240		4,960
Water cooling system	1	20000		20,000
Shielding wall lead bricks	792	52		41,184
vacuum beamline	1	5000		5,000
Concrete block shielding wall	1188	6		7,128
Water cooling for beryllium	1	1000		1,000
Active collimator stand	1	10000		10,000
PLC	1	2000		2,000
Temperature sensors and PLC co	6	150		900
Support for shield wall	2	3300		6,600
Total cost				231,692

KPT Installation

Task	Days Duration	# Eng	# Tech	FTE Eng	FTE Tech	FTE Facilities	FTE S&A
Remove old Equipment							
Beamline		2	0.1	3	0.0008	0.02	
Profiler		1	0.1	2	0.0004	0.01	
Primary Collimator		1	0.1	2	0.0004	0.01	
Secondary Collimator		2	0.1	3	0.0008	0.02	
Move North Cable Tray		1	0.1	2	0.0004	0.01	
Permanent Magnet		2	0.1	3	0.0008	0.02	
Polarimeter		2	0.1	3	0.0008	0.02	
Stands		2	0.1	2	0.0008	0.02	
Install KPT							
Rails on Floor		3	0.2	2	0.0024	0.02	0.01
Target Support Structure		2	0.3	3	0.0024	0.02	0.01
Bottom layers of target shielding		10	0.2	4	0.008	0.16	
Beryllium Target		1	0.2	2	0.0008	0.01	
Tungsten Absorber		1	0.2	2	0.0008	0.01	0.01
Hook up cooling system and leak check		5	0.1	2	0.002	0.04	
Remaining target shielding		10	0.3	4	0.012	0.16	
New Profiler/Collimator		3	0.2	2	0.0024	0.02	0.01
1st shielding wall		10	0.2	4	0.008	0.16	
2nd shielding wall		10	0.1	4	0.004	0.16	0.01
Permanent magnet		4	0.1	4	0.0016	0.06	0.01
Beamline		5	0.1	3	0.002	0.06	0.01
Test all systems		10	0.2	1	0.008	0.04	
Totals		87			0.0596	1.07	0 0.04
Duration in months		4.35					
Techs required for duration (ave)		2.95					
Eng required for duration (ave)		0.16					
Designer for needed modifications		0.1					
Techs with overhead for safety and training		3.54					

CPS in Tagger Hall

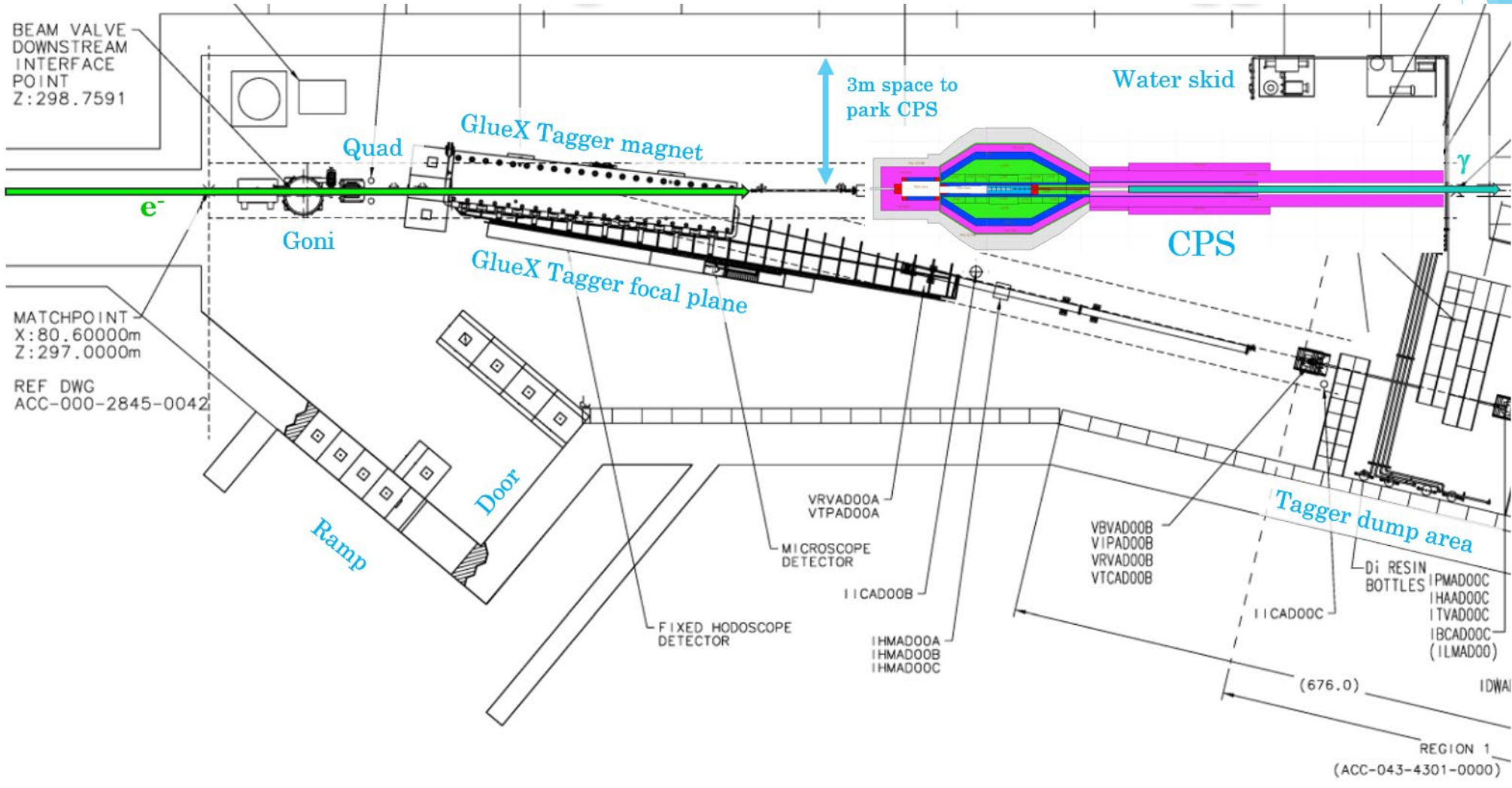

Pavel 75 Keyhole Model 52Kw

C: Steady-State Thermal

Temperature

Type: Temperature

Unit: °C

Time: 1 s

7/24/2023 12:28 PM

Ansys
2022 R2

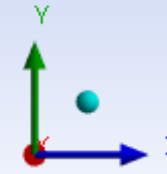
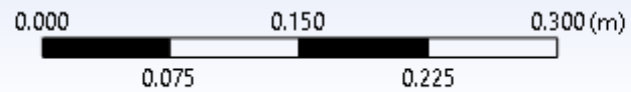
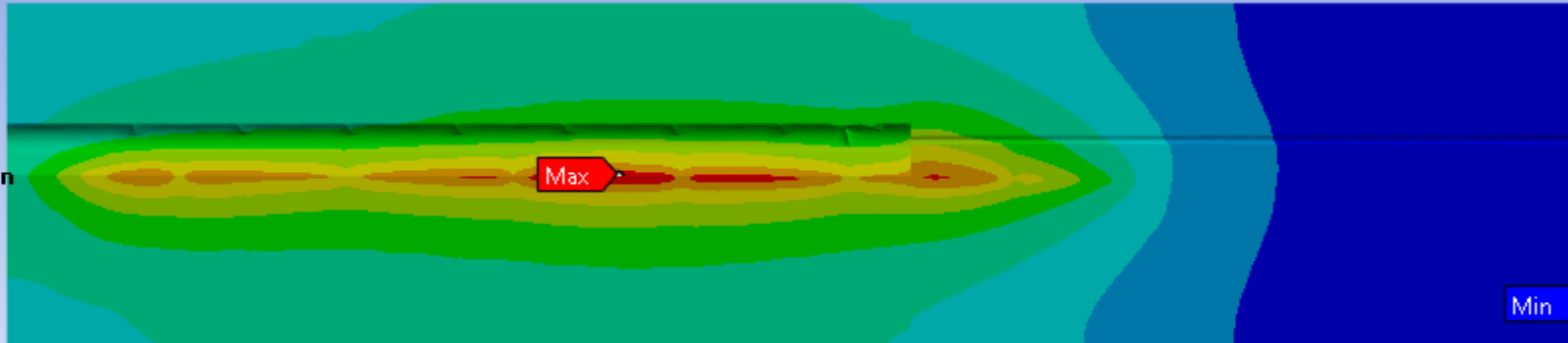
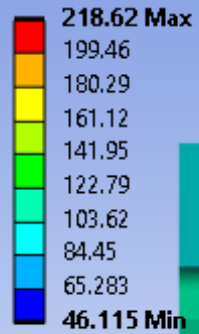

Pavel 75 Keyhole Model 52Kw Thermal Strain

D: Static Structural
Thermal Strain
Type: Thermal Strain(X Axis)
Unit: m/m
Global Coordinate System
Time: 1 s
7/24/2023 12:33 PM

Ansys
2022 R2

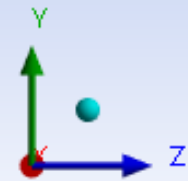
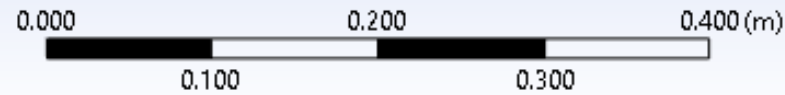
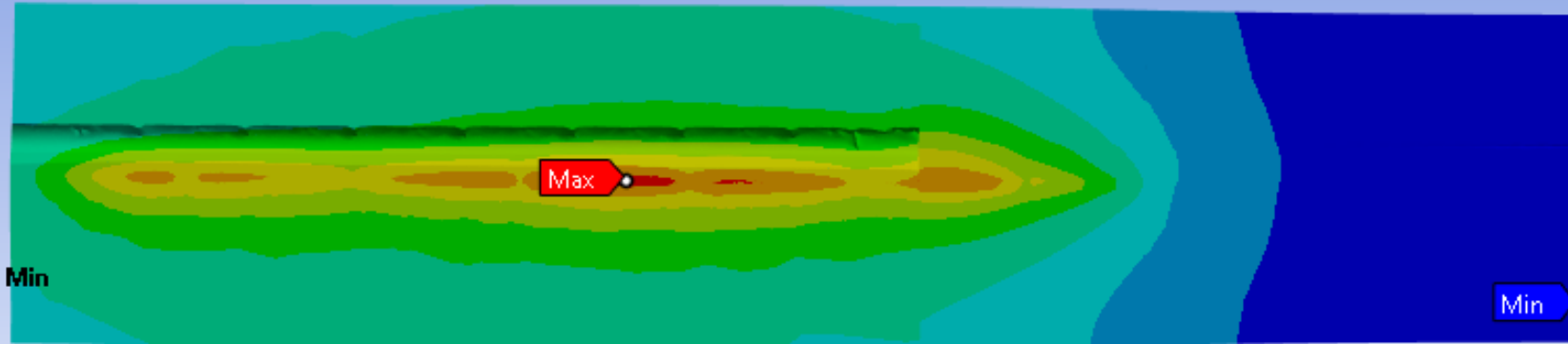
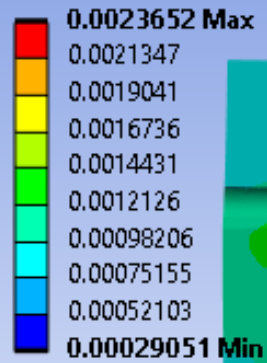

Thermal Stress - copper absorber C101

Full Hard

- ▶ Strain = Alpha * delta T
- ▶ Stress = Youngs Modulus * Strain
- ▶ Strain = $1.674 \times 10^{-5} / \text{C} * 172\text{C} = .0029$
- ▶ Stress = $1.26 \times 10^{11} \text{ Pa} * .0029 = 365 \text{ MPa}$
- ▶ Allowable yield stress = 283 Mpa
- ▶ Model Shows stress higher than yield in linear analysis
- ▶ Need to do non-linear analysis once finalized

Pavel 75 Keyhole Model 52Kw - Total Stress

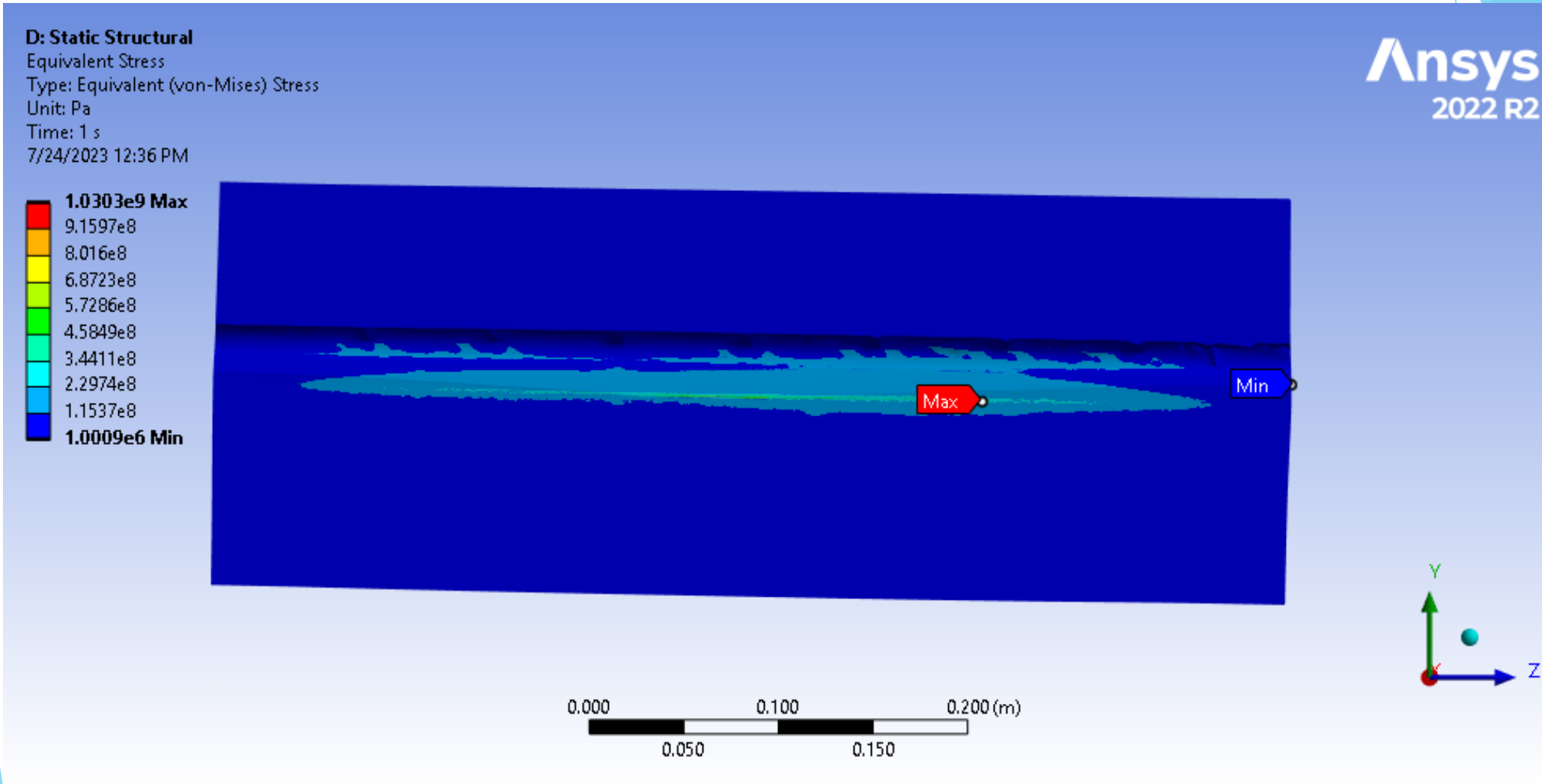

CPS Cooling Requirements

- ▶ 54KW to be removed
- ▶ Use existing Tagger Dump Cooling Skids (60 KW)
 - ▶ 30 gpm total available for 2 skids
 - ▶ Local recirculation LCW
- ▶ 2 circuits needed

Cooling System For CPS

- ▶ 52 Kw from Copper Absorber
- ▶ Use existing dump cooling system - recirculated water stays in Hall
- ▶ 30 gpm required
- ▶ Delta T of water less than 8C
- ▶ 4 water cooling channels
- ▶ Maximum temperature at water cooling channels 98C
- ▶ 2 parallel circuits

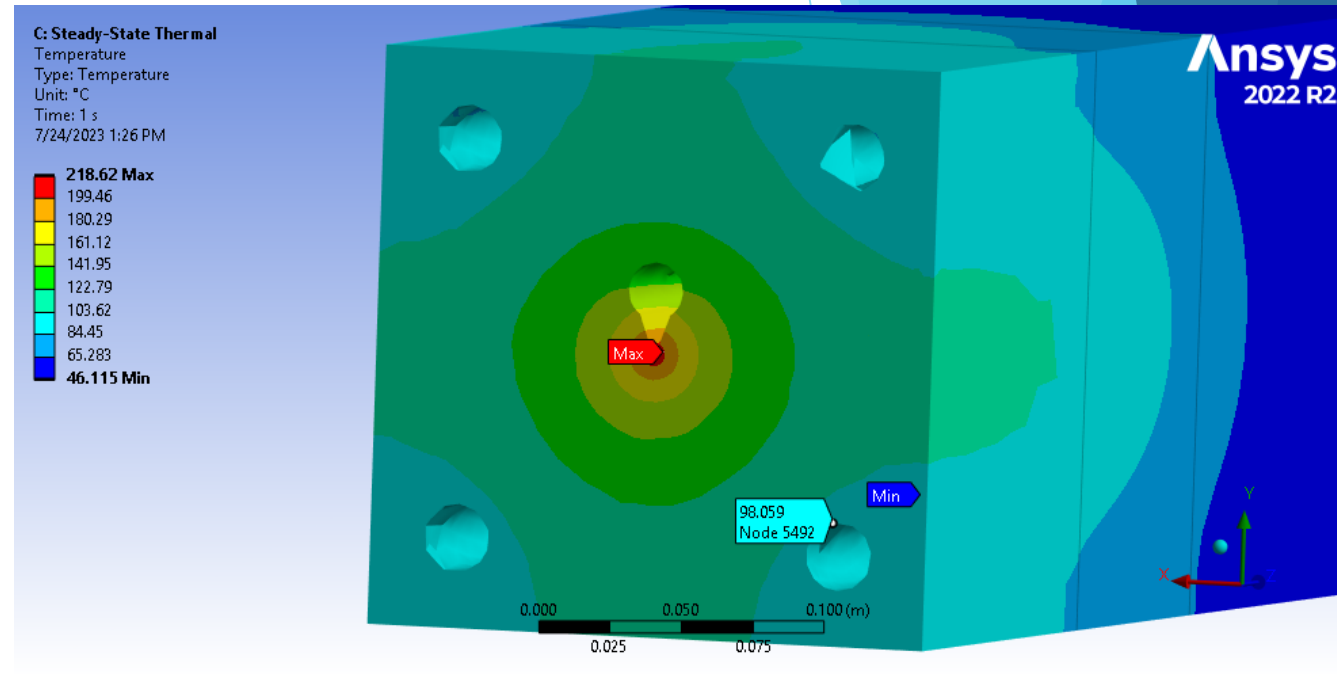

CPS Cost Estimates

Klong Compact Photon Source - Pavel

Component	qty	Lbs	Kg	cost ea \$	Fab cost \$	Total cost \$
Copper absorber	1	1916	869.864	33000	0	33,000
WCu absorbers	138.32	3458	1569.93	1,400		193,648
Lead Bricks	2220.423	57731	26209.9	52	2000	117,462
borated poly sheets	89.48125	14317	6499.92	800	35792.5	107,378
Iron core	1	3370	1529.98	16850	0	16,850
Iron shield	1	27555	12510	137775	0	137,775
Barite concrete (CPS and beamline)	893.926	55132	25029.9	10	10,000	18,939
Adjustment components	3			2800		8,400
Support Structure	1			30000		30,000
Rail System	1			4000		4,000
Water Cooling System	1			5000		5,000
Beamline Plus girder	1			10000		10,000
Radiator (3 position remotely)	1			15000		15,000
Magnet	1	2202.65	1000	110000		110,000
Power Supply	1			100000		100,000
Machining of shielding components	1			15000		15,000
Concrete pier	1			20000		20,000
Temperature sensors and wires	20			200		4,000
Vacuum Pump and controllers	1			20000		20,000
PLC modules and shielding	5			1500		7,500
Total Materials		165681.65	75219.5			973,952

Hall D K-Long Facility ERR August 2023 - Presented by Tim Whitlatch

CPS Required Design Manpower

KLONG CPS Design						
	Days	#	#	FTE	FTE	FTE
Task	Duration	Eng	Des	Eng	Des	Facilities
Design new beamline						
Beamline layout	10	0.1	1	0	0.04	
Perm Magnet setup	2	0.1	1	0	0.01	
Vacuum pump setup	2	0.1	1	0	0.01	
Final Beamline drawings	25	0.2	1	0.02	0.1	
Component procurement	200	0.05	0.05	0.04	0.04	
Design CPS						
Design Concrete Base	30	0.2	1	0.02	0.12	0.12
Design rails	15	0.3	1	0.02	0.06	
Design support structure/strongback	25	0.4	1	0.04	0.1	
Design adjustment system	25	0.1	1	0.01	0.1	
Design magnets	65	0.4	1	0.1	0.26	
Procure Magnets and Power Supplies	250	0.1	0.1	0.1	0.1	
Design radiator	25	0.1	1	0.01	0.1	
Design shielding	120	0.2	1	0.1	0.48	
Test Magnets	5	0.2	2	0	0.04	
Design alignment system	45	0.2	1	0.04	0.18	
Design cooling system	30	0.4	1	0.05	0.12	
Procure all shileding components	200	0.1	0.05	0.08	0.04	
Procure rails, strongback and cooling	200	0.1	0.05	0.08	0.04	
Procure radiator components	80	0.1	0.05	0.03	0.02	
Installation Drawings	40	0.1	1	0.02	0.16	
Totals	424	Days		0.76	2.11	0.12
Duration in months	21.2					
Des required for duration (ave)	1.20					
Eng required for duration (ave)	0.43					

CPS Installation

KLONG CPS Installation							
Task	Days Duration	# Eng	# Tech	FTE Eng	FTE Tech	FTE Facilities	FTE S&A
Remove old equipment							
Crates		5	0.1	3	0.002	0.06	
microscope		3	0.1	3	0.0012	0.04	
Hodoscope		3	0.1	2	0.0012	0.02	
Beamline		5	0.2	3	0.004	0.06	
Install CPS							
Install Concrete Base		10	0.1	1	0.004	0.04	0.12
Install rails		4	0.3	3	0.0048	0.05	0.01
Install support structure		10	0.3	3	0.012	0.12	0.02
Install magnets		10	0.2	3	0.008	0.12	
Install Power Supplies		5	0.1	3	0.002	0.06	
Survey and alignment		2	0.2	1	0.0016	0.01	0.01
Install radiator		2	0.3	2	0.0024	0.02	0.01
Install partial shielding		20	0.2	4	0.016	0.32	
Test Magnets		5	0.2	2	0.004	0.04	
Survey and Alignment		2	0.2	1	0.0016	0.01	0.01
Install remaining shielding		20	0.2	4	0.016	0.32	
Install cooling system		10	0.4	3	0.016	0.12	
Install Perm Magnet		4	0.2	3	0.0032	0.05	0.01
Install beamline & windows		5	0.2	3	0.004	0.06	
Install New Girder		3	0.1	3	0.0012	0.04	0.01
Setup and test controls		20	0.1	1	0.008	0.08	
Final Survey		2	0.1	1	0.0008	0.01	0.01
Totals		150			0.114	1.63	0.12
Duration in months		7.5					
Techs required for duration (ave)		2.61					
Eng required for duration (ave)		0.18					
Techs with overhead for safety and training		3.13					

Plus Hall Work
Coordinator

Civil requirements

- ▶ Collimator Floor Capable of supporting additional 120+ Tons
- ▶ Tagger Hall Floor Capable of supporting additional 120+ Tons
 - ▶ Facilities will re-evaluate when final weight is determined
 - ▶ Facilities to install concrete pier

Conceptual Flux Monitor Setup in Hall D

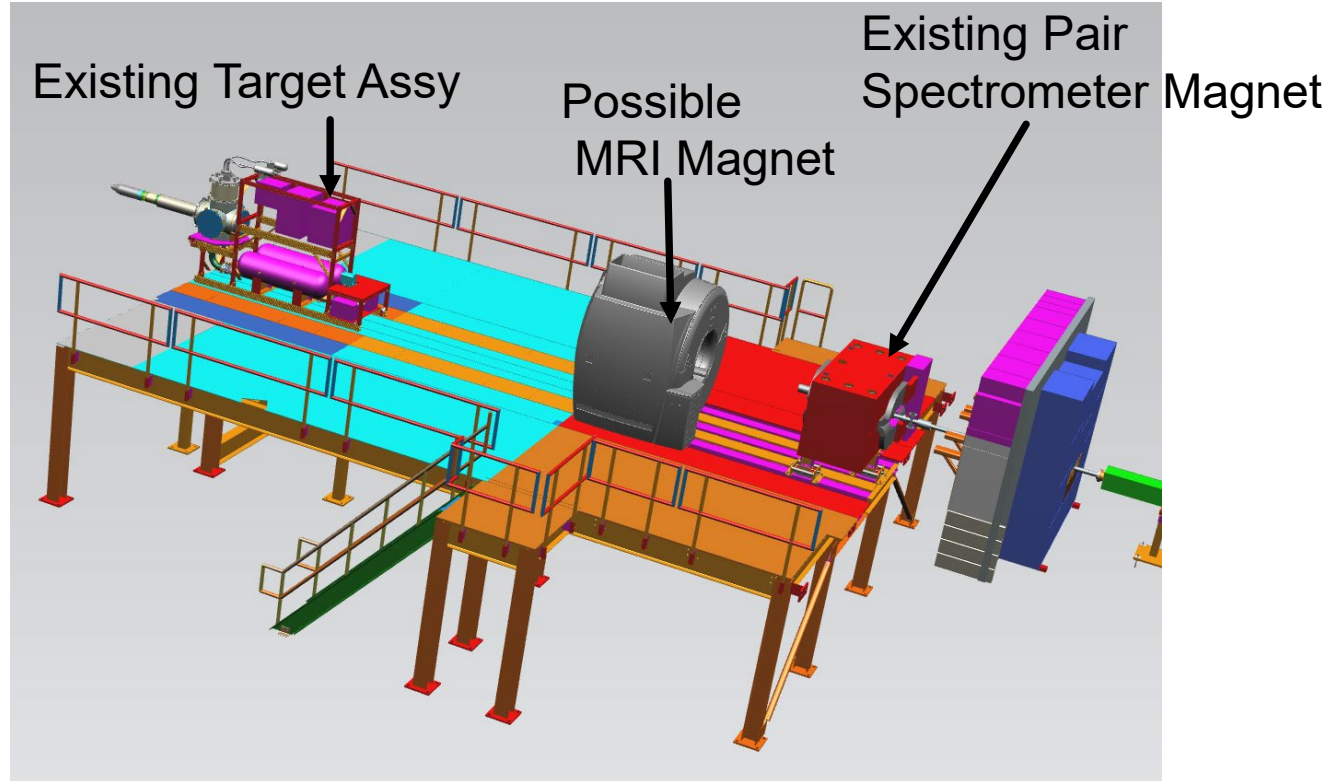

Proposed MRI Magnet can fit in existing space and platform can support the weight

Decommissioning

- ▶ CPS
 - ▶ Roll CPS to South wall in the Tagger Vault
 - ▶ Remove CPS beamline and shielding
 - ▶ Reinstall GlueX beamline
 - ▶ Reinstall Hodoscope, Microscope and electronics
 - ▶ Reinstall Dump cooling
 - ▶ 6 months duration
- ▶ KPT
 - ▶ Roll Target to North wall
 - ▶ Remove KPT shielding and beamline
 - ▶ Reinstall GlueX beamline
 - ▶ 4 months duration
- ▶ KFM
 - ▶ Remove KFM setup
 - ▶ Reinstall GlueX beamline, detectors and target
 - ▶ 1-3 months duration

Status

- ▶ Collimator Cave Final Drawings 95% Complete - can be found here O:\halld_engineering\KLONG\COLLIMATOR CAVE\DRAWINGS EXPORT 5-22-23
- ▶ Preliminary Thermal Analysis Complete for CPS
- ▶ Final Stress analysis for CPS required
- ▶ Integrated Installation Plan Needed
- ▶ Flux Monitor in Conceptual Phase - Proposed MRI will fit
- ▶ CPS Design Work to start Following ERR Approval
- ▶ Hall D hiring an additional Engineer

Backup

Cave Layout Elevation

