



# Conceptual Design of Compact Photon Source for KLF

Hovanes Egiyan

Pavel Degtiarenko

# Overview

- Requirements for CPS
- Model Description
- Photon Beam from CPS
- Radiation Environment
- Temperature in CPS absorber
- Electron Beam Requirements for CPS
- Summary



8/2/2023

KLFF ERR-1 Review

Hovanes Egiyan

2

# Introduction



8/2/2023

KLIF ERR-1 Review

Hovanes Egiyan

# KLF Layout

- KLF experiment needs to produce high intensity photon beam for KPT.
- CPS stands for Compact Photon Source; it has been proposed as the photon source.
- The only possible location for such a source is the Tagger Hall.
- CPS beamline will require major modifications to GlueX photon beamline.

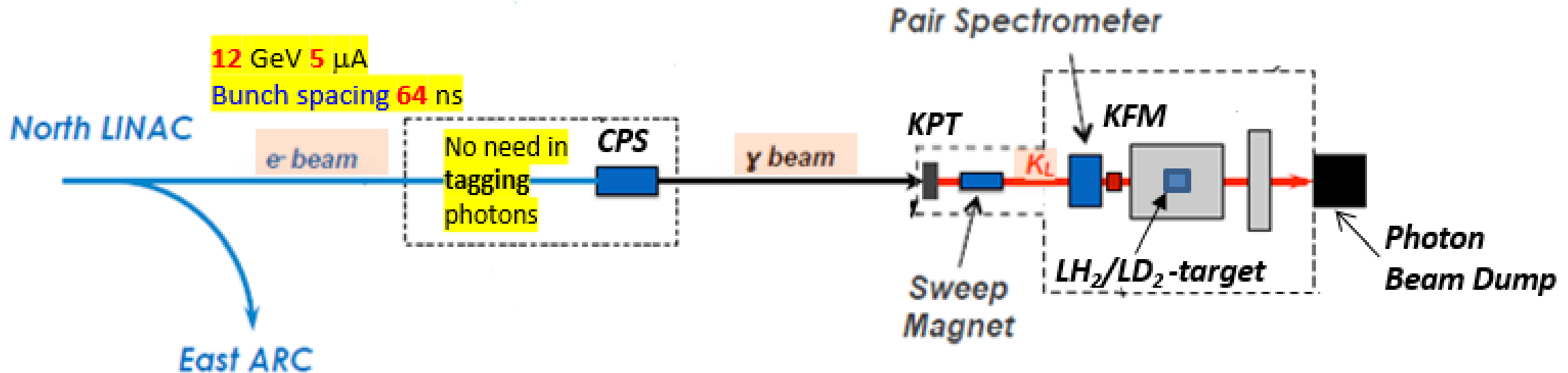

# Review Charge Items

- Is there any R&D needed to be done prior to start the construction of the Klong Facility? ✓
- What is the status of the Compact Photon Source (CPS)? Specifically:
  - a) the conceptual design ✓
  - b) the evaluation of the produced radiation. In particular, the following points should be discussed:
    - 1. the approximations made in the Monte Carlo simulations and which code has been used; ✓
    - 2. the energy deposition and the absorber temperature; ✓
    - 3. the prompt dose and activation around the CPS and the Tagger Hall; ✓
    - 4. the magnet performance and its coils lifetime; ✓
    - 5. ~~the water cooling system and possible contaminations.~~ (Tim's talk)
- Will civil constructions be needed to contain the radiation in the Tagger Hall? Not needed
- What will the photon beam quality be? ✓
- What are the requirements of the electron beam on the CPS? ✓
- What is the decommissioning plans for the K-Long Facility (CPS, KPT,...) and the activated components? A brief outline is sufficient. ✓



# CPS Requirements

- Intense photon flux of  $\Phi_\gamma > 10^{12}$  photons per second with  $1.5 \text{ GeV} < E_\gamma < 12 \text{ GeV}$ .
- Photon beam spot size at KPT with  $2 \cdot \text{FWHM} < 6\text{cm}$  to make full use of KPT size.
- Radiation environment in the Tagger Hall similar or better than what GlueX would get with  $5\mu\text{A}$  electron beam on nominal GlueX diamond radiator.
  - ❑ Prompt dose rate equivalent of  $\sim 20 \text{ rem/h}$ .
  - ❑ Activation dose rate  $< 5 \text{ mrem/h}$  after 10000 hours of operations and 1 hour of cool-down time.
  - ❑ RadCon limits  $< 1 \text{ mrem/h}$  outside of the Tagger Hall.
- Cooling system design that is sufficient to handle  $\sim 54 \text{ kW}$  power delivered to CPS.
  - ❑ It will need to be closed-circuit system to avoid activation/contamination.
- GlueX beamline should be restored relatively quickly without disassembly of CPS.
  - ❑ GlueX photon beamline is wider than CPS beam channel and is under vacuum.
  - ❑ We decided to build a movable platform to move CPS beam-left.
  - ❑ There is sufficient space in the tagger hall for the current CPS design.



# Software

- FLUKA 2021.2.9
  - ❑ CPS design
  - ❑ Prompt radiation levels
  - ❑ Activation levels
  - ❑ Accumulated doses
  - ❑ Power deposition in the materials
  
- OPERA 18R2
  - ❑ Magnet prototyping
  - ❑ Magnetic field calculations
  
- ANSYS Workbench 2022 R2
  - ❑ Thermal analysis
  - ❑ Stress and deformation analysis
  
- Wolfram Mathematica 13.1.0
  - ❑ Thermal analysis



# CPS Positioning in the Hall D Tagger

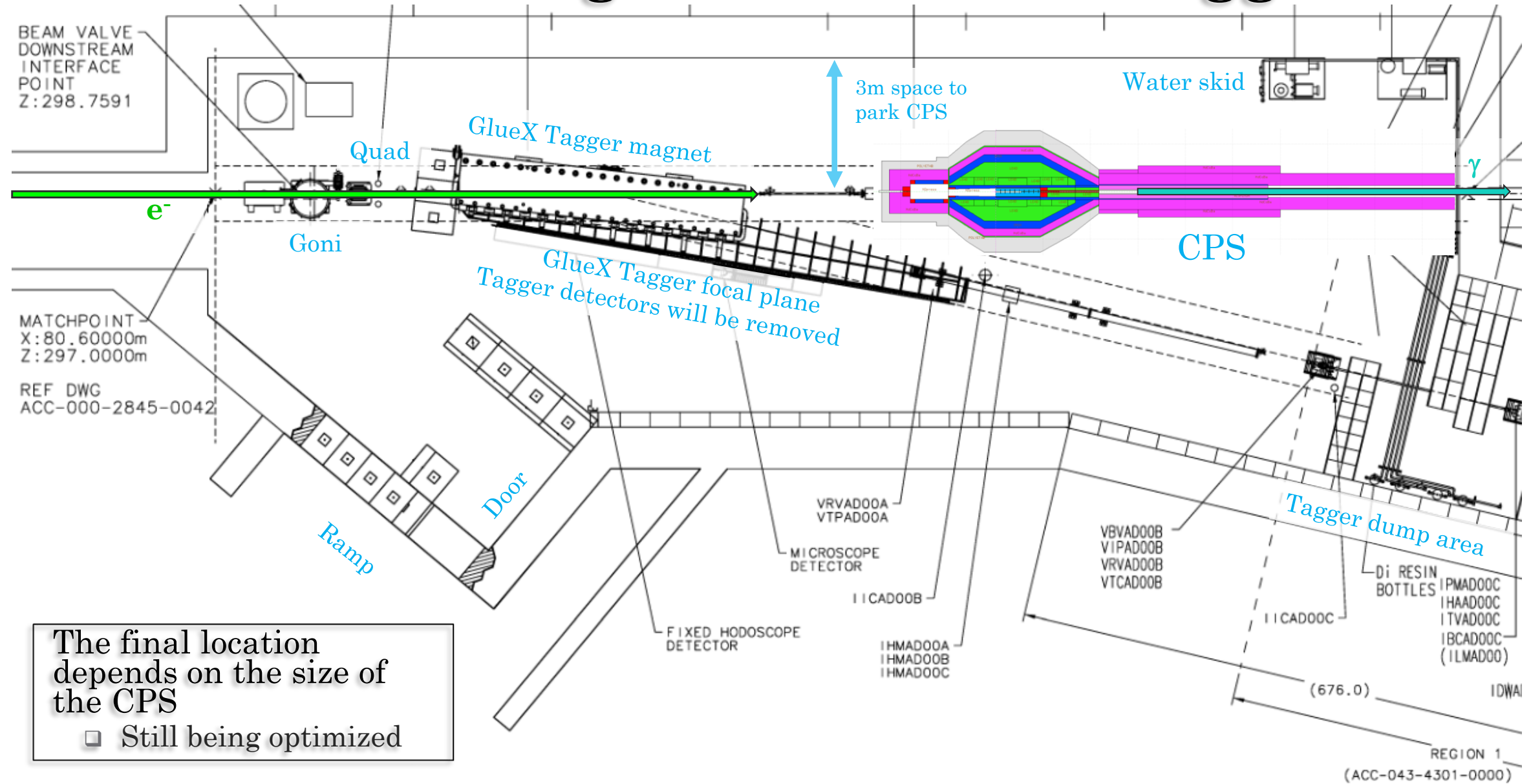

The final location depends on the size of the CPS

- Still being optimized



# CPS Model

---

# Development of the Design

- We started with Hall C version of the CPS.
  - ❑ Very compact design
    - Small footprint in the hall.
    - The radiator, magnet, and the absorber are in the same region.
    - High power deposition densities leading to high temperatures in the core.
    - Requires a magnet with high magnetic field  $B > 3$  Tesla.
  - ❑ Hall C design costs \$2M or more mainly due to the use of tungsten as shielding material.
- Considered two different models with lower magnet field during last year.
  - ❑ Vitaly Baturin developed a model in the summer of 2022.
  - ❑ Pavel Degtiarenko proposed another model in the fall of 2022.
  - ❑ After studying both models, we chose one for further optimization and engineering design.
- Currently we are in process of optimizing the conceptual design.
- People involved in CPS design work:
  - ❑ Physicists: V. Baturin, P. Degtiarenko, H. Egiyan
  - ❑ Engineers: T. Whitlatch
  - ❑ We may recruit a mechanical engineer to work on engineering design in the fall.





# Hall D CPS Model

- Magnet and the absorber are separated by 1 meter .
  - ❑ No heat load on the magnet poles and coils from the core.
  - ❑ Low radiation exposure to the magnet.
- Clean-up magnet downstream for charged particles.
  - ❑ Utilize the existing permanent magnet used in GlueX beamline.
- No tungsten is used in the CPS shielding.
  - ❑ We save cost by using lead instead.
  - ❑ Small amount of a tungsten-copper mix is used for shielding the beam channel and magnet coils.

- Total estimated weight of CPS is approximately 76 metric tons.
  - ❑ Includes downstream beamline shielding.
  - ❑ Movable platform will add more weight.
  - ❑ Tagger Hall should easily handle CPS weighing 100 tons.
- Estimated cost of the current design is ~\$1M for CPS
  - ❑ Upstream beamline instrumentation will be extra.
- Tim Whitlatch will discuss engineering and cost related aspects in detail.

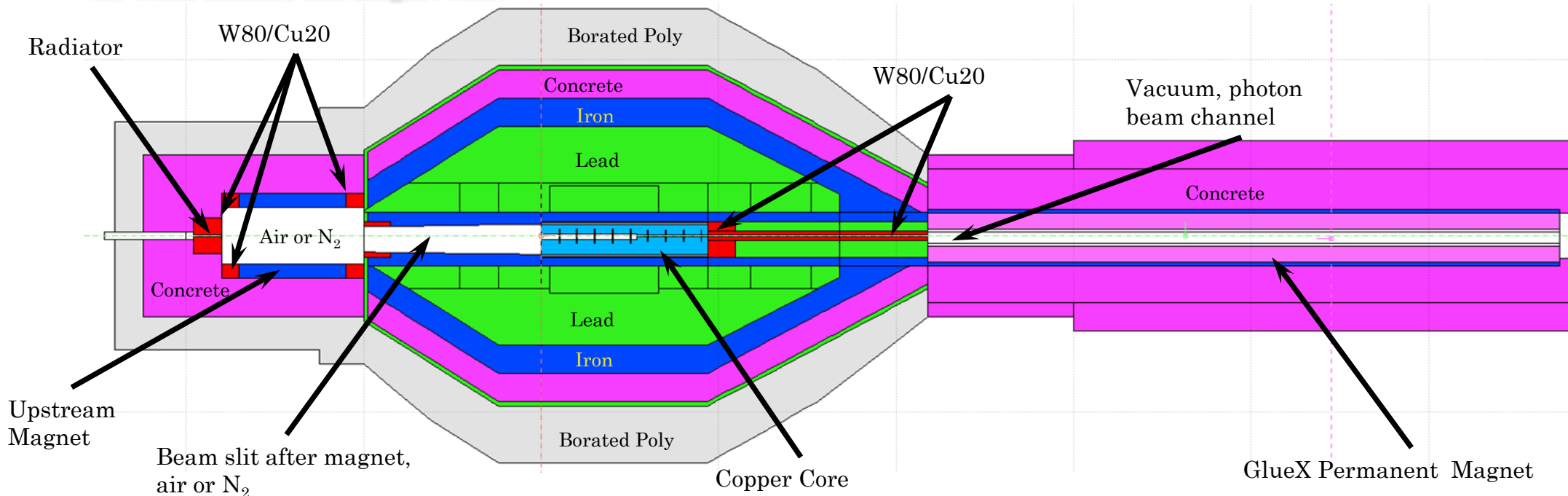

# CPS Absorber

- Copper core with dimensions of 20cm x 20cm x 94cm.
  - ❑ To absorb and dissipate the power.
  - ❑ Copper is not ferromagnetic and is a very good heat conductor.
- Varying size beam channel to trap the secondary particles from the electromagnetic shower.
  - ❑ Wider cavity upstream for trapping electrons and EM shower remnants.
  - ❑ Narrow conical channel with diameter ~1cm for outgoing photons.
- Cooling channels for water flow capable of evacuating ~54 kW power.
- Copper absorber is surrounded by air, steel, and W/Cu mix.
  - ❑ No contact with lead.

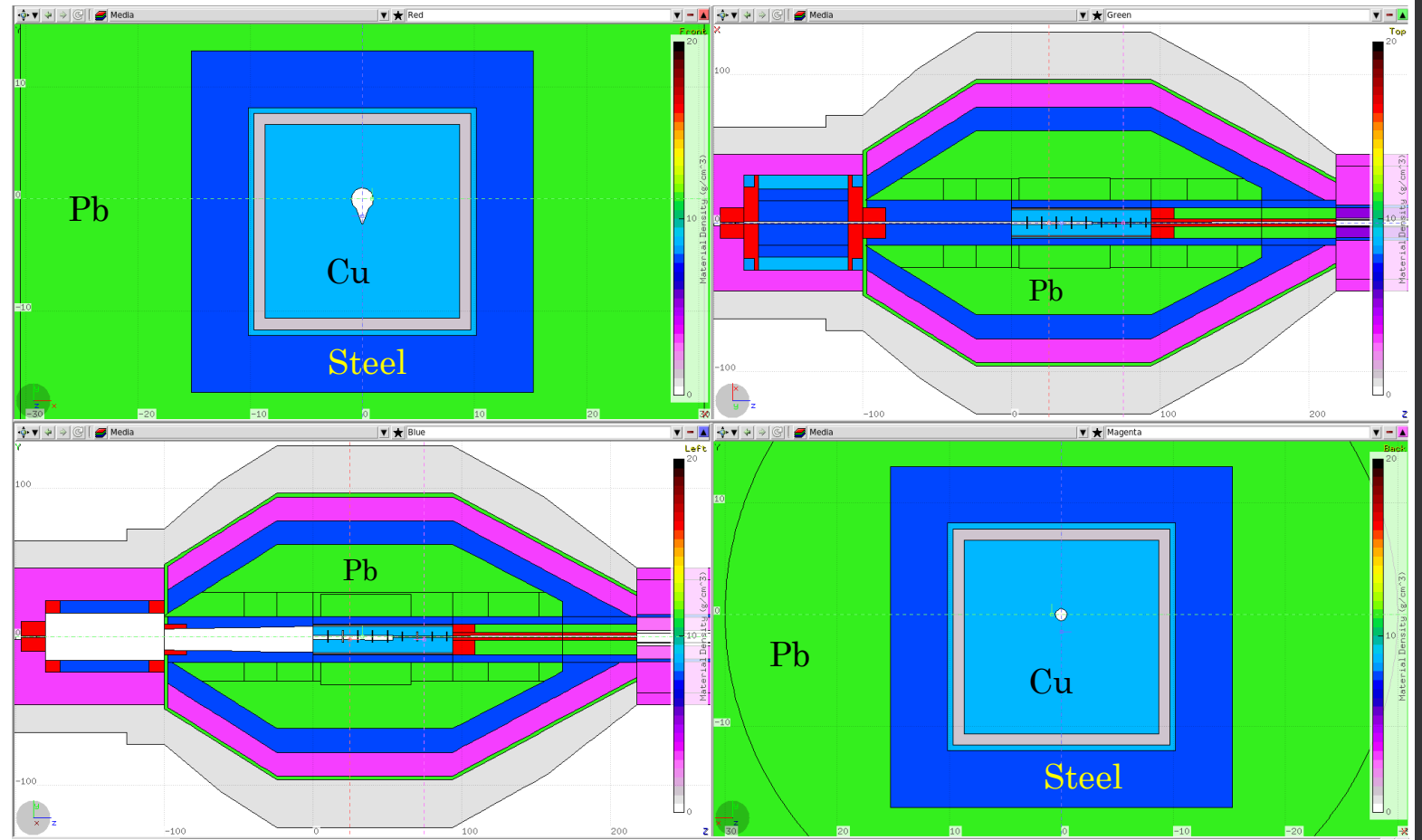
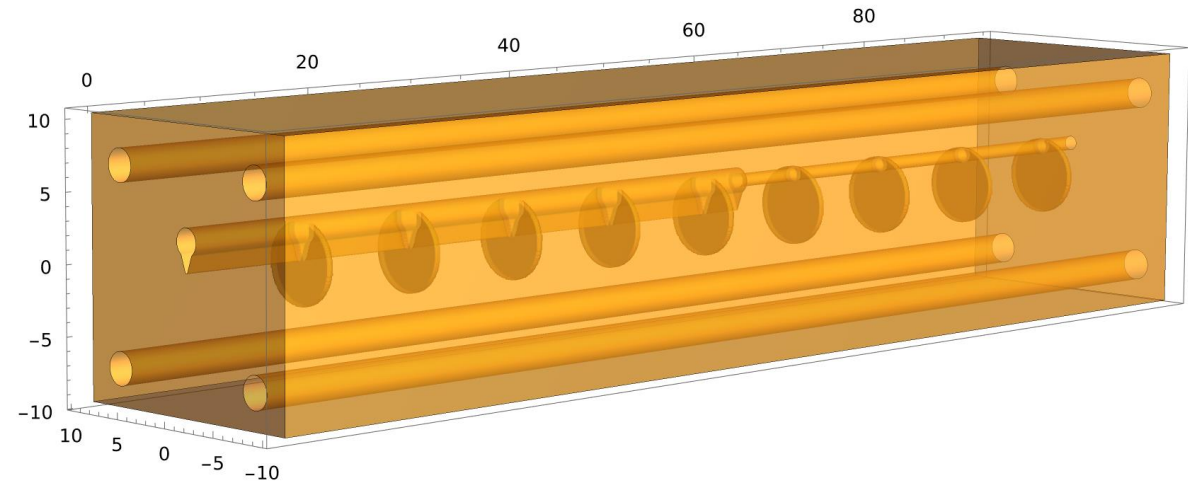



# Upstream Magnet

- Current CPS design requires  $\sim 0.48$  T-m magnetic field in the x-direction.
- We developed a draft model of the magnet.
  - ❑ Magnet has 60 cm long coils.
  - ❑ Bedstead shape of coils for less radiation exposure.
  - ❑ The closest distance from coils to the beam center is  $\sim 11$ cm.
- The gap should be on the order 1 cm or more to avoid interaction with beam tails and halo.
  - ❑ Current design assumes 1.4 cm gap.
- Iron yoke with 8 cm thickness.
  - ❑ Total length of the yoke is 60cm
  - ❑ The transverse size of the yoke is 46cm x 48 cm.
- Chamfered iron poles.
- We used OPERA to calculate the field in the model.
  - ❑ The model can provide a dipole field of 0.67 T at 67 A/cm<sup>2</sup> current density in the coils.
    - Should be able to use Tagger Magnet power supply.
  - ❑ The field in the yoke is far from saturation point.
  - ❑ Field map is used in FLUKA simulations, scaled by a factor x1.15 .

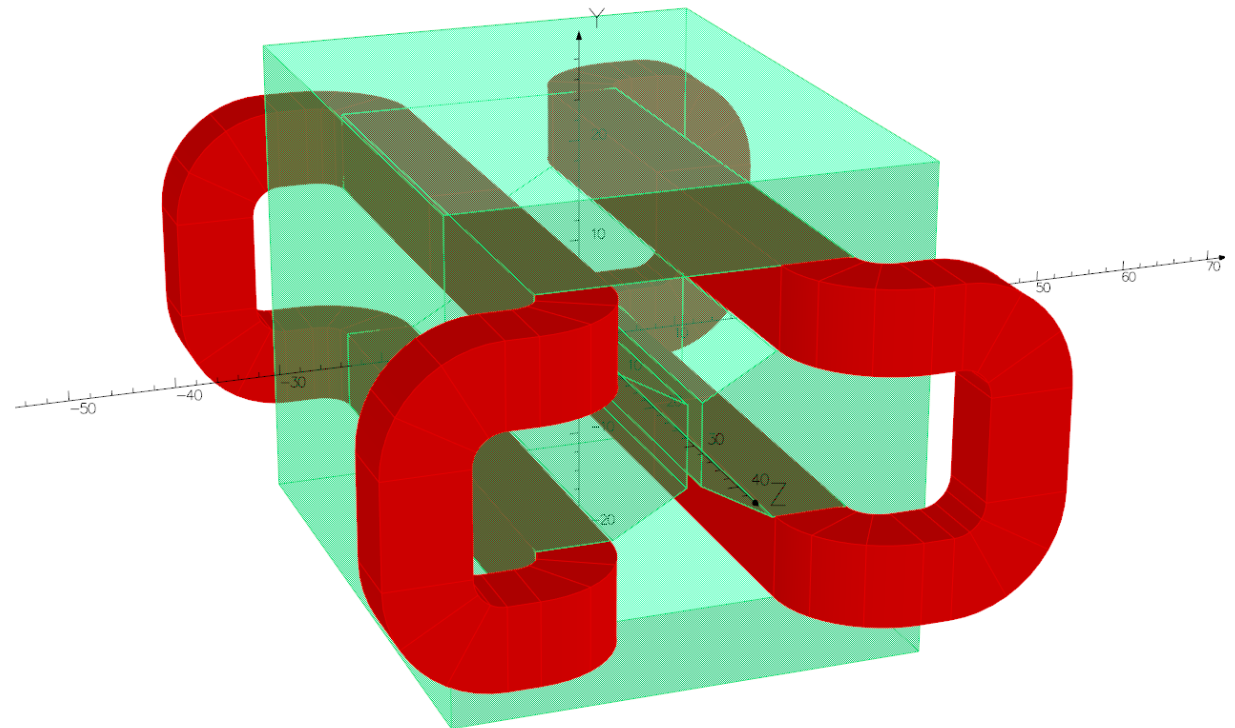
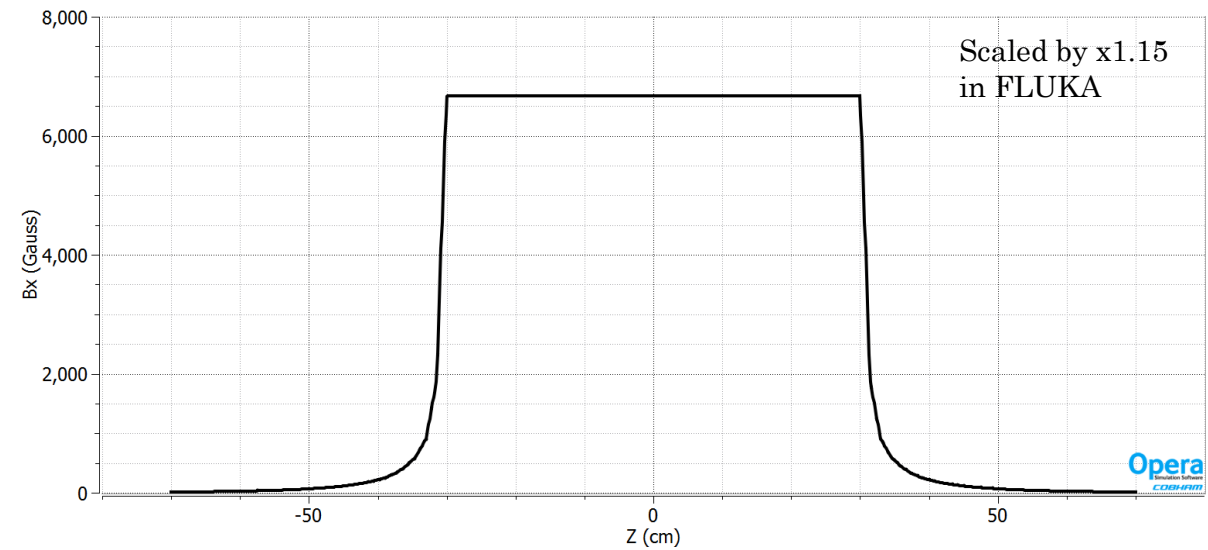

# Downstream Magnet

- GlueX uses a 140" long permanent magnet from FNAL beamline to prevent electrons from leaking into the main hall.
  - ❑ Electron beam is interlocked to tagger magnet current at the power supply.
  - ❑ Leaks are only possible for short bursts when the tagger magnet trips.
  - ❑ KLF still needs it to prevent electron from accidentally penetrating to the hall.
- The magnetic material is made of strontium ferrite.
  - ❑ Can handle over  $10^7$  Gy radiation dose, according to the specs.
- Provides  $\int B \cdot dL = 0.822$  T·m field integral.
  - ❑ The exact field of this magnet is not important for CPS itself.
    - We use it to remove the charged particles from the photon beamline.

Cross section of the FNAL PDV magnet used by GlueX in the tagger hall.

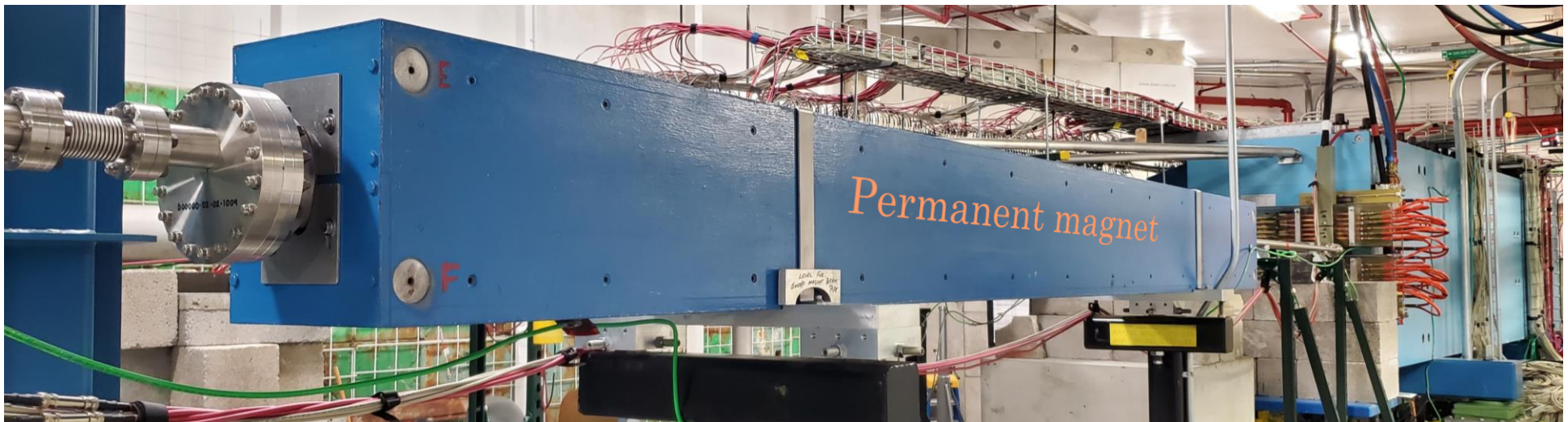
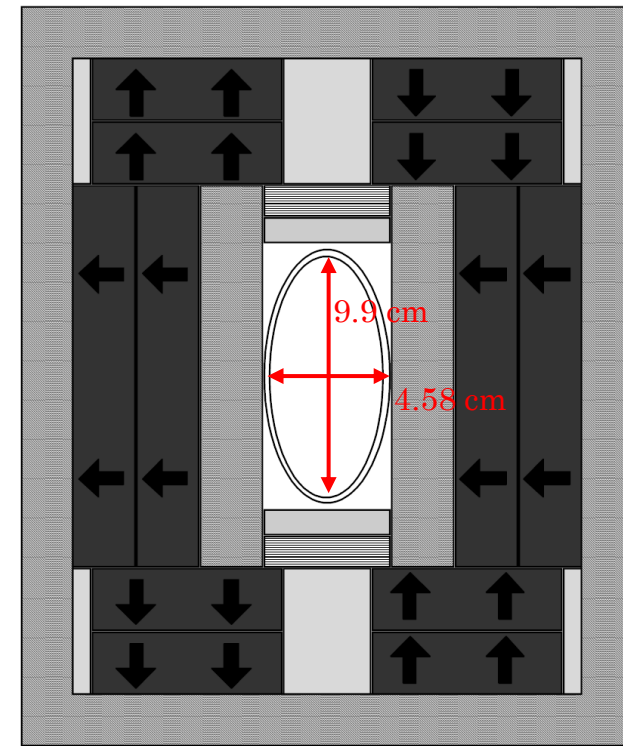

# Photon Beam

- We used FLUKA to estimate the beam profile at KPT.
- Clean photon beam profile with  $\sigma_\gamma \approx 1.5$  cm width.
  - ❑ The width is dominated by multiple scattering in the 10% radiator.
  - ❑ Vertical distribution has a slight asymmetry (on 0.1% level) favoring negative y-s.
- Charged particle and neutron rates from CPS measured at the KPT location is expected to be very small compared to the photon flux.

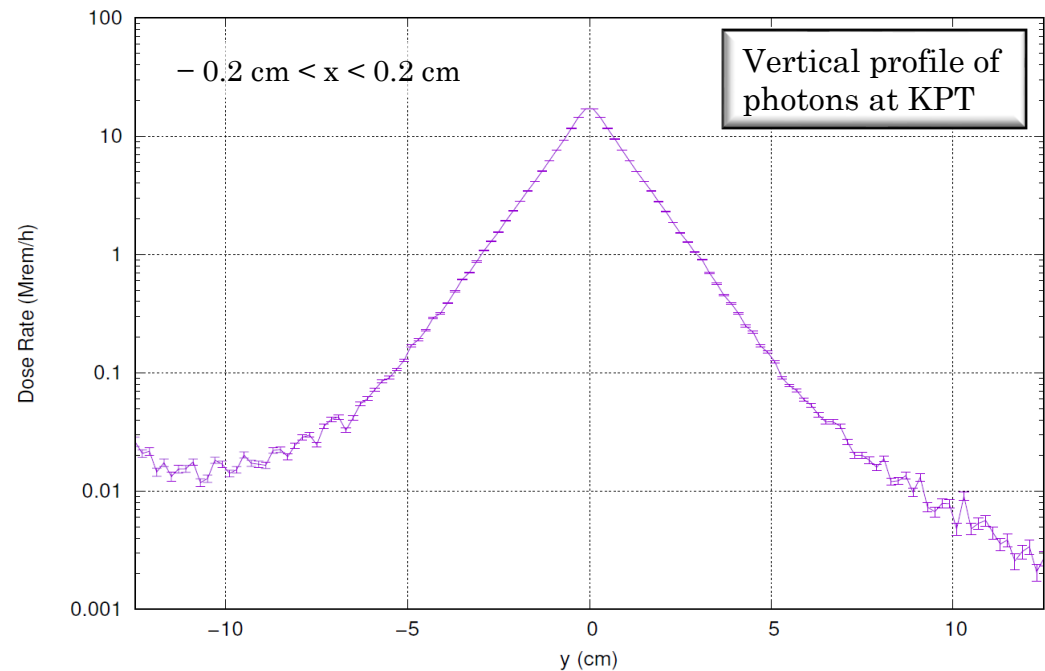
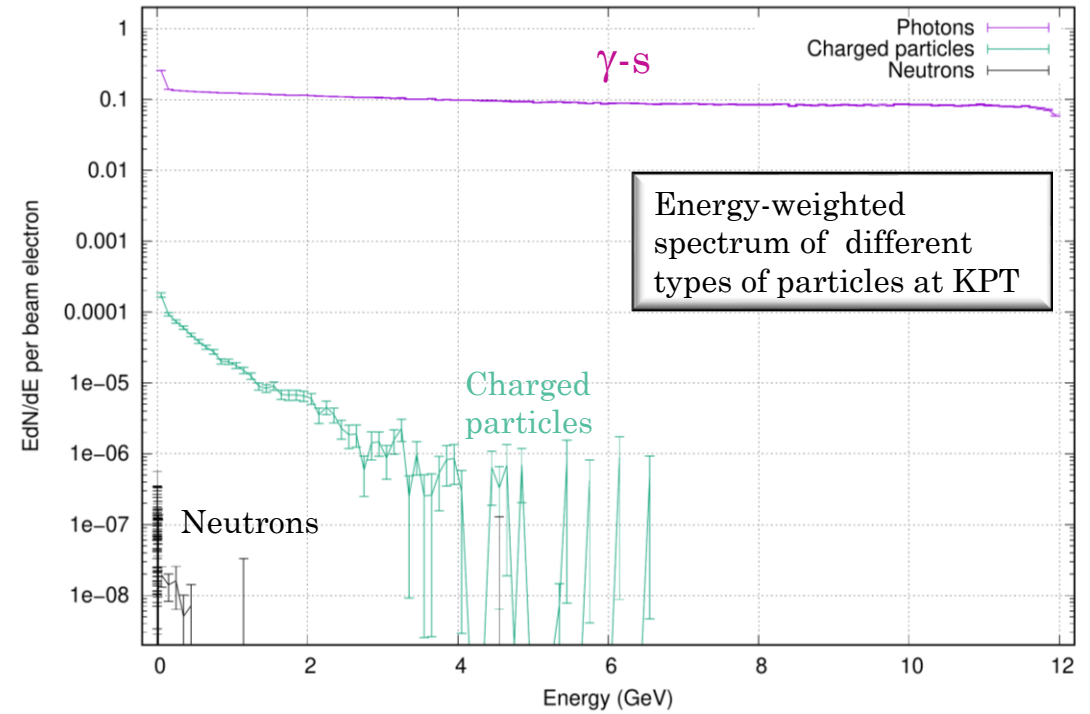
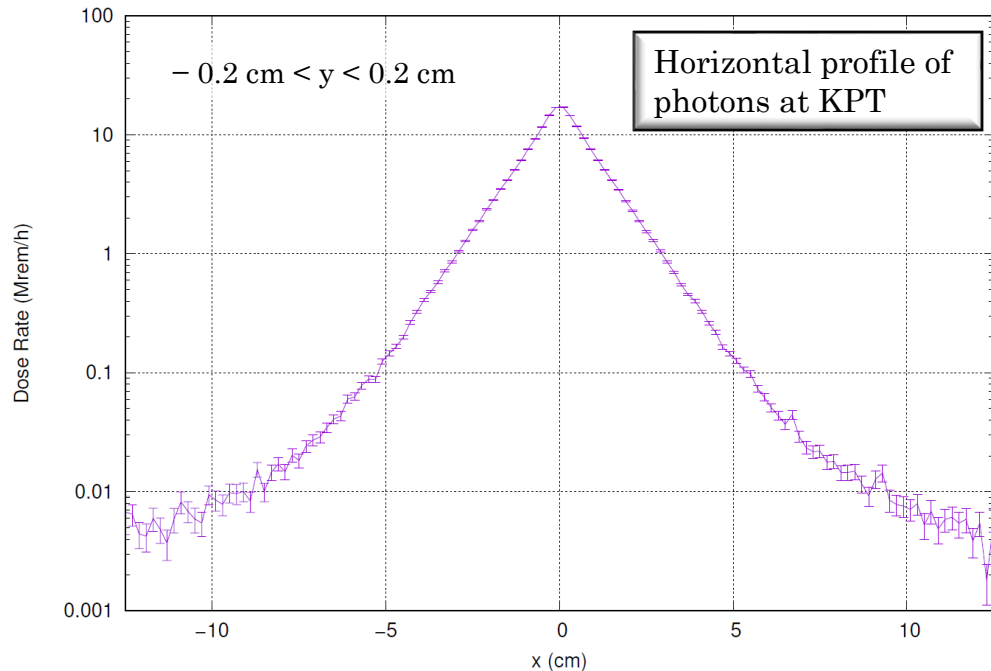



# Radiation Environment

---





# Prompt Dose Rates

- We estimated the prompt dose rates around the Tagger Hall.
  - ❑ More detailed simulation may need to be done.
- The results show that the rates on the surface of the berm will be below 1 mrem/hour.
  - ❑ No civil construction will be needed around Tagger Hall to contain radiation.
- The prompt dose rate around the 10" beam pipe between Tagger Hall and Collimator Cave above the dirt is negligible.
- Prompt dose rate inside Tagger Hall around CPS is ~20 rem/h.
  - ❑ 30 rem/h right at the CPS surface.

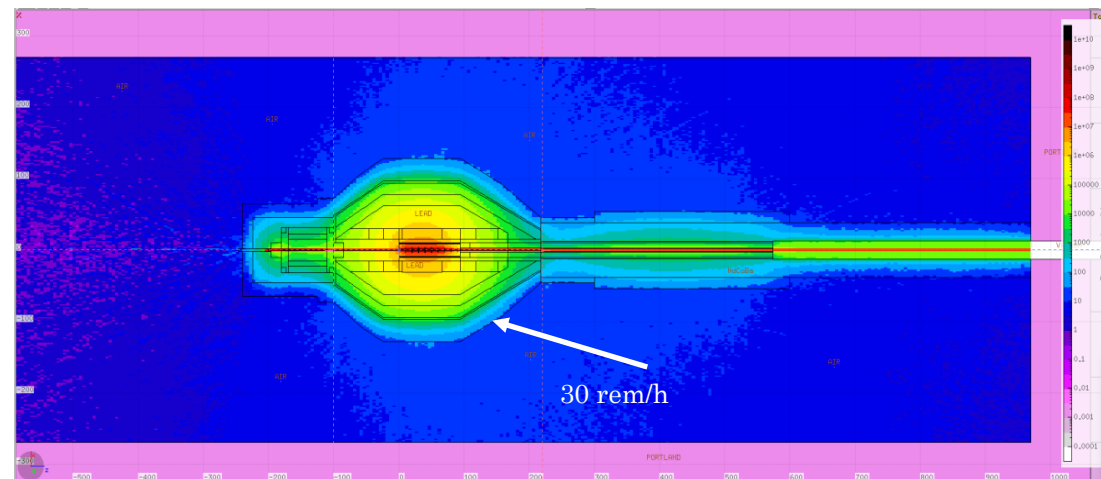
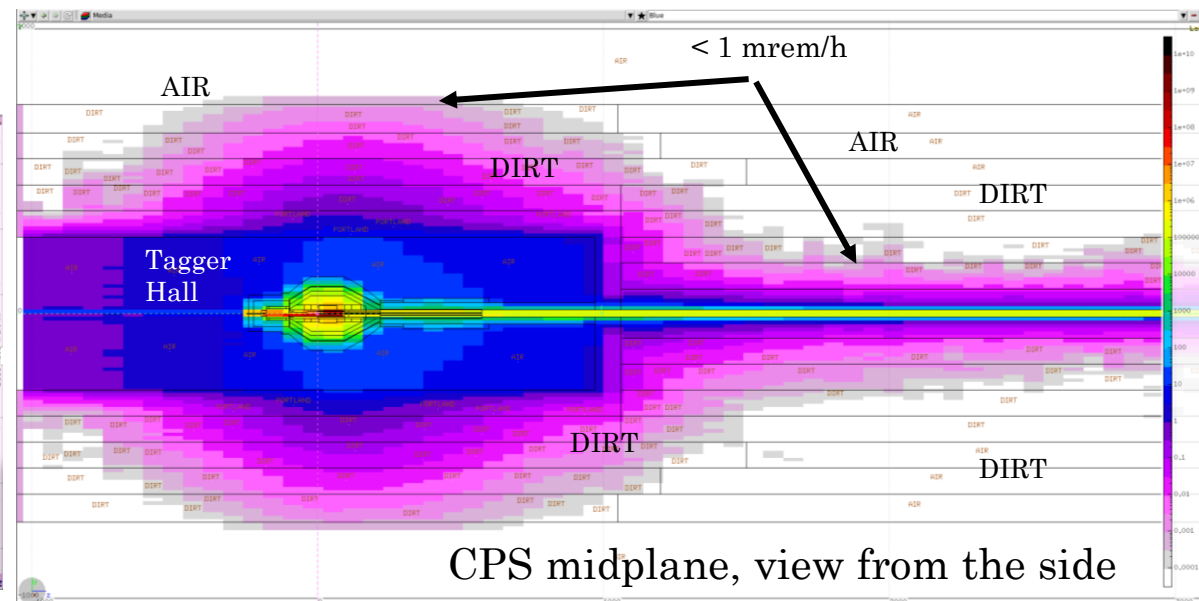
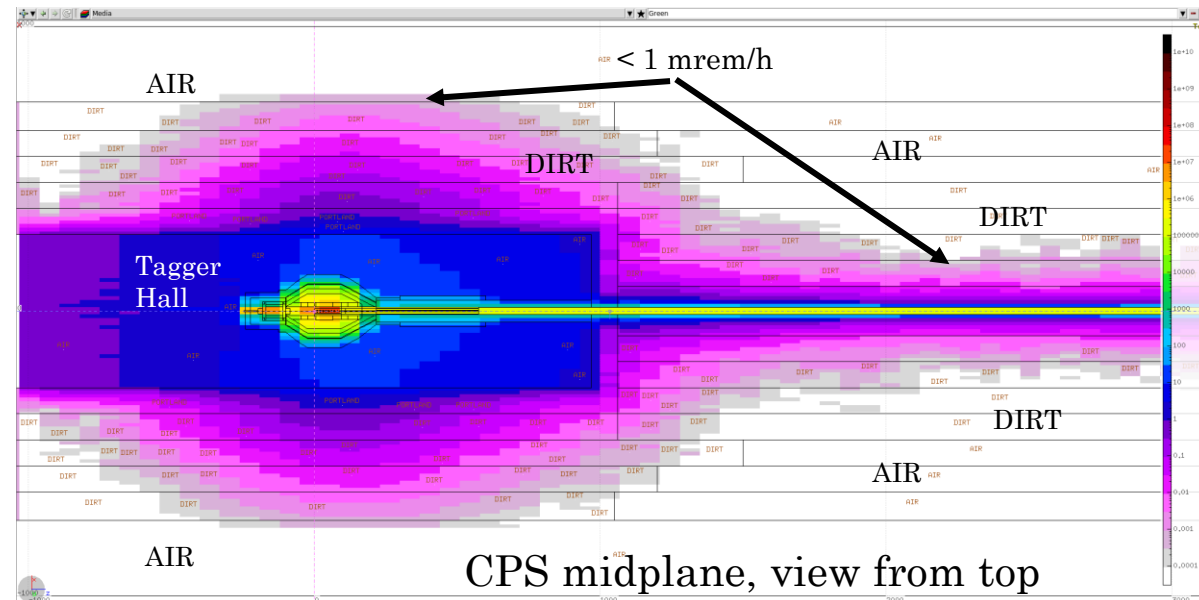

# Activation Dose Rates

- We evaluated activation dose rate after 10000 hours of continuous operations and 1 hour cool-off time.
- The rates outside of CPS are expected to be  $<1$  mrem/h, that is well within JLAB limits.

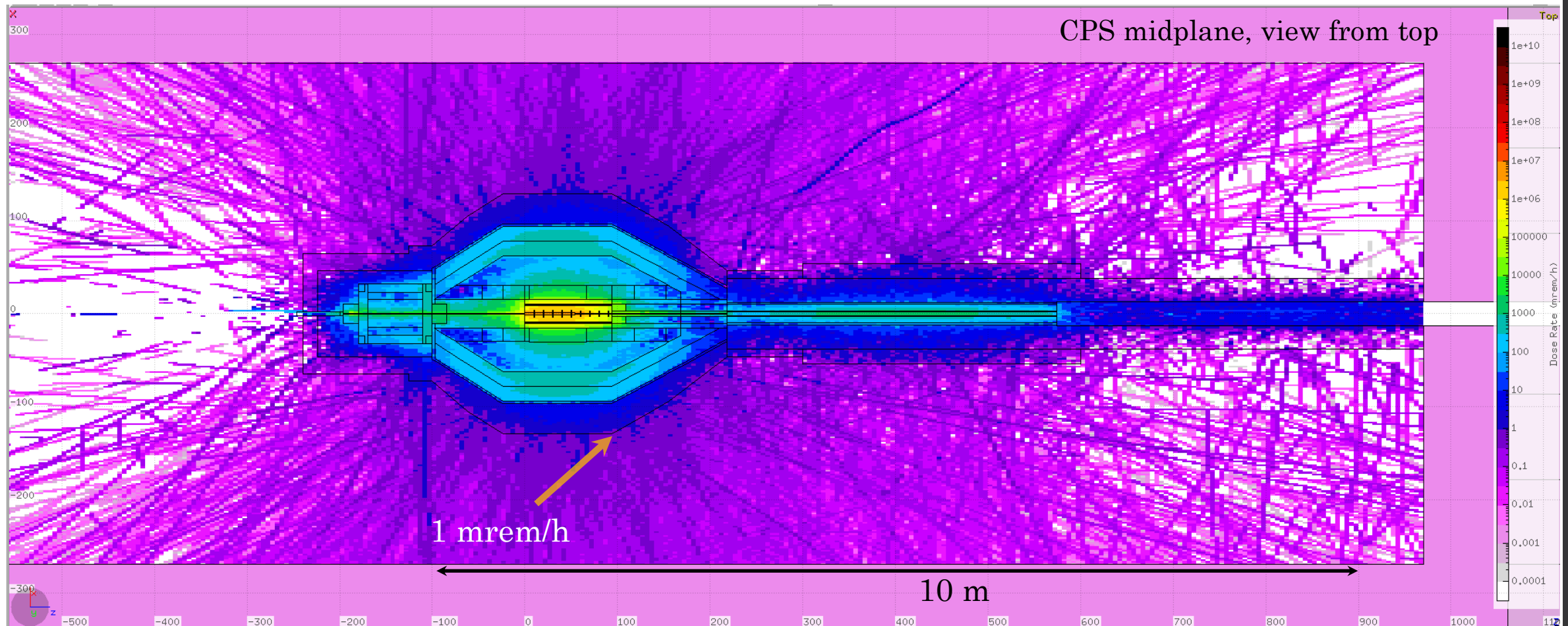

# Accumulated Dose in 10000 hours

- Accumulated doses are evaluated outside of CPS.
  - ❑ We will use this map for equipment installations in the tagger hall.
- CPS is not expected to be disassembled for a very long time.
  - ❑ It can be moved aside to restore GlueX photon beamline.

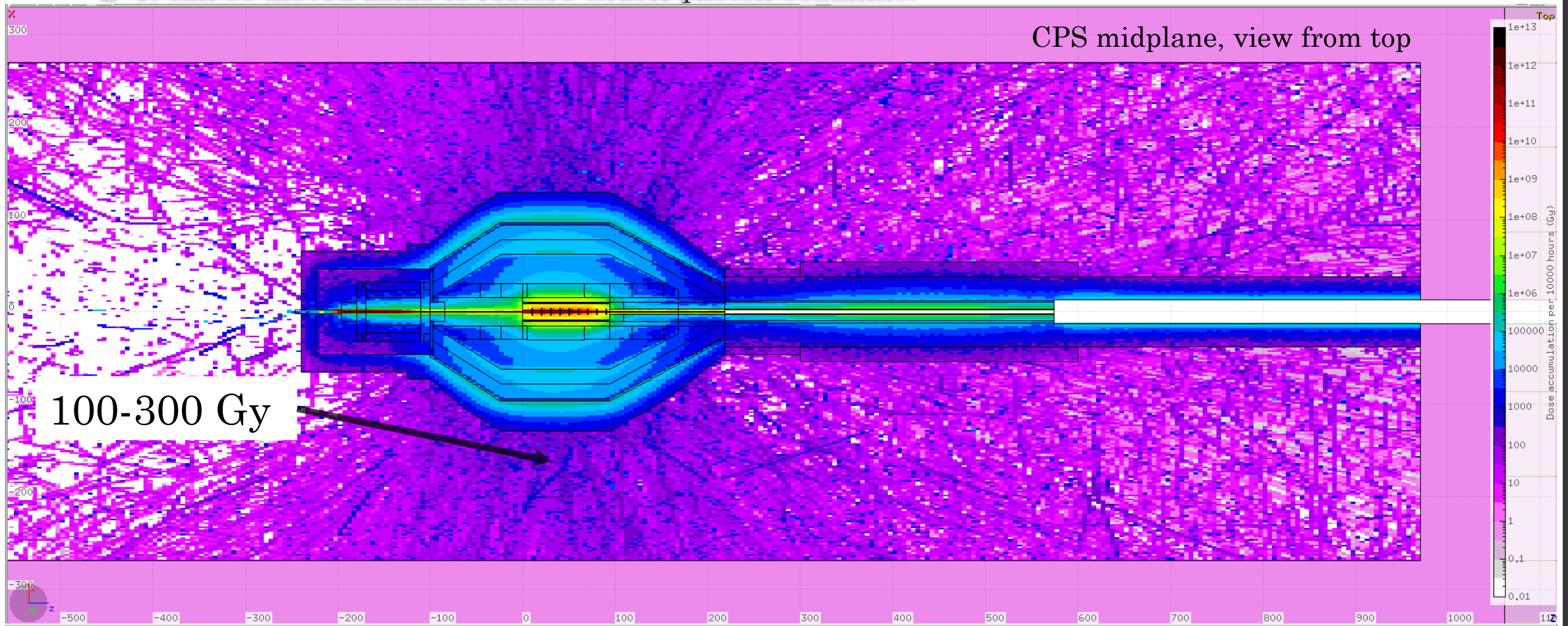



# Accumulated Doses in the Magnets

- Accumulated dose to upstream magnet coils in 10000 hours is expected to be  $3 \times 10^4$  Gy.
  - ❑ Magnet coil insulation made of cyanate ester resins can handle over  $10^6$  Gy dose.
    - Reference: P.E. Fabian, et al “Novel Radiation-Resistant Insulation Systems for Fusion Magnets,” Fusion Engineering and Design, Vol. 61-62, pp. 795-799, 2002
  
- Accumulated dose in the permanent magnet in 10000 hours is expected to be on the level  $\sim 10^7$  Gy.
  - ❑ Hall D strontium ferrite permanent do not change at such a dose.
    - FNAL did not observe any change in B-field after a dose of  $10^7$  Gy.
    - FNAL gave an upper limit of 1% change, as specified in the magnet specs.

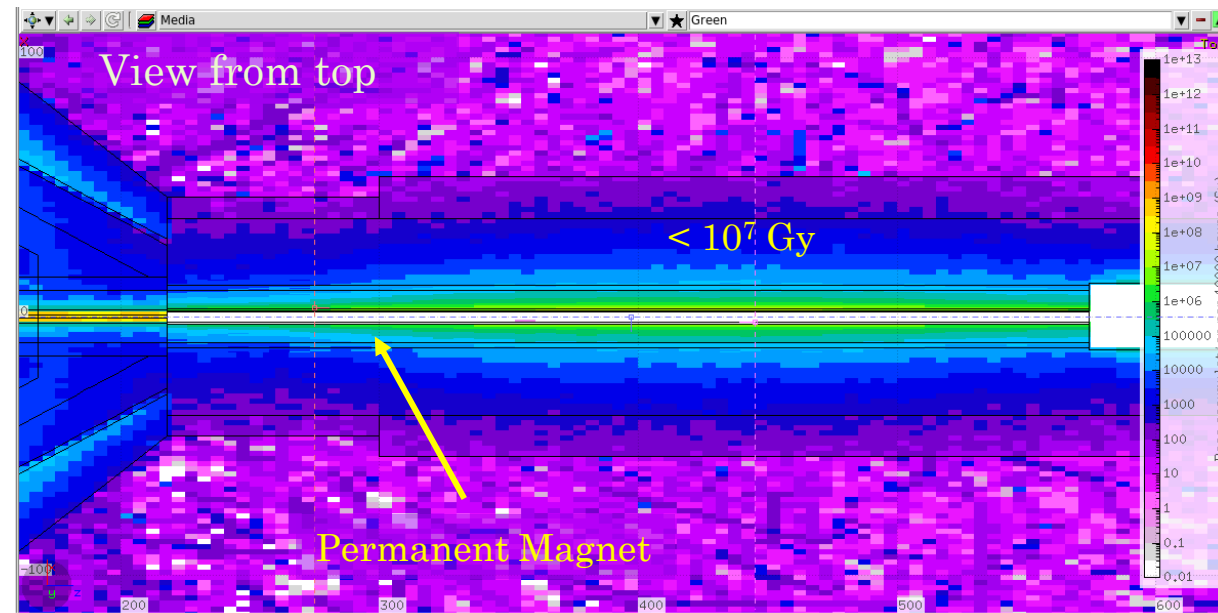
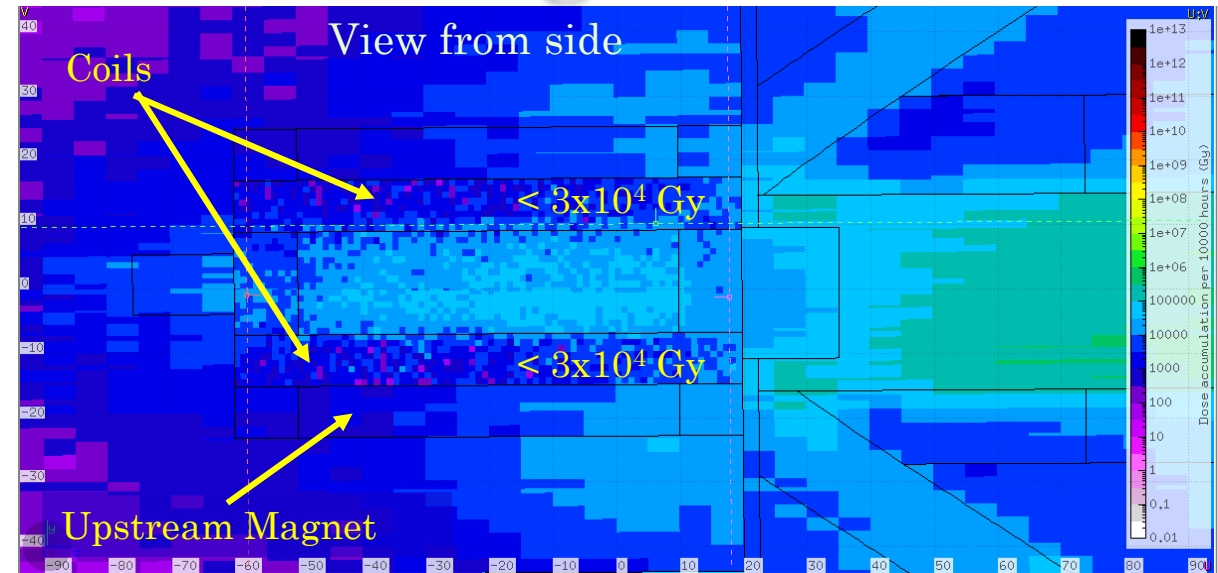

# Absorber Temperature

---

# Power Deposition in the Absorber

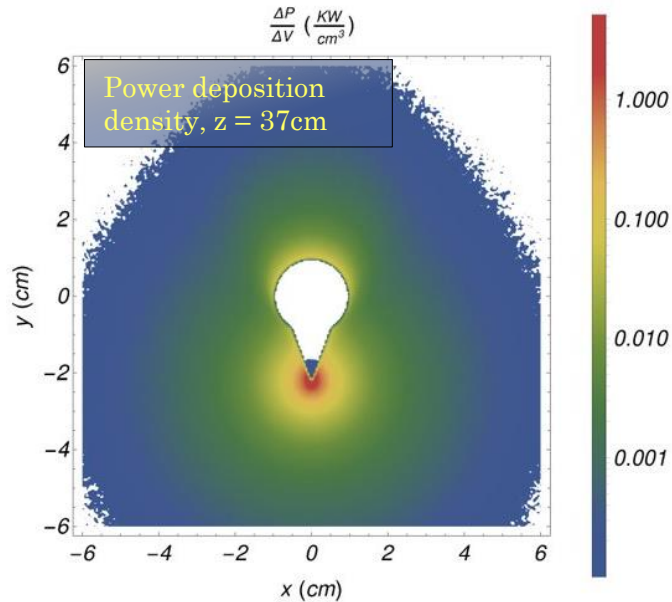

- FLUKA provides an output file with power deposition densities in 3D.
  - ❑ 30M data points inside absorber
- Almost all of the remaining electron beam power (> 98%) is deposited into the copper absorber.
  - ❑ Most likely that only absorber needs cooling.
  - ❑ Must prevent heat transfer from absorber to surrounding volumes.

Color indicates power deposition density (kW/cm<sup>3</sup>), x = 0 plane shown

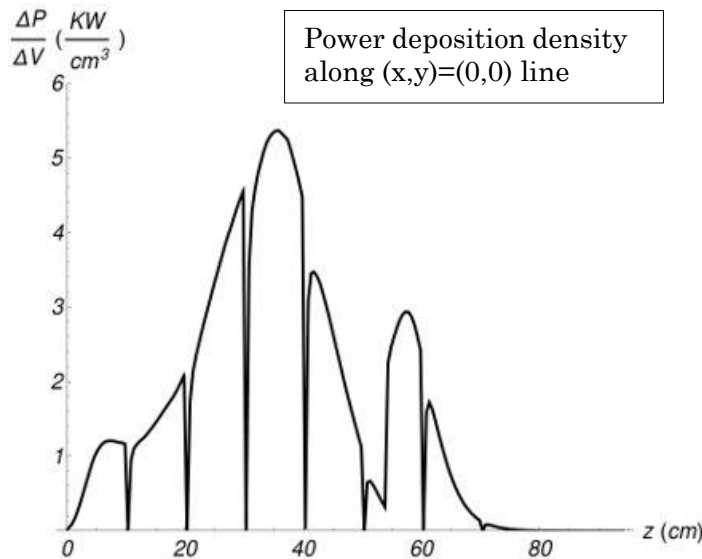
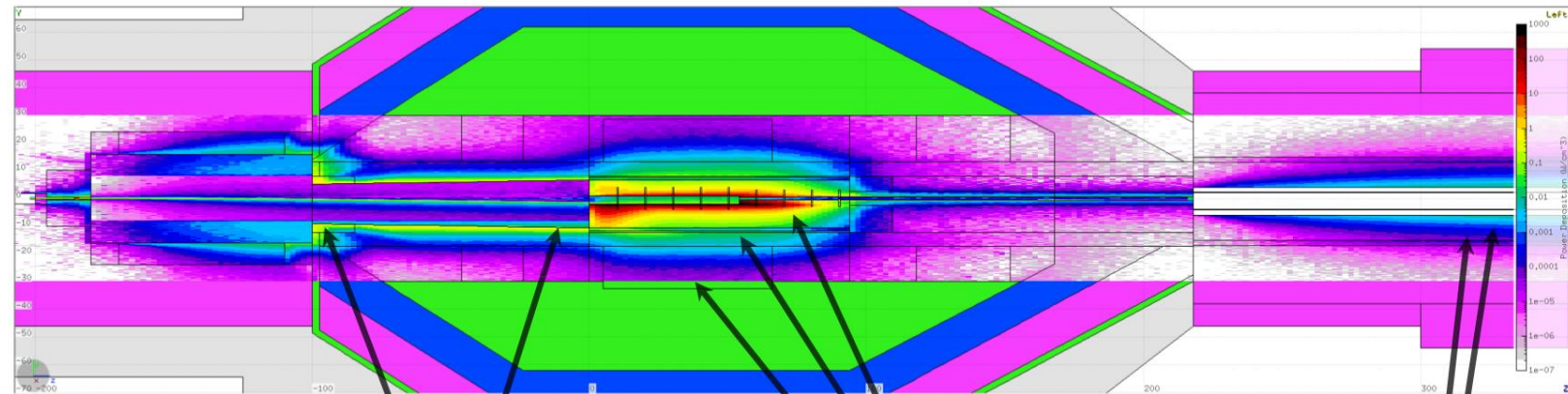

CPS Entry Collar: 34 W  
 CPS Entry Iron: 156 W

Absorber: 53.545 kW  
 Steel Base at Abs: 215 W  
 Lead around Abs: 156 W  
 Perm. Magnet Aluminum: 27 W  
 Perm. Magnet Body: 20 W

**Power inside CPS for 5 μA, 12 GeV beam**

All other parts get less than 20 W each

# Temperature

- Temperature calculations in the “isolated” absorber is done using power deposition maps obtained using FLUKA.
- Two independent calculations are done by two people using two different software packages:
  - ❑ ANSYS software, popular among engineers
  - ❑ Wolfram Mathematica software, popular among scientists
  - ❑ The results are in a good agreement.
- The temperature at the hotspot is expected to be  $\sim 230\text{ }^{\circ}\text{C}$  at nominal beam parameters.
- There is no high temperature at the outer boundaries of the absorber, except the front side.
  - ❑ Still need to perform ANSYS evaluation for the whole CPS.

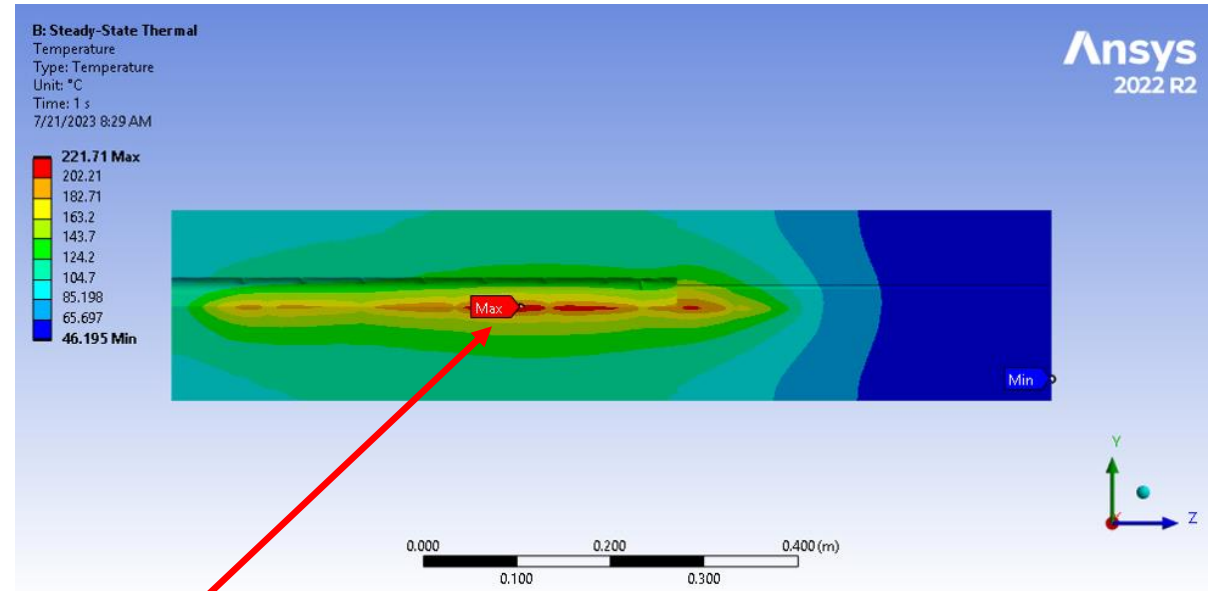

$T_{\max} \approx 222\text{ }^{\circ}\text{C}$

$T_{\max} \approx 230\text{ }^{\circ}\text{C}$

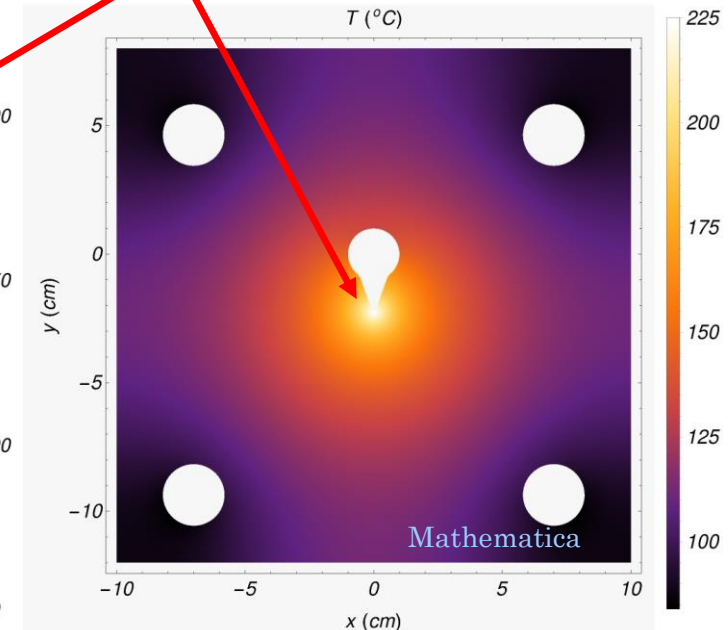
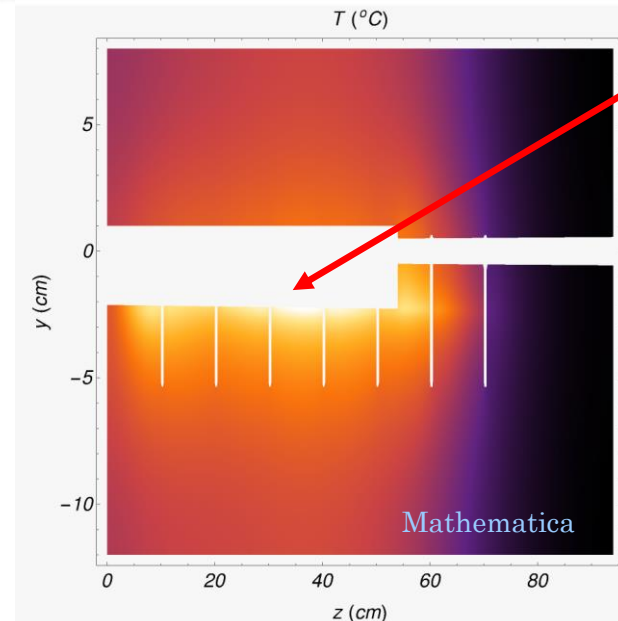
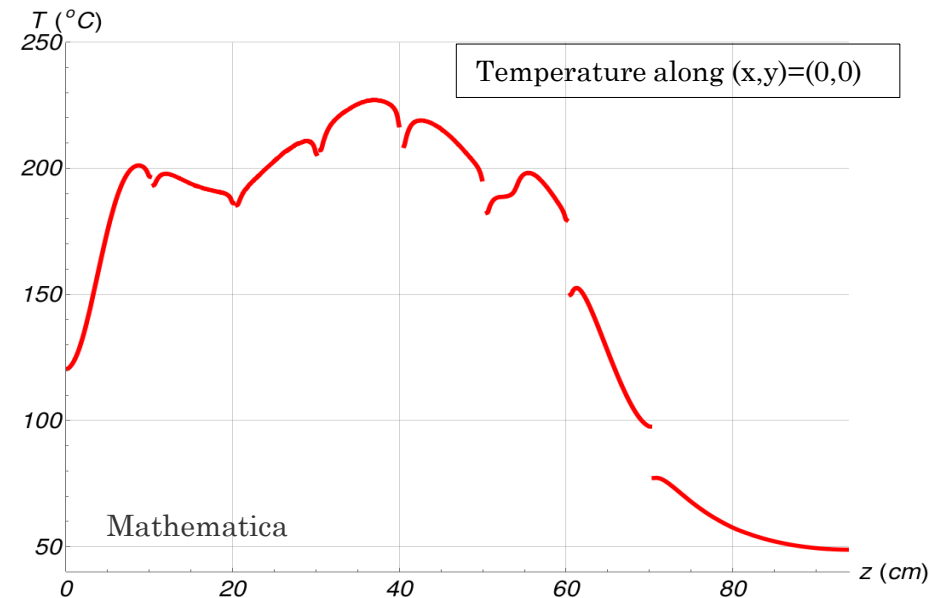



# Temperature vs Beam Conditions

- Temperature in the copper core depends on the beam conditions.
- Expected temperature range is  $200\text{ }^{\circ}\text{C} < T_{\text{max}} < 300\text{ }^{\circ}\text{C}$ .
- Deformations and stresses are being studied in ANSYS. See talk by Tim Whitlatch.
- Multiple beam conditions has been simulated with FLUKA and the resulting temperature distributions evaluated.
- Temperatures in all studied conditions appear to be manageable.
  - ❑ We will impose restrictions on the beam conditions.

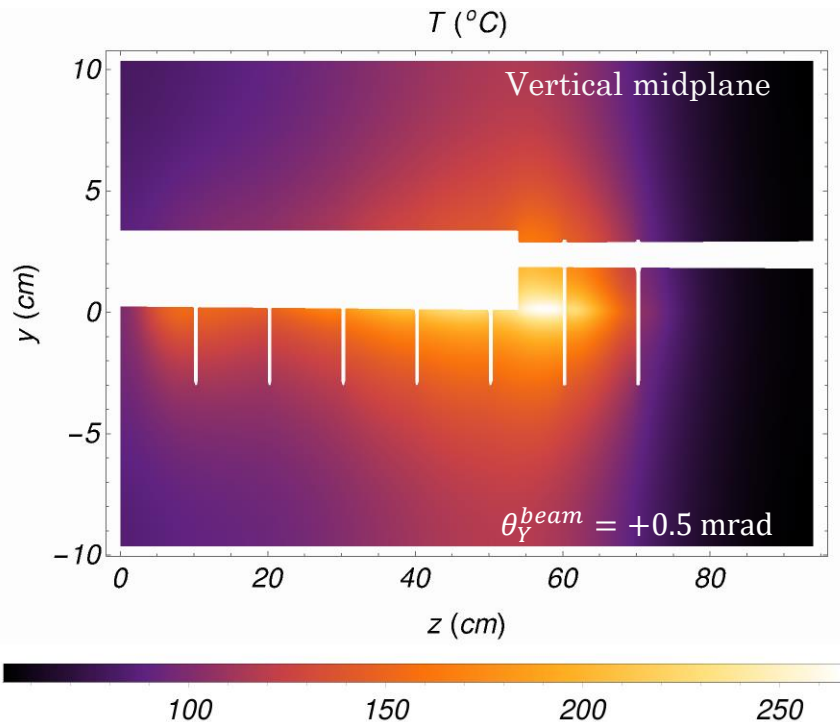

Test Configuration Name	$Z_{\text{max}}$ (cm)	$T_{\text{max}}$ ( $^{\circ}\text{C}$ )	$T_{\text{cold}}$ ( $^{\circ}\text{C}$ )
All Nominal	37	230	100
$\sigma^{(x,y)}_{\text{beam}} = 0.33\text{ mm}$	43	290	105
$\sigma^{(x,y)}_{\text{beam}} = 1.5\text{ mm}$	8.5	245	100
97% B-field	56.5	245	100
103% B-field	33	240	100
-1mm shift in Y	8	265	110
+1mm shift in Y	57	265	105
-0.5mrad angle in Y	8.5	265	110
+0.5mrad angle in Y	58	275	105
+1mm shift in X	8.2	260	100
+0.5mrad angle in X	8	260	100



# Summary

---

# Electron Beam Requirements

- It is important to have a good beam on the radiator.
  - ❑ Excessive radiation in Tagger Hall.
  - ❑ Higher Temperatures in the absorber.
- We found that beam rastering will not be necessary.
  - ❑ We will need to make sure that beam profile is wide using wire scans at CPS.
- Install a girder just upstream of CPS with:
  - ❑ BCM to measure the beam current,
  - ❑ BPM to measure beam positions,
  - ❑ Wire scanner for beam widths.
- FSD trips on
  - ❑ Large electron beam positions excursions,
    - Use a collar and ion chambers.
  - ❑ Electron beam angle excursion,
    - Measure photon beam position at KPT.
  - ❑ Magnet current deviations.
    - Use power supply ADCs.
- Keep Hall D radiator scanner for the halo measurement.

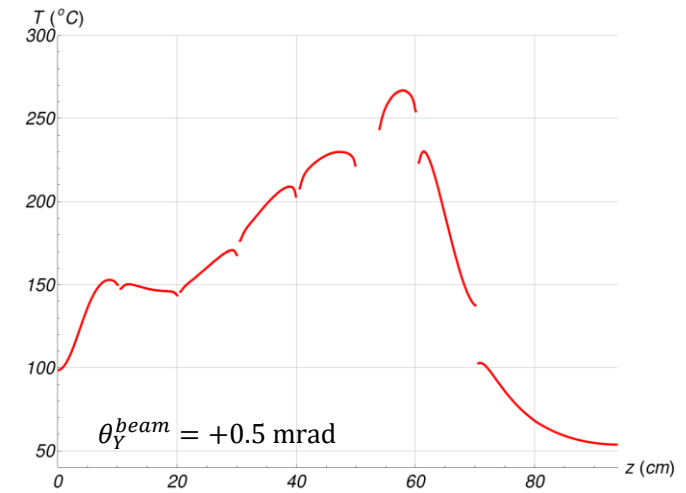

Parameter	@ CPS Radiator	@ KPT
Beam Current	$50 \text{ nA} \leq I_B \leq 5 \text{ }\mu\text{A}$	N/A
Beam Size	$0.5 \text{ mm} \leq \sigma \leq 1.5 \text{ mm}$	$\sigma \leq 1 \text{ cm}$
Beam stability (@ 1 Hz)	$\sigma \leq 0.2 \text{ mm}$	$\sigma \leq 2 \text{ mm}$
FSD is tripped at	$ \Delta x  > 1 \text{ mm}$ or $ \Delta y  > 1 \text{ mm}$	$ \Delta x  > 1 \text{ cm}$ or $ \Delta y  > 1 \text{ cm}$
Beam halo (halo-to-peak)	$< 10^{-4}$ at $r > 5\sigma$	N/A

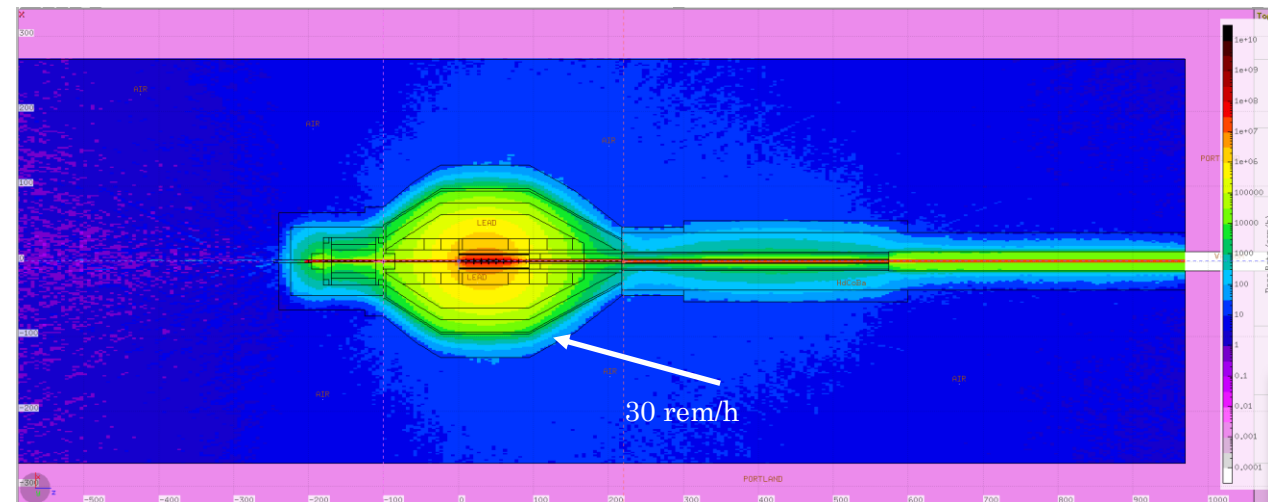

# Electron Beam Requirements

- It is important to have a good beam on the radiator.
  - ❑ Excessive radiation in Tagger Hall.
  - ❑ Higher Temperatures in the absorber.
- We found that beam rastering will not be necessary.
  - ❑ We will need to make sure that beam profile is wide using wire scans at CPS.
- Install a girder just upstream of CPS with:
  - ❑ BCM to measure the beam current,
  - ❑ BPM to measure beam positions,
  - ❑ Wire scanner for beam widths.
- FSD trips on
  - ❑ Large electron beam positions excursions,
    - Use a collar and ion chambers.
  - ❑ Electron beam angle excursion,
    - Measure photon beam position at KPT.
  - ❑ Magnet current deviations.
    - Use power supply ADCs.
- Keep Hall D radiator scanner for the halo measurement.

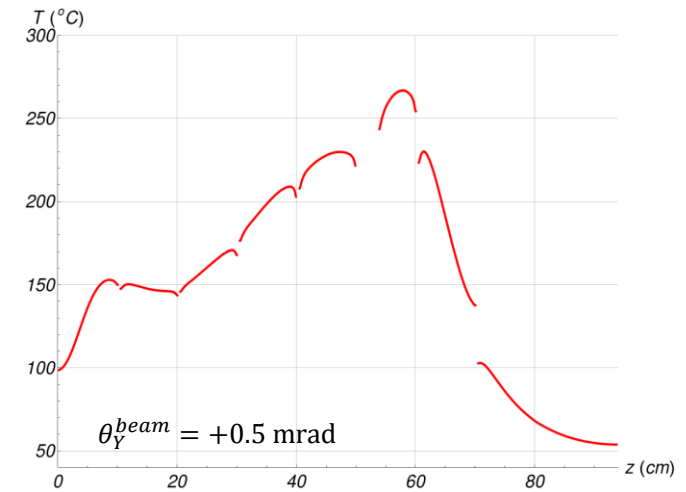

Parameter	@ CPS Radiator	@ KPT
Beam Current	$50 \text{ nA} \leq I_B \leq 5 \text{ }\mu\text{A}$	N/A
Beam Size	$0.5 \text{ mm} \leq \sigma \leq 1.5 \text{ mm}$	$\sigma \leq 1 \text{ cm}$
Beam stability (@ 1 Hz)	$\sigma \leq 0.2 \text{ mm}$	$\sigma \leq 2 \text{ mm}$
FSD is tripped at	$ \Delta x  > 1 \text{ mm}$ or $ \Delta y  > 1 \text{ mm}$	$ \Delta x  > 1 \text{ cm}$ or $ \Delta y  > 1 \text{ cm}$
Beam halo (halo-to-peak)	$< 10^{-4}$ at $r > 5\sigma$	N/A

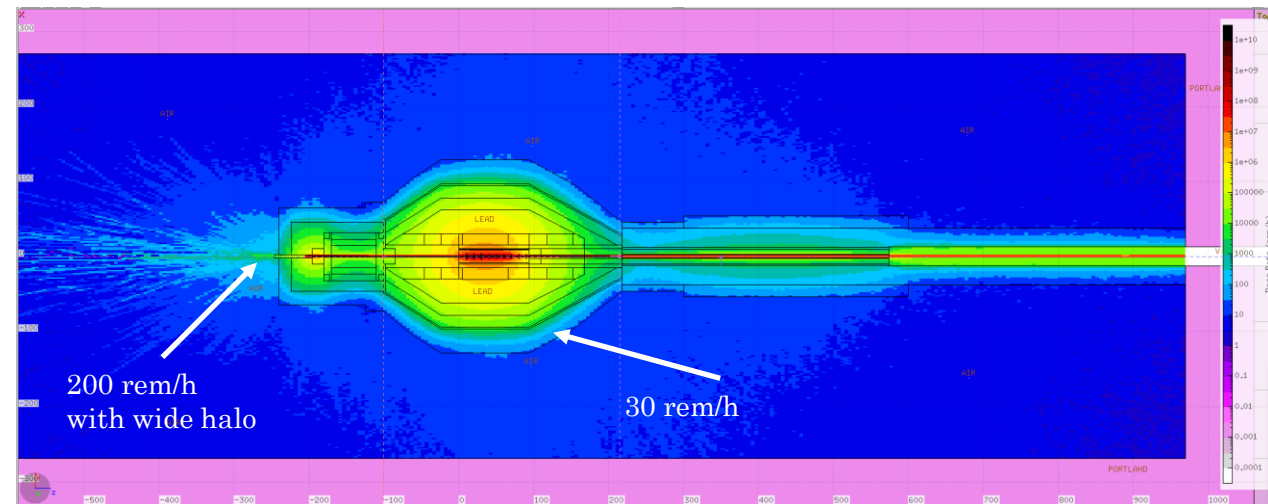

# Conclusions

- We developed a conceptual design of CPS for Hall D.
  - ❑ It will provide photon beam at KPT that would meet KLF requirements.
  - ❑ We will use a movable platform to be able to restore GlueX beamline.
- No major R&D is anticipated for the design and construction of CPS.
  - ❑ Need to optimize CPS and develop engineering design.
- We performed FLUKA simulations to estimate the radiation levels around CPS.
  - ❑ Radiation environment should be similar or better than GlueX would have at 5 $\mu$ A.
  - ❑ No civil construction is needed in tagger hall.
- We are in contact with Accelerator Division regarding beam requirements for CPS.
  - ❑ No show-stoppers are identified.
- Working on optimization of the basic design.
  - ❑ Check radiation environment with newer versions of FLUKA.
- Engineering design is the next step.



# Potential Problems and Mitigations

- At very large vertical angles ( $500 \mu\text{rad}$ ), the beam can penetrate deep into CPS and cause somewhat elevated temperatures ( $275 \text{ }^\circ\text{C}$ ).
  - ❑ The radiation environment is probably not going to be affected much.
  - ❑ The photon beam position needs to be monitored and used in the beam interlock.
- At large horizontal shifts ( $\sim 1 \text{ mm}$ ), the beam can impact the upstream wall of the absorber missing the keyhole and thus cause high temperatures ( $300 \text{ }^\circ\text{C}$ ).
  - ❑ The radiation environment is probably not going to be affected much.
  - ❑ Beam position need to be monitored and beam needs to be shut off at large excursions.

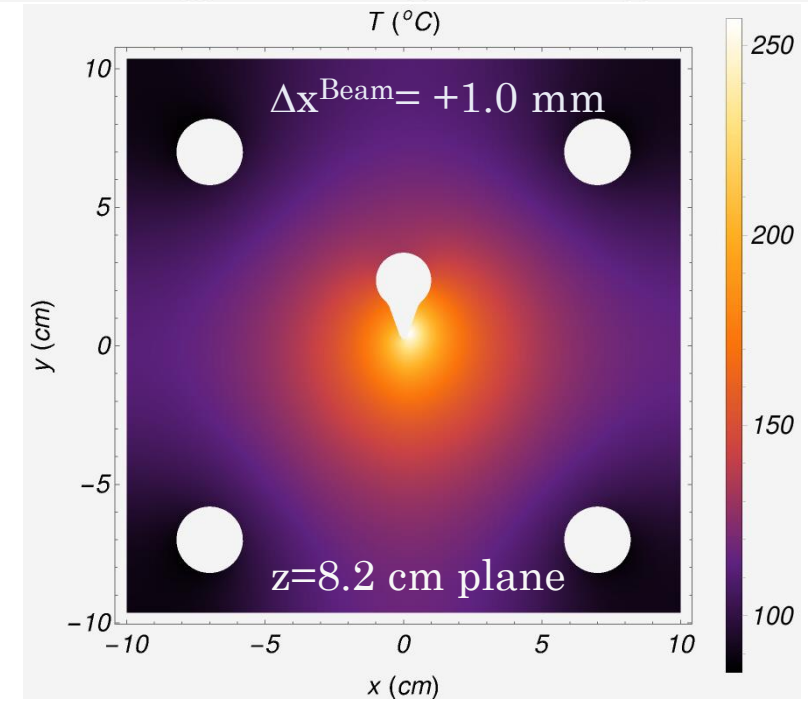
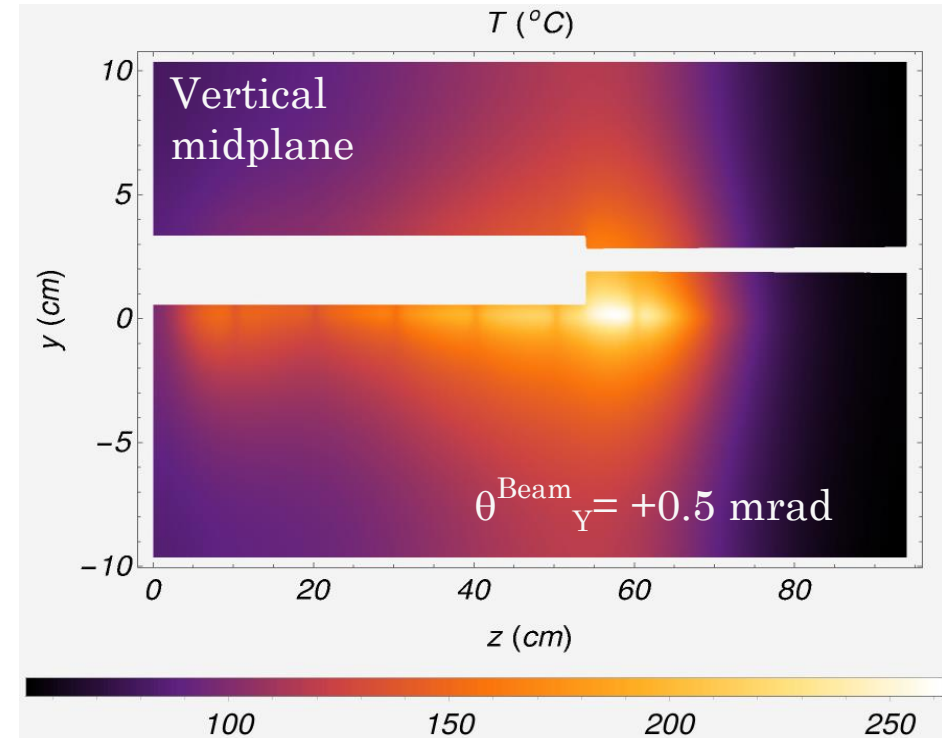



# Cost and Schedule

- The total weight estimate for the new installations in Tagger Hall is ~90??? metric tons.
  - ❑ According to Facilities Management, Tagger Hall can easily accommodate 100 metric tons.
- Total cost of the CPS, including magnet and PS, is ~\$1M.
  - ❑ Electron beam instrumentations upstream of CPS will be extra.



# CPS Location in Tagger Hall



➤ Probably not needed

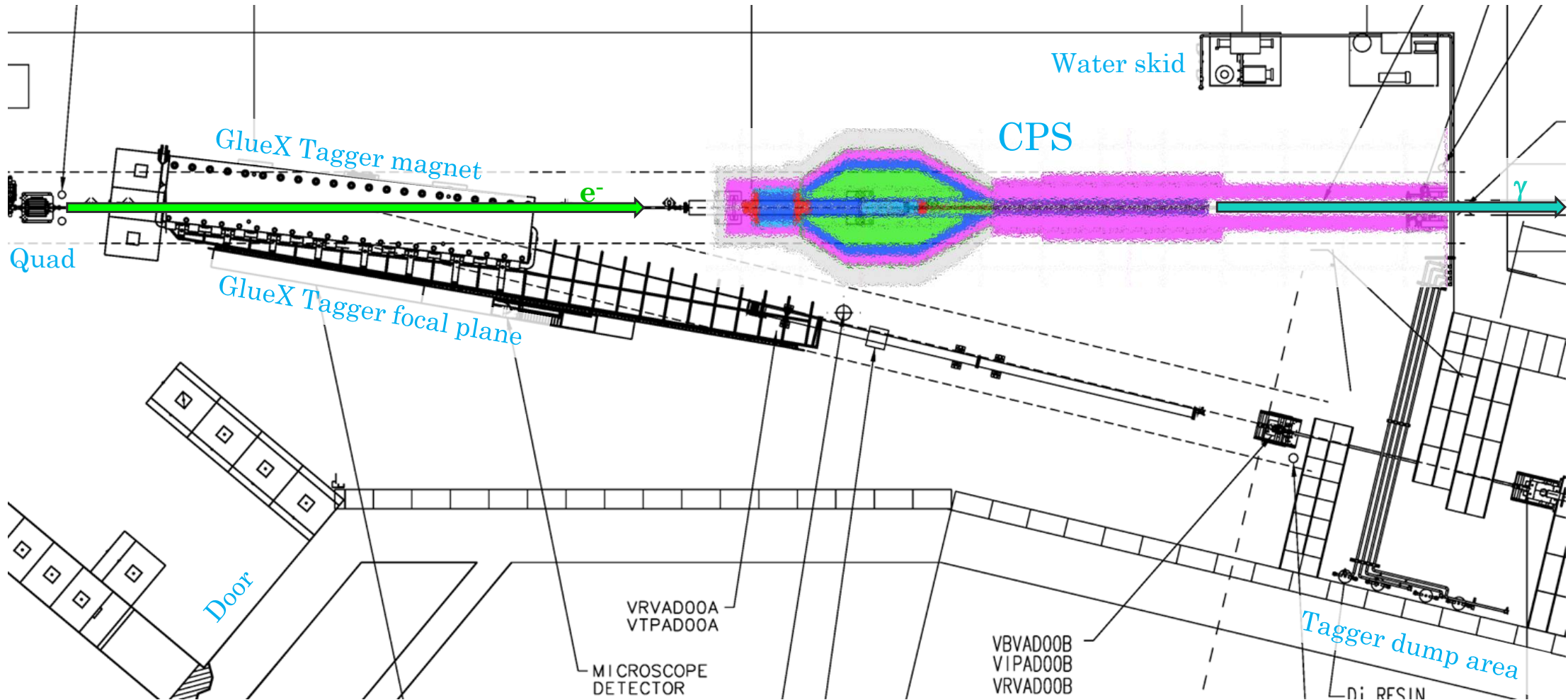

8/2/2023

KLFF ERR-1 Review

Hovanes Egiyan

➤ fsgfd

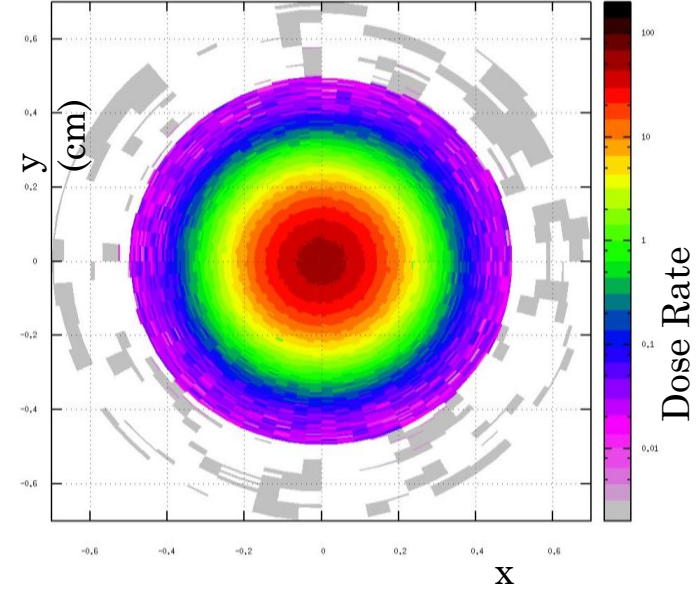

8/2/2023

KLF ERR-1 Review

Hovanes Egiyan

Grem / hr