

Cryotarget for KLF

Chris Keith
JLab Target Group

Outline

Update on Hall D Cryotarget

GlueX

eta-Primakoff

Short Range Correlations

Modifications needed for KLF

Schedule

Summary

The Hall D Cryotarget

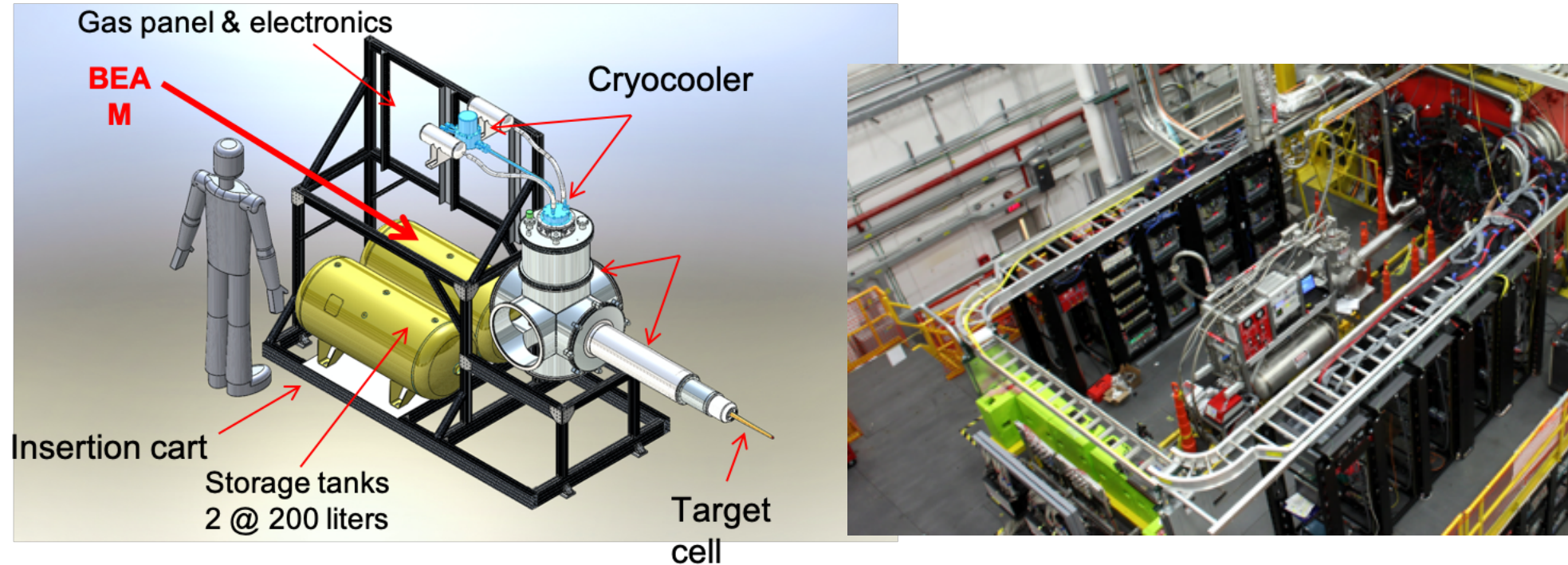

A cryocooler-based liquid hydrogen target constructed for GlueX

- Modified for PrimeX in Spring 2019 (liquid helium & beryllium)
- Utilized for GlueX (LH2) in Fall 2019, Spring & Summer 2020

The Hall D Cryotarget

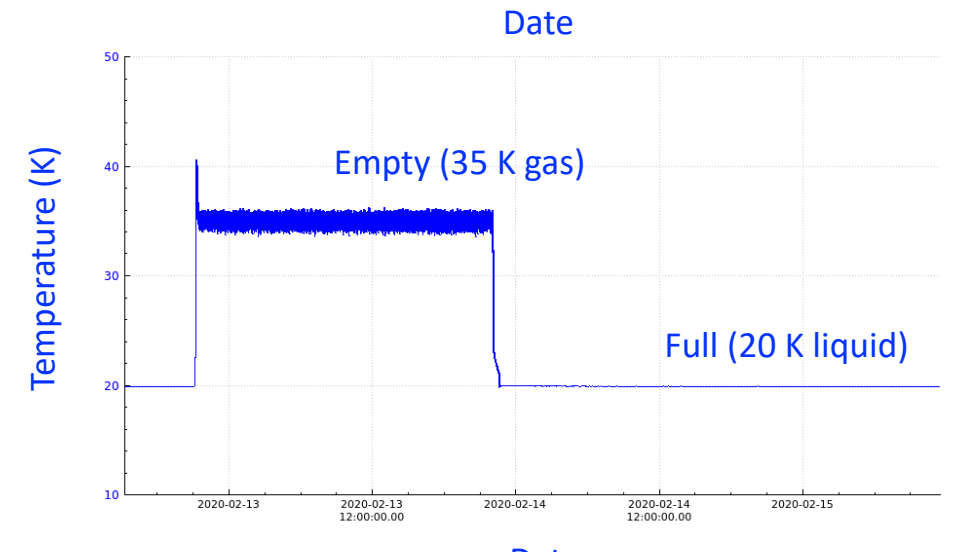
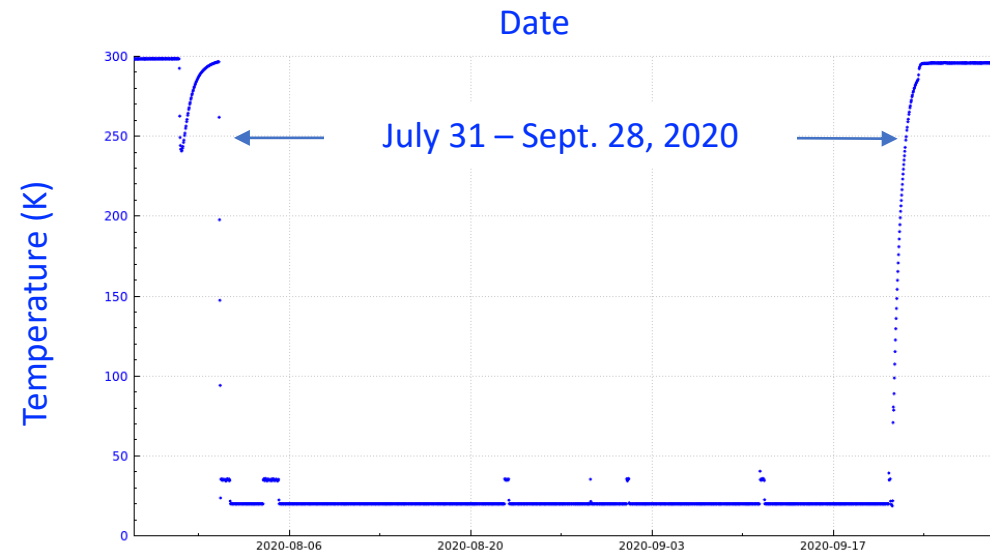
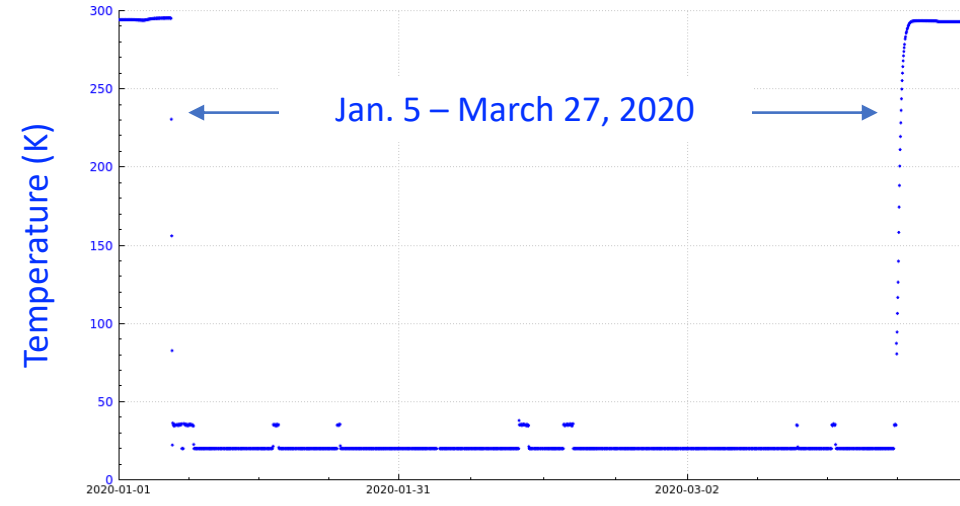
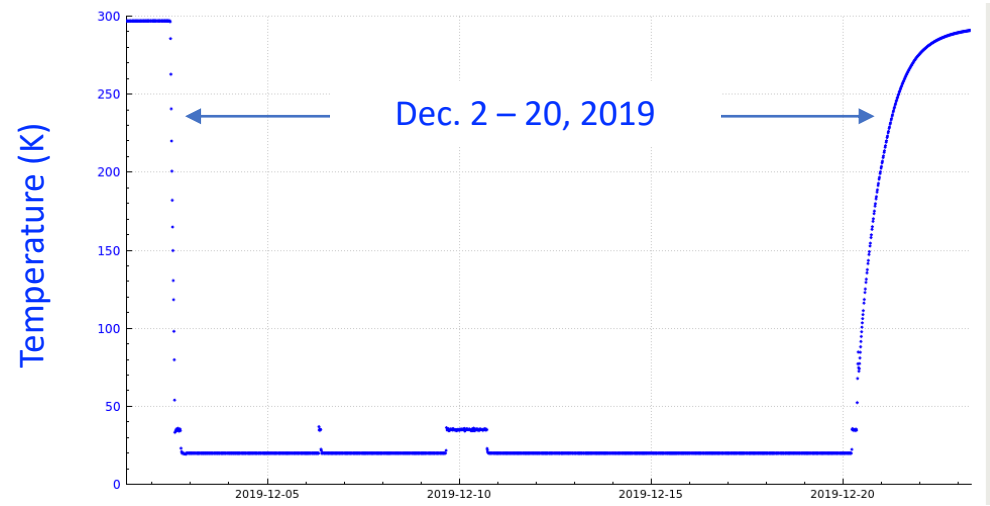

The Hall D Cryotarget

June 2021: **E12-10-011** (eta-Primakoff)
August 2021: **E12-19-003** (Short Range Correlations)

Liquid helium
Liquid deuterium
Carbon foils

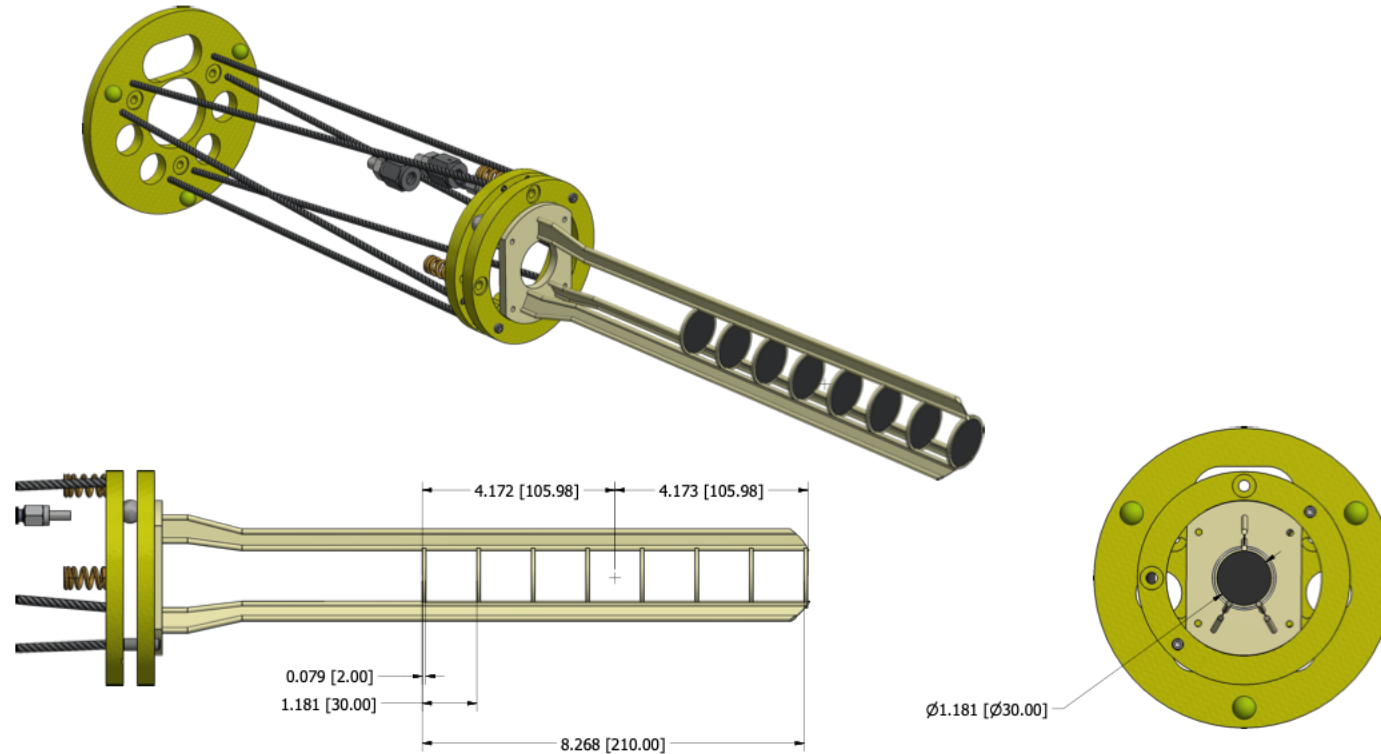

Carbon foil target design by James Brock

The KLF Cryotarget

Target Requirements for K-long physics

- Target materials: LH₂ and LD₂
- Target dimensions: 40 cm x 6 cm dia. (1.1 L)
- Fluid density precision: \pm a few percent (some boiling ok)
- Beam heating: negligible
- z location: same as GlueX

The KLF Cryotarget

Target Requirements for K-long physics

- Target materials: LH₂ and LD₂
- Target dimensions: **40 cm x 6 cm dia. (1.1 L)**
- Fluid density precision: \pm a few percent (some boiling ok)
- Beam heating: negligible
- z location: same as GlueX

The only new requirement (so far) for the K-long target is a substantially larger target cell.

The KLF Cryotarget

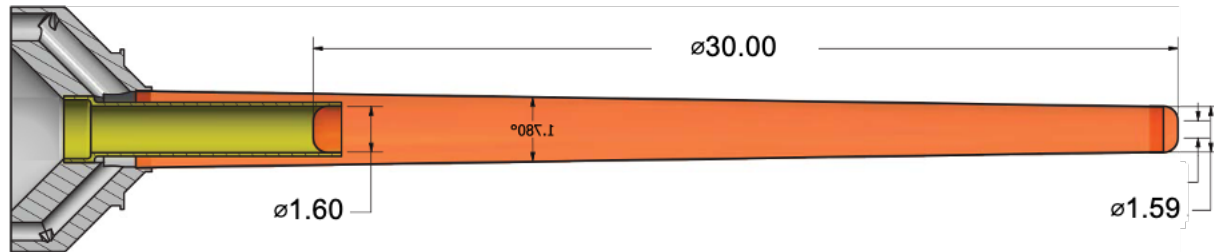

GlueX cell: ~0.1 liter

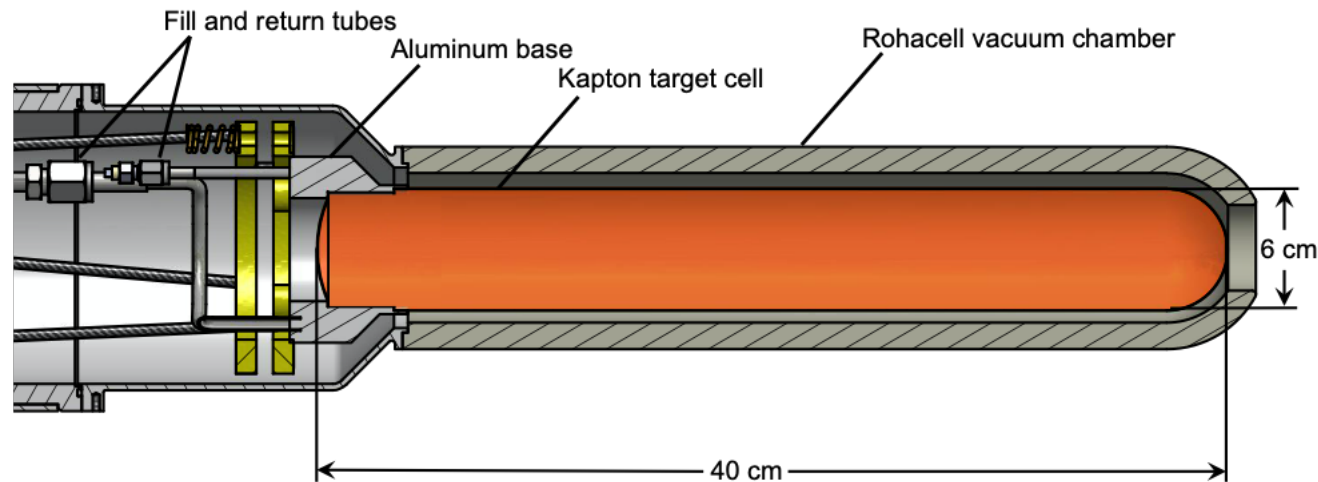

K-Long cell: ~1.1 liter

Comparison to other liquid hydrogen targets at JLab

Hall A/C: ~7 liters

Qweak: ~60 liters

Moller: ~60 liters

The KLF Cryotarget

The larger cell volume will require storing about 1500 STP liters of H₂ gas.

Current storage volume: 400 liters

KLF storage pressure: 3.8 atm (56 psia, not too bad)

2 x 200 liter
Hydrogen tanks



The KLF Cryotarget

However, this will require a stronger cell design

Rupture Strength

The GlueX cell has a diameter of 2 cm, and a maximum allowed pressure of 42 psi.

This will drop to about 14 psi if the cell diameter increases to 6 cm.

This can only be mitigated by using thicker/stronger cell walls.

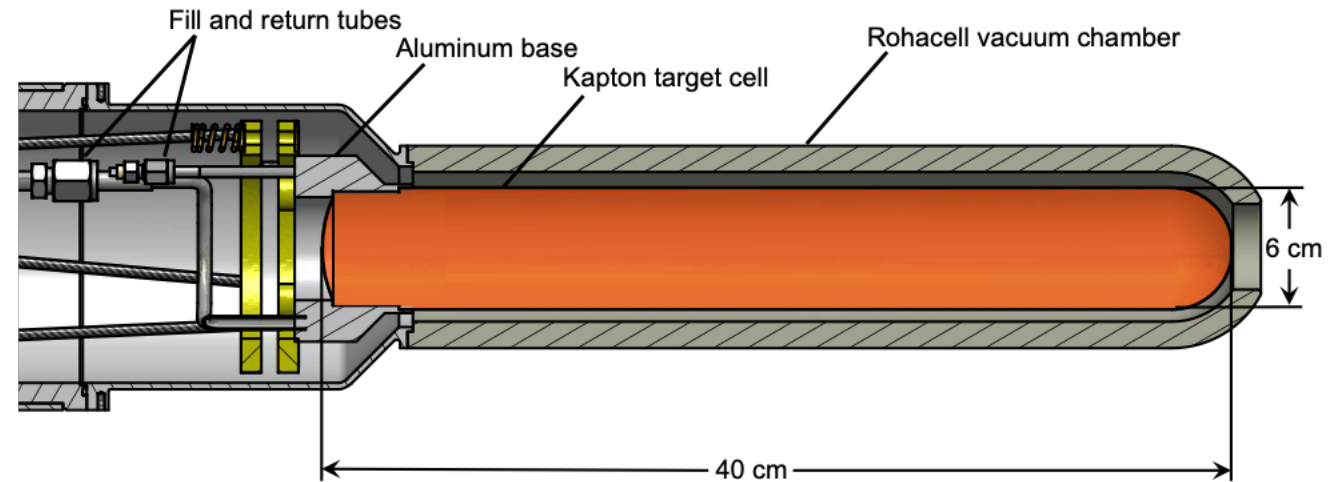

The KLF Cryotarget

Rupture Strength

For example, the liquid hydrogen target cells in Halls A & C are machined from Al-7075 with ~0.1 mm entrance & exit windows.

These are rated for 100 psi.

We will probably pursue similar designs for the KLF target.

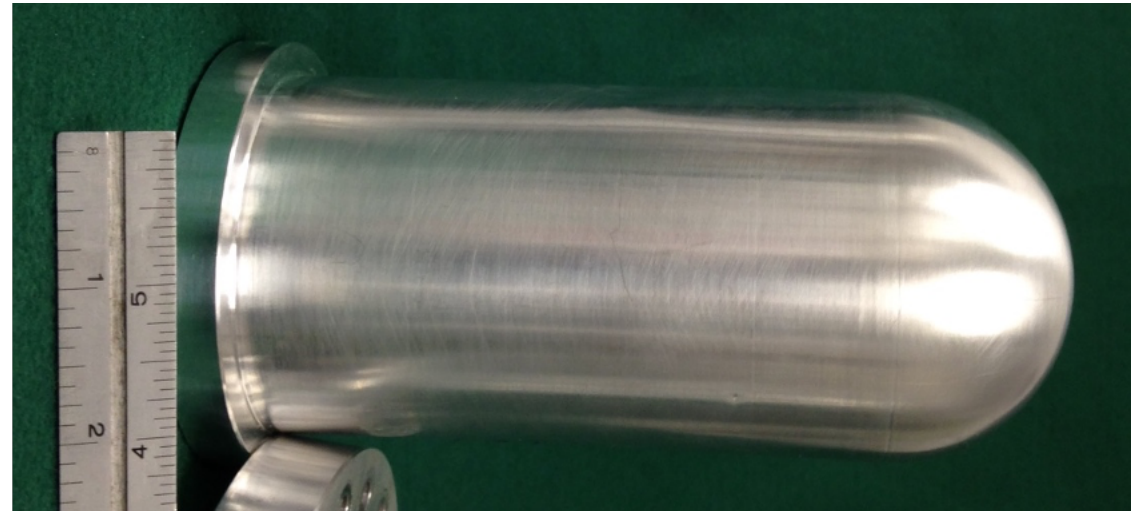

The KLF Cryotarget

Deuterium vs Hydrogen

Deuterium condenses at a higher temperature than hydrogen, so this will not be a problem.

Deuterium has a slightly higher liquid-to-gas expansion ratio, so this has to be taken into consideration when analyzing the pressure safety requirements.

Without significant modifications, we will not be able to store both deuterium and hydrogen gases simultaneously.

- Rapid/frequent switching between LD2 & LH2 will not be possible.

Schedule

The Target Group never has only one ongoing projects – usually three or more, in addition to maintaining systems currently in service.

Our priorities are based on the beam schedule (real & speculated) and the project's anticipated level of difficulty

Our near-term projects:

- Longitudinally polarized target (Hall B)
- Cryotarget (Hall B)
- Møller Cryotarget (Hall A)
- Transversely polarized target (Hall C)

Our long-term projects (so far):

- Polarized ^3He (Hall B)
- Tritium target (Hall B)
- PRad-II target (Hall B)
- Frozen spin target (Hall D)
- SoLID cryotarget (Hall A)



The KLF cryotarget falls into this category

- Not on the schedule
- Modifications should be relatively straightforward
- 1—2 years of effort
- 3—6 months access to GlueX target

Summary

The GlueX cryotarget has proven (so far) to be a very reliable and low-maintenance apparatus/

An initial design study shows that a larger target cell can be accommodated within the existing vacuum chamber.

Modifications to the existing GlueX target will be required to stay in compliance with the lab's pressure vessel safety standards. They do not look overwhelming (yet).

Liquid deuterium is also an (easy) option, although rapid switching between LH2 & LD2 might increase the design modifications substantially.

The modified target shown today will require a 1 – 2 year effort from the Target Group and will require a 3 – 6 month access to the GlueX target.