

SIEMENS



[siemens.com/avanto-fit](https://www.siemens.com/avanto-fit)

MAGNETOM Avanto^{fit}

A Tim+Dot System

Data sheet based on *syngo* MR E11

Your standards of care integrated with DotGO

- Stay on time with less exam-time variation
- Make advanced applications such as cardiac exams part of your routine
- Easily manage your protocols with Dot Cockpit

Deliver exceptional image quality and speed with Tim 4G

- Up to 48 RF channels and up to 204 coil elements
- Reduce your scan time while maintaining your image quality
- High homogeneity on full 50 cm FoV and superb fat saturation
- Eased exam workflow with up to 205 cm scan range

Grow your MRI services with Body MRI

- Free-breathing, contrast-enhanced body imaging
- Always the right contrast in dynamic liver evaluation
- Non-invasive liver evaluation

Up to 97% reduction in sound pressure*

- **60 cm** Bore design with large flared opening
- Up to **97%** reduction in sound pressure* with Quiet Suite
- Complete, quiet neurological and orthopedic examinations
- More patient acceptance, fewer rescans
- No impact on image quality

Minimized lifecycle costs

- Fast and easy installation
- Upgrade in only up to 15 working days
- No need to tear walls down for the upgrade



* Data on file

MAGNETOM Avanto^{fit}



Magnet System

General	
Superconducting Magnet	Patient-friendly bore design with large flared opening Large DSV (diameter spherical volume), high homogeneity Easy siting due to AS (Active Shielding) and E.I.S. (External Interference Shielding) magnet technology
Magnet Parameters	
Magnet length	150 cm
Magnet bore diameter ¹⁾	90 cm
Inner tunnel length	88 cm
Length of flared opening	54.5 cm
Inner diameter ²⁾	60 cm
System length	160 cm
Operating field strength	1.5 Tesla
Superconductor	Niobium-Titanium
Field stability over time	<0.1 ppm/h
Number of field-generating coils	7

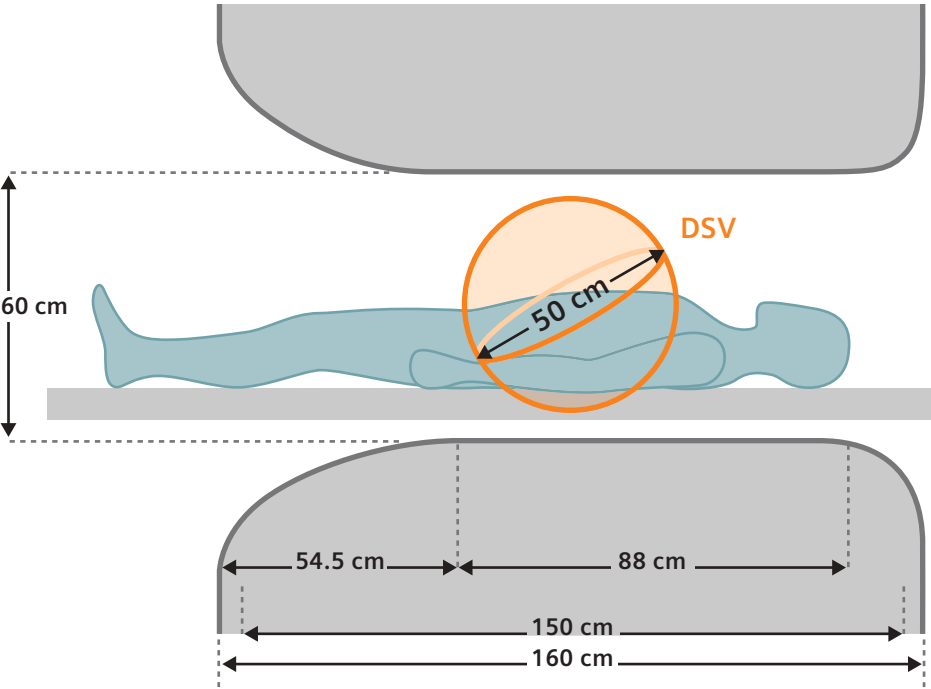

¹⁾ W/o shim coils, gradient coil, RF body coil

²⁾ Incl. shim coils, gradient coil, RF body coil

Homogeneity (based on highly accurate 24 plane plot)		
DSV	Guaranteed	Typical
50 cm	<1.5 ppm	0.8 ppm
45 cm	<1 ppm	0.4 ppm
40 cm	<0.75 ppm	0.2 ppm
30 cm	<0.5 ppm	0.1 ppm
20 cm	<0.25 ppm	0.04 ppm
10 cm	<0.05 ppm	0.01 ppm

DSV = Diameter spherical volume (x, y, and z direction)

Standard deviation V_{rms} (volume root-mean square) measured with highly accurate 24 plane plot method (20 points per plane). Standard active shim with 3 linear channels.

3D Shim

Patient-specific automated shim

For optimization of the magnetic field homogeneity

Time to shim approx. 20 s

Shielding

Active Shielding (AS) 5th generation active shielding (AS) technology with counter coils

Fringe field (axial × radial)	0.5 mT ¹⁾	4.0 m × 2.5 m
	0.1 mT	5.5 m × 3.1 m

External Interference Shield (E.I.S.) Patented shielding system integrated into the magnet
Continuous compensation and automatic suppression of external magnetic field interferences during measurement (caused by moving ferromagnetic objects)

Magnet Cooling System

The MAGNETOM Avanto^{fit} magnet incorporates Zero Helium boil-off technology

Refill interval (typical) Not applicable²⁾

Boil-off rate (typical) 0.0 l/year²⁾

Helium capacity approx. 1600 liters

¹⁾ Pacemaker safety limit

²⁾ For typical clinical use, depending on sequences and operating time with running helium compressor. The system needs to be serviced at regular interval. Undisturbed magnet cooling for 24 hours and 7 days a week.

Gradient System

SQ Gradients: General		
Gradient duty cycle	100%	
Gradient performance for each axis	Max. amplitude	45 mT/m
	Min. rise time	200 μ s from 0 to 40 mT/m
	Max. slew rate	200 T/m/s
Vector gradient performance (vector summation of all 3 gradient axes)	Max. eff. amplitude	72 mT/m
	Max. eff. slew rate	346 T/m/s
Gradient Amplifier		
Water-cooled, highly compact, modular design		
Ultra-fast solid-state technology with very low switching losses		
Max. output voltage ¹⁾	2000 V	
Max. output current ¹⁾	625 A	
Resolution Parameters		
FoV	Min. 5 mm	
	Max. 500 mm	
Slice thickness 2D	Min. 0.1 mm	
	Max. 200 mm	
Partition thickness 3D	Min. 0.05 mm	
	Max. 20 mm	
Slab thickness 3D	Min. 5 mm	
	Max. 500 mm	
Max. matrix	1024	
Highest in-plane resolution	8 μ m	

¹⁾ Values for each of the 3 gradient axes

Sequences		Matrix		
		64	128	256
Spin Echo	min. TR [ms]	4.7	4.8	5.2
	min. TE [ms]	1.5	1.6	1.8
Inversion Recovery	min. TR [ms]	26	26	27
	min. TE [ms]	1.5	1.6	1.8
	min. TI [ms]	21	21	21
2D GRE (TurboFLASH)	min. TR [ms]	0.55	0.68	0.91
	min. TE [ms]	0.22	0.22	0.22
3D GRE (ceMRA)	min. TR [ms]	0.55	0.68	0.91
	min. TE [ms]	0.22	0.22	0.22
TrueFISP	min. TR [ms]	1.66	1.81	2.25
	min. TE [ms]	0.76	0.77	0.97
TSE (HASTE)	min. Echo Spacing [ms]	1.54	1.58	1.84
	min. TR [ms]	4.7	4.8	5.2
	min. TE [ms]	1.5	1.6	1.8
	max. Turbo Factor = 512			
Turbo GSE	min. Echo Spacing [ms]	0.7	0.84	0.94
	min. TR [ms]	5.6	6.2	6.4
	min. TE [ms]	3	3.5	3.5
	max. Turbo Factor = 65			
	max. EPI Factor = 21			
EPI (single-shot and multi-shot)	min. Echo Spacing [ms]	0.29	0.4	0.69
	min. TR [ms]	10	10	10
	min. TE [ms]	2	2.2	2.5
	min. Measurement time	12	15	24
	max. EPI Factor = 256			
Diffusion Imaging	Max. b-value = 10 000 s/mm ²			
	Min. TE [ms] with b = 1000 [s/mm ²]	47	48	52

All matrices without interpolation. Combinations of the stated parameters are not always possible; some parameters may require optional application packages.

DirectRF Technology

General

Tim 4G new and unique all digital-in/digital-out design integrates all RF transmit and receive components at the magnet

- Optical RF system improves SNR by reducing electrical noise and increasing signal detection
- Digital-in and digital-out design: optical links between magnet and equipment room to achieve highest RF stability
- Transmit path is integrated in the magnet housing
- Receive path is integrated in the magnet housing
- Dual-Density Signal Transfer enables ultra-high density coil design by integrating key RF components into the local coil
- Receiver with high dynamic range without adjustments

Direct Transmit Technology

Frequency stability (5 min)	$\pm 2 \times 10^{-10}$
Frequency control	32 bits (0.015 Hz)
Phase control	16 bits (0.006 degrees)
Body coil	Integrated whole body no tune transmit/receive coil with 16 rungs Optimized RF efficiency and signal-to-noise ratio (SNR)
Transmitter path	Feedback loop for unmatched RF stabilization
	Transmit amplitude 16 bit control 25 ns resolution
	Gain stability (after first minute) <0.05 dB (1 s) <0.2 dB (5 min)
Transmit amplifier	Extremely compact, water-cooled solid state amplifier, integrated at the magnet as part of DirectRF technology
	Transmit amplifier bandwidth 800 kHz
	Peak power 26.1 kW

RF Receiver Technology

The revolutionary Total imaging matrix optimizes coil positioning and virtually eliminates coil changing times. It also features Dual-Density Signal Transfer in the local receive coils, which enables the high density design. All local coils are no tune coils. Further Tim 4G features are AutoCoilSelect for dynamic, automatic, or interactive selection of the coil elements within the FoV.

Receive path	Number of coil elements	Up to 204
	Number of independent receiver channels	48
	Quadrature demodulation and filtering	Digital
	Receiver bandwidth	500 Hz –1 MHz (for each channel)
	Receiver signal resolution	32 bit
	ADC sampling rate	80 MHz
	Preamplifier noise figure	<0.5 dB
	Dynamic range at coil connector (referred to 1 Hz resolution bandwidth)	164 dB instantaneous at receiver 169 dB with automatic gain control at local coil connector

Coils

Standard Integrated Whole-Body Coil

No tune transmit/receive coil

1.5T Tim Matrix Coils

The Tim coils are designed for high image quality in combination with easy handling. High element coils increase SNR and reduce examination times. DirectConnect and SlideConnect technology reduce patient set up time. Light weight, ergonomically designed coils enable highest patient comfort.

- No coil changing with multi-exam studies saves patient setup time
- All coils are time-saving “no-tune” coils
- Low-noise preamplifiers
- AutoCoilSelect for dynamic, automatic, or interactive selection of the coil elements within the Field of View

Standard Coils

Head/Neck 20 (DirectConnect)	Application area	Head and neck
	Dimensions (L×W×H)	440 mm × 330 mm × 370 mm
	Weight	4.7 kg
Spine 32 (DirectConnect)	Application area	Spine
	Dimensions (L×W×H)	1200 mm × 489 mm × 63 mm
	Weight	9.8 kg
Body 18 (SlideConnect)	Application area	<ul style="list-style-type: none"> • Thorax • Heart • Abdomen • Pelvis • Hip
	Dimensions (L×W×H)	385 mm × 590 mm × 65 mm
	Weight	1.6 kg
Flex Large 4	Application area	Multi purpose
	Dimensions (L×W)	516 mm × 224 mm
	Weight	550 g
Flex Small 4	Application area	Multi purpose
	Dimensions (L×W)	366 mm × 174 mm
	Weight	450 g
Accessories	<ul style="list-style-type: none"> • Flex Coil Interface 1.5T • Tim Coil Interface 1.5T 	

Combination of all coils possible for large Field of View exams.

Patient Handling

General

Tim 4G and Dot help increase patient comfort and improve workflow efficiency.

- Ultra-light weight coils
- Imaging with optimized high element surface coil
- Remote table move
- Feet-first examinations for many applications (e.g. cardiac, liver, upper abdomen, pelvis, colonography, body angio) reduces the level of anxiety experienced by highly claustrophobic patients
- AutoPosition for selected exams
- In-room Dot Display: Patient preparation is smooth with all patient data displayed right at the scanner. Dot gives the user advice during the positioning process – very helpful in the case of ECG, for example
- Scan range of 204 cm¹⁾ allows for whole body examinations with full usage of the surface coils, without the need for patient repositioning
- Set up the patient once, no repositioning, no changing of coils needed

Patient Positioning Aids

Standard set of cushions for comfortable and stable patient positioning together with safety straps.

Additional positioning supports (optional): Set of vacuum cushions (large, medium, small) with vacuum pump

Tim Table

Comfortable patient table solution which fits the needs for patients up to 200 kg supporting full weight capacity in vertical and horizontal movement. Integrated coils for fast patient preparation and enhanced user comfort. Examinations of patients up to 204 cm¹⁾. Integrated infusion stand.

Max. patient weight for vertical and horizontal table movement	200 kg (440 lbs)
--	------------------

Max. scan range	154 cm, opt. 204 cm ¹⁾
-----------------	-----------------------------------

User can adjust the table speed with two pre-defined speed mode buttons or accelerate continuously with the wheel on the Dot Control Centers

Vertical table movement	Range	52–102 cm ²⁾ +13 mm ³⁾
	Speed	60 mm/s one click table up

Horizontal table movement	Max. range	2600 mm
	Max. speed	200 mm/s
	Position accuracy ⁴⁾	±0.5 mm

Continuous table movement during scan capable

¹⁾ Optional with Tim Whole Body Suite

²⁾ Including Heightening Kit, if necessary

³⁾ Depending on the floor conditions

⁴⁾ Accuracy for repositioning from one direction

Dot Control Centers

Two ergonomically designed control units integrated into the front cover on each side of the patient tunnel. Optional 3rd Dot Control Center including a Dot Display is available at the rear-end of the system.

- Continuous table movement or two speed predefined levels
- Automatic transfer from any vertical position to home position
- Automatic transfer to isocenter
- Automatic transfer from any horizontal position to home position
- In bore ventilation (6-step regulation)
- In bore lighting (6-step regulation)
- Headphone volume adjustment (6-step regulation)
- In room loudspeaker adjustment (6-step regulation)
- Laser light localization
- Start scan
- Alarm off

Horizontal table movement, lighting adjustments, and ventilation are also possible from the console

Dot Display

Dot Display with user guidance for fast and efficient exam preparation and start of measurement at the scanner. Display of physiological curves and guidance for patient set up of triggering device.

Color LCD Monitor	13.3"; 16 : 10
Horizontal frequency	15.0–80.0 kHz
Vertical frequency	50.0–85.1 kHz
Screen Matrix	1280×800 pixels

Physiological Measurement Unit (PMU) – Wireless Physio Control

Synchronizes the measurement with the physiological cycles (triggering to minimize motion artifacts caused by cardiac and respiratory movements). The physiological curves are visualized at the Dot Display.

Wireless Sensors	Wireless Vector ECG/respiration and pulse sensors for physiologically synchronized imaging, rechargeable battery-powered – for optimized patient handling
Physiological Signals	<ul style="list-style-type: none">• ECG (3 channels)• Pulse• Respiration
	ECG Triggering: <ul style="list-style-type: none">• Acquisition of multiple slices, e.g. of the heart, at different phases of the cardiac cycle• Excellent image quality by synchronizing data acquisition with cardiac motion
	Peripheral Pulse Triggering: <ul style="list-style-type: none">• Reduces flow artifacts caused by pulsatile blood flow• Excellent image quality by synchronizing data acquisition to the pulsatile blood flow
	Respiratory Triggering: <ul style="list-style-type: none">• Excellent image quality by synchronizing data acquisition with the respiratory motion
	External Triggering : <ul style="list-style-type: none">• Interface for trigger input from external sources (e.g. Patient Monitoring System) inside the examination room• Interface for trigger input from external sources (e.g. pulse generator, trigger sources for fMRI) outside the examination room• Optical trigger output for fMRI
	Retrospective gating for ECG, peripheral pulse, and external trigger input

Patient Communication

Ergonomically designed patient communication unit – may be placed at any convenient location on the workplace table.

- Intercom system incorporating active noise cancellation for improved patient communication
 - Assistance call via squeeze-bulb for the patient
 - Response to the patient's activation of the squeeze-bulb via communication unit
 - Table stop
 - Sequence stop
 - Volume of speaker in control room
 - Volume of speaker and headphones in examination room for voice commands
 - Connection to external audio system
 - Independent volume control of voice and music
 - Pneumatic system of ergonomically designed headphones
 - Loudspeaker
 - Microphone
 - Automatic and freely programmable voice commands for breath-hold examinations
-

Noise Reduction Features

General Features

The integrated design of MAGNETOM Avanto^{fit} as well as the hardware and software measures included reduce the acoustic noise to a minimum without compromising gradient performance. AudioComfort incorporates aspects of the gradient coil, body coil and magnet as well as the sequence design.

Gradient

- Special epoxy resin and casting technology for damping vibrations
- Reduction of gradient stray field to decrease eddy currents
- Noise-optimization of the MR system with an acoustically soft but mechanically rigid mounting of the gradient coil inside the magnet
- This reduces vibration amplitudes without the drawbacks of supporting the gradient coil directly on the floor

Body Coil

- The supporting tube of the body coil is built from epoxy instead of filament winding for higher stiffness, increasing internal damping and minimizing vibration amplitudes
- In order to achieve maximum noise reduction, the body coil tube was extended beyond the gradient coil. This is an extremely efficient method for reducing noise, since most of the noise is generated at the ends of the gradient coil
- Eddy current circuit boards are permanently attached to the supporting tube to reduce high frequency noise
- The special suspension of the Body coil acts acoustically decoupling

Magnet

- Encapsulation of the entire magnet
- Efficient floor decoupling for reduction of noise transferred to the building
- Noise-optimized cold head

Sequence Design

- Optimized sequence timing
- Sequences automatically avoid parameter settings that cause the gradient coil to resonate
- No relevant application drawbacks – no increase in sequence parameters, i.e. full performance

“Whisper Mode”

The “Whisper Mode” is a user selectable mode that reduces the max. slew rate and max. amplitude of the gradients. It is compatible with nearly all sequence techniques.

Clinical Benefits

- High performance combined with quietness. All gradient demanding protocols using e.g. EPI techniques such as diffusion, perfusion or fMRI examinations show a significant acoustic noise reduction, thanks to Siemens-unique AudioComfort
- AudioComfort makes MR examinations a comfortable experience even for children¹⁾
- AudioComfort avoids the necessity of implementing noise-absorbing measures to achieve a comfortable noise level for technologists and neighbors

Quiet Suite

A family of sequences for extremely quiet neuro and orthopedic imaging, with up to 97% reduction in sound pressure²⁾:

- QuietX TSE, SE and GRE sequences for T1, T2, DarkFluid, SWI and DWI³⁾ contrasts
- PETRA, a 3D T1-weighted UTE sequence.

Quiet Suite sequences employ optimized gradient waveforms to achieve highly significant noise reductions and smoother, more pleasant sounds with no decrements in image quality or substantial increases in scan times. Optimized protocols for the brain, spine and large joints are provided.

¹⁾ MR scanning has not been established as safe for imaging fetuses and infants under two years of age. The responsible physician must evaluate the benefit of the MRI examination in comparison to other imaging procedures.

²⁾ Data on file

³⁾ Prerequisite: Advanced Diffusion package (optional)

Acquisition Parameters

Acquisition Parameters ¹⁾		
2D Slices	Number of slices	
	per single slice stack	1 – 128 (steps of 1)
	per series (total number of slices in one dynamic measurement)	up to 262 144 (depending on matrix size)
	Slice order	Ascending, descending or interleaved
3D Slabs/Partitions	Number of 3D partitions per single slab	4–512
	Number of 3D Slabs (3D volumes)	1–128 (steps of 1)
Acquisition Matrix	Frequency encoding (true imaging matrix without interpolation or oversampling)	64–1024 (in steps of 64)
	Phase encoding	32–1024 (in steps of 1)
Partial Fourier Imaging	Phase partial Fourier (Half Fourier)	4/8–1 (steps of 1/8)
	Read partial Fourier (asymmetric echo)	Selectable
	Slice partial Fourier (3D volumes)	6/8–1 (steps of 1/8)
Rectangular Field-of-View	In phase encoding direction	3–100%
Averaging	Number of data acquisitions	1–32 (steps of 1)
	Averaging mode	Short term, Long term (LOTA)
Oversampling	Read oversampling	100% standard
	Phase oversampling	0–100% (steps of 12.5%)
	Slice oversampling (3D volumes)	0–100% (steps of 12.5%)

¹⁾ Combinations of the parameters stated are not always possible; some parameters may depend on optional application packages

Acquisition Parameters (Continued)			
Interpolation	In plane interpolation in frequencyencoding and phase-encoding direction	Selectable (factor of 2)	
	3D interpolation (3D volumes)	Selectable (up to factor of 2)	
Slice Orientation	Slice orientation for 2D and 3D scans	Transverse, sagittal, coronal, oblique, double oblique (steps of 0.1°)	
	Multi-slice multi-angle (simultaneously)	Yes	
Off-center Shift	Longitudinal direction (head-feet)	-250 mm to +250 mm	
	Horizontal direction (left-right)	-250 mm to +250 mm	
	Vertical direction (anterior-posterior)	-250 mm to +250 mm	
Serial Acquisitions	Number of repeated scans	with constant delay times	1-4096
		with different delay times	1-65
Swap	Exchange of read-out and phase-encoding direction	Yes	

Standard Acquisition and Reconstruction Techniques

Standard techniques

- True Inversion Recovery to obtain strong T1-weighted contrast
- Dark Blood inversion recovery technique that nulls fluid blood signal
- Saturation Recovery for 2D TurboFLASH, gradient echo, and T1-weighted 3D TurboFLASH with short scan time (e.g. MPRAGE)
- Freely adjustable receiver bandwidth, permitting studies with increased signal-to-noise ratio
- Freely adjustable flip angle. Optimized RF pulses for image contrast enhancement and increased signal-to-noise ratio
- MTC (Magnetization Transfer Contrast). Off-resonance RF pulses to suppress signal from certain tissues, thus enhancing the contrast. Used e.g. in MRA
- Argus viewer for reviewing cine studies
- Report Viewer for DICOM structured reports including report editing
- Dynamic Analysis for addition, subtraction, division, standard deviation, calculations of ADC maps, T1 and T2 values, TTP, t-Test, etc.
- Image Filter
- 3D post-processing MPR, MIP, MinIP, SSD
- Flexible film formats and paper print
- Data storage of images and cine AVI files on CD/DVD with DICOM viewer as the viewing tool
- Selectable centric elliptical phase reordering via the user interface
- Inversion Recovery to nullify the signal of fat, fluid or any other tissue
- Multiple Direction Diffusion Weighting (MDDW) – diffusion tensor imaging measurements can be done with multiple diffusion-weightings and up to 12 directions for generating data sets for diffusion tensor imaging.

Sequences

- | | |
|-------------------------------|--|
| Spin Echo family of sequences | <ul style="list-style-type: none">• Spin Echo (SE) – Single, Double, and Multi Echo (up to 32 echoes); Inversion Recovery (IR)• 2D/3D Turbo Spin Echo (TSE) – Restore technique for shorter TR times while maintaining excellent T2 contrast; TurboIR: Inversion Recovery for STIR, DarkFluid T1 and T2, TruelR; Echo Sharing for dual-contrast TSE• 2D TSE with multiple average – it is possible to acquire T2-weighted TSE images during shallow breathing, in a time efficient manner• 2D/3D HASTE (Half-Fourier Acquisition with Single Shot Turbo Spin Echo) – Inversion Recovery for STIR and DarkFluid contrast• SPACE for 3D imaging with high isotropic resolution with T1, T2, PD, and DarkFluid contrast |
|-------------------------------|--|

Sequences (Continued)

- Gradient Echo family of sequences
- 2D/3D FLASH (spoiled GRE) – dual echo for in-/opposed phase imaging 3D VIBE (Volume Interpolated Breathhold Examination) – quick fat saturation; double echo for in-phase/opposed phase 3D imaging; DynaVIBE: Inline 3D elastic motion correction for multi phase data sets of the abdomen; Inline Breast Evaluation
 - 2D/3D MEDIC (Multi Echo Data Image Combination) for high resolution T2 weighted orthopedic imaging and excellent contrast
 - 2D/3D TurboFLASH – 3D MPRAGE; single shot T1 weighted imaging e.g. for abdominal imaging during free breathing
 - 3D GRE for field mapping
 - 2D/3D FISP (Fast Imaging with Steady State Precession)
 - 2D/3D PSIF – PSIF Diffusion
 - Echo Planar Imaging (EPI) – diffusion-weighted; single shot SE and FID e.g. for BOLD imaging and Perfusion-weighted imaging; 2D/3D Segmented EPI (SE and FID)
 - ce-MRA sequence with Inline subtraction and Inline MIP
 - 2D/3D Time-of-Flight (ToF) Angiography – single slab and multi slab; triggered and segmented
 - 2D/3D Phase Contrast Angiography
 - BEAT Tool – TrueFISP segmented; 2D FLASH segmented; Magnetization-prepared TrueFISP (IR, SR, FS); IR TI scout; Retrogating

Standard Fat/Water Imaging

- Fat and Water Saturation. Additional frequency selective RF pulses used to suppress bright signal from fatty tissue. Two selectable modes: weak, strong
- Quick FatSat
- SPAIR: robust fat suppression for body imaging using a frequency selective inversion pulse
- Fat/Water Excitation. Spectral selective RF pulses for exclusive fat/water excitation
- Dixon technique for fat and water separation – available on VIBE and Turbo Spin Echo sequences

Standard Flow Artifact Reduction

- LOTA (Long Term Data Averaging) technique to reduce motion and flow artifact
- Pre-saturation technique. RF saturation pulses to suppress flow and motion artifacts
- Tracking SAT bands maintain constant saturation of venous and/or arterial blood flow, e.g. for 2D/3D sequential MRA
- TONE (Tilted Optimized Non-saturating Excitation). Variable excitation flip angle to compensate inflow saturation effects in 3D MRA. TONE pulse selectable depending on the desired flow direction and speed
- GMR (Gradient Motion Rephasing). Sequences with additional bipolar gradient pulses, permitting effective reduction of flow artifacts

Standard Scan Time Reduction

Elliptical scanning reduces scan time for 3D imaging

iPAT – integrated Parallel Acquisition Technique
high-performance and flexible Parallel Imaging with integrated AutoCalibration

Two algorithms – mSENSE and GRAPPA – for maximum quality for all applications

iPAT is compatible with all relevant sequence techniques (e.g. SE, TSE, SPACE, MEDIC, TIRM DarkFluid, HASTE, EPI, MPRAGE, 3D VIBE, FLASH, TrueFISP, TurboFLASH, FLASH Phase Contrast, etc)

iPAT is compatible with all multi-element coils, as well as coil combinations

Tim Assistant facilitates optimized iPAT settings. Higher speed and temporal resolution can be used for:

- Improved image resolution
- Improved image quality due to reduced artifacts

T-PAT with mSENSE and GRAPPA for advanced parallel imaging provides fast high-resolution dynamic imaging

3 different calibration techniques can be used:

- AutoCalibration with an integrated reference (calibration) scan to additionally save on total scan time
- TurboCalibration uses a separate measurement directly before the actual measurement. Images measured using TurboCalibration are characterized by reduced PAT artifacts.
- T-PAT and PAT averaging for motion artifact suppression using Self-Calibration

iPAT²

More slices and coverage in the same breath-hold by applying PAT in 2 directions simultaneously (phase-encoding direction and 3D direction for 3D sequences)

The effective PAT factor can be maximized, and PAT applications are extended. Typical clinical applications are MR Angiography or ultrafast isotropic T1-weighted 3D imaging of the head

A new iPAT² sequence technique named CAIPIRINHA (Controlled Aliasing In Parallel Imaging Results IN Higher Acceleration) has been added. It can be applied to volumetric 3D imaging e.g. in the abdominal region.

Standard Motion Correction

BLADE	<ul style="list-style-type: none"> • Improves image quality by minimizing and correcting for the effects of motion during an MR sequence acquisition. e.g. head, spine, orthopedic imaging and the abdomen • Motion insensitive Turbo Spin Echo sequence • Can be used with all coils and in all planes • Supports T2-weighted, T1-weighted, STIR, and DarkFluid protocols • Simultaneous in-plane motion correction for arbitrary slice orientations • Versatile sequence e.g. supporting iPAT with GRAPPA, Restore pulses and supports respiratory triggered imaging of the abdomen using 2D PACE
1D PACE (Prospective Acquisition CorrEction)	Quick and easy acquisition control for free breathing examinations, e.g. for cardiac imaging
2D PACE Precise Motion Correction	<ul style="list-style-type: none"> • Detects and corrects respiratory motion of the heart, liver, etc. for free breathing high resolution 2D and 3D examinations • Significantly increased image quality • Improved security in the diagnosis of diseases in moving organs and precise slice registration for multi breath-hold studies • Eliminates the need for respiratory belt • PAT averaging for motion artifact suppression using Self-Calibration

Standard Workflow Enhancements

AutoCoilDetect	Detects the position and orientation of coils automatically. Shows coils in the user interface right within the graphical slice positioning.
AutoCoilSelect	Automatic detection and selection of all coil elements in the active Field-of-View.
<i>syngo</i> © Scan Assistant	Shows parameter constraints and provides possible solutions.
scan@center	Automated movement of table so that the scan is performed in the magnet isocenter – can be activated or deactivated by the user.
AutoVoiceCommands	These multi-language automatic voice commands during the scanning to help synchronize timing of breathing, scanning, and contrast media injection.
Phoenix and PhoenixZIP	Exchange of protocol data (e.g. via Internet) by drag & drop clinical images. PhoenixZIP allows transfer of whole measurement programs.

Standard Workflow Enhancements (Continued)¹⁾

Online Help Functions	Context sensitive and quick resource for questions about software operation or MR physics.
DirectConnect	Cable-less direct connection for Head/Neck 20, Spine 32, Foot/Ankle 16.
SlideConnect	SlideConnect cable connectors can be securely plugged-in with one hand only.
Inline Technology – Processing Instead of Post-processing	<p>Inline Technology helps to streamline the clinical workflow by automating mundane post-processing steps before image viewing. See the clinical results immediately. Inline functionality is user-configurable. Examples:</p> <ul style="list-style-type: none">• Automatic subtraction of images, e.g. pre- and post-contrast enhancements• MIP on-the-fly, e.g. MR Angiography with automatic image subtraction and following MIP in three orthogonal planes• Prospective motion correction (1D and 2D PACE) on-the-fly• Automatic perfusion¹⁾ and diffusion maps• Automatic composing of multi-step images¹⁾• Automatic on-the-fly calculation of standard deviation, for better differentiation of arterial and venous phases• Inline Display automatically shows reconstructed images. It offers immediate access to the results and opens automatically for e.g. interactive real-time scanning or CareBolus examinations• Inline Movie automatically starts the cine image display

TimCT FastView

TimCT FastView is the “one go” localizer for the whole body or large body regions such as the whole spine or the whole abdomen. It acquires the complete extended Field of View in one volume with isotropic resolution. Transverse, coronal and sagittal reformats of the volume are calculated Inline and displayed for planning subsequent exams.

- Inline reconstruction of the localizer images during the scan
- Localizing images in the three planes over the maximum Field of View available for subsequent planning in all orientations.
- TimCT FastView runs without laser light positioning to further streamline the workflow for several indications

¹⁾ Optional

Tim Application Suite

The Tim Application Suite offers a complete range of clinically optimized examinations for all regions. The Tim Application Suite – allowing excellent head-to-toe imaging – is provided standard on MAGNETOM Avanto^{fit}.

- Neuro Suite
- Angio Suite
- Cardiac Suite
- Body Suite
- Onco Suite
- Ortho Suite
- Breast Suite
- Scientific Suite
- Pediatric Suite¹⁾

Neuro Suite

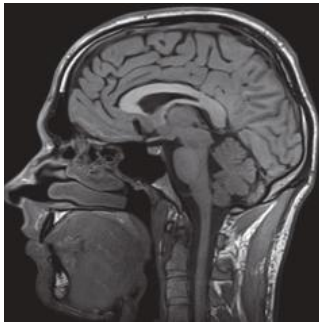

Comprehensive head and spine examinations can be performed with dedicated programs. High resolution protocols and fast protocols for uncooperative patients are provided. The Neuro Suite also includes protocols for diffusion imaging, perfusion imaging, and fMRI.

¹⁾ MR scanning has not been established as safe for imaging fetuses and infants under two years of age. The responsible physician must evaluate the benefit of the MRI examination in comparison to other imaging procedures.

Neuro Suite (Continued)¹⁾

General features

- Fast 2D imaging with SE, TSE, GRE protocols for high-resolution imaging in all orientations and all contrasts
- BLADE motion correction for TSE imaging in all orientations and contrasts
- EPI sequences and protocols for diffusion imaging, perfusion imaging, and fMRI for advanced neuro applications. Diffusion-weighted imaging is possible with up to 16 b-values in the orthogonal directions
- 3D TOF for non-contrast-enhanced angiography
- 3D isotropic resolution volume imaging using T1 3D MPRAGE / 3D FLASH, SPACE DarkFluid, T1 SPACE, T2 SPACE, and 3D TSE T2-weighted high resolution 3D Restore protocols optimized for inner ear examinations
- Double Inversion Recovery 3D protocols (DIR SPACE) with two userselectable inversion pulses for the simultaneous suppression of e.g. cerebrospinal fluid and white matter
- MP2RAGE (Magnetization Prepared 2 Rapid Acquisition Gradient Echoes) provides homogeneous tissue contrast for segmentation and applications such as voxel-based morphometry. In combination with MapIt¹⁾, it also provides T1 mapping functionality.
- Whole-spine protocols in multiple steps with software controlled table movement
- 2D and 3D MEDIC protocols for T2-weighted imaging, particularly for C-spine examinations in axial orientation where reproducibility is difficult due to CSF pulsations and blood flow artifacts
- 3D Myelo with 3D HASTE and 3D True-FISP for anatomical details
- Dynamic sacro-iliac joint imaging after contrast administration using a fast T1-weighted FLASH 2D sequence
- Spine diffusion protocols to differentiate osteoporosis versus tumor infiltration and post-radiotherapy changes versus residual tumor with PSIF sequence
- Precision filter for high spatial accuracy e.g. for neuro intra-operative imaging and stereotactic planning
- 3D CISS (Constructive Interference in Steady State) for excellent visualization of fine structures such as cranial nerves. High resolution imaging of inner ear and spine
- TGSE sequence used primarily for T2-weighted imaging for shorter measurement time, decreased RF power deposition, improved visualization of hemorrhage, and high resolution imaging of brain and spine
- AutoAlign Head LS providing a fast, easy, standardized, and reproducible patient scanning supporting reading by delivering a higher and more standardized image quality

¹⁾ Option

Angio Suite

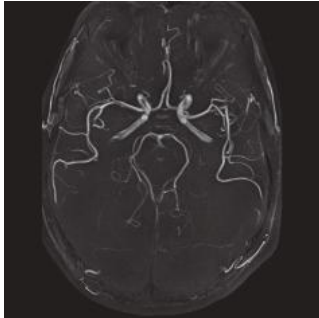

Excellent MR Angiography can be performed to visualize arteries and veins with or without contrast agent.

Contrast-enhanced MRA

- 3D contrast-enhanced MRA protocols for e.g. single step, dynamic, peripheral, whole body MRA with the shortest TR and TE. The strong gradients make it possible to separate the arterial phase from the venous phase.
- TestBolus workflow for optimal bolus timing and excellent image quality
- CareBolus functionality for accurate determination of the bolus arrival time and the "Stop and Continue" of the 3D ce-MRA protocol after the 2D bolus control scan
- Dynamic ce-MRA for 3D imaging over time

Non-contrast MRA and venography

- 2D or 3D Time-of-Flight (ToF) protocols for MRA for the Circle of Willis, carotids, neck vessels, and breath-hold protocols for abdominal vessels
- Triggered 2D ToF sequences for non-contrast MRA, particularly in the abdomen and the extremities
- 2D/3D Phase-Contrast
- MR venography with 2D/3D Time-of-Flight (ToF) and Phase-Contrast
- TONE (Tilted optimized non-saturating excitation) and MTC (Magnetization Transfer Contrast) techniques for improved Contrast-to-Noise Ratio (CNR)

Image processing tools

- MPR, MIP, MinIP, and 3D SSD
- Inline MIP for immediate results
- Inline subtraction of pre- and post-contrast measurements
- Inline standard deviation maps of Phase-Contrast measurements for delineation of arteries and veins

Cardiac Suite

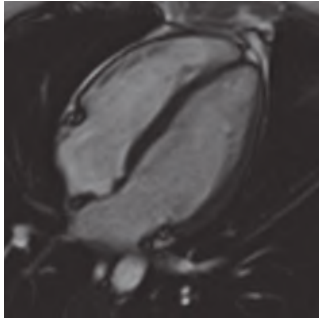

The cardiac suite covers comprehensive 2D routine cardiac applications, ranging from morphology and ventricular function to tissue characterization. Featuring BEAT 2D in conjunction with iPAT and T-PAT techniques

Cardiac views

- Fast acquisition of the basic cardiac orientations for further examination planning
- Cardiac scouting provides users with a step-by-step procedure for the visualization and planning of typical cardiac views, e.g. based on TrueFISP or Dark Blood TurboFLASH: short-axis, 4-chamber, and 2-chamber views.

BEAT

- Unique tool for fast and easy cardiovascular MR imaging
- E.g. 1 click change from FLASH to TrueFISP for easy contrast optimization
- 1-click to switch arrhythmia rejection on/off
- 1-click change from Cartesian to radial sampling to increase effective image resolution (e.g. in pediatric patients)¹⁾ and avoid folding artifacts in large patients

Visualization of structural cardiovascular pathologies with CMR – BEAT

- Breath-hold and free breathing techniques for strong contrast between the blood and vascular structures. Dark Blood TSE and HASTE imaging are available for the structural evaluation of the cardiothoracic anatomy, including vessels or heart valves. Cine techniques (FLASH & TrueFISP) for high-resolution valve evaluation
- Multiple contrasts such as T1- and T2-weighted imaging for use in diseases such as myocarditis (inflammation/hyperaemia), ARVD (fibrous-fatty degeneration) or acute myocardial infarction (edema)
- Dark-blood TSE with motion compensation for high-quality vessel wall imaging in small or large vessels

¹⁾ MR scanning has not been established as safe for imaging fetuses and infants under two years of age. The responsible physician must evaluate the benefit of the MRI examination in comparison to other imaging procedures.

Cardiac Suite (Continued)

Tools for rapid evaluation of left or right ventricular function:

- Acquisition of a stack of short-axis slices (standard segmented FLASH, or advanced segmented TrueFISP)
- Automatic adjustment of the acquisition window to the current heart rate
- Use of the Inline ECG for graphical ECG triggering setup
- Retrospective gating with cine sequences (TrueFISP, FLASH)
- Protocols for whole-heart coverage
- iPAT integration for highest temporal and spatial resolution
- Real-time imaging in case the patient is not able to hold his breath

Dynamic imaging and tissue characterization with BEAT Protocols for high-contrast and high-resolution tissue characterization

- Protocols for stress and rest imaging with TrueFISP or TurboFLASH contrast support the acquisition of multiple slices with high resolution and arbitrarily adjustable slice orientation for each slice
- T-PAT with mSENSE and GRAPPA for advanced parallel imaging provides fast high-resolution dynamic imaging
- Segmented IR TrueFISP/FLASH with TI scout for optimization of tissue contrast
- Advanced tissue characterization with 2D phase-sensitive IR (PSIR) sequences TrueFISP and FLASH contrast. Magnitude and phase-sensitive images with one acquisition
- Simple: no adjustment of inversion time (TI) necessary with PSIR technique
- Ungated single-shot PSIR imaging for tissue characterization under difficult conditions: free-breathing technique that can be applied even in case of arrhythmia

Body Suite

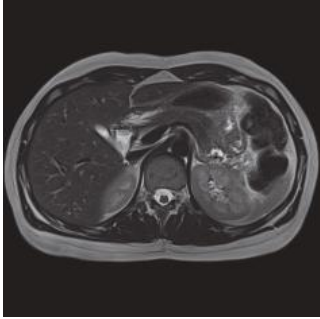

The Body Suite is dedicated to clinical body applications. Ultra-fast high resolution 2D and 3D protocols are provided for abdomen, pelvis, MR Colonography, MRCP, dynamic kidney, and MR Urography applications. 2D PACE technique makes body imaging easy, allowing multi-breathhold examinations as well as free breathing during the scans. Motion artifacts are greatly reduced with 2D PACE Inline technology.

This package includes:

- Free breathing 2D PACE applications with 2D/3D HASTE (RESTORE) and 2D/3D TSE (RESTORE)
- It is possible to use a phase navigator, which measures respiratory induced off-resonance effects. The positioning can be done automatically for most protocols.
- Optimized fast single shot HASTE protocols and high-resolution 3D RESTORE protocols based on SPACE and TSE for MRCP and MR Urography examinations
- REVEAL: diffusion imaging for abdomen and whole body exams. In protocols with multiple b-values individual numbers of averages may be specified per b-value.

Body Suite (Continued)

Abdomen

2D:

- T1 (FLASH) breath-hold scans with and without FatSat (SPAIR, Quick FatSat, in-/opp-phase)
- T2 (HASTE, TSE/BLADE, EPI) breath-hold scans with and without FatSat (SPAIR, FatSat, STIR)
- 2D TSE with multiple average- it is possible to acquire T2-weighted TSE images during shallow breathing, in a time efficient manner
- T1 (TFL) triggered scans (2D PACE free breathing) in-/opp-phase
- T2 (HASTE, TSE/BLADE, EPI) triggered scans (2D PACE free breathing) with and without FatSat (SPAIR, FatSat, STIR) as well as HASTE- and TSE-multi-echo
- Optimized fast single shot HASTE protocols and high-resolution 3D RESTORE protocols based on SPACE and TSE for MRCP and MR urography examinations

3D:

- Dixon (VIBE 2pt-Dixon) breath-hold scans; the following contrasts can be obtained: in-phase, opposed phase, fat and water image
- Dynamic (VIBE and Quick-FatSat) protocols with Inline motion correction for visualization of focal lesions with high spatial and temporal resolution
- Colonography bright lumen with T2 TrueFISP and dark lumen with T1-weighted VIBE
- CAIPIRINHA (Controlled Aliasing In Parallel Imaging Results IN Higher Acceleration) – reduces breath-hold times for 3D VIBE FS and 3D DIXON (in, opposed, water, fat)

Pelvis

- High-resolution T1, T2 pelvic imaging (prostate, cervix)
- Isotropic T2 SPACE 3D protocols for tumor search in the pelvis
- Dynamic volume examinations with 3D VIBE
- REVEAL: Diffusion-weighted imaging of the prostate, cervix, rectum and other organs with multiple b-values. Inline calculation (interpolation) of high b-values (up to $b=1600 \text{ s/mm}^2$)

Onco Suite

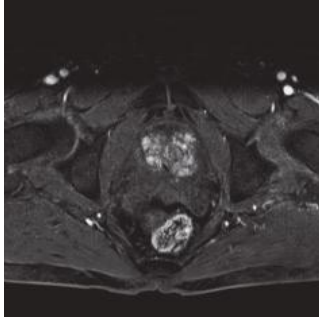

MR imaging provides excellent soft tissue contrast, multi-planar capabilities and the possibility of selectively suppressing specific tissue, e.g. fat or water. The Onco Suite features a collection of sequences as well as protocols and evaluation tools that may be used for a detailed assessment of a variety of oncological conditions.

General features

- STIR TSE, HASTE, and FLASH in-phase and opposed-phase protocols for highly sensitive visualization of metastases
- Dynamic imaging protocols for assessment of the kinetic behavior for lesion visualization and characterization
- Quantitative evaluation and fast analysis of the data with colorized Wash-in, Wash-out, Time-To-Peak, Positive-Enhancement-Integral, MIPtime and combination maps with Inline technology or for offline calculation
- Display and analysis of the temporal behavior in selected regions of interest with the included Mean Curve postprocessing application. This includes the capability of using additional datasets as a guide for defining regions of interest even faster and easier than before.
- REVEAL: diffusion imaging for liver and whole body exams. In protocols with multiple b-values individual numbers of averages may be specified for each b-value.

Prostate protocols

- Dedicated prostate protocols, which may help in the detection, localization, and staging of tumors and recurrences
- REVEAL: Diffusion-weighted imaging of the prostate with multiple b-values. Inline calculation (interpolation) of high b-values (up to $b=1600 \text{ s/mm}^2$) possible.
- Protocols with high temporal resolution allow time course evaluation based on pharmacokinetic modeling
- Prostate spectroscopy (3D CSI volume scan) with up to 8 sat bands supports tumor diagnosis¹⁾
- RESOLVE¹⁾: Diffusion-weighted, readout-segmented (multi shot) EPI sequence for high-resolution susceptibility-insensitive DWI of the prostate

¹⁾ Option

Ortho Suite

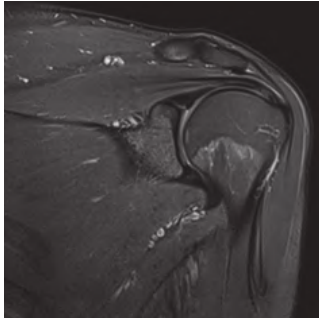

The Ortho Suite is a comprehensive collection of protocols for joint imaging including the spine. Also in case of tumors, infections, or vascular necrosis, a large amount of additional information can be acquired using the protocols provided as standard in this suite.

General features

- 2D TSE protocols for PD, T1, and T2-weighted contrast with high in-plane resolution and thin slices
- 3D MEDIC, 3D TrueFISP protocols with water excitation for T2-weighted imaging with high in-plane resolution and thin slices
- High resolution 3D VIBE protocols for MR Arthrography (knee, shoulder, and hip)
- 3D MEDIC, 3D TrueFISP, 3D VIBE protocols with Water Excitation having high isotropic resolution optimized for 3D post-processing
- T1, T2, and PD SPACE, 3D imaging with high isotropic resolution optimized for post-processing
- Whole-spine, single-step, and multi-step protocols
- Excellent fat suppression in off-center positions, e.g. in the shoulder due to high magnet homogeneity
- Dynamic TMJ protocol (different joint positions)
- Dynamic ilio-sacral joint protocol for contrast dynamics
- Multi Echo SE sequence with up to 32 echoes for T2 time mapping
- High resolution 3D DESS (Double Echo Steady State): T2/T1-weighted imaging for excellent fluid-cartilage differentiation
- 2 point Dixon technique for fat and water separation – Turbo Spin Echo sequence
- WARP – 2D TSE sequence combining optimized high-bandwidth protocols and View Angle Tilting (VAT), tailored to reduce susceptibility artifacts caused by orthopedic MR-Conditional¹⁾ metal implants. This helps in the evaluation of soft tissue in proximity of the implants. Available protocols include T1-weighted, T2-weighted, proton density and STIR contrast.

¹⁾ MR imaging of patients with metallic implants brings specific risks. However, certain implants are approved by the governing regulatory bodies to be MR conditionally safe. For such implants, the previously mentioned warning may not be applicable. Please contact the implant manufacturer for the specific conditional information. The conditions for MR safety are the responsibility of the implant manufacturer, not of Siemens.

Breast Suite



MR imaging provides excellent tissue contrast that may be useful in the evaluation of the breasts. Extremely high spatial and temporal resolution can be achieved in very short measuring times by using iPAT with GRAPPA. Customized protocols (e.g. with fat saturation, or water or silicone excitation), as well as flexible multiplanar visualization allow a fast, simple and reproducible evaluation of MR breast examinations.

General features

This package includes:

- High-resolution 2D protocols for morphology evaluation
- High-resolution 3D protocols covering both breasts simultaneously
- Protocols to support interventions (fine needle and vacuum biopsies, wire localization)
- Protocols for evaluating breasts with silicone implants
- Automatic and manual frequency adjustment, taking into account the silicone signal
- Detection of the silicone signal either to suppress the silicone signal, if the surrounding tissue is to be evaluated, or to suppress the tissue signal in order to detect an implant leakage
- SPAIR – robust fat sat (robust fat suppression using an adiabatic frequency selective inversion pulse)
- DIXON – 2-point Dixon with 3D VIBE; the following contrasts can be obtained: in-phase, opposed phase, fat and water image
- iPAT with GRAPPA for maximum resolution in short time
- iPAT² that allows state-of-the-art sagittal breast imaging
- Inline subtraction and MIP display
- Offline subtraction, MPR and MIP display
- REVEAL: diffusion imaging for breast exams. In protocols with multiple b-values individual numbers of averages may be specified per b-value.
- RESOLVE¹⁾: Diffusion-weighted, readout-segmented (multi shot) EPI sequence for high-resolution susceptibility-insensitive DWI of the prostate

RADIANT

Ultrasound like reconstruction around the nipple

VIEWS (Volume Imaging with Enhanced Water Signal)

- Bilateral – both breasts are examined simultaneously
- Axial – the milk ducts are directly displayed
- Fat-saturated or water-excited – fat complicates clinical evaluation and is suppressed
- Near-isotropic 3D measurement – the same voxel size in all three directions for reconstruction in any slice direction
- Submillimeter voxel – highest resolution for precise evaluation

¹⁾ Optional

Scientific Suite

The Scientific Suite supports scientific users by providing easy access to application-specific data for further processing and advanced image calculus.

- General features
- Support of USB Memory sticks
 - Access to file system via a secure and comfortable File Browser
 - Anonymization of patient data
 - Easy creation of AVIs and screen snapshots to include in presentations or teaching videos
 - Export of tables, statistics and signal time courses to communal exchange formats like e.g. tabulated text files (MeanCurve, Spectroscopy evaluation, DTI evaluation)
 - Advanced image calculus including T2 and T1 time calculation, addition, subtraction, multiplication, division, log, and integration of images

Pediatric Suite¹⁾

Tissue relaxation times in pediatrics are very different compared to those of adults. The reasons for these differences are: developing tissues, body size, faster heart rates, and compliance with breathhold commands. Protocols can be easily adapted for imaging infants.

¹⁾ MR scanning has not been established as safe for imaging fetuses and infants under two years of age. The responsible physician must evaluate the benefit of the MRI examination in comparison to other imaging procedures.

DotGO. Go for consistent results, efficiently

In 2009, Siemens set the benchmark in MR scanning and productivity by introducing Dot. Easily adapt to the patient's condition or clinical question, consistently achieve reproducible, high-quality results, and consequently reduce exam times and the number of rescans. From 2014 on, the newest generation of Dot – DotGO – is also setting the standard in protocol configuration. For true flexibility, consistency and efficiency in every aspect of MRI.

Flexibility. Intuitive protocol management.

One central user-interface to configure any protocol and flexibly create your exam strategies. Intuitive, fast functionality results in 80%¹⁾ improved usability in exam configuration. DotGO empowers you to provide your MRI expertise for the entire department and to define a higher standard of care for more patients and referrers.

Consistency. Quality results for each exam.

Every patient is different. Every referrer's and radiologist's requirement is different. But your results need to be consistent and of high quality. Your daily schedule has to be met. DotGO partners you in meeting all of these different needs with dedicated functionality for the clinical question at hand.

Efficiency. Stay on time with less than 1 minute exam-time variation.²⁾

Time, quality and costs define the efficiency of your MRI exams. DotGO enables scheduling to be more predictable by reducing exam-time variations to less than a minute²⁾. Also time-consuming software interaction is reduced dramatically (by up to 46%³⁾). Standardized procedures support quality results for each exam and help to reduce rescans. All in all turnaround time to the referrer is quicker, quality higher, and MRI more efficient.

¹⁾ Compared to MR protocol configuration without Dot Cockpit, Usability Study, 2013

²⁾ Zhongshang Hospital Fudan University, Fudan, CN, Abdomen Dot Engine Workflow Study

³⁾ University Hospital Essen, GER, Brain Dot Engine Workflow Study

Dot Cockpit

Intuitive protocol management.

by providing unprecedented flexibility in MRI configuration.

At the heart of this new flexibility is the Dot Cockpit. It is the central protocol management platform enabling highly flexible and intuitive configuration, manipulation, organisation and updating of all protocols. Whether you are using a Dot engine or not, the Dot Cockpit is the new starting point for every exam.

MRI flexibility from the start:

- One central user-interface for every protocol
- Fast and intuitive protocol configuration (80%³ better usability in MRI exam configuration)
- User-friendly functionalities like drag & drop, Dynamic Search
- Exam strategies created with one click
- Multiple strategies in one protocol
- Change protocols on the fly
- Update parameter changes to all or a selection of identically configured protocols anywhere in the Dot Cockpit. (Identical Configurations)

Take the lead in defining the standard of MRI in your institution!

Dot Cockpit



Designed to realize the full potential of the Dot engines. The new Dot Cockpit is your central interface for all protocol management tasks. This includes flexible configuration of all Dot engines, according to your standards of care. In the following, we introduce the most important features of the new Dot Cockpit.

Dot Cockpit (Continued)

Configure all protocols from one central interface	The Dot Cockpit enables you to configure and save all of your MRI protocols and Dot engines.
Dot Explorer and Program Editor on one page	The Dot Cockpit offers two tasks: Dot Explorer and Program Editor. In the Dot Explorer, you browse through and organize your protocols. In the Program Editor, you modify them.
A new program overview	With the Dot Cockpit, you can see the whole exam workflow, the different User Trees, Protocols, Strategies, Decisions, Sequences and AddIns are visualised together on one page.
Dynamic search delivers highlighted results	In the Dot Explorer, searching for protocols is very quick. Just type in your search query, and results are highlighted instantly.
Editing protocols instantly	In order to modify a protocol opened in the Dot Explorer, you can immediately switch to the Program Editor with one click.
Adding a new Strategy	In the Program Editor, just drag & drop or click on the Strategy button in the sidebar, and a new Strategy is added to your exam workflow. This step automatically creates a new Dot engine.
Drag & drop from the sidebar	In the Program Editor, you can add protocols to a Strategy by drag & drop from the sidebar.
User-friendly toolbar	Use the toolbar for opening and saving of programs, for Copy, Paste, Undo, Redo – in the same way as you are used to in Office programs.

Brain Dot Engine



The Brain Dot Engine simplifies general brain examinations with guided and automated workflows customized to your standards of care. The Brain Dot Engine supports the user in achieving reproducible image quality with increased ease of use and time efficient exams.

Patient View	Within the Patient View the user can easily tailor examinations to an individual patient. Dot Exam Strategies allow you to choose the most appropriate strategy with one mouse click, the complete scan setup is then automatically prepared.
Guidance View	Step-by-step user guidance is seamlessly integrated. Example images and guidance text are displayed for each individual step of the scanning workflow to ensure perfect scanning even by novice operators. Both images and text are easily configurable by the user.
Parameter View	The new streamlined Parameter View displays a user-defined subset of parameters which are available for manual protocol optimization. If desired, the user can switch to the conventional – fully loaded – parameter view at any time.
AutoPosition	The head of the patient is automatically placed at the isocenter without any laser marking required.
AutoAlign Head LS	Automated, positioning and alignment of slice groups to the anatomy, relying on multiple anatomical landmarks. Provides fast, easy, and reproducible patient scanning and facilitates the reading by consistently delivering high image quality with a standardized slice orientation, both for follow-ups and across patients. Besides basic brain positioning, AutoAlign Head LS computes reference position for several other brain structures such as the inner ear, the orbits and the optic nerve. It also delivers robust and consistent results independently of patient age, head position, disease or existing lesions.
AutoCoverage	Maximizes the speed of the examination by automatically setting the number of slices and the FoV to fully cover the brain. This is performed based on the information delivered by AutoAlign, eliminating manual setting and the scanning of unnecessary slices.

Brain Dot Engine (Continued)

Dot Exam Strategies	<p>Examinations can be easily personalized to the individual patient condition and clinical need. The Brain Dot Engine comes with the following predefined examination strategies, which the user can select according to patient conditions or change at any time during the workflow, when conditions change:</p> <ul style="list-style-type: none">• Standard: Standard examination with 2D protocols• Resolution focus: Examination with 3D protocols (with e.g. SPACE) for detailed views• Speed focus: Examination with fast 2D protocols (with e.g. HASTE) for further speeding up the exam• Motion-insensitive: Examination with BLADE protocols to minimize and correct for the effects of motion automatically
BLADE	<p>Motion insensitive Turbo Spin Echo sequence. Improves image quality by correcting for the effects of motion during an MR acquisition. (Can be used in head, spine, and other body regions).</p>
Rerun	<p>An image inside the examination UI can be selected and a rerun of the corresponding series can be triggered with identical sequences or parameters.</p>
Inline MPRs	<p>Automatic multiplanar reconstruction for 3D datasets. The Multi Planar Reconstruction (MPR) tool can be easily configured to automatically generate any required 2D images from high resolution 3D acquisitions by using the position information from the AutoAlign algorithm.</p>
Inline Diffusion	<p>Automatic calculation of trace-weighted images and ADC maps with Inline Technology.</p>
Customization	<p>The Brain Dot Engine can be easily modified by the user to their individual standard of care.</p> <ul style="list-style-type: none">• Add/remove protocol steps• Change guidance content (images and text)• Change or add Dot exam strategies• Add clinical decision points• Add/remove parameters in the parameter viewing card• User-defined offsets to the standard positions delivered by AutoAlign• Customized inline MPR reconstructions

Large Joint Dot Engine¹⁾



The Large Joint Dot Engine optimizes image quality of knee, hip and shoulder scans by proposing the most appropriate protocols according to the examination strategy chosen for the specific patient. It ensures reproducible image quality and streamlines large joint examinations to the greatest extent. The Large Joint Dot Engine features AutoAlign and AutoCoverage for knee, hip and shoulder. The advanced WARP²⁾ techniques included in the Large Joint Dot Engine provide susceptibility artifact reduction functionality (e.g. from MR conditional metal implants), and include optimized protocols for knee and hip examinations. High resolution 3D imaging programs together with user-configurable automatic inline MPR (Multi Planar Reconstruction) calculations provide increased efficiency, reproducibility and ease of use.

Patient View	Within the Patient View the user can easily tailor examinations to an individual patient. Dot Exam Strategies allow you to choose the most appropriate strategy with one mouse click, the complete scan setup is then automatically prepared.
Guidance View	Step-by-step user guidance is seamlessly integrated. Example images and guidance text are displayed for each individual step of the scanning workflow to ensure perfect scanning even by novice operators. Both images and text are easily configurable by the user.
Parameter View	The new streamlined Parameter View displays a user-defined subset of parameters which are available for manual protocol optimization. If desired, the user can switch to the conventional – fully loaded – parameter view at any time.
Dot Exam Strategies	Examinations can be easily personalized to the individual patient condition and clinical need. The Large Joint Dot Engine comes with the following predefined examination strategies, which the user can select according to patient conditions or change at any time during the workflow, when conditions change: <ul style="list-style-type: none"> • Standard: Achieve highest image quality in a reasonable scan time with 2D and 3D protocols. • Speed focus: Examine patients in the shortest possible time with protocols being accelerated to the maximal extension. • Motion Insensitive (BLADE): Compensate for the effects of motion with motion insensitive BLADE protocols. • High Bandwidth (WARP²⁾): Optimized strategy for the reduction of susceptibility artifacts.

¹⁾ Optional

²⁾ MR imaging of patients with metallic implants brings specific risks. However, certain implants are approved by the governing regulatory bodies to be MR conditionally safe. For such implants, the previously mentioned warning may not be applicable. Please contact the implant manufacturer for the specific conditional information. The conditions for MR safety are the responsibility of the implant manufacturer, not of Siemens.

Large Joint Dot Engine (Continued)

AutoAlign	Automated, positioning and alignment of slice groups to the anatomy, relying on multiple anatomical landmarks. Provides fast, easy, and reproducible patient scanning and facilitates the reading by consistently delivering high image quality with a standardized slice orientation.
AutoCoverage	Maximizes the speed of the examination by automatically setting the number of slices and the FoV to fully cover hip or shoulder. This is performed based on the information delivered by AutoAlign, eliminating manual setting and the scanning of unnecessary slices.
Inline MPRs	Automatic multiplanar reconstruction for 3D datasets. The Multi Planar Reconstruction (MPR) tool can be easily configured to automatically generate any required 2D images from high resolution 3D acquisitions by using the position information from the AutoAlign algorithm.
WARP	Susceptibility Artifact Reduction techniques <ul style="list-style-type: none">• 2D TSE sequences combining high bandwidth protocols and VAT (View Angle Tilting)-technique, tailored to reduce susceptibility artifacts (e.g. from MR conditional metal implants¹⁾). Available protocols include T1-weighted, T2-weighted, proton density and STIR contrast.
Customization	The Large Joint Dot Engine can be easily modified by the user to their individual standard of care. <ul style="list-style-type: none">• Add/remove protocol steps• Change guidance content (images and text)• Change or add Dot exam strategies• Add clinical decision points• Add/remove parameters in the parameter viewing card User-defined offsets to the standard positions delivered by AutoAlign Customized inline MPR reconstructions

¹⁾ MR imaging of patients with metallic implants brings specific risks. However, certain implants are approved by the governing regulatory bodies to be MR conditionally safe. For such implants, the previously mentioned warning may not be applicable. Please contact the implant manufacturer for the specific conditional information. The conditions for MR safety are the responsibility of the implant manufacturer, not of Siemens.

Abdomen Dot Engine¹⁾



The Abdomen Dot Engine offers standardized, efficient, and comprehensive workflows for the upper abdomen with excellent image quality. The workflow covers the liver, biliary and pancreatic system and, if slightly adapted, kidneys as well. The workflow is prepared for easy reading and reporting together with *syngo.via*.

Patient View	<p>Within the Patient View the user can easily tailor the exam to each individual patient. Several pre-defined Dot Exam Strategies can be integrated.</p> <p>The user just selects the appropriate strategy with one click, and the queue and the complete scan set-up are updated automatically. Furthermore protocols tailored for use of contrast media can be integrated.</p>
Guidance View	<p>Step-by-step user guidance is seamlessly integrated. Example images and guidance text are displayed for each individual step of the scanning workflow. Both images and text are easily configurable by the user.</p>
Parameter View	<p>The new streamlined Parameter View displays the parameters that are really needed for the scan set-up. If desired, the user can switch to the conventional – fully loaded – parameter view at any time.</p>
AutoPosition	<p>After registration the patient is positioned automatically at the optimal scanning position.</p>
AutoAlign and AutoCoverage	<p>Automated adaption of scanning parameters according to physiological characteristic (AutoFoV, AutoNavigator, AutoCoverage breath-hold adaptations)</p>
AutoNavigator	<p>Automatic breathing pattern detection and scaling of triggered scans</p>
AutoFoV (automatic Field of View calculation)	<p>Based on the localizer images the optimal FoV is automatically estimated. In case the patient moves during the examination, this step can be repeated at any time.</p>
Abdomen Dot Library	<p>StarVIBE¹⁾ and TWIST-VIBE¹⁾ protocols can be integrated into the Abdomen Dot library.</p>

¹⁾ Optional

Abdomen Dot Engine (Continued)

Dot Exam Strategies	<p>The workflow can be personalized to the individual patient's condition and clinical need. The following predefined strategies are included. They can be changed at any time during the workflow:</p> <ul style="list-style-type: none">• Breathhold (fast with robust image quality)• Respiratory Synchronized (using PACE triggering, high image resolution)• Motion-insensitive (fast, using BLADE and PACE triggering)
Dot Decisions	<p>Your decisions can be seamlessly integrated into the scanning workflow. The user just selects the queue, and the appropriate protocol or set of protocols are added automatically. For the abdomen MRCP and Diffusion decision points are offered.</p>
MRCP decision point	<p>Dot provides comprehensive guidance, including positioning help. MRCP is measured and Inline Radial Ranges are generated in-line.</p>
Timeline monitoring	<p>For best overview of multi-phase breath-hold examinations, the contrast media enhancement curve is visualized.</p>
Automatic timing	<p>Liver dynamics is done using the care bolus approach. Auto Bolus Detection enables the system to monitor the arrival of contrast agent in a user defined ROI. When "Auto Bolus Detection" is enabled, Auto ROI can be enabled in the patient view, which allows the system to perform an automatic ROI positioning on the descending aorta at the level of the diaphragm. The ROI positioning can be confirmed and adjusted by the user.</p>
Bolus Timing	<p>An alternative way of performing liver dynamics. The optimal time window for data acquisition is derived by the system after the application of a test bolus. Visual guidance and interactive evaluation during the setup provide ease-of-use.</p>
AutoVoiceCommands	<p>Seamlessly integrated into the scanning workflow. The system plays them automatically at the desired time point. This assists the user in providing the optimal timing of scanning, breathing and contrast media. The user can monitor which breathhold or pauses are actually played, and add pauses between the automatic breath hold commands if necessary.</p>

Abdomen Dot Engine (Continued)

Inline Subtraction	Within the contrast-enhanced abdomen exam, multiple phases are acquired: native, arterial phase, portal-venous phase and late-phase. The scanner automatically subtracts the native measurement from the arterial, portal-venous and late phase.
Inline Registration	For best visualization of lesions the system can be set to automatically perform a registration/alignment of the anatomy for the different dynamic phases. The importance of registration/correction can be seen when examining nodular enhancing pathologies.
Customization	<p>Taking full advantage of the new Dot configuration platform. Providing various guidance and customization options, featuring "AutoTiming", "Auto Coverage", "Local Voice Command", etc.</p> <p>Existing Dot Engines can be adapted by the user to their individual standard of care.</p> <ul style="list-style-type: none">• Add/remove protocol steps• Change guidance content (images and text)• Change or add Dot Exam Strategies and Decision Points• Modify the Parameter View• Dot Library – alternative protocols with preconfigured add-ins. Only simple drag&drop needed.
LiverLab ¹⁾	<p>LiverLab is a system guided workflow to examine the hepatic fat and iron status, as part of the Abdomen Dot Engine.</p> <p>Main Features:</p> <p>The inline First look Dixon sequence gives the user a first overview of possible fat and/or iron overload in the whole liver. Based on the resulting images, liver segmentation runs without user interaction.</p> <p>If further evaluation is needed, the user can choose from two methods:</p> <ul style="list-style-type: none">• HISTO is a push-button single breathhold single voxel spectroscopy method to calculate fat signal fraction as well as water R2.• Multi-echo Dixon VIBE is an image based method to calculate maps such as water, fat, fat signal fraction, and R2*.

¹⁾ Optional

TimCT Onco Dot Engine¹⁾



TimCT Oncology employs the revolutionary TimCT Continuous

Table move technology for large Field of View applications with smooth workflow and excellent image quality. TimCT Oncology is built on Tim technology as well as on a highly advanced patient table with high positioning accuracy and an RF shielded table drive. Simultaneous coverage of a large Field of View using local coils with a high signal-to-noise ratio enables excellent image quality and extremely fast imaging with iPAT.

TimCT Oncology allows a CT-like MR examination:

- Definition of just the start point and end point of the scan area
- No need to plan in multiple steps
- No need to plan overlapping areas
- No delay, no measurement pauses during table move
- No need for composing

TimCT Onco Dot Engine makes the easy workflow of TimCT even easier by customizable guidance throughout the exam.

Guidance View	Step-by-step user guidance is seamlessly integrated. Example images and guidance text are displayed for each individual step of the scanning workflow. Both images and text are easily configurable by the user.
Parameter View	The new streamlined Parameter View displays the parameters that are really needed for the scan set-up. If desired, the user can switch to the conventional – fully loaded – parameter view at any time.
iPAT compatibility	Enabled by Tim 4G
Seamless scanning	Enables high image homogeneity and suppression of boundary artifacts

¹⁾ Optional; Prerequisite: Abdomen Dot Engine

TimCT Onco Dot Engine (Continued)

Special features	The possibility of shorter examination times, the BLADE technique and the suppression of boundary artifacts.
Liver dynamics	Key functionalities of the Abdomen Dot Engine are integrated.
Techniques	<p>The protocols are based on axial 2D T1-weighted FLASH- and T2-weighted imaging (TSE with and without BLADE and HASTE). This technique suits best as a complement to the primary tumor diagnosis done in stationary mode (e.g. in the upper abdomen) by providing comprehensive metastasis and lymph node evaluation in thorax-abdomen-pelvis.</p> <p>The following fat saturation techniques are available:</p> <ul style="list-style-type: none">• T1 FLASH with FatSat, SPAIR or Dixon, 4 contrasts in one scan• T2 HASTE with FatSat, SPAIR or Inversion Recovery• T2 TSE (with and without BLADE) with FatSat, SPAIR or STIR
Customization	<p>Existing Dot Engines can be adapted by the user to their individual standard of care.</p> <ul style="list-style-type: none">• Add/remove protocol steps• Change guidance content (images and text)• Change or add Dot Exam Strategies and Decision Points• Modify the Parameter View• Dot library (alternative sequences with preconfigured add-ins)

Angio Dot Engine¹⁾



The timing of contrast injection and scan is commonly stated the most challenging part of an angiographic exam. The Angio Dot Engine guides the user through angiographic single or multi station examinations by providing visualization of arterial and venous timing windows using a test bolus technique. This information is fed back into the next planning steps so scan parameters can be adapted to the individual patient and patient's condition. Where needed, automatic voice commands support the communication with the patient

Guidance View	Step-by-step user guidance is seamlessly integrated. Example images and guidance text are displayed for each individual step of the scanning workflow. Both images and text are easily configurable by the user
Parameter View	The new streamlined Parameter View displays the parameters that are really needed for the scan set-up. If desired, the user can switch to the conventional – fully loaded – parameter view at any time.
Test bolus	Visual display of of arterial/venous timing window
Feedback of bolus timing information	Timing information is fed back into planning steps and parameters can be adapted automatically
AutoVoiceCommands	Integrated into the scanning workflow. The system plays them automatically at the right point in time. This ensures optimal timing of scanning, breathing and contrast media. The user can monitor which breath hold or pauses are actually played, and could add pauses between the automatic breath hold commands if necessary
Customization	Existing Dot Engines can be modified by the user to their individual standard of care. <ul style="list-style-type: none"> • Add/remove protocol steps • Change guidance content (images and text) • Change or add Dot Exam Strategies and Decision Points • Modify the Parameter View

¹⁾ Optional

TimCT Angio Dot Engine¹⁾



TimCT Angiography employs the revolutionary TimCT Continuous Table move technology for large Field of View angiographies with a smooth workflow and homogeneous image quality. TimCT Angiography is built on the Tim technology as well as on a highly advanced patient table with high positioning accuracy and an RF shielded table drive. Dot TimCT Angio makes TimCT even easier with guidance throughout the exam and by providing a visual display of arterial and venous timing windows using a test bolus technique. This information is fed back into the next planning steps so scan parameters can be adapted to the individual patient and patient's condition. Where needed, automatic voice commands support the communication with the patient.

Guidance View	Step-by-step user guidance is seamlessly integrated. Example images and guidance text are displayed for each individual step of the scanning workflow. Both images and text are easily configurable by the user.
Parameter View	The new streamlined Parameter View displays the parameters that are really needed for the scan set-up. If desired, the user can switch to the conventional – fully loaded – parameter view at any time.
AutoVoiceCommands	Integrated into the scanning workflow. The system plays them automatically at the right time point. This supports the synchronized timing of scanning, breathing and contrast media. The user can monitor which breath hold or pauses are actually played, and can add pauses between the automatic breath hold commands if necessary.
Test bolus	Automatic detection of arterial/venous timing window
Feedback of bolus timing information	Timing information is fed back into planning steps so parameters can be adapted automatically.

¹⁾ Optional; Prerequisite: Angio Dot Engine

TimCT Angio Dot Engine (Continued)

iPAT compatibility utilizing Tim's Matrix coils capabilities

Inline subtraction and Inline MIP of complete peripheral run off images

High image homogeneity and no boundary artifacts thanks to seamless TimCT scanning

Max. FoV of TimCT (depending on the resolution)	205 cm (with Tim Whole Body Suite ¹⁾) 140 cm (without Tim Whole Body Suite)
---	--

Table speed during angiographic measurements	Up to 5 cm/s with patient weight up to 250 kg (550 lbs)
--	---

Fast examination time for TimCT peripheral angiographic exam	40–70 s depending on resolution
--	---------------------------------

Customization	Existing Dot Engines can be modified by the user to their individual standard of care. <ul style="list-style-type: none">• Add/remove protocol steps• Change guidance content (images and text)• Change or add Dot Exam Strategies and Decision Points• Modify the Parameter View
---------------	--

¹⁾ Optional

Cardiac Dot Engine¹⁾



Cardiac examinations used to be the most complex exams in MR. Now the Cardiac Dot Engine supports the user in many ways. Using anatomical landmarks, standard views of the heart, such as dedicated long axis and short-axis views are easily generated and can easily be reproduced using different scanning techniques. Scan parameters are adjusted to the patient's heart rate and automatic voice commands are given. All of this takes most of the complexity out of a cardiac exam and supports customized workflows that are easy to repeat. Different workflows are supported:

- Functional evaluation
- Ischaemic Heart Disease
- Myocarditis

Patient View	Within the Patient View the user can easily tailor the exam to each individual patient (e.g. patient with arrhythmia, breath hold capability). Several pre-defined Dot Exam Strategies are integrated. The user just selects the appropriate strategy with one click and the queue and the complete scan set-up are automatically updated to the users pre-defined standard of care.
Guidance View	Step-by-step user guidance is seamlessly integrated. Example images and guidance text are displayed for the individual steps of the scanning workflow. Both images and text are easily configurable by the user.
AutoFoV (automatic Field of View calculation)	Based on the localizer images the optimal FoV is automatically estimated. In case the patient moves during the examination, this step can be repeated at any time.
Automated parameter adaptation	Scan parameters are automatically adapted to the patient's condition (heart rate etc.)
AutoAlign Heart	Based on the localizer images, automatic detection of the cardiac landmarks is obtained and used to optimally plan cardiac exams without user interaction. The fully automatic planning process results in 2-, 3- and 4-chamber view and a stack of short axis views. In case the patient moves during the examination, this step can be repeated at any time.
Automated localization	Automated localization of short-axis views
Guided slice positioning	Easy way to match slice positions (short-axis) between cine, dynamic imaging, tissue characterization
Cardiac Views	Easy selection of cardiac views (e.g. 3 chamber view) during scan planning

¹⁾ Optional

Cardiac Dot Engine (Continued)

Inline Ventricular Function Evaluation	Inline VF performs volumetric evaluation of cardiac cine data fully automatically right after image reconstruction. There is no user input necessary. If desired, inline calculated segmentation results can be loaded to 4D Ventricular Function Analysis for further review or processing.
Inline Time Course Evaluation	Automatic, real-time and motion corrected calculation of parametric maps with inline technology
Cardiac specific layout for the Exam task	Automatically chosen layouts show the new physio display and are configured for every step of the exam.
Automatic display of images	Automatic display of image in dedicated cardiac image orientations instead of the standard DICOM orientations.
Adaptive triggering	Acquisition adapts in realtime to heart rate variations for non-cine applications.
Automated Naming	Automated naming of series depending on cardiac views and contrast.
AutoVoiceCommands	AutoVoiceCommands are seamlessly integrated into the scanning workflow. The system plays them automatically at the desired time point. This ensures synchronized timing of scanning, breathing and contrast media. The user can monitor which breath-hold or pauses are actually played, and could add pauses between the automatic breath hold commands if necessary.
Dot Exam Strategies	The workflow can be personalized to the individual patient condition and clinical need. The following predefined strategies are included. They can be changed at any time during the workflow: <ul style="list-style-type: none">• Standard: Segmented acquisition• Limited patient capabilities: switch to realtime and single shot imaging if breath-hold is not possible or arrhythmias occur
Customization	Existing Dot Engines can be modified by the user to their individual standard of care. <ul style="list-style-type: none">• Add/remove protocol steps• Change guidance content (images and text)• Change or add Dot Exam Strategies and Decision Points• Modify the Parameter View

Breast Dot Engine¹⁾



The Breast Dot Engine provides optimized protocols for lesion evaluation and characterization as well as implant evaluation. For ease of use, different examination strategies (FatSat, non-FatSat, feet-first/head-first positioning, InterVIEWS) are available for both high-channel coils and the 4ch BI coil. For improvement of the biopsy workflow, different Biopsy Dot Engines are provided.

- High channel coils
- High channel coils CareBolus
- 4ch BI
- 4ch BI CareBolus
- Biopsy Sentinelle 2ch medial
- Biopsy Sentinelle 10/4ch medial
- Biopsy 4ch BI

Patient View	The user simply easily tailors the exam to the condition of each individual patient (e.g. patient with implants) and defines the examination approach (Carebolus, Autocoverage, Frequency Adjustment Confirmation Mode, Silicone Protocols, Inline MPR).
Implant situation	Based on an implant type identification scan, the user can visually select or modify the exam dependent on the actual implant type and laterality. The system automatically modifies the scan queue accordingly and the frequency adjustment setting of the protocols is changed (assume dominant fat or silicone). The user may change these modifications
Guidance View	Example images and guidance text are displayed for each individual step of the scanning workflow. Both images and text are easily configurable by the user.
Parameter View	This view displays the parameters that are really needed for the examination at a glance. The displayed parameters are easily configurable by the user. If desired, the user can switch to the conventional – fully loaded – parameter view at any time.

¹⁾ Optional

Breast Dot Engine (Continued)

Autocoverage	Based on the localizer data, an automatic segmentation is performed, which allows the estimation of the optimal FoV (entire FoV for both breasts, right or left breast, breast with chest) and which is used to adapt automatically the size of the adjust volume to the patient's anatomy. The user can predefine for every protocol individually which parameters shall be adjusted automatically, e.g. whether time or slice thickness shall remain constant.
AutomaticBolusDecton	Optional functionality for easy interaction and operator-independent timing of the dynamic scan: determination of the bolus arrival time in the heart (by using a care bolus sequence), and automatic initiation of the dynamic protocol. Visual monitoring of the signal intensity allows a manual override.
MPR Planning	For user-selected protocols, e.g. the high resolution "delayed VIEWS", adjustable MPRs are calculated automatically.
Biopsy support	Supporting interventions with the 2/4/8 ch and 2/10/16 ch Sentinelle Breast and 4ch BI Breast coils. In case the Breast Biopsy or BreVis Biopsy planning software is used, the target coordinates of the lesion are displayed on the Dot display at the scanner.
Single frequency adjust	The user can preselect to show the frequency adjustment dialogue only once for the exam queue. This preselection stays valid until a new coil combination or deviating z-position is used.
Customization	Existing Dot Engines can be modified by the user to their individual standard of care. <ul style="list-style-type: none">• Add/remove protocol steps• Change guidance content (images and text)• Change or add Dot Exam Strategies and Decision Points• Modify the Parameter View

Spine Dot Engine¹⁾



The Spine Dot Engine delivers optimized cervical, thoracic and lumbar spine imaging for patients of all conditions and provides guided and automated workflows customized to your standards of care. The Spine Dot Engine supports the user in achieving reproducible image quality with increased ease of use and time efficient exams.

Patient View	Within the Patient View the user can easily tailor examinations to an individual patient. Dot Exam Strategies allow you to choose the most appropriate strategy with one mouse click, the complete scan setup is then automatically prepared.
Guidance View	Step-by-step user guidance can be seamlessly integrated. Example images and guidance text can be displayed for each individual step of the scanning workflow to ensure perfect scanning even by novice operators. Both images and text are easily configurable by the user.
Parameter View	The new streamlined Parameter View displays a user-defined subset of parameters which are available for manual protocol optimization. If desired, the user can switch to the conventional – fully loaded – parameter view at any time.
AutoPosition	The C, T or L spine of the patient is automatically placed at the isocenter without any laser marking required.
AutoAlign Spine LS	Automated, positioning and alignment of slice groups to the spine anatomy, relying on multiple anatomical landmarks. Provides fast, easy, and reproducible patient scanning and facilitates the reading by consistently delivering high image quality with a standardized slice orientation, both for follow-ups and across patients. AutoAlign Spine LS automatically detects and labels vertebra and body disks, suggests positioning for sagittal, coronal and double oblique axial slices in the spine, and automatically positions the saturation region.
AutoLabeling	Automatic labeling of vertebra for easier examination planning and faster reading

¹⁾ Optional

Spine Dot Engine (Continued)

Interactive Snapping	Just drag the slide group over the sagittal plane. AutoAlign Spine LS delivers automatic double oblique positioning of axial slice groups to intervertebral disk layers.
AutoCoverage	Maximizes the speed of the examination by automatically setting the number of slices and the FoV to fully cover the C, T or L-spine. This is performed based on the information delivered by AutoAlign Spine LS, eliminating manual setting and the scanning of unnecessary slices.
Dot Exam Strategies	Examinations can be easily personalized to the individual patient condition and clinical need. The Spine Dot Engine comes with the following predefined examination strategies, which the user can select according to patient conditions or change at any time during the workflow, when conditions change: <ul style="list-style-type: none">• Standard: for fast routine spine examinations• Post surgery: for detailed evaluation of spine including fat saturation and DIXON techniques.• High Bandwidth (WARP¹⁾) : Optimized strategy for the reduction of susceptibility artifacts.
WARP	WARP integrates different techniques tailored to reduce susceptibility artifacts caused by orthopedic MR-Conditional ¹⁾ metal implants. 2D TSE sequence combining optimized high-bandwidth protocols and View Angle Tilting (VAT) technique, helps in evaluation of soft tissue in proximity of the implant.

¹⁾ MR imaging of patients with metallic implants brings specific risks. However, certain implants are approved by the governing regulatory bodies to be MR conditionally safe. For such implants, the previously mentioned warning may not be applicable. Please contact the implant manufacturer for the specific conditional information. The conditions for MR safety are the responsibility of the implant manufacturer, not of Siemens.

Spine Dot Engine *(Continued)*

Rerun	An image inside the examination UI can be selected and a rerun of the corresponding series can be triggered with identical sequences or parameters.
Inline Curved reconstructions	Automatic curved reconstruction from 3D acquisitions by using the position information from the AutoAlign Spine LS algorithm.
Customization	<p>The Spine Dot Engine can be easily modified by the user to their individual standard of care.</p> <ul style="list-style-type: none">• Add/remove protocol steps• Change guidance content (images and text)• Change or add Dot Exam Strategies• Add clinical decision points• Add/remove parameters in the parameter viewing card• User-defined offsets to the standard positions delivered by AutoAlign Spine LS(also for the saturation region)• Customized inline curved and MPR reconstructions

syngo MR Software

syngo MR Examination

AutoScout	<ul style="list-style-type: none">• Automatic start of localizer scan with very short acquisition time• Arbitrary orientations (multi-slice multi-angle)• Automatically loads images into Graphical Slice Positioning
Graphical Slice Positioning	<p>Simultaneous use of three arbitrary localizer images from possibly different measurements for graphically positioning slices and sat regions. Interactive modification of measurement parameters (slice thickness, distance factor, oversampling etc.):</p> <ul style="list-style-type: none">• Automatic selection of relevant coil elements• Graphical selection of coil elements• Off-center positioning (shift of FoV within the selected slice position)• True multi-slice multi-angle, e.g. simultaneous measurement of multiple images (stacks with different orientation)• Recall of previous slice and/or sat region positioning• Paging through all images during graphical positioning• Inline Movie, allowing positioning of slices on e.g. the beating heart• Loads images immediately when they are available, e.g. during image reconstruction• Allows quick overview via image stamps. Loads entire series of planning images with drag-and-drop• Slice positioning (GSP) on 3D reconstructed images• Slice positioning (GSP) on 2D and 3D distortion corrected images• Slice positioning (GSP) on composed images

syngo MR Image Viewing and Filming

Image Display	<ul style="list-style-type: none">• Various display layouts selectable• Up to 3 patients can be simultaneously active in the viewer• Image annotation and labeling• Non-interpolated display• Fast paging through up to 500 images with 15 images/s for full screen display
Windowing	<ul style="list-style-type: none">• Freely selectable window width and center• Windowing on succeeding images• Auto-windowing for optimized contrast• Saves and sends window values
Automatic Movie for cine display	
Interactive movie paging by dragging the mouse or Automatic Movie mode by clicking the icon	
Evaluation	Parallel evaluation of up to 40 regions of interest <ul style="list-style-type: none">• Circle• Rectangle• Freehand ROI• Pixel lens with position marker• Statistical evaluation• Area• Standard deviation• Mean value• Min/max values• Image scrolling• Magnification• Distance• Angle
2D Post-processing	Image manipulations <ul style="list-style-type: none">• Reversal of gray-scale values• Image rotation by 90° or by user-defined angle• Flip horizontally/vertically• Image zoom and pan• Shutter• Annotation
Position display	Displays measured slice positions on localizer image and selected series.

syngo MR Image Viewing and Filming (Continued)

Argus Viewer	Viewing software for cardiac MR studies and large data sets <ul style="list-style-type: none"> • Efficient cine review of cardiac and other dynamic data sets • Multiple sorting options • Single movie as well as 2, 4, or 8 simultaneous slices together in movie mode • Rapid avi creation of 1 to 8 slices simultaneously • Creates and edits DICOM structured reports 				
Mean Curve	Time-intensity analysis for contrast-enhanced examinations <ul style="list-style-type: none"> • Creates and edits DICOM structured reports 				
Filming	<ul style="list-style-type: none"> • Connection via DICOM Basic Print • Interactive filming • Filming parallel to other activities • Independent scanning and documentation – no wait time due to camera delays • Freely selectable positioning of images onto virtual film sheet • Selectable various film layouts • Mother-in-Child display • Windowing, image zoom and pan on film sheet • Configurable image text • Simultaneous handling of multiple film jobs • Up to 100 virtual film sheets 				
Dynamic Analysis	<p>Arithmetic operations on images and series (e.g. for evaluation of contrast media studies)</p> <ul style="list-style-type: none"> • Addition, subtraction, multiplication, division of single images and whole series • Arithmetic mean and standard deviation across a range of selected images • Calculation of T1 and T2, and logarithmic images • Differentiation/integration of selected images • Calculation of a mean slope image from a range of selected images • Calculation of z-score (t-test) images for evaluation of BOLD imaging data (Blood Oxygenation Level Dependent) • Time-to-peak evaluation (TTP) • ADC maps <p>Several evaluation functions may be started consecutively in the background</p>				
Printing on Paper	<p>Interface and software for printing images on paper (laser printer not included)</p> <table border="1"> <tr> <td>Supported printing</td> <td>Grey levels and color</td> </tr> <tr> <td>Data format</td> <td>PostScript Level 2</td> </tr> </table>	Supported printing	Grey levels and color	Data format	PostScript Level 2
Supported printing	Grey levels and color				
Data format	PostScript Level 2				

syngo MR 3D Post-processing

MPR – Multi-Planar Reconstruction	Real-time multi-planar reformatting of secondary views <ul style="list-style-type: none">• Viewing perspectives: sagittal, coronal, axial, oblique, double oblique, curved (freehand)• Reconstruction along polygon and/or curved (freehand) cut lines• Reconstruction based on reconstructed planes possible• Reconstruction of user-defined ranges of parallel, radial or freehand cuts• Selectable slice thickness and slice increment of reconstructed images• Storing of post-processing protocols• Annotations and 2D evaluations such as distance and ROI
MIP – Maximum Intensity Projection	3D reconstructions of vessels from a 3D data set, or a 2D sequential slice data set (acquired with dedicated MR Angiography sequences) <ul style="list-style-type: none">• Volume of Interest (VoI) defined to increase reconstruction speed and to improve image quality• Freehand MIP• Arbitrary views along any direction can be defined interactively with mouse-driven virtual trackball• Multiple view angles around any orthogonal axis• Projections displayed as single images, as interactive movie or by fast paging• MIP thin/MIP thick
MinIP – Minimum Intensity Projection	Similar to MIP but reconstructs the minimum intensity (e.g. for Dark Blood techniques)
SSD – Shaded Surface Display	Three-dimensional display of surfaces, such as contrast-enhanced vessels <ul style="list-style-type: none">• Selectable variable threshold values• Multiple view angles around any orthogonal axis
Volumes of Interest (VoI)	Rectangular and irregular VoI can be defined to improve image quality

syngo MR Network Communication

DICOM Services
(Digital Imaging and
Communications in
Medicine)

Interface for transmitting medical images and information in the DICOM 3.0 industrial standard. Allows for communication between devices from different manufacturers

- DICOM Send/Receive
- DICOM Query/Retrieve
- DICOM SC Storage commitment
- DICOM Basic Print
- DICOM Modality Worklist
- DICOM MPPS Modality performed procedure steps. Communication back to information system
- DICOM Structured Reports
- DICOM Study Split

DICOM Study Split

DICOM Study Split provides the mapping of one study acquired based on multiple requests to multiple studies directly at the scanner. For example, two requests for head and neck acquisition can be registered once, scanned once and immediately mapped to two separate studies for individual reading.

Multiple requested procedures can be combined in a time saving manner by scanning a larger body region and then splitting them to individual billing relevant studies for separate reading.

This package allows:

- Time saving simple mapping of multiple requested procedures to multiple acquired series with one scan
- Simple creation of studies with individual billing based on one scan workflow
- Improvement for departmental workflow by eliminating need to load/change and to request/execute splitting on a separate workstation after the scan
- Immediate visual selection, check and correction of images to study assignments.
- Overlapping region images can be copied to both studies

syngo MR Network Communication (Continued)

syngo MR Network Communication	Exchange Media Storage of images and additional data (e.g. avi files) on CD/DVD	
DICOM Viewer	A viewing tool which can be stored together with images on a DICOM CD/DVD to be handed out to the patient	
Virus Protection	<ul style="list-style-type: none"> • Permanent scanning for malicious software in the background to provide maximum security • Via Remote Access over secure network connection the latest virus scanner updates and operating system hotfixes are installed automatically • Provided in conjunction with a service contract with Siemens (UPTIME Services) 	
Image Transfer	Local network	Ethernet
	Data transfer rate	Max. 1 Gbit/s
	Transfer rate (256×256 image)	Approx. 60 images/s

Computer System

syngo Acquisition Workplace																			
General	Full multi-tasking for simultaneous functionality, e.g.: <ul style="list-style-type: none"> • Patient registration and pre-registration • Scanning • Reconstruction • Viewing • Post-processing • Filming • Data storage 																		
Color LCD Monitor	High resolution flicker-free flat-screen monitor Horizontally tiltable, forward and backward Automatic backlight control for long-term brightness stability Optional second monitor																		
	<table border="1"> <tr> <td>Screen size (diagonal)</td> <td>19"</td> </tr> <tr> <td>Horizontal frequency</td> <td>30-85 kHz</td> </tr> <tr> <td>Vertical frequency</td> <td>50–75 Hz</td> </tr> <tr> <td>Screen matrix</td> <td>1280×1024</td> </tr> </table>	Screen size (diagonal)	19"	Horizontal frequency	30-85 kHz	Vertical frequency	50–75 Hz	Screen matrix	1280×1024										
Screen size (diagonal)	19"																		
Horizontal frequency	30-85 kHz																		
Vertical frequency	50–75 Hz																		
Screen matrix	1280×1024																		
Host computer	<table border="1"> <tr> <td>Processor</td> <td>Intel Xeon E5-1620 Quad-Core</td> </tr> <tr> <td>Clock rate</td> <td>≥3.6 GHz</td> </tr> <tr> <td>RAM</td> <td>32 GB</td> </tr> <tr> <td>1st hard disk (system SW)</td> <td>≥300 GB SAS</td> </tr> <tr> <td>2nd hard disk (data base)</td> <td>≥300 GB SAS</td> </tr> <tr> <td>3rd hard disk (images)</td> <td>≥300 GB SAS</td> </tr> <tr> <td>CD-R writer</td> <td>Approx. 4000 images 256² DICOM Standard, ISO 9660</td> </tr> <tr> <td>DVD-R writer</td> <td>Approx. 25 000 images 256² DICOM Standard, ISO 9660</td> </tr> <tr> <td>Media drives</td> <td>CD/DVD drive</td> </tr> </table>	Processor	Intel Xeon E5-1620 Quad-Core	Clock rate	≥3.6 GHz	RAM	32 GB	1 st hard disk (system SW)	≥300 GB SAS	2 nd hard disk (data base)	≥300 GB SAS	3 rd hard disk (images)	≥300 GB SAS	CD-R writer	Approx. 4000 images 256 ² DICOM Standard, ISO 9660	DVD-R writer	Approx. 25 000 images 256 ² DICOM Standard, ISO 9660	Media drives	CD/DVD drive
Processor	Intel Xeon E5-1620 Quad-Core																		
Clock rate	≥3.6 GHz																		
RAM	32 GB																		
1 st hard disk (system SW)	≥300 GB SAS																		
2 nd hard disk (data base)	≥300 GB SAS																		
3 rd hard disk (images)	≥300 GB SAS																		
CD-R writer	Approx. 4000 images 256 ² DICOM Standard, ISO 9660																		
DVD-R writer	Approx. 25 000 images 256 ² DICOM Standard, ISO 9660																		
Media drives	CD/DVD drive																		

syngo Acquisition Workplace (Continued)		
Measurement and reconstruction system	Processor	Intel E5-2620 2 x 6-Core
	Clock rate	2.0 GHz, or comparable
	Main memory (RAM)	48 GB
	Hard disk for raw data	≥300 GB
	Hard disk for system software	≥100 GB
	Parallel Scan & Recon	Simultaneous scan and reconstruction of up to 8 data sets
	Reconstruction speed	25 556 recons per second (256 ² FFT, full FoV) 88 889 recons per second (256 ² FFT, 25% recFoV)
syngo MR Workplace¹⁾		
Color LCD Monitor	High resolution flicker-free flat-screen monitor Horizontally tiltable, forward and backward Automatic backlight control for long-term brightness stability Optional second monitor	
	Screen size (diagonal)	19"
	Horizontal frequency	30-85 kHz
	Vertical frequency	50–75 Hz
	Screen matrix	1280×1024
Host computer	Processor	Intel Xeon E5-1620 QuadCore
	Clock rate	≥3.6 GHz
	RAM	≥8 GB
	1 st hard disk (system SW)	≥300 GB SAS
	2 nd hard disk (data base)	≥300 GB SAS
	CD-R writer	Approx. 4000 images 256 ² DICOM Standard, ISO 9660
	DVD-R writer	Approx. 25 000 images 256 ² DICOM Standard, ISO 9660
Media drives	CD/DVD drive	

¹⁾ Optional

Installation

Radio Frequency Shielding	
For shielding the examination room from external RF sources	
RF attenuation factor	>90 dB
Frequency range	15–65 MHz
Magnetic Shielding	
Room shielding	For additional reduction of the magnetic fringe field, suitable iron shielding can be installed in the walls of the examination room. The room shielding can be used to create a magnetic shielding enclosure
One-Floor Installation	A combination of active shielding and a special shielding installed on the ceiling of the magnet room or below it will keep the 0.5 mT line within the same floor as MAGNETOM Avanto ^{fit} , even in case of very low room heights
System Electronics Cabinets	
Two cabinets which may be placed directly against the wall or even in a corner	
Require service access only from the front, saving considerable space	
Integrated water cooling cabinet may eliminate the need for a dedicated computer room	
Power Requirements	
Line voltage	380, 400, 420, 440, 460, 480 V
Stability tolerances	±10%
Line frequency	50/60 Hz, ±1 Hz
Connection value ¹⁾	110 kVA

¹⁾ Long-term average in full operation

Cooling Water Requirement		
Water cooled cabinet	Water consumption	>90 l /min ¹⁾
	Heat dissipation to water	Maximum ≤60 kW
Power Consumption ²⁾		
System off ³⁾		6.1 kW
Ready for measurement ³⁾		9.3 kW
Typical measurement ³⁾		19.0 kW
Space Requirements		
Min. total space requirement (for magnet, electronics, and console room)		≤27 m ² (290 sq ft)

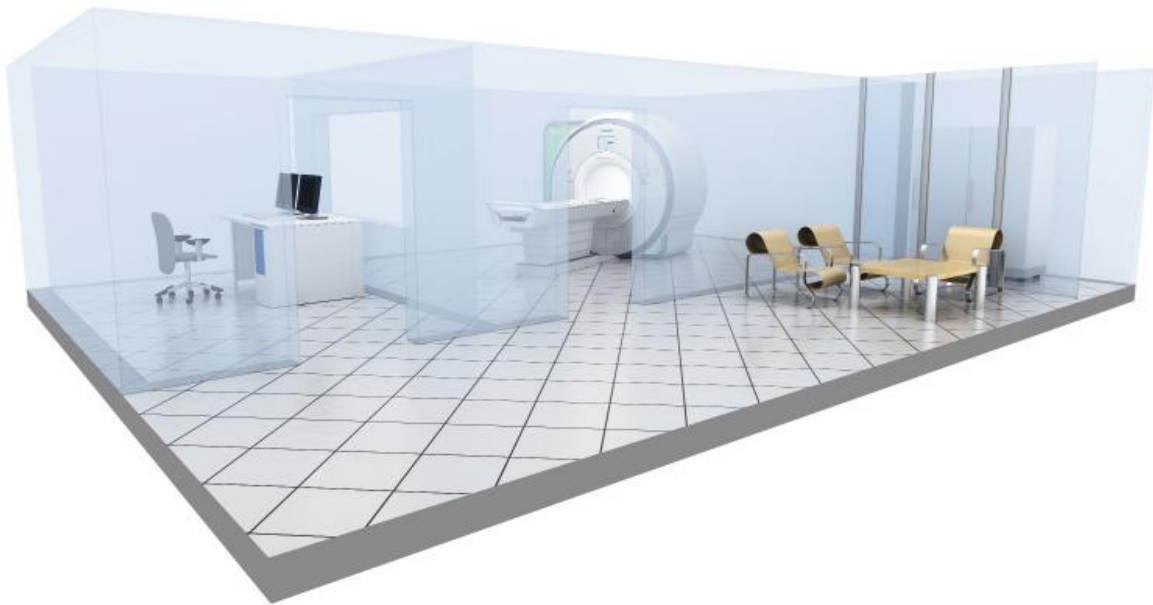

¹⁾ Water temperature: 6 –12 °C (43–54 °F)

²⁾ All values are typical values, applicable for 400V and 50Hz; Consumption for optional separator pump not included

³⁾ The power consumption described herein is based on results that were achieved in a setting according to the COCIR methodology MRI-Measurement of the energy consumption (<http://www.cocir.org/site/index.php?id=46>). Since many variables impact power consumption (e.g. sequences used for scanning and sequence parameters, scan time), there can be no guarantee that each customer will achieve the same values.

Dimensions					
	Component	Width [cm]	Depth [cm]	Height [cm]	Weight [kg]
Examination Room	Magnet 1.5 Tesla AS (incl. Helium)	207	150	210	3875±80
	Magnet in operation, incl. gradient coil, body coil and covers	238.5	408	220	5292
	Patient table	76	249	52-102	
	Required min. room height clearance			235	
	Min. transport dimensions (only for factory upgrade. Field upgrade suitable for standard doors 120cm x 198cm)	tbd*	tbd*	tbd*	
Control Room	<i>syngo</i> Acquisition Workplace (table + monitor)	120	80	118 (71+47) fixed desk 157 (110+47) height adjustable desk	
	Host computer	17	46	46	
	<i>syngo</i> MR Workplace (optional) (table + monitor)	120	80	118 (71+47) fixed desk 157 (110+47) height adjustable desk	
Equipment Room	Electronics cabinet, incl. system control, RF system, gradient power system, image processor	160	65	198**	1500
	Cooling system	65	65	189**	500
	Heat dissipation ≤ 5 kW, only ventilation might be required				

* Without covers, electronics, table and table bracket

** Without attachments

System Cover

Different design variants are available for customer specific needs

Standard variant:
Pure White Design with
brilliant front ring



Optional color and
Illumination MoodLight™
variants with brilliant front
rings are available



Water Blue Design
with brilliant front ring



Light Green Design
with brilliant front ring



Illumination MoodLight with or without Customized Logo
with brilliant front ring



Not for distribution in the US.

The products/features (here mentioned) are not commercially available in all countries. Due to regulatory reasons their future availability cannot be guaranteed. Please contact your local Siemens Healthcare organization for further details.

The information in this document contains general technical descriptions of specifications and options as well as standard and optional features which do not always have to be present in individual cases.

Original images always lose a certain amount of detail when reproduced

Siemens Healthcare reserves the right to modify the design, packaging, specifications and options described herein without prior notice. Please contact your local Siemens Healthcare sales representative for the most current information.

Note: Any technical data contained in this document may vary within defined tolerances.

Please find fitting accessories:
[healthcare.siemens.com/
accessories-oem-equipment](http://healthcare.siemens.com/accessories-oem-equipment)

Siemens Healthcare Headquarters

Siemens Healthcare GmbH
Henkestr. 127
91052 Erlangen
Germany
Telephone: +49 9131 84-0
siemens.com/healthcare

Legal Manufacturer

Siemens Healthcare GmbH
Henkestr. 127
91052 Erlangen
Germany

[siemens.com/avanto-fit](https://www.siemens.com/avanto-fit)

MAGNETOM Avanto^{fit}

Tim Dockable Table

General

Comfortable patient table fitting the needs for patients up to 250 kg/550 lb.

- Integrated coils for fast patient preparation and enhanced user comfort
- Integrated arm boards for IV injection
- Integrated infusion stand

General (Continued)

- 360° maneuverability with integrated navigation wheel
- Fast dock/undock functionality
- Integrated safety rails
- Compatible with TimCT
- Compatible with Tim 4G coils

Tim Dockable Table

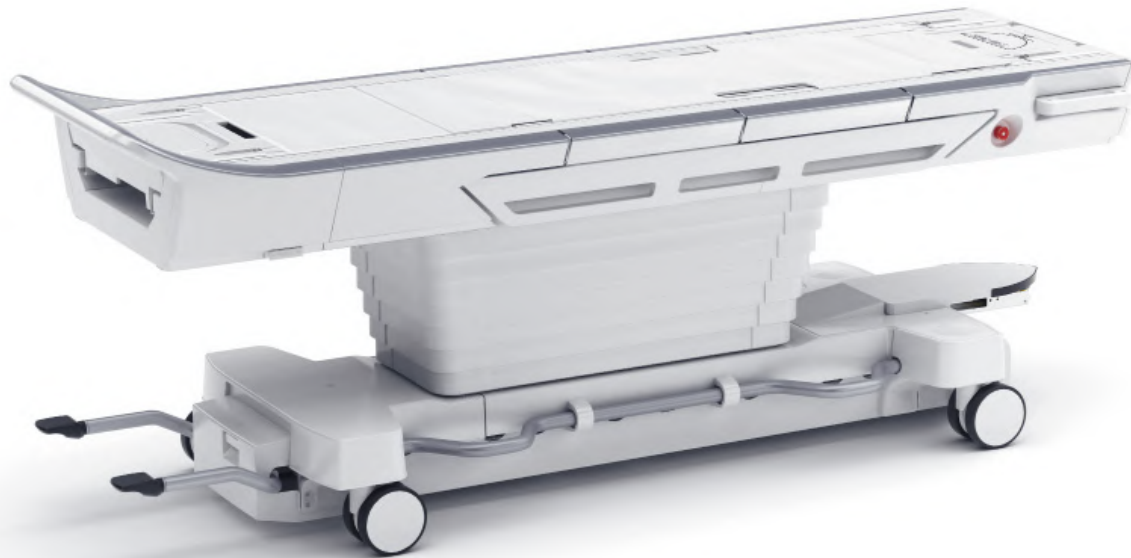

Technical Data	
Max. patient weight for vertical and horizontal table movement	250 kg ¹⁾ (550 lbs)
Max. scan range	140 cm 205 cm ²⁾
User can adjust the table speed with two predefined speed modes or accelerate continuously via Dot Control Centers	

Technical Data		
Vertical table movement	Range	56–106 cm ³⁾ +13 mm ⁴⁾
	Speed	60 mm/s; one click table up
Horizontal table movement	Max. range	2610 mm
	Max. speed	200 mm/s
Position accuracy ⁵⁾		±0.5 mm
Continuous table movement during scan capable		

¹⁾ When used with MAGNETOM Avanto^{fit}, patient weight is limited to 200 kg (440 lbs)

²⁾ With Tim Whole Body option

³⁾ Including Heightening Kit, if necessary

⁴⁾ Depending on the floor conditions

⁵⁾ Horizontal accuracy for repositioning from one direction

Siemens Healthcare Headquarters
Siemens Healthcare GmbH
Henkestr. 127
91052 Erlangen
Germany
Telephone: +49 9131 84-0
siemens.com/healthcare

Legal Manufacturer
Siemens Healthcare GmbH
Henkestr. 127
91052 Erlangen
Germany

[siemens.com/avanto-fit](https://www.siemens.com/avanto-fit)

MAGNETOM Avanto^{fit}

Head/Neck 20

General

The Head/Neck 20¹⁾ is part of the standard system configuration

- 20-channel design with 20 integrated pre-amplifiers, two rings of 8 elements each and one ring with 4 elements
- Cable-less coil with DirectConnect™ technology
- Combined coil for head and neck examination for optimized workflow
- Upper coil part easily removable
- Lower coil part usable without upper part for highly claustrophobic patients
- Lower coil part may stay on the patient table for most of the examinations
- Smoothly integrated into the patient table with Spine 32
- Open patient-friendly design
- Cushioned head stabilizers (removable)
- No coil tuning
- iPAT-compatible in all directions
- Dual-Density Signal Transfer enables ultra-high density coil designs by integrating key RF components into the local coil
- Detachable double mirror

Applications

- Head examination
- Neck examination
- MR Head/Neck Angiography
- Combined head/neck examination
- TMJ (temporomandibular joints)

Typically combined with

- Spine 32
- Body 18
- Peripheral Angio 36 (optional)
- Flex Large 4
- Flex Small 4
- Loop 1.5T coils (optional)

Head/Neck 20

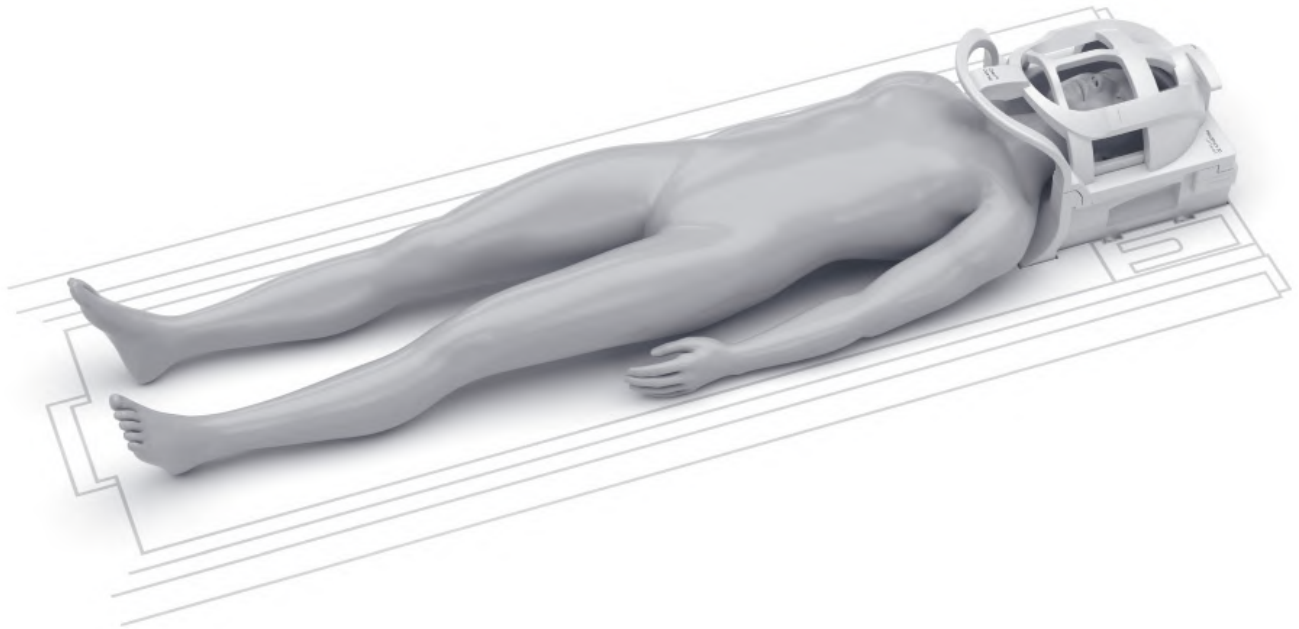

Weight

Total	4.7 kg
Anterior part	1.7 kg

Dimensions (L x W x H)

440 mm x 330 mm x 370 mm

Siemens Healthcare Headquarters

Siemens Healthcare GmbH
Henkestr. 127
91052 Erlangen
Germany
Telephone: +49 9131 84-0
siemens.com/healthcare

Legal Manufacturer

Siemens Healthcare GmbH
Henkestr. 127
91052 Erlangen
Germany

[siemens.com/avanto-fit](https://www.siemens.com/avanto-fit)

MAGNETOM Avanto^{fit}

Spine 32

General

The Spine 32 is part of the standard system configuration.

- 32-channel design with 32 integrated pre-amplifiers, 8 rows of 4 elements each
- Cable-less coil with DirectConnect™ technology
- Smoothly integrated into the patient table and streamlined with Head/Neck 20
- May remain on the patient table for nearly all exams
- No coil tuning
- iPAT-compatible in all directions
- Dual-Density Signal Transfer enables ultra-high density coil designs by integrating key RF components into the local coil

Applications

- High resolution imaging of the whole spine
- Various applications in combination with additional coils

Typically combined with

- Body 18
- Head/Neck 20
- Peripheral Angio 36 (optional)
- Flex Large 4
- Flex Small 4

Spine 32



Weight

11 kg

Dimensions (L × W × H)

1200 mm × 489 mm × 63 mm

Siemens Healthcare Headquarters

Siemens Healthcare GmbH
Henkestr. 127
91052 Erlangen
Germany
Telephone: +49 9131 84-0
[siemens.com/healthcare](https://www.siemens.com/healthcare)

Legal Manufacturer

Siemens Healthcare GmbH
Henkestr. 127
91052 Erlangen
Germany

[siemens.com/avanto-fit](https://www.siemens.com/avanto-fit)

MAGNETOM Avanto^{fit}

Body 6

General

- 6-channel design with 6 integrated pre-amplifiers, with 2 rows of 3 elements each
- Operates in an integrated fashion with the spine coil
- Can be combined with further Body 6 coils for larger coverage
- No coil tuning
- iPAT-compatible in all directions
- Dual-Density Signal Transfer enables ultra-high density coil design by integrating key RF components into the local coil.
- SlideConnect® technology for easy coil set up

Applications

- Thorax
- Heart
- Abdomen
- Pelvis
- Hip
- Vascular
- MRI in the context of neuro- and cardiovascular interventions

Typically combined with

- Additional Body 6 coils (optional)
- Peripheral Angio 36 (optional)
- Flex Large 4
- Flex Small 4
- Head/Neck 16 / Head/Neck 20
- Spine 32

Body 6

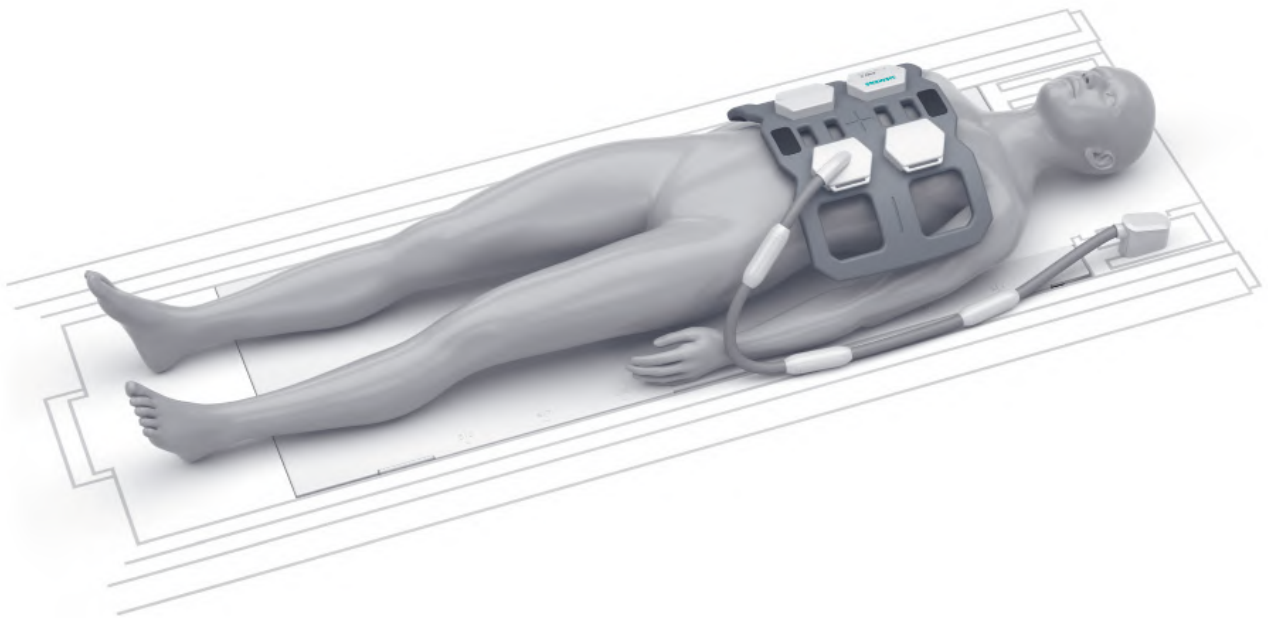

Weight

1.4 kg
"patient-felt" weight of coil only 0.8 kg

Dimensions (L x W x H)

322 mm x 533 mm x 70 mm

Siemens Healthcare Headquarters

Siemens Healthcare GmbH
Henkestr. 127
91052 Erlangen
Germany
Telephone: +49 9131 84-0
siemens.com/healthcare

Legal Manufacturer

Siemens Shenzhen Magnetic Resonance Ltd.
Siemens MRI Center, Gaoxin C. Ave. 2nd,
Hi-Tech Industrial Park
518057 Shenzhen
China

[siemens.com/avanto-fit](https://www.siemens.com/avanto-fit)

MAGNETOM Avanto^{fit}

Body 18

General

The Body 18 is part of the standard system configuration.

- 18-channel design with 18 integrated pre-amplifiers, with 3 rows of 6 elements each
- Operates in an integrated fashion with the Spine 32 for body imaging with 30 channels
- Can be combined with further Body 18 coils for larger coverage
- No coil tuning
- iPAT-compatible in all directions
- Dual-Density Signal Transfer enables ultra-high density coil design by integrating key RF components into the local coil.
- SlideConnect technology for easy coil set up

Applications

- Thorax
- Heart
- Abdomen
- Pelvis
- Hip
- Vascular

Typically combined with

- Head/Neck 20
- Spine 32
- Additional Body 18 coils (optional)
- Peripheral Angio 36 (optional)
- Flex Large 4
- Flex Small 4
- Loop 1.5T coils (optional)
- Endorectal coil (optional)

Body 18

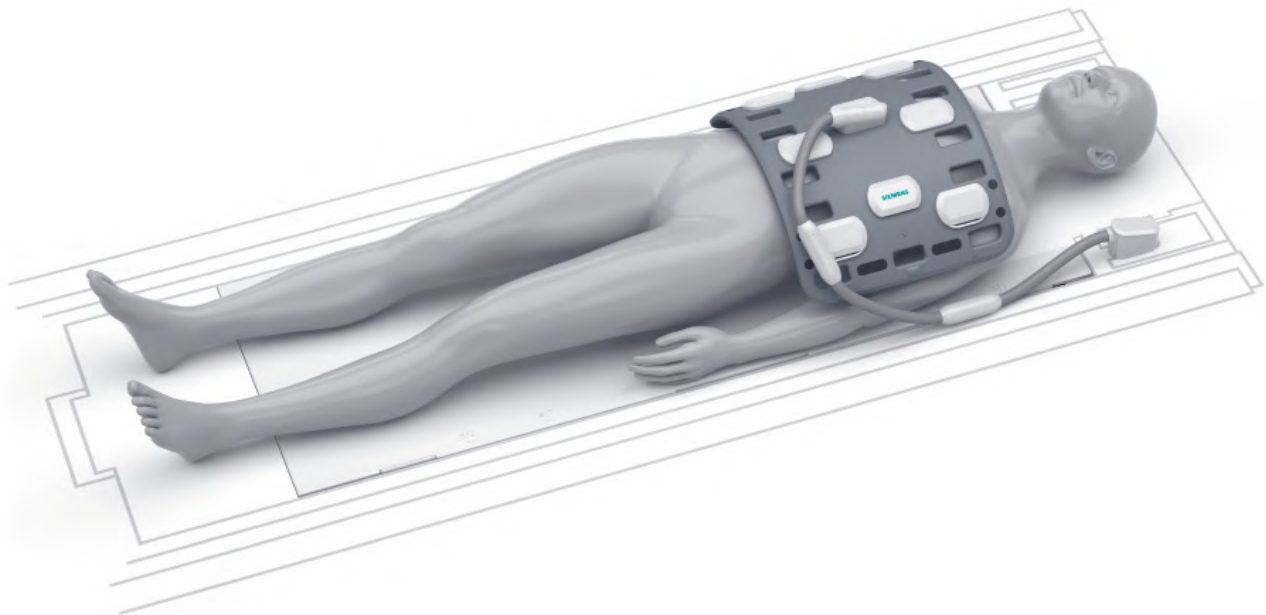

Weight

1.6 kg
"patient-felt" weight of coil only 1.1 kg

Dimensions (L x W x H)

385 mm x 590 mm x 65 mm

Siemens Healthcare Headquarters

Siemens Healthcare GmbH
Henkestr. 127
91052 Erlangen
Germany
Telephone: +49 9131 84-0
siemens.com/healthcare

Legal Manufacturer

Siemens Healthcare GmbH
Henkestr. 127
91052 Erlangen
Germany

siemens.com/avanto-fit

MAGNETOM Avanto^{fit}

Body 18 Long¹⁾

General

Body 18 coil with extended cable, especially suitable for therapy image guidance.

- 18-channel design with 18 integrated pre-amplifiers, with 3 rows of 6 elements each
- Operates in an integrated fashion with the Spine 32 for body imaging with 30 channels
- Can be combined with further Body 18 or Body 18 Long coils for larger coverage
- No coil tuning
- iPAT-compatible in all directions
- Dual-Density Signal Transfer enables ultra-high density coil design by integrating key RF components into the local coil.
- SlideConnect technology for easy coil set up

Applications

- MRI for RT image guidance
- MRI in the context of neuro- and cardiovascular interventions
- all Body 18 applications:
Thorax; Heart; Abdomen; Pelvis; Hip; Vascular

Typically combined with

- for Radiation Therapy imaging purposes:
 - Flex 4 coil(s)
 - Body 18 coil(s)
 - Spine 32 coil
- for imaging in the context of neuro- and cardiovascular interventions:
 - Body 18 coil(s)
 - Combi Coil Base (only in combination with the Combi Dockable Table; allows to combine the Body 18 Long with Body 18 and to use the combination as spine coil in situations where the patient is positioned on a transfer board so that the Spine 32 cannot be used)

¹⁾ Prerequisite: Tim [204x48]

Body 18 Long¹⁾

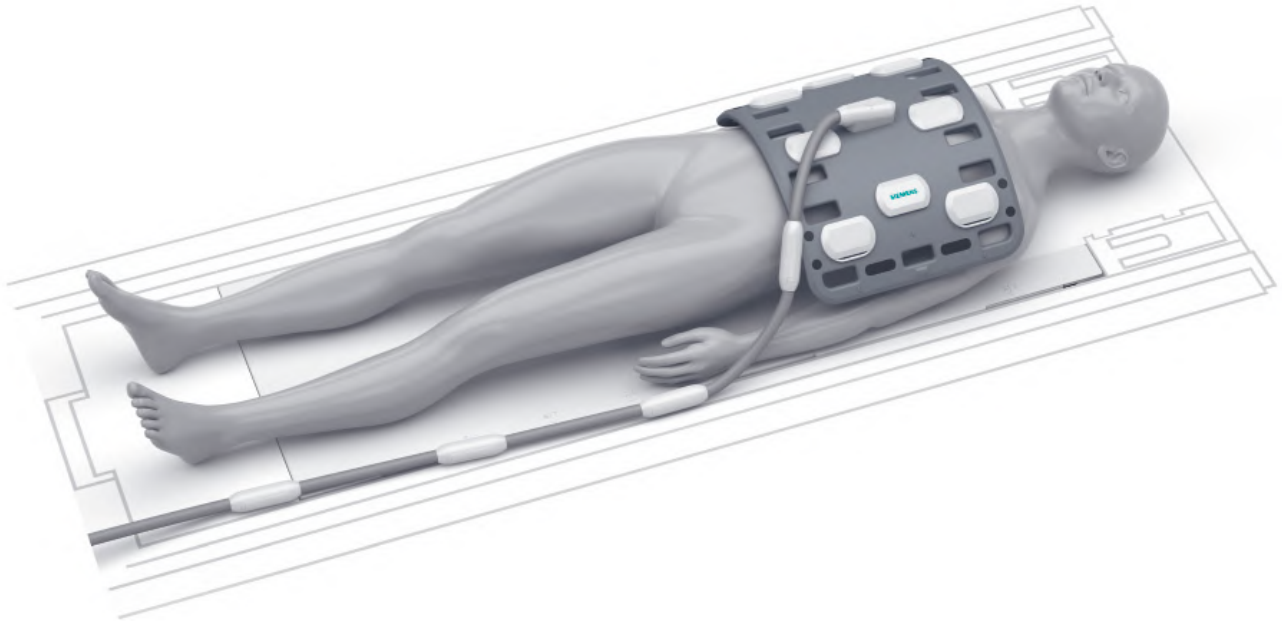

Weight

2 kg
"patient-felt" weight of coil only 1.1 kg

Dimensions (L x W x H)

385 mm x 590 mm x 65 mm

Cable length

168 cm (70 cm longer compared to the Body 18)

¹⁾ Prerequisite: Tim [204x48]

Siemens Healthcare Headquarters

Siemens Healthcare GmbH
Henkestr. 127
91052 Erlangen
Germany
Telephone: +49 9131 84-0
[siemens.com/healthcare](https://www.siemens.com/healthcare)

Legal Manufacturer

Siemens Healthcare GmbH
Henkestr. 127
91052 Erlangen
Germany

Order No. A91MR-500E-A106-7600G | Printed in Germany | MC.MR-00500 PA 0416 POD | © Siemens Healthcare GmbH, 2016

[siemens.com/healthcare](https://www.siemens.com/healthcare)

siemens.com/avanto-fit

MAGNETOM Avanto^{fit}

Body 30¹⁾

General

- Coil designed with 30 elements
- Pads for comfortable patient positioning at different positions on the table
- No coil tuning
- iPAT-compatible in all directions
- Dual-Density Signal Transfer enables ultra-high density coil design by integrating key RF components into the local coil
- SlideConnect technology for easy coil set up
- Flexible viscose material allows for easy positioning

Applications

- Thorax
- Abdomen
- Pelvis
- Hip

Typically combined with

- Head/Neck 20
- Spine 32
- Peripheral Angio 36 (optional)

¹⁾ Prerequisite: Tim[204x48]

Body 30¹⁾

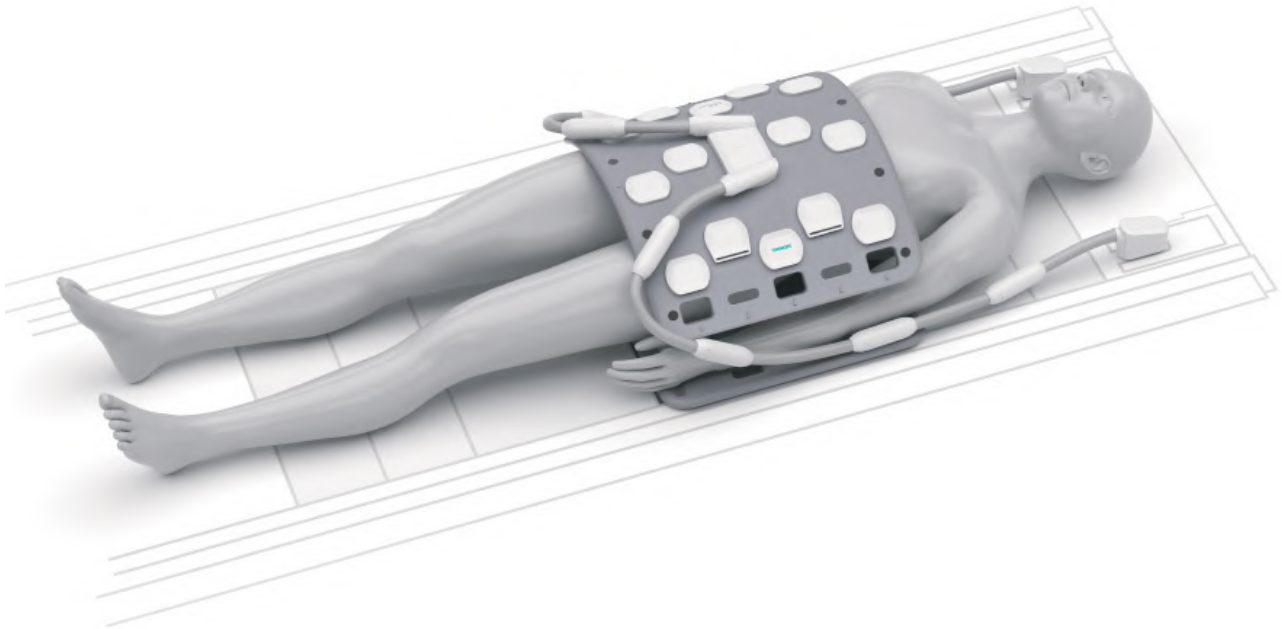

Weight

3 kg

"patient-felt" weight of coil only 1.6 kg

Dimensions (L x W x H)

460 mm x 600 mm x 55 mm

¹⁾ Prerequisite: Tim[204x48]

Siemens Healthcare Headquarters

Siemens Healthcare GmbH
Henkestr. 127
91052 Erlangen
Germany
Telephone: +49 9131 84-0
siemens.com/healthcare

Legal Manufacturer

Siemens Healthcare GmbH
Henkestr. 127
91052 Erlangen
Germany

Order No. A91MR-500E-A107-7600G | Printed in Germany | MC.MR-00500 PA 0416 POD | © Siemens Healthcare GmbH, 2016

siemens.com/healthcare

siemens.com/avanto-fit

MAGNETOM Avanto^{fit}

Flex Large 4
Flex Small 4

General

The Flex Large 4 and Flex Small 4 are part of the standard system configuration.

- Four integrated low-noise preamplifiers
- Allows flexible coil positioning
- Only one interface necessary for all Flex coils
- Several Flex Coil Interfaces can be used simultaneously
- Connection via Flex Coil Interface 1.5T

Features

- Wrap-around coil made from soft and flexible material
- 4-channel design
- iPAT-compatible
- No coil tuning

Flex Large 4

Applications

Imaging of large regions such as medium to large shoulder, hip, and knee

Typically combined with

- Head/Neck 20
- Body 18
- Peripheral Angio 36 (optional)
- Flex Small 4¹⁾
- Loop 1.5T coils¹⁾
- Endorectal coil¹⁾ (optional)

Flex Small 4

Imaging of small regions such as small to medium shoulder, wrist, elbow, and ankle

- Head/Neck 20
- Body 18
- Peripheral Angio 36 (optional)
- Flex Large 4¹⁾
- Loop 1.5T coils¹⁾
- Endorectal coil¹⁾ (optional)

¹⁾ Second Flex Coil Interface 1.5T required (option)

Flex Large 4 and Flex Small 4

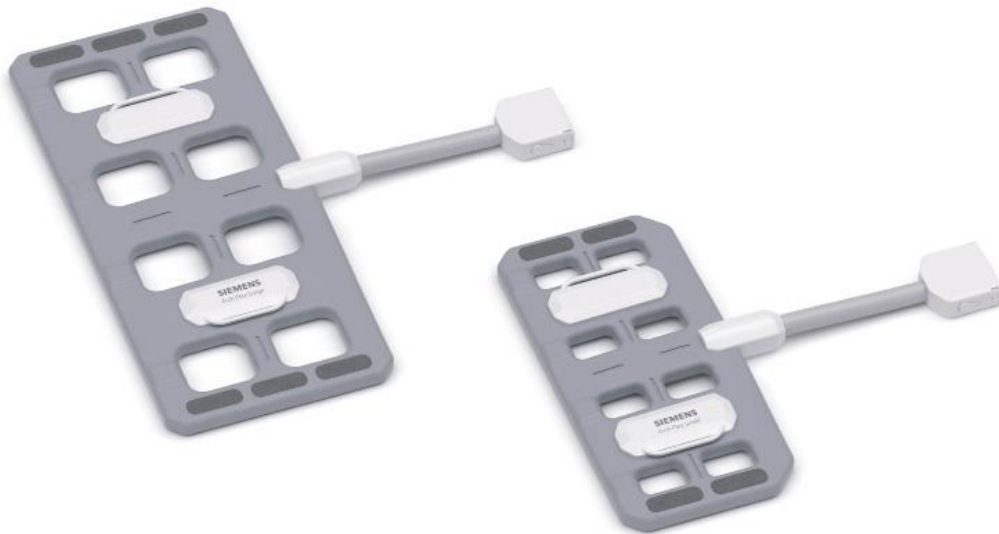

Weight	
Flex Large 4	FlexSmall 4
550 g	450 g

Dimensions (L x W x H)	
Flex Large 4	FlexSmall 4
516 mm x 224 mm	366 mm x 174 mm

Siemens Healthcare Headquarters
Siemens Healthcare GmbH
Henkestr. 127
91052 Erlangen
Germany
Telephone: +49 9131 84-0
siemens.com/healthcare

Legal Manufacturer
Siemens Healthcare GmbH
Henkestr. 127
91052 Erlangen
Germany

Order No. A91MR-500E-A108-7600G | Printed in Germany | MC.MR-00500 PA 0416 POD | © Siemens Healthcare GmbH, 2016

siemens.com/healthcare

siemens.com/avanto-fit

MAGNETOM Avanto^{fit}

Peripheral Angio 36

General

- 36-channel design with 36 integrated preamplifiers, distributed over 6 planes with 6 elements each
- Operates in an integrated fashion with Body 18 coils and with the Spine 32 and for whole-body examinations also with the Head/Neck 20
- Can be utilized head and feet first
- Both legs are independently covered with coil elements, maximizing the coil filling factor and the signal-to-noise ratio
- No coil tuning
- iPAT-compatible in all directions
- Dual-Density Signal Transfer enables ultra-high density coil designs by integrating key RF components into the local coil
- SlideConnect technology for easy coil set up
- One cable only for easy handling

Applications

- High resolution angiography of both legs with highest signal-to-noise ratio
- Bilateral examinations of long bones of the legs

Typically combined with

- Head/Neck 20
- Body 18
- Spine 32
- Flex Large 4
- Flex Small 4

Peripheral Angio 36

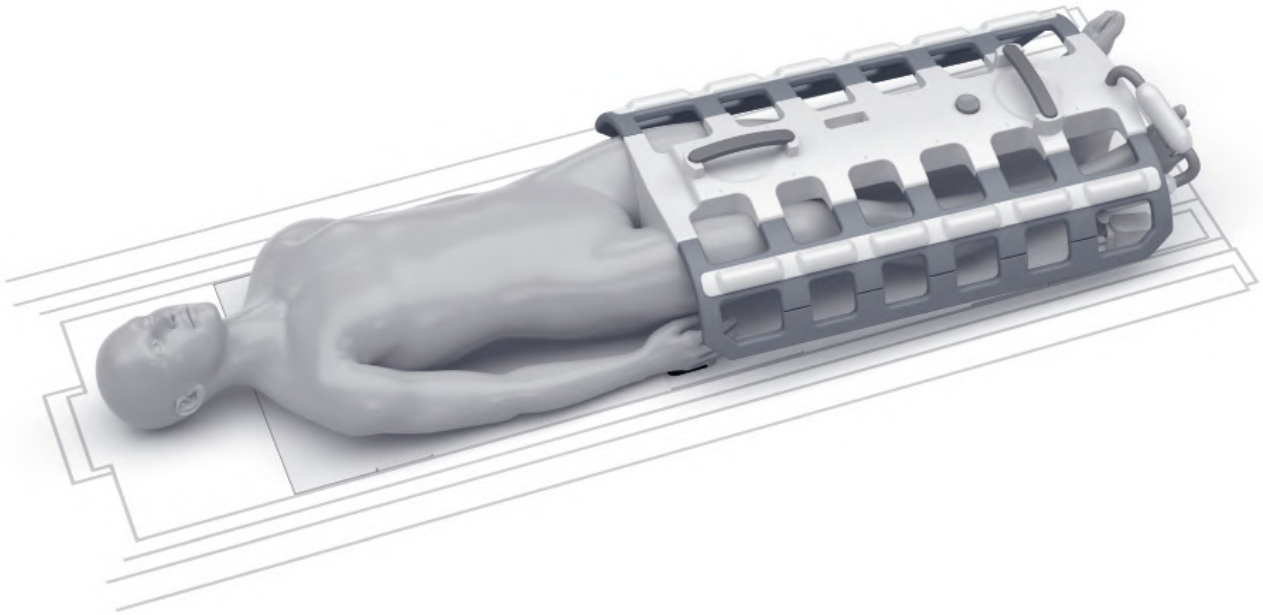

Weight

8 kg

Dimensions (L x W x H)

860 mm x 300–640 mm x 280 mm

Siemens Healthcare Headquarters

Siemens Healthcare GmbH
Henkestr. 127
91052 Erlangen
Germany
Telephone: +49 9131 84-0
siemens.com/healthcare

Legal Manufacturer

Siemens Healthcare GmbH
Henkestr. 127
91052 Erlangen
Germany

Order No. A91MR-500E-A109-7600G | Printed in Germany | MC.MR-00500 PA 0416 POD | © Siemens Healthcare GmbH, 2016

siemens.com/healthcare

MAGNETOM Avanto^{fit}

Loop Coils

Loop Coils

General

- No coil tuning
- iPAT-compatible in combination with other coils

Typically combined with

- Head/Neck 16/
- Head/Neck 20
- Body 18
- Spine 32
- All flexible coils¹⁾

Loop Coil, large

Application

Examination of upper or lower extremities (e.g. shoulder, axilla)

Loop Coil, medium

Application

Examination of inner ear, structure of wrist and fingers, pediatrics examinations²⁾

Loop Coil, small

Application

Examination of small structures near the surface (e.g. joints of fingers and toes, wrist, skin, temporomandibular joints (TMJ))

4-Channel FLEX Coil Interface

General

- 4 integrated low-noise preamplifiers
- Allows flexible coil positioning
- Only one interface necessary for all Loop coils
- Several Flex Coil Interfaces can be used simultaneously
- Flex Coil Interface 1.5T needed to connect coil with scanner (optional)
- Dual-Density Signal Transfer enables ultra-high density coil designs by integrating key RF components into the local coil

¹⁾ Second Flex Coil Interface required

²⁾ MR scanning has not been established as safe for imaging fetuses and infants under two years of age. The responsible physician must evaluate the benefit of the MRI examination in comparison to other imaging procedures.

Loop Coils



Loop Coil, large

Weight	Diameter
225 g	110 mm

Loop Coil, medium

Weight	Diameter
200 g	70 mm

Loop Coil, small

Weight	Diameter
175 g	40 mm

Siemens Healthcare Headquarters

Siemens Healthcare GmbH
Henkestr. 127
91052 Erlangen
Germany
Telephone: +49 9131 84-0
siemens.com/healthcare

Legal Manufacturer

Siemens Healthcare GmbH
Henkestr. 127
91052 Erlangen
Germany

[siemens.com/avanto-fit](https://www.siemens.com/avanto-fit)

MAGNETOM Avanto^{fit}

Hand/Wrist 16

General

- 16-channel coil with 16 integrated preamplifiers
- iPAT-compatible in all directions
- Hinged design of the upper part for quick and easy patient positioning
- Stabilization pads for comfortable positioning
- Holder allows off-center positioning to ensure a comfortable position for the patient
- No coil tuning
- Dual-Density Signal Transfer enables ultra-high density coil designs by integrating key RF components into the local coil
- SlideConnect technology for easy coil set up

Applications

High resolution hand and wrist imaging

Typically combined with

- Body 18
- Flex Large 4
- Flex Small 4
- Loop 1.5T coils (optional)

Hand/Wrist 16



Weight

Coil	approx. 2.8 kg
Base plate	approx. 1.6 kg

Dimensions (L x W x H)

Coil	approx. 332 mm x 215 mm x 115 mm
Base plate	approx. 524 mm x 313 mm x 30.5 mm

Siemens Healthcare Headquarters

Siemens Healthcare GmbH
Henkestr. 127
91052 Erlangen
Germany
Telephone: +49 9131 84-0
siemens.com/healthcare

Legal Manufacturer

Siemens Shenzhen Magnetic Resonance Ltd.
Siemens MRI Center, Gaoxin C. Ave. 2nd,
Hi-Tech Industrial Park
518057 Shenzhen
China

[siemens.com/avanto-fit](https://www.siemens.com/avanto-fit)

MAGNETOM Avanto^{fit}

Foot/Ankle 16

General

- 16-channel coil with 16 integrated preamplifiers
- iPAT-compatible in all directions
- Boot-like coil design
- Cable-less coil with DirectConnect™ technology
- Stabilization pads for comfortable patient positioning

General (Continued)

- No coil tuning
- Dual-Density Signal Transfer enables ultra-high density coil designs by integrating key RF components into the local coil

Applications

High resolution foot and ankle imaging

Foot/Ankle 16



Weight	
Coil	3.2 kg
Base plate	7.1 kg

Dimensions (L x W x H)	
Coil	410 mm x 330 mm x 390 mm
Base plate	427 mm x 333 mm x 383 mm

Siemens Healthcare Headquarters
Siemens Healthcare GmbH
Henkestr. 127
91052 Erlangen
Germany
Telephone: +49 9131 84-0
siemens.com/healthcare

Legal Manufacturer
Siemens Shenzhen Magnetic Resonance Ltd.
Siemens MRI Center, Gaoxin C. Ave. 2nd,
Hi-Tech Industrial Park
518057 Shenzhen
China

[siemens.com/avanto-fit](https://www.siemens.com/avanto-fit)

MAGNETOM Avanto^{fit}

Shoulder Large 16
Shoulder Small 16

General

- Two 16-channel coils to cover small and large shoulder anatomy, – each with 16-channel coil design with 16 integrated preamplifiers
- For narrow or wide shoulders the coil can be attached at different positions on the base plate
- Includes one base plate pad for high patient comfort
- No coil tuning
- iPAT-compatible in all directions

General (Continued)

- Dual-Density Signal Transfer enables ultra-high density coil designs by integrating key RF components into the local coil
- SlideConnect technology for easy coil set up

Applications

- Best visualization of small anatomical structures (e.g. labrum)
- Higher SNR and better field homogeneity
- Reduced slice thickness and measurement times

Shoulder Large and Shoulder Small 16

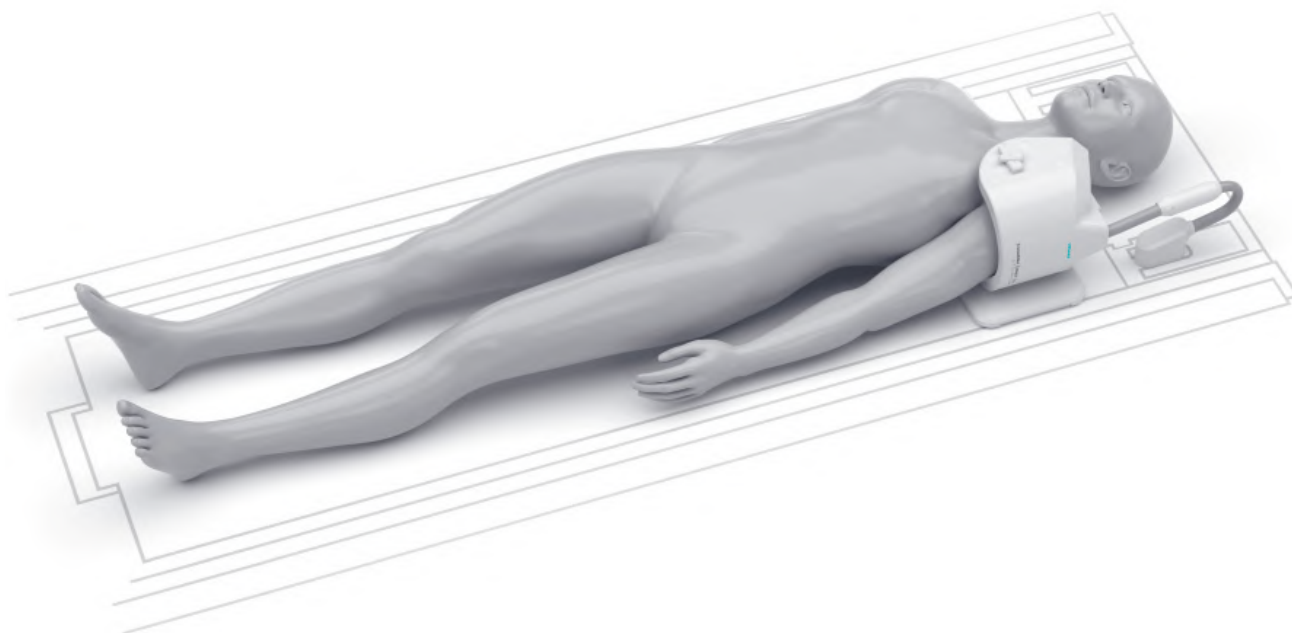

Technical Data

Shoulder Large 16	Opening	200 mm
	Weight	2.3 kg
Shoulder Small 16	Opening	165 mm
	Weight	2.2 kg

Technical Data (Continued)

Base plate	Dimensions (L x W)	445 mm x 490 mm
	Weight	5 kg

Siemens Healthcare Headquarters

Siemens Healthcare GmbH
Henkestr. 127
91052 Erlangen
Germany
Telephone: +49 9131 84-0
siemens.com/healthcare

Legal Manufacturer

Siemens Shenzhen Magnetic Resonance Ltd.
Siemens MRI Center, Gaoxin C. Ave. 2nd,
Hi-Tech Industrial Park
518057 Shenzhen
China

[siemens.com/avanto-fit](https://www.siemens.com/avanto-fit)

MAGNETOM Avanto^{fit}

CP Extremity Coil

General

- Transmit/receive coil
- Upper coil part removable
- Holder allows off-center positioning to keep knee or foot which is not under examination in a comfortable position
- No coil tuning
- Connection via Tim Coil Interface 1.5T

Applications

- Knee
- Ankle
- Peripheral MR Angiography
- Pediatric imaging¹⁾

¹⁾ MR scanning has not been established as safe for imaging fetuses and infants under two years of age. The responsible physician must evaluate the benefit of the MRI examination in comparison to other imaging procedures.

CP Extremity Coil



Weight

6.5 kg

Dimensions (L x W x H)

405 mm x 270 mm x 290 mm

Minimum inner dimension

190 mm

Siemens Healthcare Headquarters

Siemens Healthcare GmbH
Henkestr. 127
91052 Erlangen
Germany
Telephone: +49 9131 84-0
siemens.com/healthcare

Legal Manufacturer

Siemens Healthcare GmbH
Henkestr. 127
91052 Erlangen
Germany

[siemens.com/avanto-fit](https://www.siemens.com/avanto-fit)

MAGNETOM Avanto^{fit}

Tx/Rx 15-Channel Knee Coil¹⁾

General

- 15-channel transmit/receive coil
- 15-channel coil with 15 integrated preamplifiers, elements arranged in 3 rungs by 5 elements
- iPAT-compatible in all directions
- Upper coil part removable
- Holder allows off-center positioning to ensure a comfortable position for the patient
- Cushions for patient comfort and stabilization of the anatomy

General (Continued)

- No coil tuning
- One plug only
- SlideConnect technology for easy coil set up

Applications

- Examinations of joints in the area of the lower extremities
- High resolution knee imaging

¹⁾ Alternative name: Tx/Rx Knee 15

Tx/Rx 15-Channel Knee Coil



Weight

6.6 kg

Dimensions (L x W x H)

256 mm x 360 mm x 310 mm

Minimum inner dimension

154 mm

Siemens Healthcare Headquarters

Siemens Healthcare GmbH
Henkestr. 127
91052 Erlangen
Germany
Telephone: +49 9131 84-0
siemens.com/healthcare

Legal Manufacturer

Quality Electrodynamics LLC
700 Beta Drive, Suite 100
44143 Mayfield Village
USA
Phone: +1 440-484-2228

[siemens.com/avanto-fit](https://www.siemens.com/avanto-fit)

MAGNETOM Avanto^{fit}

Tx/Rx CP Head Coil

General

- CP Send/Receive head coil with integrated preamplifier
- Upper coil part removable
- Open patient-friendly design
- No coil tuning
- Cushions for patient comfort and stabilization of the head

General (Continued)

- Detachable mirror
- SlideConnect technology for easy coil set up

Applications

- Head examinations
- High resolution brain spectroscopy

Tx/Rx CP Head Coil

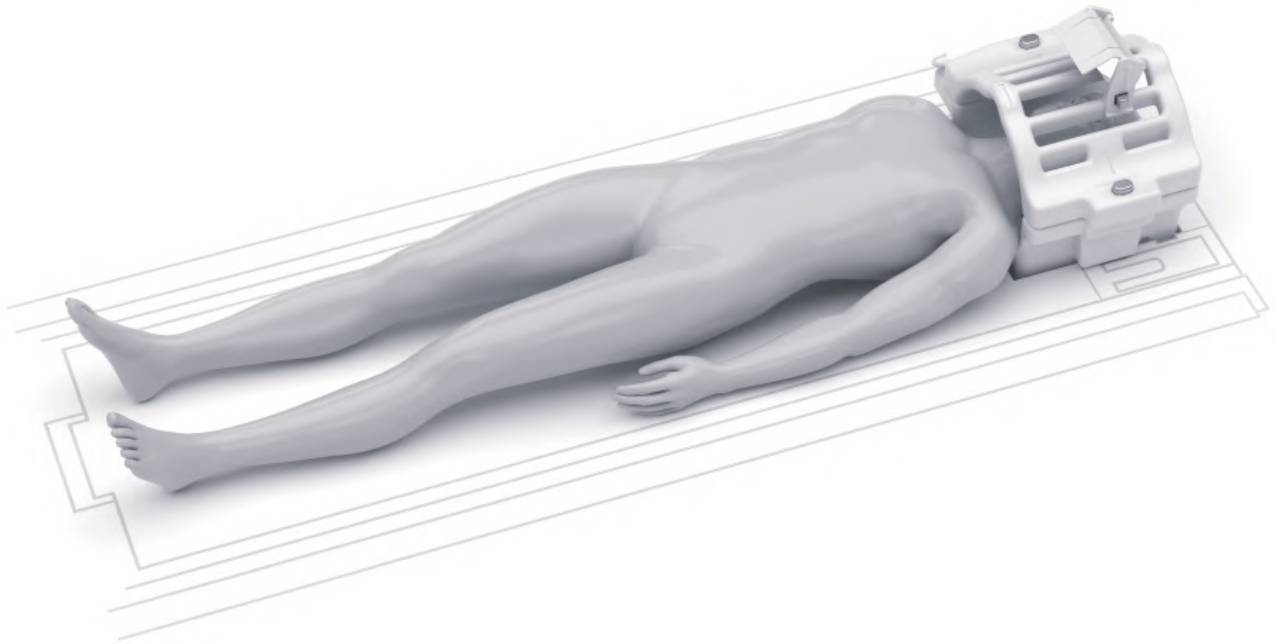

Weight

5.2 kg

Dimensions (L x W x H)

315 mm x 475 mm x 360 mm

Siemens Healthcare Headquarters

Siemens Healthcare GmbH
Henkestr. 127
91052 Erlangen
Germany
Telephone: +49 9131 84-0
siemens.com/healthcare

Legal Manufacturer

Quality Electrodynamics LLC
700 Beta Drive, Suite 100
44143 Mayfield Village
USA
Phone: +1 440-484-2228

Order No. A91MR-500E-A116-7600G | Printed in Germany | MC.MR-00500 PA 0416 POD | © Siemens Healthcare GmbH, 2016

siemens.com/healthcare

[siemens.com/avanto-fit](https://www.siemens.com/avanto-fit)

MAGNETOM Avanto^{fit}

4-Channel BI Breast Coil

General

- Frame
- 2-channel insert plate coil
- 2-channel patient pad coil
- Positioning cushion
- Head rest
- Biopsy plate
- Biopsy set: biopsy box; 2 fixation units (grid and post/pillar); positioning system including 2 needle adapter tubes and oil marker
- Tim Coil Interface 1.5T needed to connect coil with scanner
- Spine 32 coil can remain on the table

Applications

- Simultaneous basic imaging of both breasts in all directions
- Biopsy imaging for lateral, medial, and cranio-caudal access

Typically combined with

- Body 18

4-Channel BI Breast Coil

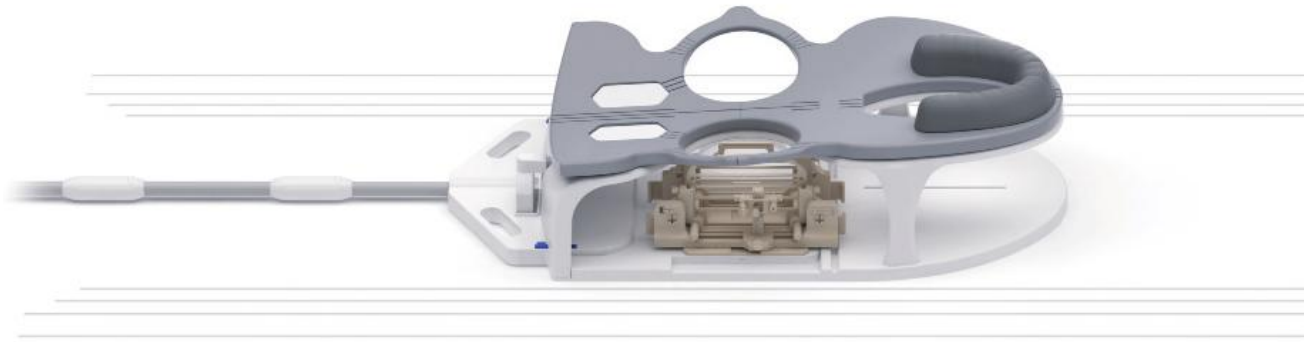

Weight (Coil and frame)

10 kg

Dimensions (L x W x H)

880 mm x 470 mm x 210 mm

Siemens Healthcare Headquarters

Siemens Healthcare GmbH
Henkestr. 127
91052 Erlangen
Germany
Telephone: +49 9131 84-0
siemens.com/healthcare

Legal Manufacturer

Noras MRI products GmbH
Leibnizstr. 4
97204 Höchberg
Germany
Phone: +49 931/29 92 7-0
Fax: +49 931/29 92 7-20
www.noras.de

Order No. A91MR-500E-A117-7600G | Printed in Germany | MC.MR-00500 PA 0416 POD | © Siemens Healthcare GmbH, 2016

siemens.com/healthcare

[siemens.com/avanto-fit](https://www.siemens.com/avanto-fit)

MAGNETOM Avanto^{fit}

16-Channel AI Breast Coil

General

- The coil consists of a 16-channel design with 16 integrated preamplifiers. The coil elements are arranged in arrays of 6 elements, plus an axilla element and a cup design element on each side.
- Frame
- Positioning cushion
- Head rest
- iPAT compatible in all directions

General (Continued)

- Two Tim Coil Interfaces 1.5T needed to connect coil with scanner (one optional)
- Spine 32 can remain on the table

Applications

- Simultaneous imaging of both breasts in all directions
- High-resolution 2D and 3D MR breast imaging

Typically combined with

- Body 18 Long (optional)

16-Channel AI Breast Coil

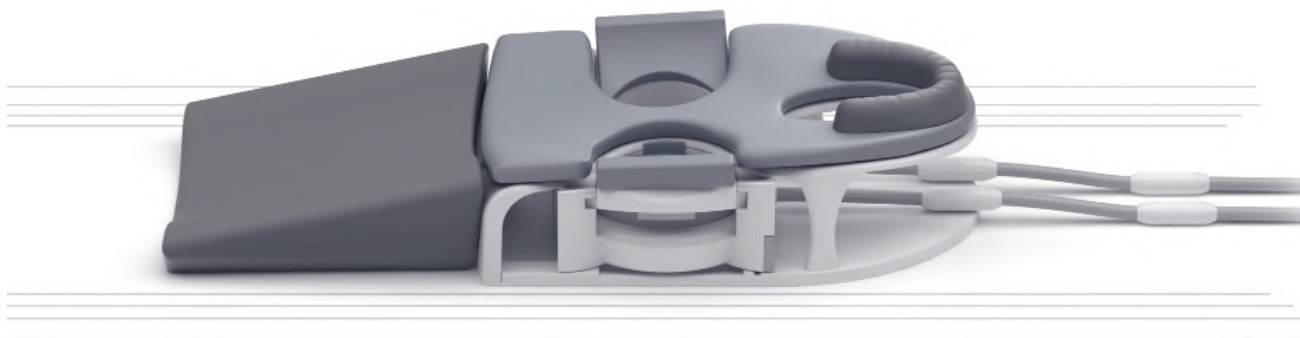

Weight

11 kg

Dimensions (L x W x H)

710 mm x 470 mm x 200 mm

Siemens Healthcare Headquarters

Siemens Healthcare GmbH
Henkestr. 127
91052 Erlangen
Germany
Telephone: +49 9131 84-0
siemens.com/healthcare

Legal Manufacturer

RAPID Biomedical GmbH
Technology Park Würzburg-Rimpar
Kettelerstrasse 3-11
97222 Rimpar
Germany
Phone: +49 93 65 / 88 26-0
Fax: +49 93 65 / 88 26-99
www.rapidbiomed.de

Order No. A91MR-500E-A118-7600G | Printed in Germany | MC.MR-00500 PA 0416 POD | © Siemens Healthcare GmbH, 2016

siemens.com/healthcare

siemens.com/avanto-fit

MAGNETOM Avanto^{fit}

2-/4-/8-Channel Sentinelle Breast Coil

General

- Patient frame
- Immobilization plate
- Slider
- Two 3-channel diagnostic insert coils, two 1-channel biopsy insert coils, one 2-channel medial coil
- The coil can be used in the following configurations:
 - 8-channel diagnostic imaging,
 - 4-channel biopsy (bilateral / lateral),
 - 2-channel biopsy (unilateral / medial)
- Breast cushion set
- Height adjustable head rest
- Contra-lateral support plate for use in unilateral biopsy
- Tim Coil Interface 1.5T needed to connect coil with scanner
- Biopsy set for training purposes (grid, marker and training needle kit)
- iPAT compatible in all directions

Applications

- Simultaneous imaging of both breasts in all directions
- Biopsy imaging for lateral and medial access
- High-resolution 2D and 3D imaging
- For quantitative spectroscopy (GRACE¹⁾) a reference bottle can be inserted.

Typically combined with

- Body 18

¹⁾ Optional

2-/4-/8-Channel Sentinelle Breast Coil

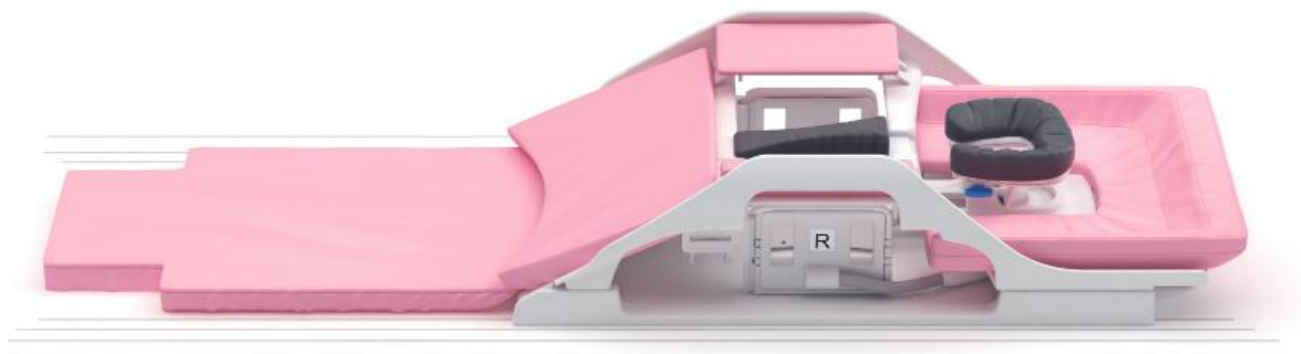

Weight

16 kg without riser
22 kg with riser

Dimensions (L x W x H)

1097 mm x 582 mm x 279 mm

Siemens Healthcare Headquarters

Siemens Healthcare GmbH
Henkestr. 127
91052 Erlangen
Germany
Telephone: +49 9131 84-0
siemens.com/healthcare

Legal Manufacturer

Invivo Corporation
3545 SW 47th Avenue
Gainesville, FL 32608
Phone: +1-352-336-0010
Phone: +1-877-468-4861
Fax: +1-352-264-3427
E-mail: info@invivocorp.com

Order No. A91MR-500E-A119-7600G | Printed in Germany | MC.MR-00500 PA 0416 POD | © Siemens Healthcare GmbH, 2016

siemens.com/healthcare

siemens.com/avanto-fit

MAGNETOM Avanto^{fit}

8-Channel Sentinelle Breast Coil/ Upgrade to Biopsy Configuration

Sentinelle Breast Coil (Imaging Configuration)

General

- Patient frame
- Immobilization plate
- Slider
- Two 3-channel diagnostic insert coils, one 2-channel medial coil
- The coil can be used for 8-channel diagnostic imaging
- Breast cushion set
- Height adjustable head rest
- iPAT-compatible in all directions
- Tim Coil Interface 1.5T needed to connect coil with scanner
- Coil configuration functionally upgradable for biopsy (optional)

Applications

- Simultaneous imaging of both breasts in all directions
- High-resolution 2D and 3D imaging
- For quantitative spectroscopy (GRACE¹⁾) a reference bottle can be inserted.

Typically combined with

- Body 18

Sentinelle Breast Coil Upgrade to Biopsy Configuration²⁾

General

- Two 1-channel biopsy insert coils, one 2-channel medial coil
- The coil can be used in the following configurations: 4-channel biopsy (bilateral / lateral), 2-channel biopsy (unilateral / medial)
- Contra-lateral support plate for use in unilateral biopsy
- Biopsy set for training purposes (grid, marker and training needle kit)

Applications

Biopsy imaging for lateral and medial access

¹⁾ Optional

²⁾ Prerequisite: 8-Channel Imaging Configuration

8-Channel Sentinelle Breast Coil/ Upgrade to Biopsy Configuration

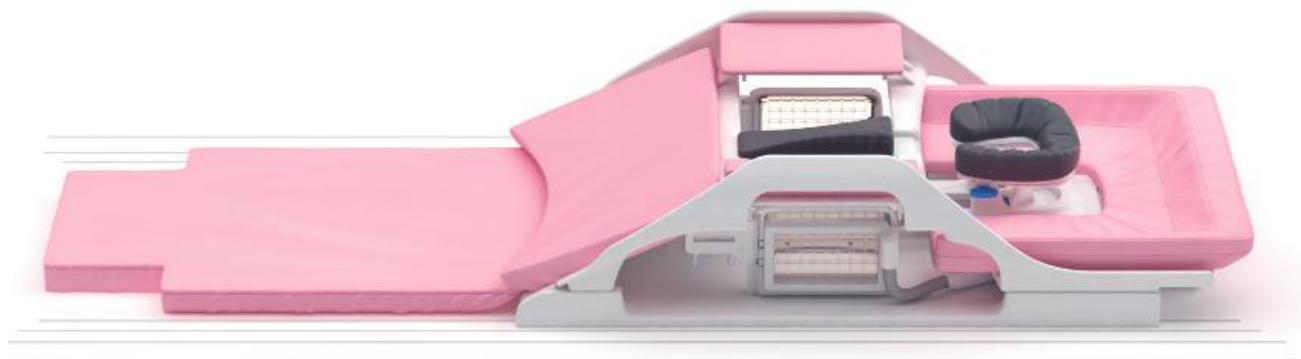

Sentinelle Breast Coil (Imaging Configuration)

Weight

16 kg without riser; 22 kg with riser

Dimensions (L x W x H)

1097 mm x 582 mm x 279 mm

Sentinelle Breast Coil Upgrade to Biopsy Configuration¹⁾

Weight

16 kg without riser; 22 kg with riser

Dimensions (L x W x H)

1097 mm x 582 mm x 279 mm

¹⁾ Prerequisite: 8-Channel Imaging Configuration

Siemens Healthcare Headquarters

Siemens Healthcare GmbH
Henkestr. 127
91052 Erlangen
Germany
Telephone: +49 9131 84-0
siemens.com/healthcare

Legal Manufacturer

Invivo Corporation
3545 SW 47th Avenue
Gainesville, FL 32608
Phone: +1-352-336-0010
Phone: +1-877-468-4861
Fax: +1-352-264-3427
E-mail: info@invivocorp.com

Order No. A91MR-500E-A120-7600G | Printed in Germany | MC.MR-00500 PA 0416 POD | © Siemens Healthcare GmbH, 2016

siemens.com/healthcare

siemens.com/avanto-fit

MAGNETOM Avanto^{fit}

2-/10-/16-Channel Sentinelle Breast Coil

General

- Patient frame
- Immobilization plate
- Slider
- Two 4-channel diagnostic insert coils, two 1-channel biopsy insert coils, one 8-channel medial coil
- The coil can be used in the following configurations:
 - 16-channel diagnostic imaging,
 - 10-channel biopsy (bilateral/lateral),
 - 2-channel biopsy (unilateral/medial)
- Breast cushion set
- Height adjustable head rest
- Contra-lateral support plate for use in unilateral biopsy
- Biopsy set for training purposes (grid, marker and training needle kit)
- iPAT-compatible in all directions
- Two Tim Coil Interfaces 1.5T needed to connect coil with scanner (one optional)

Applications¹⁾

- Simultaneous imaging of both breasts in all directions
- Biopsy imaging for lateral and medial access
- High-resolution 2D and 3D imaging
- For quantitative spectroscopy (GRACE¹⁾) a reference bottle can be inserted.

Typically combined with

- Body 18 Long (optional)

¹⁾ Optional

2-/10-/16-Channel Sentinelle Breast Coil

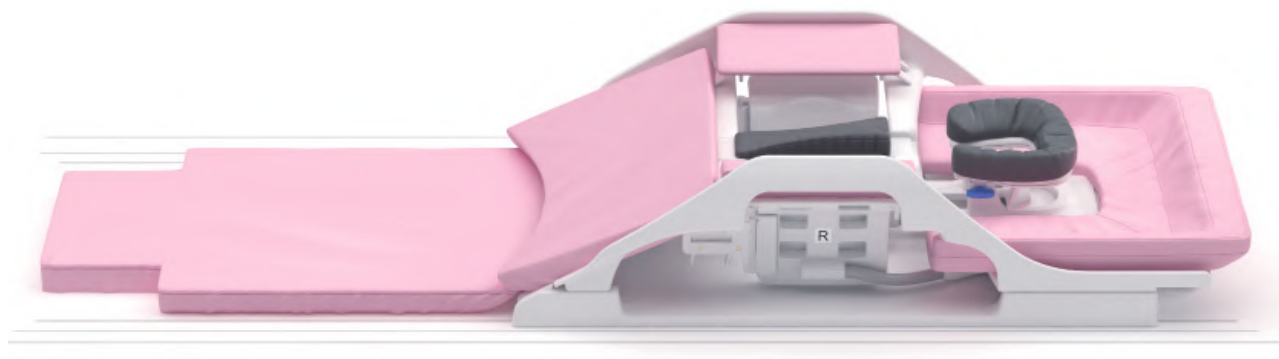

Weight

16 kg without riser; 22 kg with riser

Dimensions (L x W x H)

1097 mm x 582 mm x 279 mm

Siemens Healthcare Headquarters

Siemens Healthcare GmbH
Henkestr. 127
91052 Erlangen
Germany
Telephone: +49 9131 84-0
siemens.com/healthcare

Legal Manufacturer

Invivo Corporation
3545 SW 47th Avenue
Gainesville, FL 32608
Phone: +1-352-336-0010
Phone: +1-877-468-4861
Fax: +1-352-264-3427
E-mail: info@invivocorp.com

Order No. A91MR-500E-A121-7600G | Printed in Germany | MC.MR-00500 PA 0416 POD | © Siemens Healthcare GmbH, 2016

siemens.com/healthcare

siemens.com/avanto-fit

MAGNETOM Avanto^{fit}

16-Channel Sentinelle Breast Coil / Upgrade to Biopsy Configuration

16-Channel Sentinelle Breast Coil (Imaging Configuration)

General

- Patient frame
- Immobilization plate
- Slider
- Two 4-channel diagnostic insert coils, one 8-channel medial coil
- The coil can be used in the following configurations: 16-channel diagnostic imaging
- Breast cushion set
- iPAT-compatible in all directions
- Height adjustable head rest
- Connection with two Tim Coil Interfaces 1.5T (one optional)

Applications

- Simultaneous imaging of both breasts in all directions
- High-resolution 2D and 3D imaging
- For quantitative spectroscopy (GRACE¹⁾) a reference bottle can be inserted.

Typically combined with

- Body 18 Long (optional)

16-Channel Sentinelle Breast Coil / Upgrade to Biopsy Configuration²⁾

General

- Two 1-channel biopsy insert coils, one 8-channel medial coil
- The coil can be used in the following configurations: 10-channel biopsy (bilateral / lateral), 2-channel biopsy (unilateral / medial)
- Contra-lateral support plate for use in unilateral biopsy
- Biopsy set for training purposes (grid, marker and training needle kit)

Applications

Biopsy imaging for lateral and medial access

¹⁾ Optional

²⁾ Prerequisite: 16-Channel Imaging Configuration

16-Channel Sentinelle Breast Coil Upgrade to Biopsy Configuration

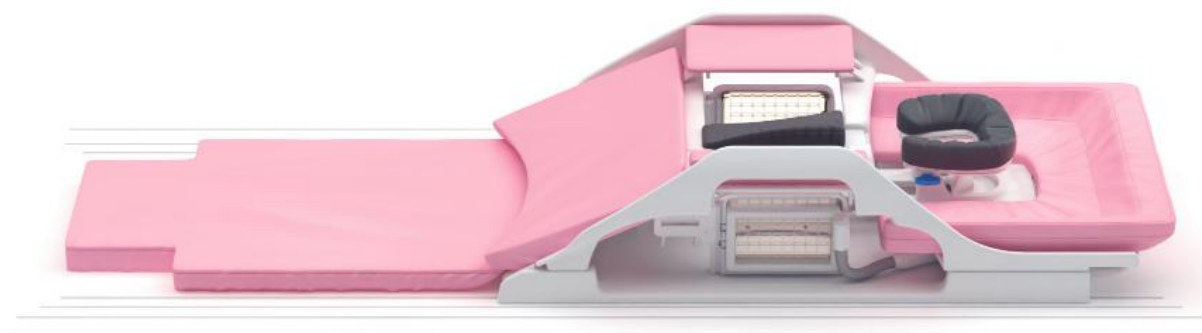

16-Channel Sentinelle Breast Coil (Imaging Configuration)

Weight

16 kg without riser; 22 kg with riser

Dimensions (L x W x H)

1097 mm x 582 mm x 279 mm

16-Channel Sentinelle Breast Coil / Upgrade to Biopsy Configuration¹⁾

Weight

16 kg without riser; 22 kg with riser

Dimensions (L x W x H)

1097 mm x 582 mm x 279 mm

¹⁾ Prerequisite: 16-Channel Imaging Configuration

Siemens Healthcare Headquarters

Siemens Healthcare GmbH
Henkestr. 127
91052 Erlangen
Germany
Telephone: +49 9131 84-0
siemens.com/healthcare

Legal Manufacturer

Invivo Corporation
3545 SW 47th Avenue
Gainesville, FL 32608
Phone: +1-352-336-0010
Phone: +1-877-468-4861
Fax: +1-352-264-3427
E-mail: info@invivocorp.com

Order No. A91MR-500E-A122-7600G | Printed in Germany | MC.MR-00500 PA 0416 POD | © Siemens Healthcare GmbH, 2016

siemens.com/healthcare

siemens.com/avanto-fit

MAGNETOM Avanto^{fit}

Breast 18

General

- 18-channel design with 4 frontal elements, 4 elements around the breast and 1 axillary element, for each side
- Height adjustable head rest
- Compact design
- Plug parking position
- Single plug connect
- iPAT-compatible in all directions
- Support cushion with mechanical lock to coil
- Volume per breast 2200 ml

Applications

- Simultaneous imaging of both breasts in all directions
- High-resolution 2D and 3D imaging
- For quantitative imaging spectroscopy (GRACE¹⁾) a reference bottle can be inserted

Typically combined with

- Body 18

¹⁾ Optional

Breast 18



Weight

5.5 kg

Dimensions (L x W x H)

575 mm x 410 mm x 205 mm

Siemens Healthcare Headquarters

Siemens Healthcare GmbH
Henkestr. 127
91052 Erlangen
Germany
Telephone: +49 9131 84-0
[siemens.com/healthcare](https://www.siemens.com/healthcare)

Legal Manufacturer

Siemens Healthcare GmbH
Henkestr. 127
91052 Erlangen
Germany

[siemens.com/avanto-fit](https://www.siemens.com/avanto-fit)

MAGNETOM Avanto^{fit}

Sentinelle Endorectal Coil¹⁾

General

- Reusable
- Improved coil handling (no inflation necessary)
- Reduced form factor (comparable to endorectal ultrasound probe) vs. conventional inflatable coil
- Reduced prostate deformation through smaller coil diameter
- 2 channels
- Parallel imaging capabilities
- Includes comfortable patient support that provides optimum access
- Held by stable, easily positioned arm (one-knob multi-axis fixation)

Applications

- Excellent visualization of the prostate, outstanding spectroscopy performance
- Non-invasive preoperative diagnostic evaluation and treatment planning

Typically combined with

- Body 18
- Spine 32

Technical Data

2 channels

¹⁾ Alternative name: Prostate 2

Sentinelle Endorectal Coil



Siemens Healthcare Headquarters

Siemens Healthcare GmbH
Henkestr. 127
91052 Erlangen
Germany
Telephone: +49 9131 84-0
siemens.com/healthcare

Legal Manufacturer

Invivo Corporation
3545 SW 47th Avenue
Gainesville, FL 32608
Phone: +1-352-336-0010
Phone: +1-877-468-4861
Fax: +1-352-264-3427
E-mail: info@invivocorp.com

Order No. A91MR-500E-A124-7600G | Printed in Germany | MC.MR-00500 PA 0416 POD | © Siemens Healthcare GmbH, 2016

siemens.com/healthcare

siemens.com/avanto-fit

MAGNETOM Avanto^{fit}

Endorectal Coil Kit

General

- The Endorectal Coil Kit includes the MEDRAD Endo Interface 1.5T* and the Endo Adapter for MEDRAD 1.5T, and connects to the Flex Coil Interface 1.5T that comes standard with the MAGNETOM Avanto^{fit}
- Interface device for connecting the disposable MEDRAD prostate, colon, or cervix receive coil* (to be ordered separately)
- No coil tuning

Applications

- Excellent visualization of the prostate, colon, rectum, and cervix
- Non-invasive preoperative diagnostic evaluation and treatment planning

Typically combined with

- Body 18
- Spine 32

* Legal Manufacturer:
Bayer Medical Care Inc.
1 Bayer Drive
Indianola, PA 15051-0780
U.S.A.
Phone: +1 412-767-2400
Fax: +1 416-594-9696
www.medrad.com

Endorectal Coil Kit

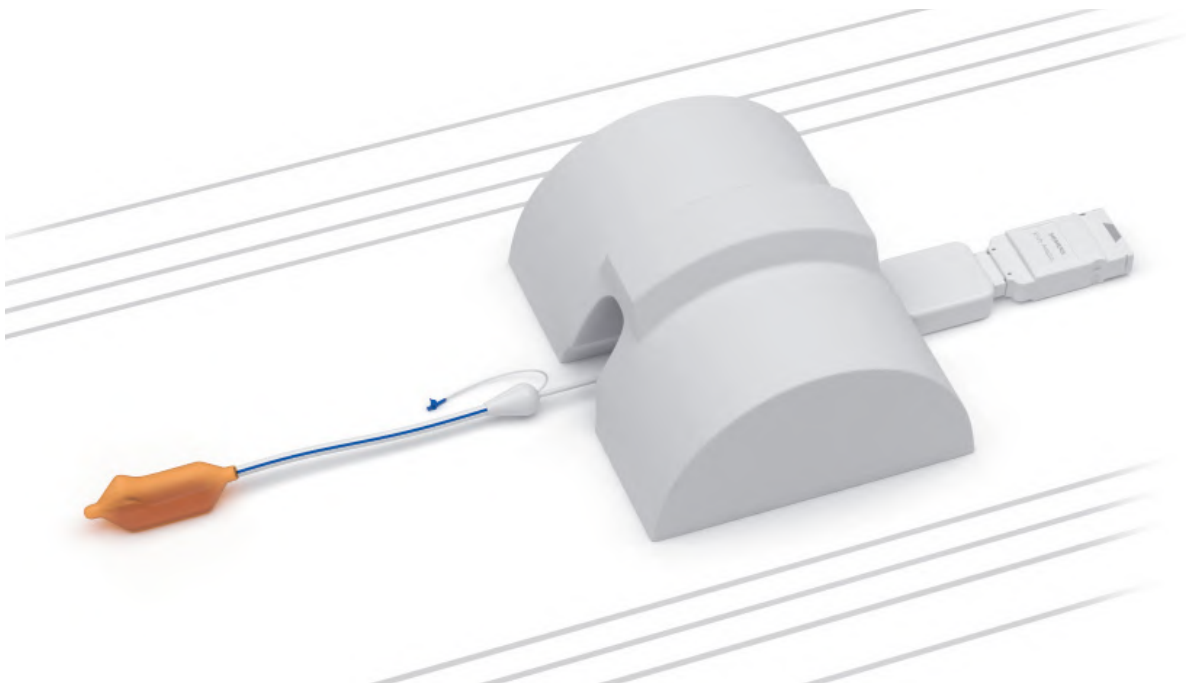

Weight of the disposable coil

200 g

Siemens Healthcare Headquarters

Siemens Healthcare GmbH
Henkestr. 127
91052 Erlangen
Germany
Telephone: +49 9131 84-0
siemens.com/healthcare

Legal Manufacturer

Siemens Healthcare GmbH
Henkestr. 127
91052 Erlangen
Germany

Order No. A91MR-500E-A125-7600G | Printed in Germany | MC.MR-00500 PA 0416 POD | © Siemens Healthcare GmbH, 2016

siemens.com/healthcare

siemens.com/avanto-fit

MAGNETOM Avanto^{fit}

Pediatric 16¹⁾

General

- 16-channel Head/Neck design with 16 integrated pre-amplifiers, with 13 elements for head imaging (a ring of 7 and a ring of 6 elements) and 3 elements for neck imaging
- Head and neck elements can be used separately for head-only and neck-only imaging
- Neck elements can be switched off when only scanning the brain
- Smooth integration into the table with the Spine coil
- Can be used in combination with other Tim 4G coils (e.g. Spine and Body) for whole body imaging
- Cable-less with DirectConnect™ technology
- Upper coil part easily removable
- Cushioned head stabilizers (removable)
- No coil tuning required
- iPAT compatible in all directions
- Dual-Density Signal Transfer technology with key RF components integrated into the coil

General (Continued)

- Comes with a cradle (optional for imaging) which can be used to safely and efficiently transport and position children up to 5 months of age and 10 kg in weight.
- Features a recess at the bottom of the anterior coil for easier, better positioning of intubation tubes
- 4 cm aperture at the top of the coil to ensure good ventilation

Applications

- For head and neck examinations of children up to 18 months of age
- Can be combined with other Tim 4G coils for whole body imaging

Typically combined with

- | | |
|----------------|----------------------------------|
| • Spine 32 | • Flex Small 4 |
| • Body 18 | • 4-Channel Special-Purpose Coil |
| • Flex Large 4 | |

¹⁾ MR scanning has not been established as safe for imaging fetuses and infants under two years of age. The responsible physician must evaluate the benefit of the MRI examination in comparison to other imaging procedures

Pediatric 16¹⁾

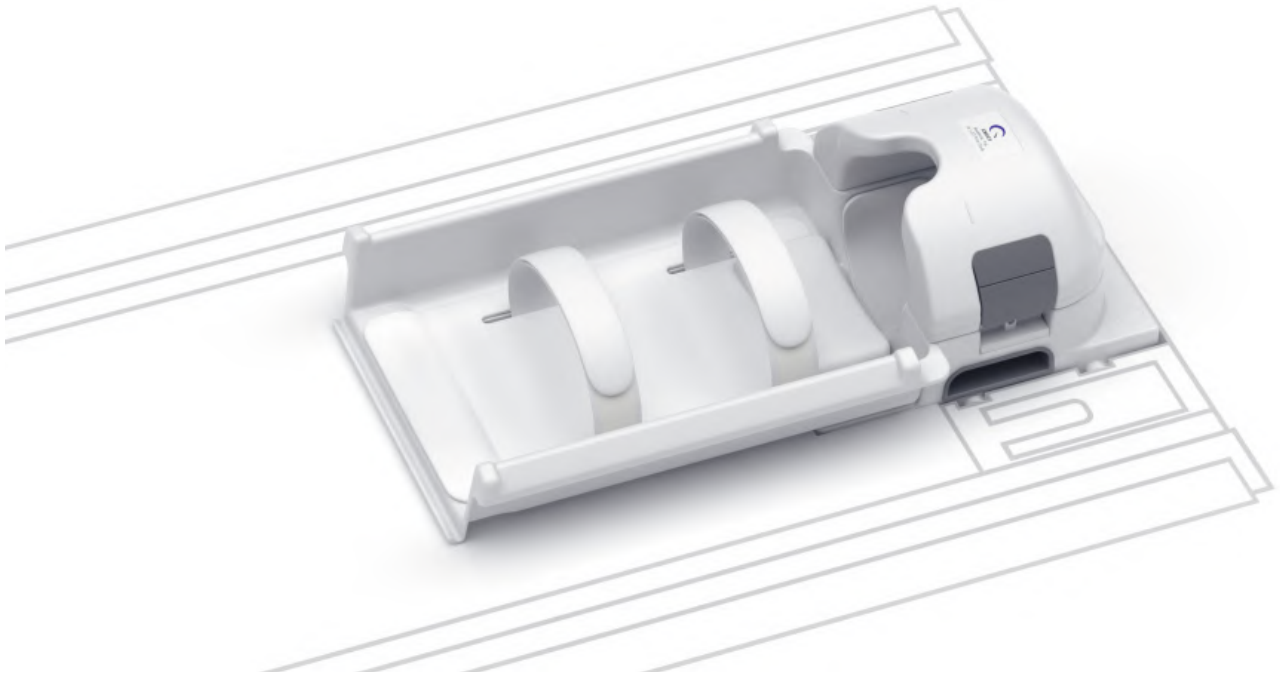

Weight	
Total Coil	4.4 kg
Anterior Coil	1.4 kg
Cradle	2.3 kg

Dimensions (L x W x H)	
Coil	371 mm x 318 mm x 269 mm
Cradle	685 mm x 319 mm x 123 mm

Siemens Healthcare Headquarters

Siemens Healthcare GmbH
Henkestr. 127
91052 Erlangen
Germany
Telephone: +49 9131 84-0
siemens.com/healthcare

Legal Manufacturer

Quality Electrodynamics LLC
700 Beta Drive, Suite 100
44143 Mayfield Village
USA
Phone: + 1 440-484-2228

SIEMENS

[siemens.com/avanto-fit](https://www.siemens.com/avanto-fit)

MAGNETOM Avanto^{fit}

4-Channel Special-Purpose Coil

General

- 4-channel
- iPAT compatible
- No coil tuning

Applications

- Carotids
- Examinations with small Field-of-Views
- Small structures near the surface

4-Channel Special-Purpose Coil

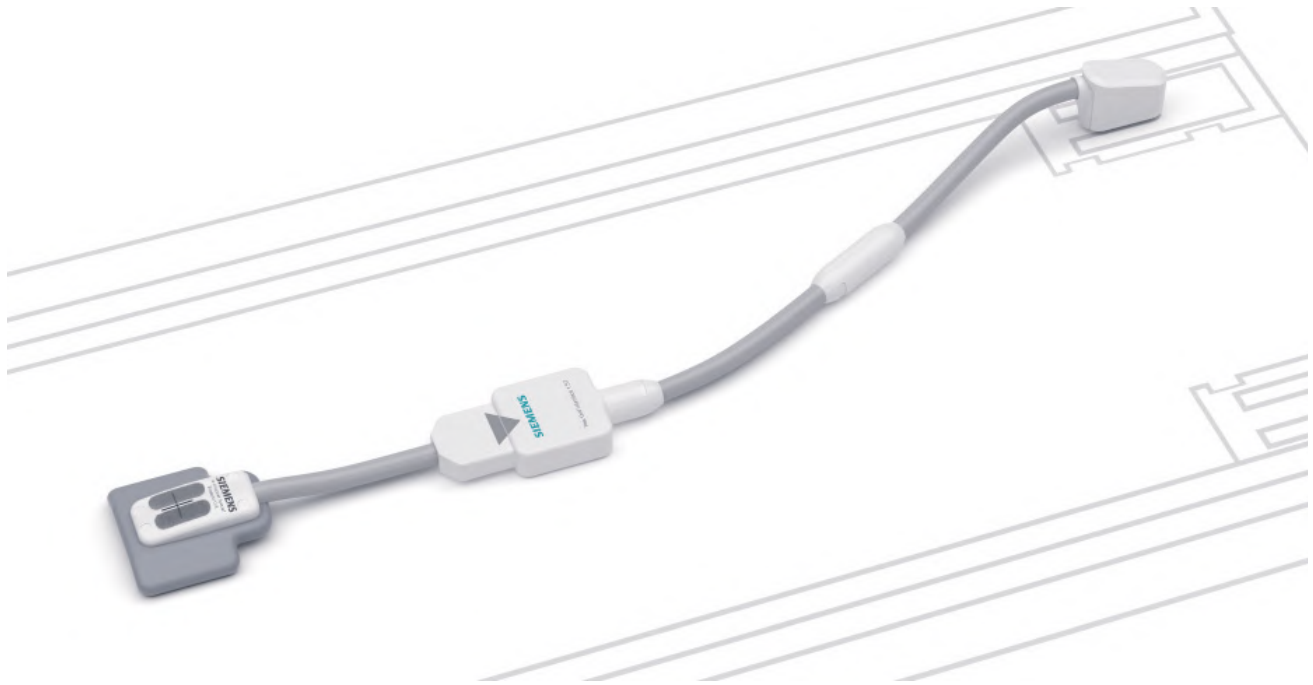

Weight

300 g

Dimensions (L x W x H)¹⁾

132 mm x 125 mm x 40 mm

¹⁾ without cable

Siemens Healthcare Headquarters

Siemens Healthcare GmbH
Henkestr. 127
91052 Erlangen
Germany
Telephone: +49 9131 84-0
siemens.com/healthcare

Legal Manufacturer

Siemens Shenzhen Magnetic Resonance Ltd.
Siemens MRI Center, Gaoxin C. Ave. 2nd,
Hi-Tech Industrial Park
518057 Shenzhen
China

SIEMENS



[siemens.com/avanto-fit](https://www.siemens.com/avanto-fit)

MAGNETOM Avanto^{fit}

Application Packages

Application Packages

Quiet Suite

Quiet Suite enables complete, quiet examinations of the brain and large joints. Quiet Suite includes QuietX, an algorithm which enables intelligent gradient optimization to substantially reduce noise without significant compromise to image quality or scan time.

In addition, Quiet Suite includes PETRA, a 3D T1-weighted sequence which is barely audible above background noise. When used with a Tx/Rx coil, PETRA is inaudible.

- Quiet prescan normalize and quiet localizers
- QuietX TSE, SE and GRE sequences for T1, T2, and DarkFluid contrasts
- QuietX SWI
- QuietX DWI¹⁾
- PETRA (Pointwise Encoding Time reduction with Radial Acquisition) for inaudible 3D T1-weighted imaging
- Optimized Quiet protocols for the brain, spine and large joints

FREEZEit

FREEZEit combines the two applications TWIST-VIBE and StarVIBE.

FREEZEit facilitates high quality diagnostic body MR imaging. Based on the excellent soft tissue contrast that MRI inherently offers, FREEZEit now adds imaging speed and motion compensation to body MRI and beyond. This allows i.e. imaging the entire arterial phase of the liver with multiple 3D datasets within seconds while maintaining a high spatial image resolution. Furthermore, the motion compensation of FREEZEit enables contrast-enhanced MR imaging during free breathing.

StarVIBE	StarVIBE is a motion insensitive VIBE sequence using a stack-of-stars trajectory. It allows abdominal, head, head neck, spinal, thoracic and pelvic imaging in free breathing mode, providing a solution for patients without breathhold capabilities.
----------	--

TWIST-VIBE	TWIST-VIBE is a fast, high-resolution 4D imaging sequence for e.g. multi-arterial liver imaging and for thoracic, abdominal and pelvic application. It is a VIBE sequence with CAIPIRINHA capability providing high spatial resolution. The view-sharing mode provides temporal information to ensure the right contrast timing for different lesions. Dixon is used for fat-water separation.
------------	--

LiverLab²⁾

Within the Abdomen Dot Engine, LiverLab is a system guided workflow to examine the hepatic fat and iron status. The Inline First Look Dixon sequence gives the user a first overview of possible fat and/or iron overload in the whole liver. Based on the resulting images, liver segmentation runs without user interaction. If further evaluation is needed, the user can choose from two methods: HISTO is a push-button single-breathhold single-voxel spectroscopy method to calculate fat signal fraction as well as water R2; Multi-echo Dixon VIBE is an image based method to calculate maps such as water, fat, fat signal fraction, and R2*.

¹⁾ Prerequisite: Advanced Diffusion Package

²⁾ Prerequisite: Abdomen Dot Engine (optional)

Advanced WARP¹⁾

Advanced WARP enables the reduction of gross metal artifacts (i.e. through-plane artifacts) caused by large orthopedic implants. It contains the 2D TSE based SEMAC technique and is especially useful in the case of hip and knee joint replacements. Available protocols include T1-weighted, T2-weighted, proton density and STIR contrast.

Tim Planning Suite

Easy planning of extended Field of View examinations in an efficient way using Set-n-Go protocols. It allows planning of several stations at once e.g. on composed localizer images. The overlap of slice groups can be adjusted. All stations can have independent parameter settings although they are displayed together. A special coupling mode allows easy positioning of all stations at once according to the patient's anatomy. Fully supports scan@center and Phoenix functionality.

- Tim Planning UI with optimized layout for slice positioning
- Ready to use Set-n-Go protocols for different clinical questions
- Integrated toolbar for fast advanced slice planning: FoV-Plus, FoV-Minus, AlignParallel, AlignFieldOfViews

RESOLVE

RESOLVE (Readout Segmentation Of Long Variable Echo-trains) delivers high resolution diffusion-weighted imaging (DWI) for visualizing the diffusion properties of fine anatomical structures, enabling accurate lesion evaluation. Additionally, this technique is largely insensitive to susceptibility effects, providing detailed anatomy-true diffusion imaging for brain, spine, breast and prostate. In combination with the DTI Tractography package, RESOLVE enables excellent white-matter tract imaging even in the most challenging areas, such as the cervical spine.

RESOLVE and QuietX DWI together make up the Advanced Diffusion package.

- Diffusion-weighted, readout-segmented (multi shot) EPI sequence for high-resolution susceptibility-insensitive DWI
- Variable number of readout segments for greater flexibility
- 2D navigator-based phase correction for pulsation artifact reduction and automatic reacquisition of corrupted data
- Inline calculation of diffusion tensor (DTI) and diffusion parameter maps

Tim Whole Body Suite

MAGNETOM Avanto^{fit} features a full effective Field of View of 205 cm.

Table movement to its full extent can be controlled from the *syngo* Acquisition Workplace.

The large FoV helps in imaging metastases with sequences such as TIRM (Turbo Inversion Recovery Magnitude). Whole body MR Angiography is possible on the entire volume with iPAT.

- Max. scan range of 205 cm
- Protocols and programs for whole body MR Angiography and metastases detection

¹⁾ MR imaging of patients with metallic implants brings specific risks. However, certain implants are approved by the governing regulatory bodies to be MR conditionally safe. For such implants, the previously mentioned warning may not be applicable. Please contact the implant manufacturer for the specific conditional information. The conditions for MR safety are the responsibility of the implant manufacturer, not of Siemens.

MapIt

MapIt provides protocols and Inline calculation functionality to obtain parametric maps of T1, T2, T2*, R2 and R2* properties of the imaged tissue. The application range includes cartilage evaluation of joints and also the evaluation of other organs such as liver, kidney or prostate.

In particular, MapIt supports the user in detecting osteoarthritis of the joint based on the T1, T2, and T2* properties of the cartilage.

- 3D VIBE sequence for Inline T1 mapping
- Multi-echo spin echo sequence for Inline T2/R2 mapping
- Multi-echo gradient echo sequence for Inline T2*/R2* mapping
- Protocols for fully automated Inline parametric mapping

SWI (Susceptibility Weighted Imaging)

Siemens-unique sequence technique for Susceptibility Weighted Imaging

- Visualization of local changes of the magnetic field due to tissue properties in general and due to the presence of deoxygenated blood or blood decomposition products
- 3D GRE sequence with full flow compensation to support venous angiography
- Enhanced susceptibility weighting of the magnitude images by phase images to increase sensitivity to intracerebral hemorrhage

Inline BOLD Imaging (Blood Oxygen Level Dependent)

Examination of intrinsic susceptibility changes in different areas of the brain, induced by external stimulation (e.g. motor or visual). Automatic real-time calculation of z-score (t-test) maps with Inline Technology, for variable paradigms.

- Compatible with single-shot EPI with high susceptibility contrast for fast multi-slice imaging
- ART (Advanced Retrospective Technique) for fully automatic 3D retrospective motion correction, for 6 degrees of freedom (3 translations and 3 rotations)
- Mosaic images for efficient storage and transfer of large data sets
- 3D spatial filtering
- Inline calculation of t-statistics (t-maps) based on a general linear model (GLM) including the hemodynamic response function and correcting for slow drifts
- Overlay of inline calculated statistical results on the EPI images

Simultaneous Multi-Slice (SMS)

SMS is a revolutionary method to significantly reduce imaging times for diffusion and BOLD imaging through excitation and readout of multiple slices simultaneously. It is the only acceleration technique that does not result in SNR-related losses due to sub-sampling. Implementation includes a multi-band pulse coupled with the blipped CAIPIRINHA technique to minimize g-factor related SNR penalties.

- For diffusion-weighted imaging, slice acceleration can be used to reduce scan time and/or achieve higher spatial/diffusion resolution
- For BOLD, slice acceleration can be used to increase temporal sampling of BOLD data, for higher sensitivity to BOLD signal changes, and/or to increase slice coverage/resolution.
- SMS accelerated BOLD and diffusion-weighted protocols for the brain are provided

Neuro Perfusion

Inline Perfusion helps to streamline the clinical workflow by automating post-processing perfusion data during data acquisition. This makes it possible to see the clinical results immediately and facilitates instantaneous image quality assurance. Inline perfusion functionality is user-configurable. Neuro Perfusion measures perfusion deficits and assist in the diagnosis and grading of e.g. vascular deficiencies and brain tumors. Neuro Perfusion provides the inline calculation of relative Cerebral Blood Volume (rel CBV), corrected relative CBV, relative Cerebral Blood Flow (rel CBF), relative Mean Transit Time (MTT), Global Bolus Plot, Percentage of Baseline at Peak and a task card for detailed post-processing of brain perfusion data sets. It also features retrospective motion correction of the time series. Color display of the relMTT, relCBV, and relCBF is supported. Flexible selection of the Arterial Input Function (AIF) for more reliable analysis taking into account the dynamics over time of the contrast agent enrichment, as well as the use of automated local AIFs are available.

3D PACE

3D PACE (Prospective Acquisition CorrEction) enhances Inline BOLD imaging with motion correction during the acquisition of a BOLD exam.

In contrast to a retrospective motion correction that corrects previously acquired data, the unique 3D PACE tracks the head of the patient, correcting for motion in real time during the acquisition. This increases the data quality beyond what can be achieved with a retrospective motion correction. As a result the sensitivity and specificity of BOLD experiments are increased.

3D PACE (Continued)

- Fully automatic 3D prospective motion correction during data acquisition, for 6 degrees of freedom (3 translations and 3 rotations)
- Motion correction covering the complete 3D volume
- Provides high accuracy
- Substantially reduced motion-related artifacts in t-test calculations
- Significantly increased signal changes in the activated neuronal volume
- Increased functional MRI (fMRI) sensitivity and specificity

DTI (Diffusion Tensor Imaging)

Acquisition of data sets with multi-directional diffusion weighting to assess anisotropic diffusion properties of brain tissue

- Measurement of up to 256 directions of diffusion weighting with up to 16 different b-values
- Inline calculation of the diffusion tensor
- Inline calculation of Fractional Anisotropy (FA) maps (grey-value as well as color-coded for principle diffusion direction), Apparent Diffusion Coefficient (ADC) maps and trace-weighted images based on the tensor

Inline Composing

Automatic anatomical or angiographic composing of multiple adjacent coronal or sagittal images for presentation and further evaluation.

Composed images can be automatically loaded into Graphical Slice Positioning for planning purposes.

TWIST

This package contains a Siemens-unique sequence and protocols for advanced time-resolved (4D) MR angiography and dynamic imaging in general with high spatial and temporal resolution. TWIST supports comprehensive dynamic MR angio exams in all body regions. It offers temporal information of vessel filling in addition to conventional static MR angiography, which can be beneficial in detecting or evaluating malformations such as shunts. TWIST can be combined with water excitation.

New reconstruction algorithms for iPAT² enable highly efficient multi-directional parallel imaging.

NATIVE

Integrated software package with sequences and protocols for non-contrast enhanced 3D MRA with high spatial resolution. NATIVE particularly enables imaging of abdominal and peripheral vessel.

NATIVE offers:

- Non-contrast MRA
- Separate imaging of arteries and veins
- Visualization of – e.g. – renal arteries or peripheral vessels

The NATIVE package comprises:

- NATIVE TrueFISP
- NATIVE SPACE

QISS

Software package for non-contrast enhanced peripheral MR angiography based on quiescent interval single-shot imaging.

- ECG triggered
- Robust, 2D non-subtractive technology
- Set'n Go implementation (Dot AddIn) for workflow optimized application
- Allows export of all images in one series (Combined View)

ASL (Arterial Spin Labeling) 2D

Arterial Spin Labeling (ASL) is an MR technique using the water in arterial blood as an endogenous contrast agent to evaluate perfusion noninvasively. ASL provides unique insight into human brain perfusion and function by evaluating cerebral blood flow. ASL is capable of high spatial resolution perfusion imaging, making the technique very appealing in the evaluation of diseases, but also in basic neuroscience, e.g. for studies of functional CBF changes.

- Fully compatible with iPAT
- Includes 3D PACE motion correction for increased reliability
- Fully automated Inline calculation of relative blood flow color maps
- Supports the "Pulsed Arterial Spin Labeling" – technique (PASL)

ASL (Arterial Spin Labeling) 3D

Arterial Spin Labeling (ASL) is an MR technique using the water in arterial blood as an endogenous contrast agent to evaluate perfusion noninvasively. ASL 3D enables the physician to qualitatively assess perfusion throughout the whole brain without the use of a contrast agent.

- ASL 3D is a tool to acquire high spatial resolution brain perfusion-weighted images.
- Based on a 3D TGSE sequence for minimal low susceptibility and full brain coverage
- Higher SNR, optimized contrast uniformity and reduced motion sensitivity.
- Perfusion maps can be easily fused with anatomical images for detail evaluation in Neuro 3D.

Advanced Cardiac

This package contains special sequences and protocols for advanced cardiac imaging including 3D and 4D BEAT functionalities. It supports advanced techniques for ventricular function imaging, dynamic imaging, tissue characterization, coronary imaging, and more.

BEAT is a unique tool for fast and easy cardiovascular MR imaging. It provides 1-click switch from cine imaging to tagging for wall motion evaluation and 1-click switch from 2D to 3D imaging. BEAT automatically adjusts all parameters associated with the changes.

Cardiac and vessel morphology	<ul style="list-style-type: none">• Multi echo technique thalassemia assessment• 3D aortopathy imaging with free breathing (SPACE)
Morphology and global or regional ventricular wall motion analysis with BEAT	<ul style="list-style-type: none">• 3D cine acquisition for full CT-like heart coverage• 2D segmented FLASH for visualization of the regional wall motion using various tagging techniques (grid or stripes)
Dynamic myocardial imaging with BEAT	<ul style="list-style-type: none">• Ultra-fast, high-SNR sequence for dynamic imaging with GRE EPI contrast for stress and rest exams
Tissue characterization with BEAT	<ul style="list-style-type: none">• Robust myocardial tissue characterization with 3D PSIR (phase-sensitive inversion recovery), e.g. after myocardial infarction or for differentiation of cardiomyopathies.• Fast and complete coverage of the myocardium with IR 3D FLASH and TrueFISP
Coronary imaging with BEAT	<ul style="list-style-type: none">• 3D whole heart non-contrast coronary MRA• 3D whole heart MRA with advanced free-breathing navigator compensating diaphragm shifts during the acquisition (motion-adaptive respiratory gating)

MyoMaps

On the basis of fully system guided HeartFreeze Inline Motion Correction, MyoMaps provides pixel-based T1, T2 and T2* myocardial tissue quantification. Results are presented in fully system guided inline colored parametric maps of the heart.

T1 Map	– based on Modified Look-Locker Inversion Recovery T1 mapping for e.g. detection of global, diffuse and sometimes subtle myocardial pathologies.
T2 Map	– based on T2-prepared single shot TrueFISP T2 mapping for e.g. depiction of cardiac edema.
T2* Map	– based on a multi-echo segmented gradient echo acquisition with black blood preparation for e.g. evaluation of iron overload.

Flow Quantification

Special sequences for quantitative flow determination studies

- Non-invasive blood/CSF flow quantification
- ECG Triggered 2D phase contrast with iPAT support
- Retrospective reconstruction algorithms for full R-R interval coverage

Interactive Realtime

Sequences and hardware for interactive real-time scanning

Uses ultra-fast Gradient Echo sequences for high image contrast

Real-time reconstruction of the acquired data

The user can navigate in all planes on-the-fly during data acquisition

- Real-time cardiac examinations
- Real-time interactive slice positioning and slice angulation for scan planning

Realtime Interface

Adds advanced features to Interactive Realtime (prerequisite licence)

Features:

- Capability for multislice acquisition, definition of acquisition order, pausing, mosaic display, and skipping of the physiology trigger
- Interface to 3rd party computers for:
 - sending to the 3rd party computer images from Interactive Real-Time and/or
 - receiving from the 3rd party computer protocol parameters for image acquisition.

Active Tip Tracking¹⁾

Adds software capability and interface for adjusting the real-time imaging slice position and orientation so as to follow interactive devices equipped with receive micro-coils.

Single Voxel Spectroscopy

Integrated software package with sequences and protocols for proton spectroscopy. Streamlined for easy push-button operation

- Matrix Spectroscopy – phase-coherent signal combination from several coil elements for maximum SNR based on the Head/Neck 20
- Spectral suppression (user definable parameter) to avoid lipid superposition in order to reliably detect e.g. choline in the breast
- Up to 8 regional saturation (RSat) bands for outer volume suppression can be defined by the user
- Automatic reference scan to allow less evaluation time
- Physiological triggering (ECG, pulse, respiratory or external trigger) in order to avoid e.g. breathing artifacts.
- Spectroscopy can be combined with Free-Breath Prospective Acquisition Correction (2D-Phase navigator) when needed
- Spectroscopy relevant GRE-based shim protocols provided
- Clinical applications: brain, breast, prostate

SVS Techniques SE and STEAM

- Short TEs available
- Fully automated adjustments including localized shimming and adjustment of water suppression pulses
- Also available: Interactive adjustments and control of adjustments
- Optimized protocols for brain applications

¹⁾ Precondition: Realtime Interface

CSI 2D: Chemical Shift Imaging

Integrated software package with sequences and protocols for Chemical Shift Imaging (CSI)

Extension of the Single Voxel Spectroscopy (SVS) package, offering the same level of user-friendliness and automation

- Matrix Spectroscopy – phase-coherent signal combination from several coil elements for maximum SNR with configurable prescan-based normalization for optimal homogeneity
- 2D Chemical Shift Imaging
- Hybrid CSI with combined volume selection and Field of View (FoV) encoding
- Short TEs available (30 ms for SE, 20 ms for STEAM)
- Automated shimming of the higher order shimming channels for optimal homogeneity of the larger CSI volumes
- Weighted acquisition, leading to a reduced examination time compared to full k-space coverage while keeping SNR and spatial resolution
- Outer Volume Suppression
- Spectral Suppression

CSI 3D: Chemical Shift Imaging

Integrated software package with sequences and protocols for Chemical Shift Imaging (CSI)

Extension of the SVS package, offering the same level of user-friendliness and automation

- Matrix Spectroscopy – phase-coherent signal combination from several coil elements for maximum SNR with configurable prescan-based normalization for optimal homogeneity
- 3D Chemical Shift Imaging
- Hybrid CSI with combined volume selection and Field of View (FoV) encoding
- Short TEs available (30 ms for SE, 20 ms for STEAM)
- Automated shimming of the higher order shimming channels for optimal homogeneity of the larger CSI volumes
- Weighted acquisition, leading to a reduced examination time compared to full k-space coverage while keeping SNR and spatial resolution
- Outer Volume Suppression
- Spectral Suppression
- Protocols for prostate spectroscopy

GRACE (GeneRALized breast speCtroscopy Exam)

SVS technique (spin echo sequence) optimized for breast spectroscopy.

The technique contains a special spectral lipid suppression pulse (user definable) for lipid signal reduction.

Siemens unique water reference detection to visualize the normalized choline ratio.

Online frequency shift correction for reduction of breathing related artifacts, Inline implementation – no additional user interaction is required.

Clinical applications:

- Can help the physician improve the specificity for tumor diagnoses
- Predicting clinical response to neoadjuvant chemotherapy in an early stage (24hours after receiving the first dose)

Security

This *syngo* software version provides security settings to protect the scanner against known security threats.

- New Security Delivery process to frequently distribute security updates
- Whitelisting (Embedded Control) against manipulation of scanner software
- Option to protect customer protocol trees against unauthorized modifications

Enhanced Security¹⁾

The Security Enhanced option additionally allows the assignment of different user roles to users and the allocation of patients to different patient groups.

- It also allows configuration of trusted nodes and DICOM encryption.
- It supports customers to implement their security policy including compliance with HIPAA (Health Insurance and Accountability Act)

MR Elastography

MR Elastography provides the possibility to non-invasively assess variations in tissue stiffness to improve diagnosis for treatment decisions especially in liver fibrosis.

MR Elastography includes pulse sequence and processing software.*

- Sequence and protocols with 2D gradient-echo sequences with cyclic motion-encoding gradients (MEG)

Advanced Siemens implementation

- iPAT enables shortened breath-hold time
- Fully integrated processing of the elastogram at the scanner
- Completely automated calculation of wave images and corresponding elastograms
- Confidence map for reliability

* Please note that this functionality can only be used in combination with a dedicated hardware, which is not part of the MR Elastography package.

¹⁾ Option

Expert-i¹⁾

Interactive real-time access to imaging data and exam information from any PC within the hospital network during the MR exam.

Until now, radiologists or other experts had to stop what they were doing and go to the MR scanner to see the acquired images, help with the scan set-up, or answer an open question.

Now, questions can be addressed quickly and efficiently via remote PC.

Benefits of Expert-i	<ul style="list-style-type: none">• Excellent results right from the first examination• Streamlined workflow and faster patient throughput• Reduced repeat rates with a check on images while the patient is still in the examination room• Reduced training effort by enabling expert assistance for specialized procedure
----------------------	--

Remote Assist

Direct computer link to the local Siemens service department or the Siemens service centers (via router with telephone connection)

Image transfer for further evaluation	<ul style="list-style-type: none">• Image and file transfer in batch mode• Reading of entries in the error logbook• Remote trouble shooting• Remote access to service manuals written in easy-to-use HTML format• Remote access to Service Site Database• Start of preventive maintenance and quality assurance routines. Provided in conjunction with a service contract with Siemens (UPTIME Services)• Remote access granted only with permission of the institution. Data security is ensured by secure access
---------------------------------------	--

IDEA (Integrated Development Environment for Applications)

Extensive programming environment used to create and modify pulse sequences, offering a maximum of flexibility

Based on C++ for Windows XP. Sequences and RF pulses are displayed in a visual interface

Features	<ul style="list-style-type: none">• Allows direct access to the Image Calculation Environment (ICE), and to all protocols• Testing the generated code is extensively supported by the debugger and the simulation program• IDEA is also usable on any standard PC with operating system Windows XP making developments independent of the MR system
Processing plug-ins	<p>For development or modification of user-defined image processing steps which may be integrated into the measurement protocols</p> <ul style="list-style-type: none">• Individual processing is secured by a number of functions (e.g. TTP and MTT), useful for neuro or perfusion imaging
Prerequisite	IDEA training course

¹⁾ Within the hospital enterprise

Not for distribution in the US.

The products/features (here mentioned) are not commercially available in all countries. Due to regulatory reasons their future availability cannot be guaranteed. Please contact your local Siemens Healthcare organization for further details.

The information in this document contains general technical descriptions of specifications and options as well as standard and optional features which do not always have to be present in individual cases.

Original images always lose a certain amount of detail when reproduced

Siemens Healthcare reserves the right to modify the design, packaging, specifications and options described herein without prior notice. Please contact your local Siemens Healthcare sales representative for the most current information.

Note: Any technical data contained in this document may vary within defined tolerances.

Please find fitting accessories:
[healthcare.siemens.com/
accessories-oem-equipment](http://healthcare.siemens.com/accessories-oem-equipment)

Siemens Healthcare Headquarters

Siemens Healthcare GmbH
Henkestr. 127
91052 Erlangen
Germany
Telephone: +49 9131 84-0
siemens.com/healthcare

Legal Manufacturer

Siemens Healthcare GmbH
Henkestr. 127
91052 Erlangen
Germany



SIEMENS



[siemens.com/avanto-fit](https://www.siemens.com/avanto-fit)

MAGNETOM Avanto^{fit}

Post-processing Packages

Post-processing Packages

All post-processing packages are separately available for the *syngo* Acquisition Workplace or the *syngo* MR Workplace.

Argus 4D Ventricular Function

Argus 4D VF software processes MR cine images of the heart and generates quantitative results for physicians in the diagnostic process. It provides volumetric cardiac data of a given patient very quickly and easily. Parametric results and volume-time curves are being calculated upon automatic creation and adaptation of a 4D model of the left ventricle. The resulting 4D model of the patient's heart can be visualized superimposed to anatomical images as reference.

Argus 4D VF includes the well-known functionalities of Argus Function, the automated tool for cardiac function evaluation.

- Fully automatic left ventricle and semi-automatic right ventricular segmentation
- Easy user guidance with graphical selection of ED, ES, basal and apical slices
- Volumetric and regional wall motion analysis (e.g. stroke volume and bull's-eye plots)

Argus Flow

Automated tool for analysis of blood and CSF flow.

- Semi-automatic detection of regions of interest over time
- Color-coded display of velocity values
- Calculation of flow and velocity parameters (e.g. peak velocity, average velocity, flow, integral flow)

Argus Dynamic Signal

Automated tool for dynamic data analysis.

- Manual or automatic segmentation
- Automatic compensation of contours in regard to translation or deformation of organs over time
- Sector-based or ROI-based evaluation
- Evaluation of Time-to-Peak, Peak Value, Uptake Slope, Area under the Curve
- Graphical display of results in parametric bull's eye plots

Vessel View

Interactive analysis of vessel disease using MR or CT angiography data.

Viewing with VRT, MPR or MIP mode.

- Semi-automatic detection of vessel segments
- Quantification of changes in vessel size (e.g. stenosis graduating, aneurysm volume measurement)
- Protocol-based software for workflow support
- Creates and edits DICOM structured reports

Vessel View Artery-Vein-Separation

This package allows semi-automated segmentation and separation of arteries and veins, as well as suppression of surrounding tissue. Supports modes allowing the display of only arteries or only veins, or arteries and veins together in different colors. (Prerequisite: Vessel View)

3D VRT Volume Rendering Technique

3D visualization for clearer depiction of complex anatomy and relationship of anatomy in 3D for contrast MR Angiography and VIBE imaging.

More productive surgical planning and discussion with referring physicians.

- Integrated with other 3D functionality
- Color image creation
- Color gallery of icon presets
- Additional threshold-based segmentation of 3D objects
- Volume measurements

BOLD 3D Evaluation

Comprehensive processing and visualization package for BOLD fMRI. It provides a full set of features for clinical fMRI, as well as advanced features for more research oriented applications.

This package provides statistical map calculations from BOLD datasets and enables the visualization of task-related areas of activation with 2D or 3D anatomical data. This allows the visualization of the spatial relation of eloquent cortices with cortical landmarks or brain lesions.

On the *syngo* Acquisition Workplace the unique Inline function of BOLD 3D Evaluation merges, in real time, the results of ongoing BOLD imaging measurements with 3D anatomical data. Additionally, evolving signal time courses in task-related areas of activation can be displayed and monitored.

Functional and anatomical image data can be exported for surgical planning as DICOM datasets, additionally all color fused images and results can be stored or printed.

- Statistical map generation: paradigm definition, calculation of t-value map with General Linear Model or t-test
- 3D Visualization: fused display of fMRI results, color t-value maps on anatomical datasets
- Inline 3D real time monitoring of the fMRI acquisition
- On-the-Fly Adjustment for t-value thresholding, 3D clustering, and opacity control
- Data export to neurosurgical planning software
- Fly Through the Volume: Zoom, pan, rotate, cut planes
- Analysis of Signal Time Curves
- Data Quality Monitoring: B0 field map, cine display of the BOLD time series
- Archiving & Distribution of results and views as colored DICOM images and bit maps
- If the respective options are available, results from Diffusion Tensor Imaging and DTI Tractography can be displayed together with fMRI results and anatomy

DTI Evaluation

Offline post-processing to generate and visualize parametric maps derived from the diffusion tensor in order to assess anisotropic diffusion properties of brain tissue

- Generation of diffusion maps based on tensor including: Fractional Anisotropy (FA), Volume Ratio (VR), trace-weighted, ADC, E1–E3, E1, linear, planar, tensor maps
- Display of maps in scalar mode (grey scale), vectorized mode (directions color coded) and tensorized mode (using tensor graphics like ellipsoid or cuboids); overlay of maps onto anatomical images
- Side by side display of several maps (e.g. ADC, FA, and trace-weighted) and anatomy for simultaneous ROI based evaluation; generation of a results table in order to support the assessment of diseases of the white matter
- Integrated into Neuro 3D taskcard: display of DTI maps in the context of an anatomical 3D data set; arbitrary oriented clip planes allow to explore the 3D volume
- Fused display with white matter tracts if the “DTI Tractography” option is present.
- Export of reformatted images for neuro navigation
- Together with the “BOLD 3D Evaluation” option: simultaneous display of anatomical, fMRI, and DTI data

DTI Tractography

DTI Tractography allows the visualization of multiple white matter tracts based on diffusion tensor imaging data. DTI Tractography is optimized to support the presurgical planning and to allow for neuro physiological research with respect to connectivity and white matter pathology.

- Advanced 3D visualization of white matter tracts in the context of 2D or 3D anatomical and DTI datasets
- Texture Diffusion, a highly versatile in-plane visualization of white matter tracts, allows to display and read DTI Tractography results on PACS reading stations and in the OR
- Seed points for tracking with single ROI and with multiple ROIs to assess connectivity
- Tract and seeding ROI statistics (mean / max FA value, min / mean / max ADC value, and more)
- DICOM export of views, HTML export of Tract, and seeding ROI statistics
- Interactive QuickTracking displays the tract originating from the mouse pointer position while moving over the DTI data set

Neuro Perfusion Evaluation

Dedicated task card for quantitative processing of neuro perfusion data.

- Color display of relative Mean Transit Time (relMTT), relative Cerebral Blood Volume (relCBV), and relative Cerebral Blood Flow (relCBF)
- Flexible selection of Arterial Input Function (AIF) for reliable analysis. This function takes into account the dynamics over time of the contrast agent enhancement

Composing

Composing of images from different table positions.

- Automatic and manual composing of sagittal and coronal images
- Dedicated algorithms for spine, angiography, and adaptive composing algorithms
- Measurement on composed images (angle, distance)

Fly Through

Simulated endoscopic views of the inside of bronchi, vessels, colon, and any other hollow structures.

Multi-modality application for CT, MR, and 3D AX data.

Fully integrated into the familiar 3D workflow and user interface.

- Ready-to-use from day one
- One click to action

Spectroscopy Evaluation

Integrated software package with extensive graphical display functionality

Comprehensive and user-friendly evaluation of spectroscopy data

Display of CSI data as colored metabolite images or spectral overview maps, overlaid on anatomical images

- Export of spectroscopy data to a user-accessible file format
- Relative quantification of spectra, compilation of the data to result table

Automated peak normalization tissue, water or reference

New dedicated Single Voxel Spectroscopy breast evaluation protocols

Image Fusion

Image fusion of multiple 3D data sets with alpha blending, i.e. overlay of two images with manual setting of the opacity

- Multiple 3D data sets from different modalities (MR, CT, Nuclear Medicine, PET)
- Visual alignment, automatic registration, or landmark based registration

BreVis*

BreVis is easy-to-use, fast, and reliable. Quick preprocessing, which includes elastic motion correction in case of patient movement, enables efficient breast reading and reporting.

This flexible tool provides various functionalities such as:

- Intelligent visualization of 2D-, 3D- and 4D-datasets according to customized layouts, e.g. dedicated layouts for intervention, multiple time point follow-up
- Elastic Motion Correction
- Multi-modality viewing capabilities
- Reporting according to BI-RADS** standard
- On-the-fly reconstruction of subtracted images
- Auto-MultiPlanar Reformatted images (MPR) and auto-Maximum Intensity Projection (MIP)
- Real-time display and analysis of kinetic parameters (timecourse evaluation, color overlay maps to visualize angiogenesis or curve types)
- Graphical volume statistics of lesion enhancement
- Calculation of lesion volumes

* Not available on AQWP

** Breast Imaging Reporting and Data System

BreVis Biopsy

BreVis Biopsy is a professional solution for a fast and accurate MR biopsy workflow with automatic calculation of target coordinates.

The easy-to-handle workflow enables shorter examination times for both patient and operator. The user interface offers a guide for MR breast interventional planning, supporting the following biopsy systems:

- Sentinelle Breast coils, 4-channel BI Breast Coil
- Related accessories for the post-pillar and grid method

BreVis Biopsy enables path planning directly at the scanner – no sending of data over the network required.

Breast Biopsy Software

Easy to use *syngo*-based post-processing software helps finding the coordinates for needle insertion for biopsy or localization of breast lesions detected by MR

Allows calculation of the coordinates after clicking the center of the lesion and the 0 marker of a third party breast biopsy device

- Printout of working sheet
- Multi-lesion calculation

Prerequisites • 4-channel BI breast coil

Soft Tissue Motion Correction

3D elastic motion correction, for offline 3D correction in all directions over entire 2D and 3D data sets suitable for e.g. soft tissue MR exams.

Allows higher conspicuity and accuracy especially for multi-focal lesion detection.

New image data is reconstructed and saved in a separate series within the patient browser. It can be combined with the original non-corrected image data.

Tissue 4D

Tissue 4D facilitates the detection of tumor tissues in organs the perfusion of which can be described by the Tofts model, such as the prostate.

It is an application card for visualizing and post-processing dynamic contrast-enhanced 3D datasets.

Evaluation options	<ul style="list-style-type: none">• Standard curve evaluation• Curve evaluation according to a pharmacokinetic model
Visualization features	<p>4D visualization (3D and over time)</p> <p>Color display of parametric maps describing the contrast media kinetics such as:</p> <ul style="list-style-type: none">• Transfer constant (K_{trans})• Reflux constant (K_{ep})• Extra vascular extra cellular volume fraction (V_e)• Plasma volume fraction (V_p)• Initial Area-Under-Curve (iAUC) for the first 60 seconds <p>Additional visualization of 2D or 3D morphological dataset</p>
Post-processing features	<p>Elastic 3D motion correction</p> <p>Fully automatic calculation of subtracted images</p>
Pharmacokinetic model	<p>Pharmacokinetic calculation on a pixel-by-pixel basis using a 2-compartment model.</p> <p>Calculation is based on the Tofts model. Various model functions are available.</p> <p>Manual segmentation and calculation on the resulting images.</p> <p>The following resulting images can be saved as DICOM images:</p> <ul style="list-style-type: none">• 3D motion-corrected, dynamic images• Colored images• Storage of calculated results• Export of results in the relevant layout format

Not for distribution in the US.

The products/features (here mentioned) are not commercially available in all countries. Due to regulatory reasons their future availability cannot be guaranteed. Please contact your local Siemens Healthcare organization for further details.

The information in this document contains general technical descriptions of specifications and options as well as standard and optional features which do not always have to be present in individual cases.

Original images always lose a certain amount of detail when reproduced

Siemens Healthcare reserves the right to modify the design, packaging, specifications and options described herein without prior notice. Please contact your local Siemens Healthcare sales representative for the most current information.

Note: Any technical data contained in this document may vary within defined tolerances.

Please find fitting accessories:
[healthcare.siemens.com/
accessories-oem-equipment](http://healthcare.siemens.com/accessories-oem-equipment)

Siemens Healthcare Headquarters

Siemens Healthcare GmbH
Henkestr. 127
91052 Erlangen
Germany
Telephone: +49 9131 84-0
siemens.com/healthcare

Legal Manufacturer

Siemens Healthcare GmbH
Henkestr. 127
91052 Erlangen
Germany

SIEMENS



[siemens.com/avanto-fit](https://www.siemens.com/avanto-fit)

MAGNETOM Avanto^{fit}

syngo.via and MAGNETOM Avanto^{fit}

syngo.via and MAGNETOM Avanto^{fit}

syngo.via is our advanced imaging software, creating an exciting experience in efficiency and ease of use – anywhere¹⁾. syngo.via is your agent for productivity throughout your radiology workflow. From scanning to result sharing.

Integrated Engine concept

The Engine concept integrates the scanning and reading processes into one holistic workflow and enables you to maximize your scanner and application investment.

Key features	The Dot (Day optimizing throughput) engines optimize the performance of MAGNETOM Avanto ^{fit} and offer patient personalization, user guidance, and exam automation.
	syngo.via offers reading workflows, which are optimally adjusted to the Dot engines for the best reading outcomes
	The scanning and reading workflows are easily customizable to the user's standards of care.
	Results from the scanner are optimally displayed in the reading workflows.
Key benefits	Guidance, standardization and flexibility is offered for every step of the workflow, reducing the need for further inquiry
	Increasing throughput, minimizing recalls, and enhancing quality of care.

1) Prerequisites include: internet connection to clinical network, DICOM compliance, meeting of minimum hardware requirements and adherence to local data security regulations

Direct Image Transfer (DIT)

After completion of a series of images, they are transferred automatically to *syngo.via*. Easily view the images with any *syngo.via* client immediately after they were acquired.

Key features	This data will be automatically transferred to the <i>syngo.via</i> data base and loaded into the related workflow. Enhanced DICOM MR enables the transfer of data and data in DICOM standard format. <i>syngo.via</i> and any PACS supporting this standard can work with this data.
Key benefits	Images are immediately available throughout the institution. This enables fast and convenient feedback from everywhere.
Direct Image Transfer Pro	The MAGNETOM scanner and <i>syngo.via</i> server are directly connected, enabling image transfer.

Not for distribution in the US.

The products/features (here mentioned) are not commercially available in all countries. Due to regulatory reasons their future availability cannot be guaranteed. Please contact your local Siemens Healthcare organization for further details.

The information in this document contains general technical descriptions of specifications and options as well as standard and optional features which do not always have to be present in individual cases.

Original images always lose a certain amount of detail when reproduced

Siemens Healthcare reserves the right to modify the design, packaging, specifications and options described herein without prior notice. Please contact your local Siemens Healthcare sales representative for the most current information.

Note: Any technical data contained in this document may vary within defined tolerances.

Please find fitting accessories:
[healthcare.siemens.com/
accessories-oem-equipment](http://healthcare.siemens.com/accessories-oem-equipment)

Siemens Healthcare Headquarters

Siemens Healthcare GmbH
Henkestr. 127
91052 Erlangen
Germany
Telephone: +49 9131 84-0
siemens.com/healthcare

Legal Manufacturer

Siemens Healthcare GmbH
Henkestr. 127
91052 Erlangen
Germany

SIEMENS



[siemens.com/avanto-fit](https://www.siemens.com/avanto-fit)

MAGNETOM Avanto^{fit}

Parts & Accessories

Parts & Accessories

Patient Video Monitoring

Dedicated MAGNETOM Avanto^{fit} video camera for comprehensive patient observation in the examination room and waiting room observation.

- Up to two in-room cameras for optimized patient observation from front end and rear-end
- Up to two waiting room cameras for observing the situation in the waiting room
- Color 640×480 pixel LCD monitor may be positioned at the *syngo* Acquisition Workplace or at a convenient wall location
- Possibility to switch between 4 camera layout and single camera layout

Remote Viewing Monitor

Color LCD monitor (1280×1024) to be connected in parallel to the Workplace monitor.

Data transfer via ethernet for high signal quality over a long distance allows the computer and user to be located anywhere on the 100 or 1000 Mbps network with full routing of data across routers, switches and subnets (1 Gbit/s recommended).

The system supports SSL (Secure Sockets Layer) via a TCP/IP connection. All media streams transferred in the network are encrypted.

Additional Dot Control Center Rear

Additional Dot Display and Dot Control Center Rear, e.g. for interventional procedures. Located at the rear end of the system.

Foot Switch

In-room foot switch with two pneumatic buttons for start and stop of a preset MR sequence. The foot switch is MR compatible and is positioned near the patient table on the examination room floor.

syngo MR Workplace

Additional integrated Workplace with host computer for post-processing and image evaluation.

Same user interface as the *syngo* Acquisition Workplace, except for scan control.

Shared database with *syngo* Acquisition Workplace, therefore eliminating image copy time.

► Host Computer and LCD Monitor technical data: refer to "Computer System" section of the main data sheet.

Workplace Table

Ergonomically designed table for:

- Color monitor
- Keyboard
- Mouse
- Patient communication unit
- Patient supervision display

Patient Transport Stretcher

MR-compatible design on wheels for transporting a patient into the examination room.

Useful when the removable tabletop and trolley option are not purchased

- Non-ferromagnetic, height-adjustable design
- Trendelenburg positioning possible

Max. patient weight	160 kg (350 lbs)
---------------------	------------------

Comfort Kit

Vacuum cushions for stable and comfortable positioning of the patient during the examination

Vacuum pump connection at the Tim Table

3 anatomically shaped cushions of different size for patient stabilization and comfort (spine, head, multi-purpose)

May significantly reduce patient set-up times and improve image quality by minimizing the occurrence of motion artifacts

Coil Storage Cart

Specially designed non-ferromagnetic cart for easy storage of some of the most commonly used coils and accessories

May be rolled to convenient locations in the examination room

Additional storage space on the inside of the doors when doors are opened

Coil storage	Width	cart closed	140 cm (4'7")
		cart opened	280 cm (9'2")
	Depth		54 cm (1'9")
	Height		121 cm (3'12")
Upper drawer	Height		13.3 cm
Tray	Height		9.0 cm
Lower drawer	Height		24.0 cm

> Additional optional accessories and consumables for MR: [siemens.com/avanto-fit-accessories](https://www.siemens.com/avanto-fit-accessories)



Not for distribution in the US.

The products/features (here mentioned) are not commercially available in all countries. Due to regulatory reasons their future availability cannot be guaranteed. Please contact your local Siemens Healthcare organization for further details.

The information in this document contains general technical descriptions of specifications and options as well as standard and optional features which do not always have to be present in individual cases.

Original images always lose a certain amount of detail when reproduced

Siemens Healthcare reserves the right to modify the design, packaging, specifications and options described herein without prior notice. Please contact your local Siemens Healthcare sales representative for the most current information.

Note: Any technical data contained in this document may vary within defined tolerances.

Please find fitting accessories:
[healthcare.siemens.com/
accessories-oem-equipment](http://healthcare.siemens.com/accessories-oem-equipment)

Siemens Healthcare Headquarters

Siemens Healthcare GmbH
Henkestr. 127
91052 Erlangen
Germany
Telephone: +49 9131 84-0
siemens.com/healthcare

Legal Manufacturer

Siemens Healthcare GmbH
Henkestr. 127
91052 Erlangen
Germany

MAGNETOM Avanto^{fit}
Datasheet-Box Content
syngo MR E11C

Sales Project / Customer

Part of Tender	Document/Title	Legal Manufacturer	Printkey/Document ID
<input type="checkbox"/>	MAGNETOM Avanto ^{fit} – A Tim+Dot System – Data Sheet	Siemens	Order No. A91MR-500E-11-7600G Printed in Germany MC.MR-00500 PA 0416 POD © Siemens Healthcare GmbH, 2016
<input type="checkbox"/>	MAGNETOM Avanto ^{fit} , Tim Dockable Table	Siemens	Order No. A91MR-500E-12-7600G Printed in Germany MC.MR-00500 PA 0416 POD © Siemens Healthcare GmbH, 2016
<input type="checkbox"/>	MAGNETOM Avanto ^{fit} , Head/Neck 20	Siemens	Order No. A91MR-500E-A101-7600G Printed in Germany MC.MR-00500 PA 0416 POD © Siemens Healthcare GmbH, 2016
<input type="checkbox"/>	MAGNETOM Avanto ^{fit} , Spine 32	Siemens	Order No. A91MR-500E-A102-7600G Printed in Germany MC.MR-00500 PA 0416 POD © Siemens Healthcare GmbH, 2016
<input type="checkbox"/>	MAGNETOM Avanto ^{fit} , Body 6	SSMR	Order No. A91MR-500E-A103-7600G Printed in Germany MC.MR-00500 PA 0416 POD © Siemens Healthcare GmbH, 2016
<input type="checkbox"/>	MAGNETOM Avanto ^{fit} , Body 18	Siemens	Order No. A91MR-500E-A105-7600G Printed in Germany MC.MR-00500 PA 0416 POD © Siemens Healthcare GmbH, 2016
<input type="checkbox"/>	MAGNETOM Avanto ^{fit} , Body 18 Long	Siemens	Order No. A91MR-500E-A106-7600G Printed in Germany MC.MR-00500 PA 0416 POD © Siemens Healthcare GmbH, 2016
<input type="checkbox"/>	MAGNETOM Avanto ^{fit} , Body 30	Siemens	Order No. A91MR-500E-A107-7600G Printed in Germany MC.MR-00500 PA 0416 POD © Siemens Healthcare GmbH, 2016
<input type="checkbox"/>	MAGNETOM Avanto ^{fit} , Flex Large 4 / Flex Small 4	Siemens	Order No. A91MR-500E-A108-7600G Printed in Germany MC.MR-00500 PA 0416 POD © Siemens Healthcare GmbH, 2016
<input type="checkbox"/>	MAGNETOM Avanto ^{fit} , Peripheral Angio 36	Siemens	Order No. A91MR-500E-A109-7600G Printed in Germany MC.MR-00500 PA 0416 POD © Siemens Healthcare GmbH, 2016
<input type="checkbox"/>	MAGNETOM Avanto ^{fit} , Loop Coils	Siemens	Order No. A91MR-500E-A110-7600G Printed in Germany MC.MR-00500 PA 0416 POD © Siemens Healthcare GmbH, 2016
<input type="checkbox"/>	MAGNETOM Avanto ^{fit} , Hand/Wrist 16	SSMR	Order No. A91MR-500E-A111-7600G Printed in Germany MC.MR-00500 PA 0416 POD © Siemens Healthcare GmbH, 2016
<input type="checkbox"/>	MAGNETOM Avanto ^{fit} , Foot/Ankle 16	SSMR	Order No. A91MR-500E-A112-7600G Printed in Germany MC.MR-00500 PA 0416 POD © Siemens Healthcare GmbH, 2016
<input type="checkbox"/>	MAGNETOM Avanto ^{fit} , Shoulder Large 16 / Shoulder Small 16	SSMR	Order No. A91MR-500E-A113-7600G Printed in Germany MC.MR-00500 PA 0416 POD © Siemens Healthcare GmbH, 2016
<input type="checkbox"/>	MAGNETOM Avanto ^{fit} , CP Extremity Coil	Siemens	Order No. A91MR-500E-A114-7600G Printed in Germany MC.MR-00500 PA 0416 POD © Siemens Healthcare GmbH, 2016
<input type="checkbox"/>	MAGNETOM Avanto ^{fit} , Tx/Rx 15-Channel Knee Coil	QED	Order No. A91MR-500E-A115-7600G Printed in Germany MC.MR-00500 PA 0416 POD © Siemens Healthcare GmbH, 2016
<input type="checkbox"/>	MAGNETOM Avanto ^{fit} , Tx/Rx CP Head Coil	QED	Order No. A91MR-500E-A116-7600G Printed in Germany MC.MR-00500 PA 0416 POD © Siemens Healthcare GmbH, 2016
<input type="checkbox"/>	MAGNETOM Avanto ^{fit} , 4-Channel BI Breast Coil	Noras	Order No. A91MR-500E-A117-7600G Printed in Germany MC.MR-00500 PA 0416 POD © Siemens Healthcare GmbH, 2016
<input type="checkbox"/>	MAGNETOM Avanto ^{fit} , 16-Channel AI Breast Coil	RAPID	Order No. A91MR-500E-A118-7600G Printed in Germany MC.MR-00500 PA 0416 POD © Siemens Healthcare GmbH, 2016
<input type="checkbox"/>	MAGNETOM Avanto ^{fit} , 2- / 4- / 8-Channel Sentinelle Breast Coil	Invivo	Order No. A91MR-500E-A119-7600G Printed in Germany MC.MR-00500 PA 0416 POD © Siemens Healthcare GmbH, 2016
<input type="checkbox"/>	MAGNETOM Avanto ^{fit} , 8-Channel Configuration / Upgrade to Biopsy Configuration	Invivo	Order No. A91MR-500E-A120-7600G Printed in Germany MC.MR-00500 PA 0416 POD © Siemens Healthcare GmbH, 2016
<input type="checkbox"/>	MAGNETOM Avanto ^{fit} , 2-/10-/16-Channel Sentinelle Breast Coil	Invivo	Order No. A91MR-500E-A121-7600G Printed in Germany MC.MR-00500 PA 0416 POD © Siemens Healthcare GmbH, 2016
<input type="checkbox"/>	MAGNETOM Avanto ^{fit} , 16-Channel Sentinelle Breast Coil	Invivo	Order No. A91MR-500E-A122-7600G Printed in Germany MC.MR-00500 PA 0416 POD © Siemens Healthcare GmbH, 2016
<input type="checkbox"/>	MAGNETOM Avanto ^{fit} , 18-Channel Breast Coil	Siemens	Order No. A91MR-500E-A123-7600G Printed in Germany MC.MR-00500 PA 0416 POD © Siemens Healthcare GmbH, 2016
<input type="checkbox"/>	MAGNETOM Avanto ^{fit} , Sentinelle Endorectal Coil	Invivo	Order No. A91MR-500E-A124-7600G Printed in Germany MC.MR-00500 PA 0416 POD © Siemens Healthcare GmbH, 2016
<input type="checkbox"/>	MAGNETOM Avanto ^{fit} , Endorectal Coil	Bayer	Order No. A91MR-500E-A125-7600G Printed in Germany MC.MR-00500 PA 0416 POD © Siemens Healthcare GmbH, 2016
<input type="checkbox"/>	MAGNETOM Avanto ^{fit} , Pediatric 16	QED	Order No. A91MR-500E-A126-7600G Printed in Germany MC.MR-00500 PA 0416 POD © Siemens Healthcare GmbH, 2016
<input type="checkbox"/>	MAGNETOM Avanto ^{fit} , 4-Channel Special-Purpose Coil	SSMR	Order No. A91MR-500E-A127-7600G Printed in Germany MC.MR-00500 PA 0416 POD © Siemens Healthcare GmbH, 2016
<input type="checkbox"/>	MAGNETOM Avanto ^{fit} , Application Packages	Siemens	Order No. A91MR-500E-B1-7600G Printed in Germany MC.MR-00500 PA 0416 POD © Siemens Healthcare GmbH, 2016
<input type="checkbox"/>	MAGNETOM Avanto ^{fit} , Post-processing Packages	Siemens	Order No. A91MR-500E-C1-7600G Printed in Germany MC.MR-00500 PA 0416 POD © Siemens Healthcare GmbH, 2016
<input type="checkbox"/>	MAGNETOM Avanto ^{fit} , syngo.via and MAGNETOM Avanto ^{fit}	Siemens	Order No. A91MR-500E-D1-7600G Printed in Germany MC.MR-00500 PA 0416 POD © Siemens Healthcare GmbH, 2016
<input type="checkbox"/>	MAGNETOM Avanto ^{fit} , Parts & Accessories	Siemens	Order No. A91MR-500E-E1-7600G Printed in Germany MC.MR-00500 PA 0416 POD © Siemens Healthcare GmbH, 2016
	Backpage (Printnumber of Package)	Siemens	Order No. A91MR-500E-10-7600G Printed in Germany MC.MR-00500 PA 0416 POD © Siemens Healthcare GmbH, 2016

Not for distribution in the US.

The products/features (here mentioned) are not commercially available in all countries. Due to regulatory reasons their future availability cannot be guaranteed. Please contact your local Siemens Healthcare organization for further details.

The information in this document contains general technical descriptions of specifications and options as well as standard and optional features which do not always have to be present in individual cases.

Original images always lose a certain amount of detail when reproduced

Siemens Healthcare reserves the right to modify the design, packaging, specifications and options described herein without prior notice. Please contact your local Siemens Healthcare sales representative for the most current information.

Note: Any technical data contained in this document may vary within defined tolerances.

Please find fitting accessories:
[healthcare.siemens.com/
accessories-oem-equipment](http://healthcare.siemens.com/accessories-oem-equipment)

Siemens Healthcare Headquarters

Siemens Healthcare GmbH
Henkestr. 127
91052 Erlangen
Germany
Telephone: +49 9131 84-0
siemens.com/healthcare

Legal Manufacturer

Siemens Healthcare GmbH
Henkestr. 127
91052 Erlangen
Germany