

# Brief Update on the PRad-II Proposal

Haiyan Gao  
Duke University  
For the PRad Collaboration

# PR<sup>o</sup>ton R<sup>a</sup>d<sup>i</sup>us

PRad-II C1  
Review

March 12, 2021

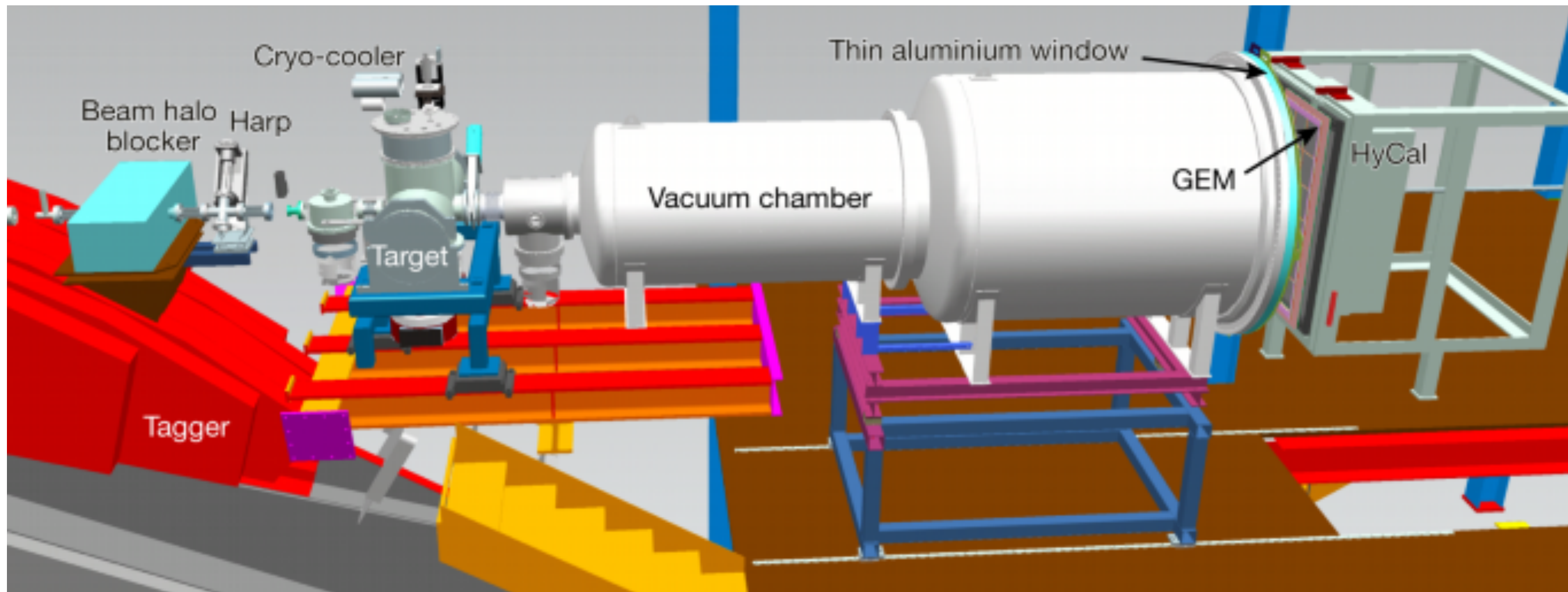

# Overview of PRad-II

- **PRad-II goal – Reduce the uncertainty of the  $r_p$  by a factor of 3.8!**
  - Resolve discrepancy with Mainz data on the proton electric form factor
- **Upgrades and Improvements from PRad**
  - Improving tracking capability by adding a second plane of tracking detector
  - Upgrading HyCal to all PbWO<sub>4</sub> modules to improve uniformity, resolutions and suppress inelastic contamination
  - Improve DAQ rate by converting to FADC based readout
  - Suppressing beamline background
    - Improving vacuum
    - Adding second beam halo blocker upstream of the tagger
  - Reducing statistical uncertainties by a factor of 4 compared with PRad
  - Improve radiative correction calculations by going to NNL order
- **PRad-II will reach an unprecedented low values of  $Q^2$  :  $4 \times 10^{-5} \text{ (GeV/c)}^2$** 
  - Adding new rectangular cross shaped scintillator detectors to separate Moller from ep electrons in scattering angular range of  $0.5^\circ$ -  $0.8^\circ$
  - Three beam energies: 0.7, 1.4 and 2.1 GeV – **0.7 GeV is critical to reach  $Q^2$  value of  $4 \times 10^{-5} \text{ (GeV/c)}^2$**

# PRad-II Experimental Setup

PRad-II Experimental Setup (Side View)

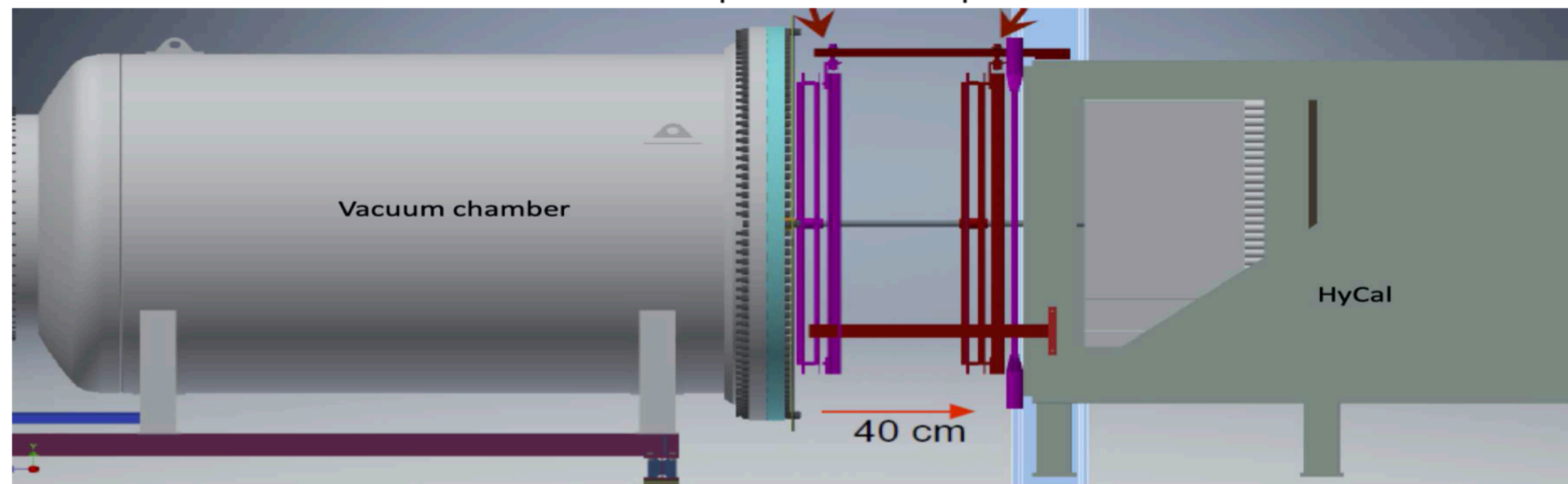
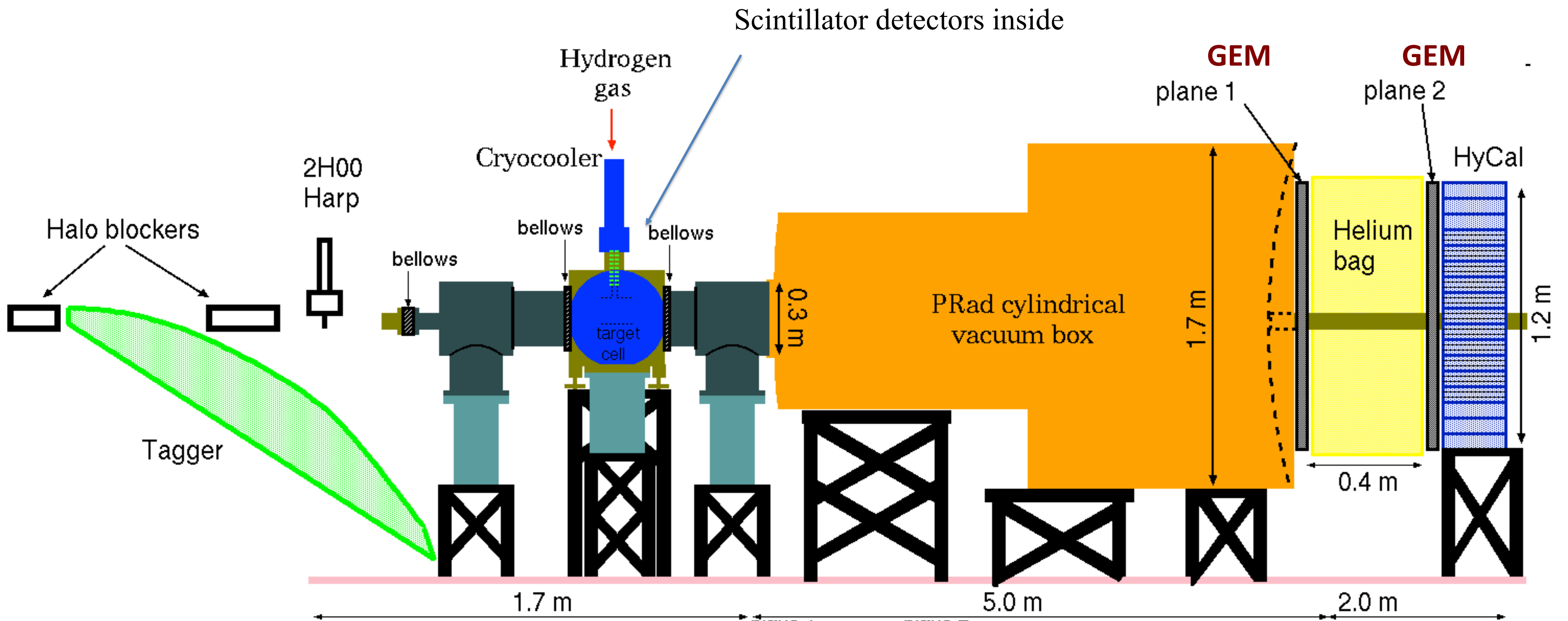

# Improvement from PRad to PRad-II

Item	PRad $\delta r_p$ [fm]	PRad-II $\delta r_p$ [fm]	Result of
Stat. uncertainty	0.0075	0.0017	More beam time and higher DAQ rate
GEM efficiency	0.0042	0.0008	2nd tracking detector
Acceptance	0.0026	0.0002	2nd tracking detector
Beam energy related	0.0022	0.0002	2nd tracking detector
Event selection	0.0070	0.0027	2nd tracking + HyCal upgrade
HyCal response	0.0029	Negligible	HyCal upgrade
Beam background	0.0039	0.0016	Better vacuum 2nd halo blocker vertex res. (2nd tracking)
Radiative correction	0.0069	0.0004	Improved calc.
Inelastic ep	0.0009	Negligible	Upgraded HyCal
$G_M^p$ parameterization	0.0006	0.0005	---
Total syst. uncertainty	0.0115	0.0032	
<b>Total uncertainty</b>	<b>0.0137</b>	<b>0.0036</b>	



**A factor of 3.8 improvement !**

# Projections for PRad-II

## Differential Cross section

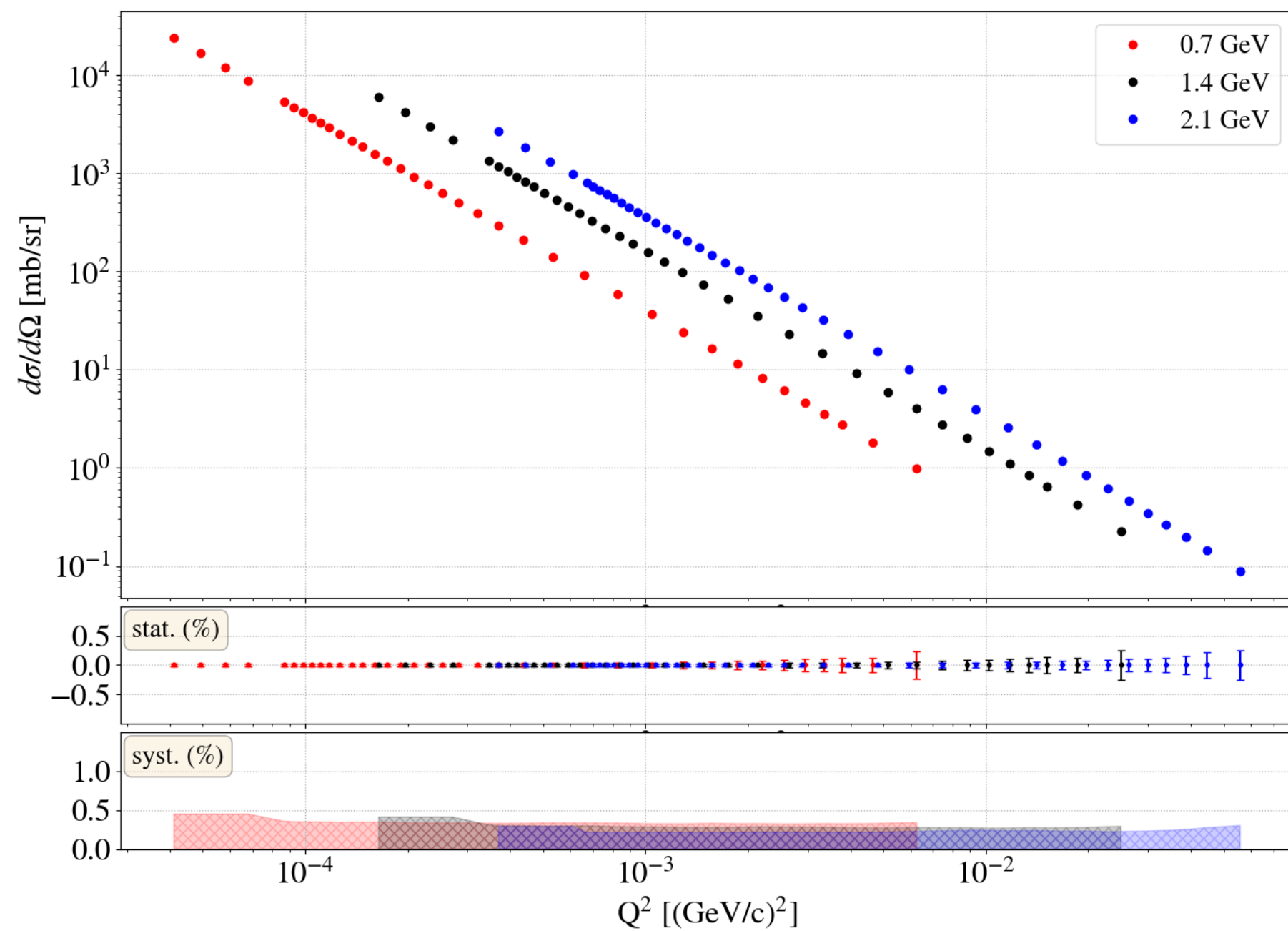

## Electric form factor

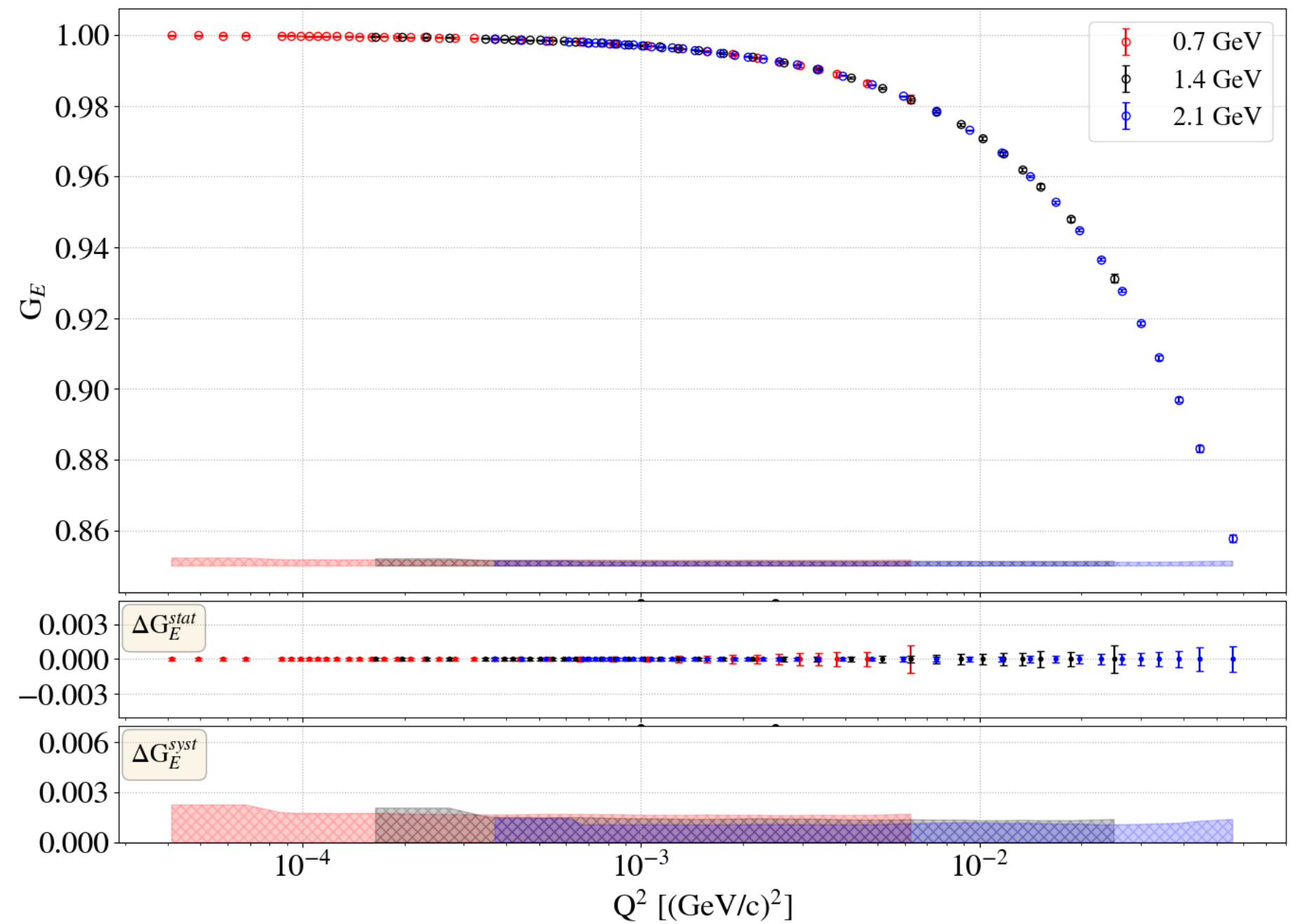

# Projections for PRad-II

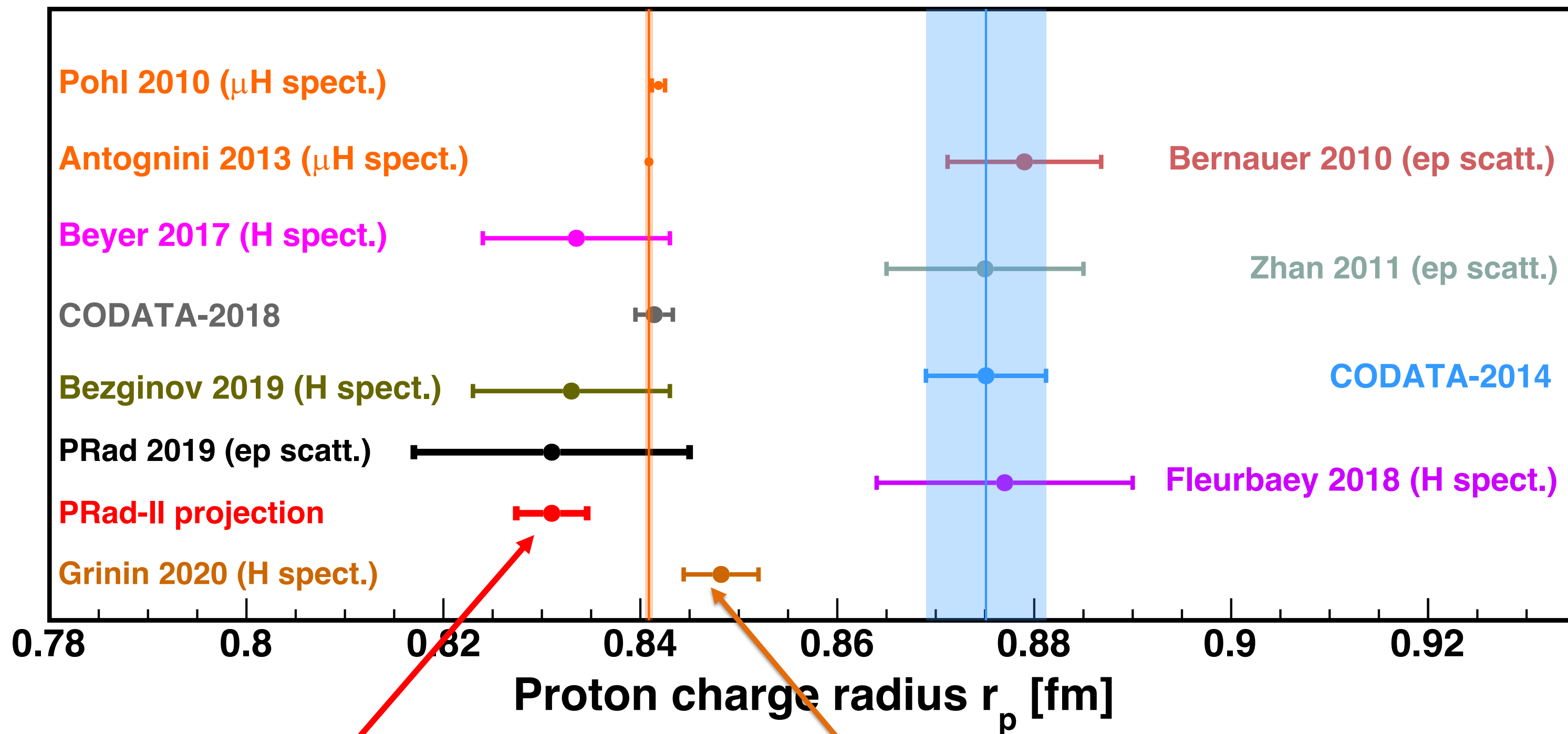

- **PRad-II: total uncertainty 0.0036 fm**

- Latest result from ordinary hydrogen spectroscopy since PAC C1 approval:

$r_p = 0.8482 \pm 0.0038$  fm  
 Grinin *et al.*, Science **370**, 1061 (2020)