

PRad Target: Target Manual and Hazard Analysis

Chris Keith, November 2015

Table of Contents

1. Target Description.....	2
1.1 General Description.....	2
1.2 Gas Supply and Distribution	3
1.3 Cooling of the Hydrogen Gas	4
1.4 Target Cell.....	4
1.5 Target Vacuum Chamber and Pumping System.....	5
2. Hazard Analysis	6
2.1 Introduction.....	6
2.2 Magnetic field hazard.....	7
2.3 Oxygen deficiency hazard	7
2.4 Power failure	8
2.5 Vacuum System Safety	8
2.6 Pressure System Safety	8
2.7 Flammable Gases	9
2.8 Cryogenic Hazards	10
3. Emergency and Interlock Response Procedures.....	12
3.1 Flammable Gas Alarm.....	12
3.2 ODH Alarm.....	12
3.3 Low Temperature Interlock.....	12
3.4 Vacuum Interlock	12
3.5 Vent Purge Interlock	12
4. Inspection and Maintenance Schedule	13
4.1 Every run.....	13
4.2 Every year	13
4.3 Other	13
A. P & I Diagram.....	14

1. Target Description

1.1 General Description

The Proton Charge Radius experiment in Hall B (PRad) utilizes a windowless, hydrogen gas jet target constructed by the Jefferson Lab Target Group (see Figure 1). Room temperature hydrogen flows through a 25 K heat exchanger attached to a mechanical cryocooler, and accumulates in a $\text{\O}50 \times 40$ mm copper target cell located within a small ($< 1 \text{ m}^3$) differentially pumped vacuum chamber. The target cell, which is suspended from the top of the vacuum chamber using a precision, 5-axis motion mechanism, has $25 \text{ }\mu\text{m}$ thick kapton covers at both ends with 4 mm orifices for the electron beam. The covers are easily detachable, so different orifice sizes can be used to examine the effects of possible beam halo. The gas is pumped from the chamber using two large turbomolecular vacuum pumps with a combined pumping speed of 5700 l/s. The gas pressure within the cell is measured by a precision capacitance manometer and is expected to be approximately 0.6 torr during the PRad experiment, giving in an areal density of about $10^{18} \text{ H}_2/\text{cm}^2$. Two additional turbo pumps are attached to the upstream and downstream ends of the vacuum chamber to maintain a beamline vacuum less than 10^{-5} torr.

Hydrogen gas is metered into the target system using a precision, room-temperature mass flow controller, while gas pumped from the chamber is exhausted outside the experimental hall via the Hall B vent header. Mechanical interlocks are used to stop the flow of hydrogen gas in the event any of vacuum, pressure, or temperature failures. These interlocks ensure that the quantity of H_2 in the chamber is always less than 30 mg.

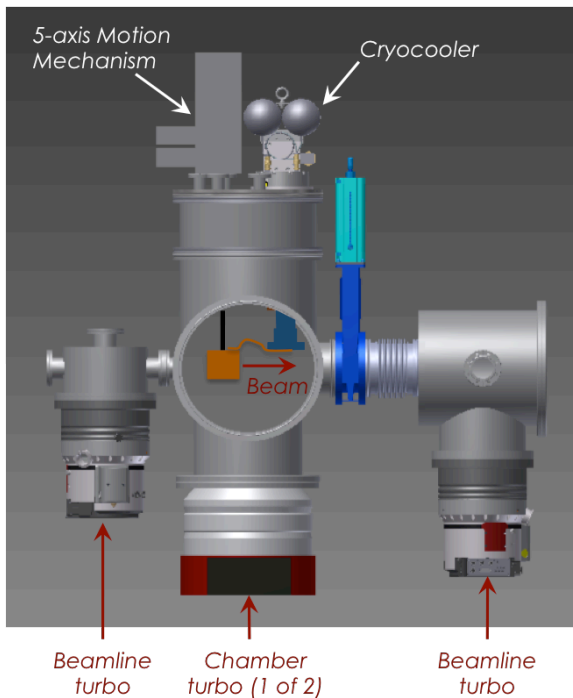

Figure 1: 3D model of the PRad windowless gas target.

1.2 Gas Supply and Distribution

Hydrogen gas is supplied to the target system from high-pressure cylinders located outside the experimental hall, in the Hall B gas shed. The cylinders are outfitted with appropriate regulators, over-pressure relief valves, and flow restrictors. Existing plumbing between the gas shed and the Hall B liquid hydrogen target is utilized to connect the cylinders to a small gas handling panel located near the target chamber (Figure 2). The panel and its connections to the target system have been designed, constructed, and tested in accordance to the appropriate ASME code of record, B31.3 (2012). All components downstream are exempted from code requirements due to pressure and temperature. If released, the gas contained in these components would have a concentration in air of approximately 0.13%, far below the Lowest Flammable Limit (LFL) for hydrogen. Gas flow to the target cell is metered by a precision mass flow meter with a maximum flow setting of 5000 sccm. Hydro-pneumatic valves HPA-1 and HPA-2 control whether the H₂ gas flows to the cell or the chamber. The latter can be used to measure scattering from background hydrogen gas outside the cell. These valves close automatically if the chamber pressure exceeds 1 torr.

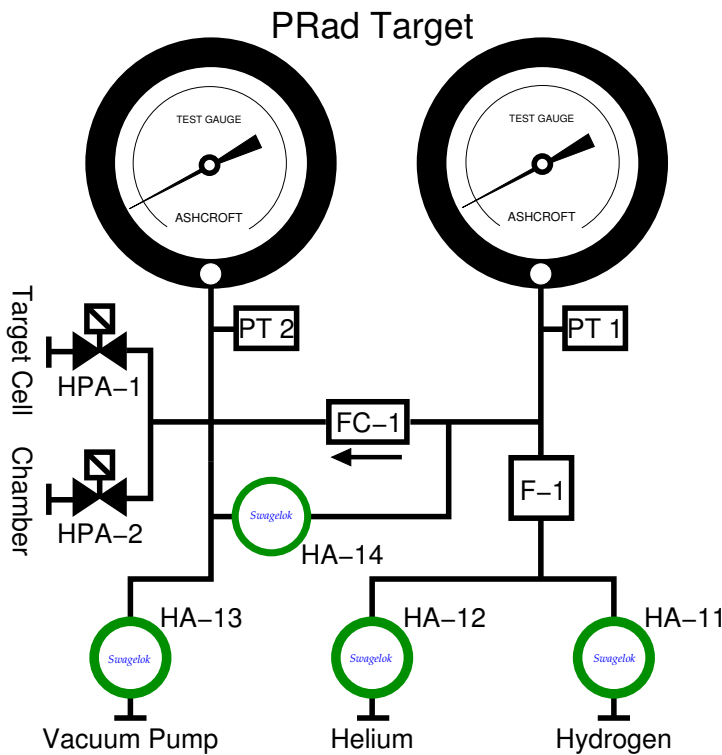

Figure 2: Schematic diagram of the PRad gas panel. HA 11—14 are hand-actuated valves. PT1 and PT2 are pressure transducers (0-60 psia). F-1 is a gas filter. FC-1 is a 0—5000 ccm mass flow controller. HPA-1 and HPA-2 are hydro/pneumatic-actuated valves.

1.3 Cooling of the Hydrogen Gas

Before the gas enters the target cell, it is cooled to a temperature of approximately 25 K using a small, two-stage pulse tube cryocooler¹ with a base temperature of 8 K and a cooling power of 14 W at 20 K. The temperature of the cryocooler is regulated using a 100 W Lake Shore Model 336 temperature controller. Normally open contacts on the controller are programmed to turn off the cryocooler if the temperature approaches the H₂ condensation temperature (22.3 K at 1 atm). Standard cernox thermometers from Lake Shore Cryotronics measure the temperature of the cryocooler, the cell body, and the gas within the cell. A copper heat shield, cooled to 80 K by the first cooling stage of the pulse tube refrigerator, surrounds the lower portion of the target system, and has large openings for the electron beam. Platinum thermometers measure the heat shield temperature.

1.4 Target Cell

A photograph of the target cell is shown in Figure 3. The body of the cell is constructed of high conductivity copper C101. Kapton windows cover the upstream and downstream ends of the cell, although each window has a small orifice at its center for the electron beam to pass through, making this target “windowless”. This orifice design is superior to the original “straw” design of the experimental proposal because it is easier to construct and align, it is less sensitive to beam halo, and will provide a more uniform gas density profile along the beam path. The 25 μm thick kapton windows, attached to the copper cell using removable aluminum window frames, will be easy to change. The cell body is cooled by the pulse tube refrigerator using a series of highly flexible copper straps. Hydrogen gas enters the cell through a small copper tube that is heat sunk to both the cryocooler and the cell body.

The cell is suspended from the chamber’s top flange using a 19 mm diameter carbon fiber tube, which in turn is attached to a 5-axis motion controller for precision alignment. A capacitance manometer, attached to the room temperature end of the tube, is used to measure the H₂ gas pressure within the cell.

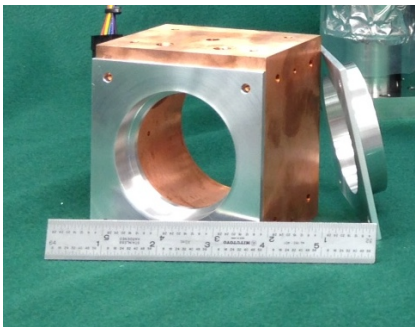

Figure 3: PRad target cell. The kapton window covers are not in place.

¹ Cryomech pulse tube refrigerator PT810.

1.5 Target Vacuum Chamber and Pumping System

The target cell and cryocooler reside inside a commercially manufactured vacuum vessel with a volume of 0.26 m³. There are no thin windows attached to the chamber. Gate valves on the upstream and downstream sides of the chamber are used to isolate it from the remainder of the PRad beam line. These valves are considered to be the boundary of the target vacuum system. A check valve on the chamber ensures that its internal pressure cannot exceed 1 psig. A 1 torr pressure switch is used to close gas panel valves HPA-1 and HPA-2 to guarantee that the quantity of H₂ gas in the chamber is always less than 0.34 standard liters or about 0.03 g.

Gas is pumped from the chamber by a total of four turbomolecular vacuum pumps. Two of these² are located under the target cell and keep the chamber pressure at approximately 5 millitorr. The other two³ are attached to the upstream and downstream sides of the chamber and are intended to differentially pump the beam line to an acceptably low vacuum of less than 10⁻⁵ torr. All pump exhaust is directed outside the experimental hall using the existing Hall B vent header. The vent header is continually purged with an inert gas, N₂. A flow switch on the purge line closes HPA-1 and HPA-2 if the purge is interrupted.

² Pfeiffer HiPace 3200

³ Pfeiffer HiPace 2300

2. Hazard Analysis

2.1 Introduction

The tables below are copied from the Jefferson Lab EH&S manual, *Appendix T3: Risk Code Assignment*. Mitigation is required for hazards deemed to have a risk code greater than 2. For the PRad cryotarget, the highest risk code before mitigation is 3. The highest risk code after mitigation is 1.

Table 1: Risk Code Assignment

Consequence Level	H	1	3	4	4
	M	1	2	3	4
	L	N*	1	2	3
	EL	N*	N*	1	1
		EL	L	M	H
Probability Level (Estimated likelihood per full-time active person)					

*Negligible Risk

Consequence Level	Severity	Property Loss
High (H)	Serious impact on-site. May cause death or loss of facility operation. Major impact on the environment.	> \$100,000
Medium (M)	Significant impact on-site. May cause severe injury, severe occupational illness to personnel, major damage to the facility operation, or impact on the environment.	> \$50,000
Low (L)	Minor impact on-site. May cause minor injury, minor occupational illness, or minor impact on the environment.	> \$500
Extremely Low (EL)	Insignificant injury, occupational illness, or impact on the environment.	< \$500

Probability Level	Description*	Estimated Probability of Incident Occurrence per Year
High (H)	An incident is likely to occur several times during task.	$> 10^{-1}$
Medium (M)	An incident may occur during the task.	10^{-2} to 10^{-1}
Low (L)	Probability of an incident occurring is unlikely to happen during the task.	10^{-4} to 10^{-2}
Extremely Low (EL)	Probability of an incident occurring is extremely unlikely to happen during the task.	10^{-6} to 10^{-4}

* Assuming a person performed the task 2000 hours per year.

Table 1. Risk Code assignment tables, from the Jefferson Lab EH&S manual.

2.2 Magnetic field hazard

There are no magnetic fields generated by the target system.

Consequence Level: Medium

Probability Level: Extremely Low

Risk Code before Mitigation: Negligible

Mitigation: na

Risk Code after Mitigation: Negligible

2.3 Oxygen deficiency hazard

The target utilizes hydrogen gas as the target material, while the cryocooler uses helium gas as a coolant. Therefore, a potential ODH risk is present. The total inventory of the H₂ gas in the target system is about 1 liter, while the volume of helium gas necessary to operate the PTR is 81 liters⁴. The volume of Hall B is approximately 1.2×10^7 liters (437,500 ft³). Release of the target's hydrogen/helium gases in this area would be completely negligible, decreasing the Hall B oxygen levels by less than 0.001%. Therefore, the gas jet target does not impact the ODH classification of this location.

High-pressure cylinders of hydrogen, each containing approximately 8000 standard liters, will be used to supply gas to the target. These cylinders will be located in the Hall B gas shed and connected to the target gas panel using existing lines in Hall B.

Consequence Level: Medium

Probability Level: Low

Risk Code before Mitigation: 2

Mitigation: Minimization of ODH gases.

⁴ Cryomech, Inc. private communication.

2.4 Power failure

A few control electronics will be attached to an uninterruptable power supply (UPS), including the LS336 temperature controller and scattering chamber vacuum readout. This is primarily for monitoring reasons, because the system is designed to be intrinsically safe in the event of power outages. In all cases, the cryocooler simply turns off and the target slowly warms to room temperature. The (Normally Closed) valves HPA-1 and HPA-2 that provides hydrogen gas to the target close, and the turbo pumps spin down.

Consequence Level: Low

Probability Level: Medium

Risk Code before Mitigation: 2

Mitigation: Cryocooler shuts off, gas valves close.

Risk Code after Mitigation: 1

2.5 Vacuum System Safety

The volume of the vacuum chamber is approximately 0.26 m³, representing a stored energy of 26 kJ. This is less than the 100 kJ limit imposed by the Jefferson Lab EH&S manual for buckling analysis. It is also exempt from Code welding/brazing requirements. There are no thin windows on the chamber. A pressure switch on the chamber will automatically shut off hydrogen gas to the chamber at 1 torr. A check valve with Cv=0.66 is installed on the chamber to prevent overpressure, should the switch fail.

Consequence Level: Medium

Probability Level: Low

Risk Code before Mitigation: 2

Mitigation: Minimize chamber volume, no thin windows

Risk Code after Mitigation: 1

2.6 Pressure System Safety

Two new components in the target system fall under the purview of pressure systems safety:

1. The gas handling panel in the experimental hall,
2. Chilled water lines between a pair of water chillers and the vacuum pumps and the cryocooler compressor.

The gas panel is constructed in accordance with ASME B31.3 (2012). It is supplied with gas from a standard H₂ cylinder, with regulator, located in the Hall B gas pad using existing pipes between the pad and the experimental hall. Relief valves located at the exit of the regulator ensure a maximum gas pressure of 30 psig in the gas handling system.

Chilled water is supplied to the turbo pumps and cryocooler compressor from a pair of NESLAB ThermoFlex 10000 chillers, each with a maximum outlet pressure of 60 psi. All fittings, lines and other components in the chilled water system are rated to a minimum

working pressure of at least 90 psig. The chilled water system is now considered a low hazard system (stored energy less than 1000 ft-lbf) and is exempted from the pressure system program requirements now in effect. Nonetheless, it was constructed to and is in compliance with ASME B31.3 (2012) Cat D.

Complete details concerning the pressure system specific engineering of the PRad target system can be located in the DocuShare directory:

[Facilities > Engineering > Pressure Systems > Pressure Systems Directory \(New\) > PS-TGT-14-001 PRad Target](#)

Consequence Level: Medium

Probability Level: Low

Risk Code before Mitigation: 2

Mitigation: Design and construction in compliance with relevant ASME pressure system codes. Routine inspection, testing, and replacement of system components.

Risk Code after Mitigation: 1

2.7 Flammable Gases

The PRad target utilizes hydrogen gas, which is flammable in air over a range of concentrations from 4% to 75%, by volume. The quantity of hydrogen gas inside the PRad target system (comprising the gas panel, internal piping and target cell, and target chamber) is about 1 standard liter, or 0.09 grams. Therefore the system may be classified as a Class 0 risk ($Q < 0.6\text{kg}$). All potential ignition sources on the gas panel (pressure transducers and flow controllers) meet CLASS I DIV 1 GROUPS A, B, C, & D standards. All thermometers inside the chamber operate at very low voltage and currents⁵. A 100 W heater is used to control the cryocooler temperature at about 25 K. It is automatically de-energized by the 1 torr pressure switch on the scattering chamber. Therefore the maximum quantity of H₂ that can be in contact with this potential ignition source is only 26 mg. The chamber will be evacuated of hydrogen and purged with an inert gas such as nitrogen or argon before it opened to air.

A standard cylinder of hydrogen (approx. 8200 standard liters) is used to provide a constant supply of H₂ gas to the target system. This cylinder is located in the Hall B gas shed, away from any ignition sources (10 feet). It is capped when not in use and properly labeled "Danger-Flammable Gas". The lines leading from the cylinder to the target installation have been used for several years for the Hall B liquid hydrogen target. Any necessary extensions to these lines will be constructed in accordance to ASME 31.3 (2012).

All pump exhausts and relief lines from the target are attached to the same Hall B vent header that has been utilized for the Hall B liquid hydrogen target. A steady purge of inert N₂ gas is used to prevent a flammable mixture in the vent. Any necessary piping

⁵ Typical excitations are 10 μA and 10 mV for a 1 k Ω sensor.

between the PRad target installation and the vent header will be constructed in accordance to ASME 31.3 (2012). The vent header will be properly labeled “Danger – Flammable Gas”. The Hall B flammable gas monitoring system will be in operation throughout the PRad experiment.

Consequence Level: High

Probability Level: Low

Risk Code before Mitigation: 3

Mitigation: Flammable gas and hydrogen monitoring. Non-sparking tools.

Minimization of ignition sources. Compliance with ASME 31.12 for hydrogen piping. Proper posting of “Flammable Gas Area”. Inerting system prior to maintenance and repair. Leak test system before operating system. Follow approved procedures during operation.

Risk Code after Mitigation: 1

2.8 Cryogenic Hazards

No cold portions of the PRad target are accessible by personnel. Due to the windowless nature of the target, no condensed cryogenic fluids can be accumulated within its volume, and the total quantity of vapor is only about 0.03 g.

Cernox thermometers monitor the temperature of the fluid at numerous locations, including the cryocooler cold head, the copper target cell, and the vapor inside the cell itself. The temperature of the cold head is regulated at about 25 K using a Lake Shore Model 336 temperature controller. Normally open contacts on the controller turn off the cryocooler before the temperature reaches the condensation point of H₂, about 22.3 K at 1 atm.

Frozen contaminants in the H₂ gas could impede or stop the flow of gas to the target cell. However this does not represent a hazard, as no condensed fluids exist in the system. Nevertheless precautions are made to ensure the purity of the target gas for the PRad experiment. Detailed gas handling procedures will be utilized to ensure that no gases other than hydrogen (or helium, for purges) are present in the system. Only high purity hydrogen gas (research or scientific grade) will be used in the target, and this will be introduced into the cell through a purifier⁶ installed on the gas panel for further removal of water and oil.

Consequence Level: Medium

Probability Level: Medium

Risk Code before Mitigation: 3

Mitigation: Temperature and pressure alarms. Temperature interlocks.

Minimization of target gas and volume. Documented gas handling procedures.

Risk Code after Mitigation: 1

⁶ Matheson 450B with 13X molecular sieve

3. Emergency and Interlock Response Procedures

3.1 Flammable Gas Alarm

If the flammable gas alarm goes off, notify others, press the KILL switch on the target control panel, and evacuate the area.

3.2 ODH Alarm

If the ODH alarm sounds, notify others, press the KILL switch on the target control panel, and evacuate the area.

3.3 Low Temperature Interlock

The Lake Shore 336 temperature controller has normally open relays that will turn off the cryocooler if the temperature of the target gets too close to the condensation point of hydrogen. The system will slowly warm. This is not considered an emergency. Contact the Target Expert.

3.4 Vacuum Interlock

A 1 torr vacuum switch will close electric valves HPA-1 and HPA-2 located on the target gas panel. This is not considered an emergency. Contact the Target Expert.

3.5 Vent Purge Interlock

A pressure switch is installed on the hydrogen vent line to ensure that it is adequately purged with an inert gas such as nitrogen. An alarm in the counting house will sound if this switch energizes. Check that the purge line is properly connected and that gas is flowing into the vent. If it is not, contact the Hall B work coordinator. If gas is flowing but the switch is still energized, contact the Target Expert.

4. Inspection and Maintenance Schedule

4.1 Every run

- Visually inspect all process piping.
- Leak check all process piping.
- Confirm operation of electronic monitoring and control hardware.
- Confirm all thermometer readouts (~295 K at room temperature).
- Confirm operation of pressure switches PAH1.
- Confirm operation of check valve CV1.
- Zero pressure transducers PI1 and PI2 and calibrate against their corresponding pressure gauges.
- Inspect filter/purifier element FP1.
- Review and if necessary update the safety and operation manuals for the PRad target.
- Visually inspect vacuum pumps.
- Visually inspect the PTR, its compressor and Aeroquip connections.
- Visually inspect water-cooling piping for PTR compressor and turbo pumps.
- Confirm operation of flow switch for PTR compressor.
- Confirm PTR helium charge.

4.2 Every year

- Have pressure gauges PI1 and PI2 calibrated by a vendor certified to JLab standards.

4.3 Other

- Inspect/test all relief and check valves in the system every two years
- Replace adsorber in PRT compressor after 20,000 hours of operation (consult PRT manual).

A. P & I Diagram

