

2014 Version: Jefferson Lab Hall B Standard Equipment Manual

Info Level 4

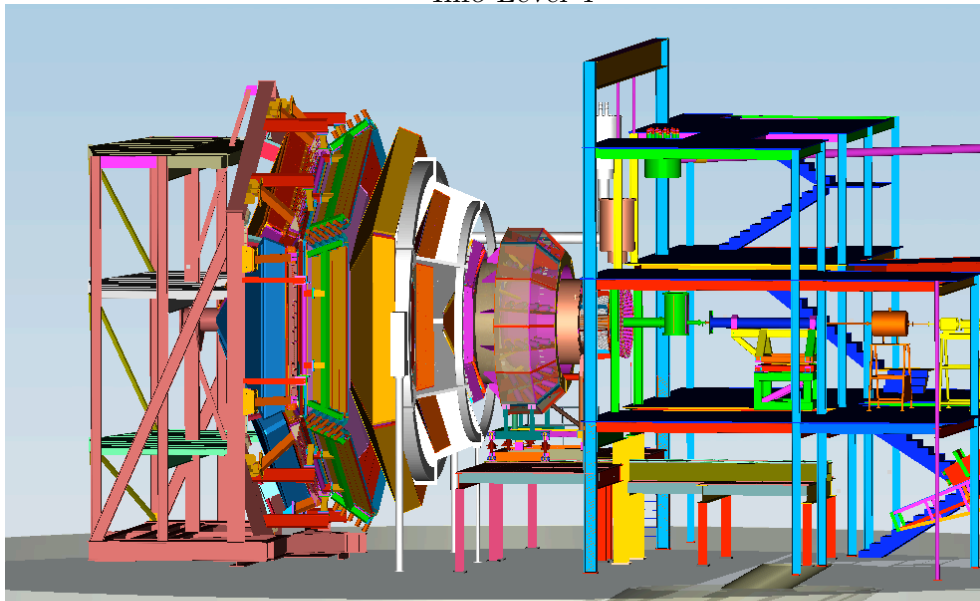

The Hall B Collaboration
*Editor: H. Avakian and V. Burkert*¹

October 27, 2015

¹Thomas Jefferson National Accelerator Facility

Contents

1	Hall Specific Equipment	4
1.1	Overview	4
1.2	Checking Tie-in To Machine Fast Shutdown System	4
2	General Description	5
2.1	Introduction	5
I	Beamline	6
2.1.1	Hazards	7
2.1.2	Mitigations	7
2.1.3	Responsible Personnel	8
II	PRad Detector Package	9
3	Target System	10
3.0.4	Hazards	10
3.0.5	Mitigations	10
3.0.6	Responsible personnel	10
4	Hall B Vacuum System	12
4.0.7	Hazards	12
4.0.8	Mitigations	12
4.0.9	Responsible personnel	12
4.1	GEM Tracker	13
4.1.1	Hazards	13
4.1.2	Mitigations	13
4.1.3	Responsible personnel	14
4.2	Electromagnetic Calorimeter	14
4.2.1	Hazards	14
4.2.2	Mitigations	14
4.2.3	Responsible personnel	15
4.3	CLAS12 Construction work	15

4.3.1	Hazards	15
4.3.2	Mitigations	15
4.3.3	Responsible Personnel	15
III	Slow Controls	17
5	Overview	18
5.1	System's Components	18
5.2	Operating Procedures	18
5.3	AlarmHandler	18
5.4	StripTool	19
5.5	Snapshot	19
5.6	Troubleshooting Procedures	19
5.6.1	Authorized Personnel	19
IV	Data Acquisition and Trigger	20
6	Spectrometer Data Acquisition	21
6.1	General Computer Information	21
6.2	DAQ checklist	21
6.3	Beginning of Experiment Checkout	22
6.4	Running CODA	22
6.4.1	Some Frequently Asked Questions about DAQ	22
6.4.2	Quick Resets	23
6.4.3	Cold Start of CODA	23
6.4.4	Recovering from a Reboot of Workstation	23
6.5	Electronic Logbook and Beam Accounting	24
6.6	Authorized Personnel	24
7	Trigger Hardware and Software	25
7.1	Overview	25
7.2	Components	25
7.2.1	Authorized Personnel	25
8	Online Analysis, Data Checks	27
8.0.2	Scaler Display and Scaler Events	27
8.1	Analysis using CLAS12 Monitoring	27
8.1.1	Responsible Personnel	27

<i>CONTENTS</i>	3
V Offline Analysis Software	28
9 CLAS12 Offline Analysis	29

Chapter 1

Hall Specific Equipment

1.1 Overview

The following Hall B subsystems are considered part of the experimental endstation equipment for running the Proton Charge Radius (PRad) experiment engineering run. Many of these subsystems impose similar hazards, such as those induced by high voltage systems and vacuum systems. Note that a specific sub-system may have many unique hazards associated with it. For each major system, the hazards, mitigations, and responsible personnel are noted.

The material in this chapter is a subset of the material in the full Hall B operations manual and is only intended to familiarize people with the hazards and responsible personnel for these systems. It in no way should be taken as sufficient information to use or operate this equipment.

1.2 Checking Tie-in To Machine Fast Shutdown System

In order to make sure that hall equipment that should be tied into the machine fast shutdown (FSD) system has been properly checked, the hall work coordinator must be notified by e-mail prior to the end of each installation period by the system owner that the checks have been performed in conjunction with accelerator operations (i.e. checking that equipment's signals will in fact cause an FSD). These notifications will be noted in the work coordinator's final check-list as having been done. System owners are responsible for notifying the work coordinator that their system has an FSD tie-in so it can be added to the check-list.

Chapter 2

General Description ¹

2.1 Introduction

¹Authors: S.Stepanyan stepanya@jlab.org

Part I
Beamline

The control and measurement equipment along the Hall B beamline consists of various elements necessary to transport beam with required specifications onto the production target and the beam dump, and simultaneously measure the properties of the beam relevant to the successful implementation of the physics program in Hall B.

The beamline in the Hall provides the interface between the CEBAF accelerator and the experimental hall. All work on the beamline must be coordinated with both physics division and accelerator division in order to ensure safe and reliable transport of the electron beam to the dump.

2.1.1 Hazards

Along the beamline various hazards can be found. These include radiation areas, vacuum windows, high voltage, and magnetic fields.

2.1.2 Mitigations

All magnets (dipoles, quadrupoles, sextuples, beam correctors) and beam diagnostic devices (BPMs, scanners, beam loss monitors, viewers) necessary to transport and monitor the beam are controlled by Machine Control Center (MCC) through EPICS [1], except for specific elements which are addressed in the subsequent sections. The detailed safety operational procedures for the Hall B beamline should be essentially the same as the one for the CEBAF machine and beamline.

Personnel who need to work near or around the beamline should keep in mind the potential hazards:

- Radiation "Hot Spots" - marked by ARM of RadCon personnel,
- Vacuum in beamline tubes and other vessels,
- Thin windowed vacuum enclosures (e.g. the scattering chamber),
- Electric power hazards in the vicinity of magnets, and
- Conventional hazards (fall hazard, crane hazard, etc.).

These hazards are noted by signs and the most hazardous areas along the beamline are roped off to restrict access when operational (e.g. around the PRad target area). Signs are posted by RadCon for any hot spots. Survey of the beamline and around it will be performed before work is done on the beam line or around. The connection of leads to magnets have plastic covers for electrical safety. Any work around the magnets will require de-energizing the magnets. Energized magnets are noted by red flashing beacons. Any work on the magnets requires the "Lock and Tag" procedures [2].

Additional safety information is available in the following documents:

- EH&S Manual [2];
- PSS Description Document [3]
- Accelerator Operations Directive [4];

2.1.3 Responsible Personnel

The beamline requires both accelerator and physics personnel to maintain and operate. It is very important that both groups stay in contact with each other to coordinate any work on the Hall B beamline. The authorized personnel is shown in table 2.1.

Name (first,last)	Dept.	Call [5]		e-mail	Comment
		Tel	Pager		
F.-X. Girod	Hall-B	6002		fxgirod@jlab.org	<i>1st Contact</i>
Stepan Stepanyan	Hall-B	7196		stepanya@jlab.org	<i>2nd Contact</i>
Michael Tiefenback	Accel.	7430	757-438-4523+	tiefen@jlab.org	<i>Contact to Hall-B</i>
Hari Areti	Accel.	7187	584-	areti@jlab.org	<i>Contact to Physics</i>

Table 2.1: Hall B beamline: authorized personnel.

Part II

PRad Detector Package

Chapter 3

Target System

The PRad target system consists of a thin windowless cell hung from a linear feedthrough. Target position is remotely adjustable vertically allowing it to be inserted into the beam.

3.0.4 Hazards

There are hazards related to moving the target frame into the beam or overheating the target foils. The stepping motor linear actuator will be operated using EPICS controls. The GUI for operation of the target will have preset coordinates for each target foil. The tungsten targets are intended to operate with beam currents up to 500 nA, which produce strong local heating. The strength of tungsten drops by an order of magnitude with temperature increases in the range of 1000 C. In addition, the material re-crystallizes above this range, which increases the tendency for cracking where thermal expansion has caused temporary dimpling.

3.0.5 Mitigations

There will be limit switches (hard stops) that will prevent the motion of the target ladder outside of allowed range if EPICS set values are wrong. To keep the temperature rise less than about 1000 degrees, we adjust the optics to produce an adequately large beam spot and limit the maximum current incident on the target. There will be overall beam current limit of 500 nA for the experiment.

3.0.6 Responsible personnel

The target system will be maintained by the Hall B engineering group.

Name	Dept.	Phone	email	Comments
Tech-on-call	Hall-B			1st contact
D. Tilles	Hall-B		tilles@jlab.org	2nd contact
C. Keith	JLab Target Group		ckeith@jlab.org	contact

Table 3.1: Personnel responsible for the target.

Chapter 4

Hall B Vacuum System

1

The Hall B vacuum system consists of three segments, all interconnected. The beam transport line consisting of 1.5 to 2.5 inch beam pipes, the Hall B tagger magnet vacuum chamber, and a large $\sim 5\text{m}$ long vacuum chambers extending from the target to the PRad detector system. Only the tagger vacuum chamber has a large window, 8 inches over 30 ft Kevlar-Mylar composite window. There is a 1.7m diameter 63 mil Al. window at the end of the vacuum system, before the PRad detectors. The vacuum in the system is provided by a set of rough, turbo, and ion pumps and it is maintained at the level of better than 10^{-5} Torr.

4.0.7 Hazards

Hazards associated with the vacuum system are due to rapid decompression in case of a window failure. Loud noise can cause hearing loss. Also, there is a hazard related to the GEM chamber being sucked into the vacuum chamber in case of a window failure.

4.0.8 Mitigations

All personnel working in the vicinity of the tagger vacuum chamber window are required to wear ear protection. Warning signs must be posted in that area. To mitigate a possible

4.0.9 Responsible personnel

The vacuum system will be maintained by the Hall B engineering group. The au-

Name (first,last)	Dept.	Call [5]		e-mail	Comment
		Tel	Pager		
Tech-on-Call	Hall-B				<i>1st Contact</i>
Doug Tilles	Hall-B	7566		tilles@jlab.org	<i>2nd Contact</i>

Table 4.1: Hall B beamline: authorized personnel.

thorized personnel is shown in table 4.1.

4.1 GEM Tracker

The Gas Electron Multiplier (GEM) tracker consists of a pair of large area $1.5 \text{ m} \times 0.6 \text{ m}$ three layer ionization chambers.

4.1.1 Hazards

Hazards to personnel include the high voltage which biases the sensors, and the low current which powers the readout electronics.

Hazards to the SVT itself include mechanical damage, radiation damage, and overheating. Hazards to the vacuum system could arise from excessive SVT outgassing or coolant leaks. SVT mechanical damage could occur if the top sensors are accidentally driven into the bottom sensors.

Radiation damage could occur in the SVT if the sensors are driven too close to the beam, the beam moves into the sensors, the beam interacts upstream to produce excessive radiation, or excessive beam currents create more radiation than can be tolerated.

Overheating can occur in the SVT if the cooling system is performing inadequately or if a cooling system leak develops.

4.1.2 Mitigations

Hazards to personnel are mitigated by turning off HV and LV power before disconnecting cables or working on the sensors and internal electronics. Hazards to the Hall B vacuum system have been mitigated by extensive testing of all components to ensure low-outgassing rates, construction of the SVT and electronics in a clean room, and tests of the cooling system to high pressures to prove leak-tightness. The coolant used, water glycol, would not cause irreparable damage to the vacuum system if a leak occurred. If the system pressure increases, the coolant supply is halted.

Possible mechanical damage has been mitigated by designing the channels which hold the sensors to touch before any modules would touch. Software limits and limit switches on the motion controllers also prevent the sensors from moving into each other or too close to the beam.

¹Authors: S. Stepanyan stepanya@jlab.org

Radiation damage from the beams is mitigated in several steps. First, beam size and halo must conform to beam requirements before beams are passed through the detector. Second, the beams are centered between the top and bottom sections of the SVT. Third, an upstream collimator is aligned with the "centered" beam position to intercept the beam if it moves off nominal position. Fourth, beam halo monitors sense a rise in backgrounds if the beam moves off nominal position, activating the FSD and removing the power permissive to the SVT. Fifth, precision movers position the SVT layers precise and safe distances from the beam. Finally, beam currents and target thicknesses are carefully chosen to avoid over-radiating the silicon sensors.

Overheating is mitigated by requiring good coolant flow, proper coolant temperature, good vacuum (assuring no coolant leakage), and sensor temperature in range in the interlock for SVT HV and LV power.

4.1.3 Responsible personnel

Individuals responsible for the system are:

Name	Dept.	Phone	email	Comments
Tim Nelson	SLAC			First contact
Omar Moreno	UCSC			Contact
Sho Uemura	SLAC			Contact
Per Hansson	SLAC			Contact

Table 4.2: Personnel responsible for the silicon tracker.

4.2 Electromagnetic Calorimeter

The Electromagnetic Calorimeter (HyCal) consists of xx lead-tungstate (PbWO_4) crystals with PMT readout and yy Lead-glass crystals with PMT readout enclosed inside a temperature controlled enclosure.

4.2.1 Hazards

Hazards associated with this device are electrical shock or damage to the APDs if the enclosure is opened with the HV on. There is also hazard associated with coolant leak that may damage preamplifier boards.

4.2.2 Mitigations

Whenever any work has to be done on the calorimeter, whether it will be opened or not, HV and LV must be turned off. Turn chiller off if enclosure will be opened for maintenance. Any large (more than couple of degrees in C) must be investigated to make sure that there are no leaks.

4.2.3 Responsible personnel

The authorized personnel is shown in table 4.3.

Name (first,last)	Dept.	Call [5]		e-mail	Comment
		Tel	Pager		
Stepan Stepanyan	Hall-B	7196		stepanya@jlab.org	<i>1st Contact</i>
Raphael Dupre	ORSAY	7252		dupre@ipno.in2p3.fr	<i>2nd Contact</i>

Table 4.3: HPS calorimeter: authorized personnel.

4.3 CLAS12 Construction work

The main 12 GeV activity in Hall-B during the PRad run will be assembly of the CLAS12 Torus magnet. Beam running would occur during evenings, nights, and weekends or during other periods when it would not conflict with the regularly scheduled assembly of the CLAS12 Torus coils.

4.3.1 Hazards

There are no personal hazards associated with the running over evenings, nights, and weekends, and continue with torus assembly during the normal work hours. The only hazard is possible delays of start of the torus work after beam the delivery due to possible activation of beamline parts close to the torus assembly fixtures.

4.3.2 Mitigations

Every time Hall will switch from beam running to torus assembly, a fully survey of the hall will be conducted and Hall will be brought to "Restricted Access". Normally this will happen very early in the morning of work day (6am). If elevated radiation near torus assembly fixtures are found, work on torus must be delayed until conditions are acceptable.

However, we do not expect any excess radiation in the Hall or activation of any beam line components near the torus assembly area. The PRad target is located ~ 10 meters upstream of the assembly area and it is a very thin gas flow target. Only tuned electron beam with less than 10 nA current, will be transported in vacuum through hall to the target. If beam conditions are not acceptable, which may result excess radiation, beam tune will be performed. Every time beam tune is required the Hall-B tagger magnet will be energized and beam will be dumped on the Hall-B tagger dump, shielded hole in the floor ~ 15 meters upstream of the torus assembly area.

4.3.3 Responsible Personnel

Individuals responsible for the coordination of the torus assembly and PRad run:

Name	Dept.	Phone	email	Comments
PDL	Hall-B			1nd contact
E. Pasyuk	Hall-B		stepanya@jlab.org	contact
D. Kashy	Hall-B		Kashy@jlab.org	contact

Table 4.4: Personnel responsible for coordination of the PRad run and the torus assembly.

Part III
Slow Controls

Chapter 5

Overview ¹

The basic components of the system are:

- Input/Output Controllers (IOCs) - VME systems
- Operator Interfaces (OPI) - Computers capable of executing EPICS tools to interact with the IOCs. Some of the most used tools in Hall B are StripTools allowing to monitor the behavior of one or more signals as a function of time.

5.1 System's Components

The tasks assigned to the various IOCs are,
ioch-1 Beam current/position monitors.
ioch-2 Beam helicity asymmetry.....

5.2 Operating Procedures

Log into the Hall B control system through one of the computers....
To start any of these applications, use

5.3 AlarmHandler

The “AlarmHandler” notifies the user when either a signal being monitored is outside some pre-defined limits or communication with the IOC in which the signal resides has been lost. “AlarmHandler” will only detect an abnormal signal condition if the signal is included in the application configuration file and, the corresponding IOC database record is set to produce an alarm condition.

¹Authors: K. Livingston kliv@jlab.org

5.4 StripTool

Strip Tool plots a real-time strip chart of the values of one or more signals. It is useful to monitor data trends. A detail description of the options and operation of this application can be found in the Strip Tool Users Guide² with one difference; the version used by Hall A does not have a “print” function. To print a strip chart use the application “Snapshot” described below.

5.5 Snapshot

Snapshot refers to a KDE desktop application (ksnapshot) which allows to grab an image of either the whole screen or an individual window. The image can then be sent to a printer or stored on disk.

5.6 Troubleshooting Procedures

The status of most IOCs can be seen by opening the

Rebooting of the IOCs is accomplished in several ways depending on the specific IOC.

5.6.1 Authorized Personnel

The authorized personnel is shown in table 5.1.

Name (first,last)	Dept.	Call [5]		e-mail	Comment
		Tel	Pager		
Ken Livingston	Hall-B/Glasgow	XXX		kliv@jlab.org	

Table 5.1: Slow controls: authorized personnel.

²<http://www.aps.anl.gov/epics/extensions/StripTool/index.php>

Part IV

Data Acquisition and Trigger

Chapter 6

Spectrometer Data Acquisition ¹

The Hall B data acquisition uses CODA [6] (CEBAF Online Data Acquisition), a toolkit developed at Jefferson Lab by the Data Acquisition Group. Up to date information about the Hall B DAQ is kept at ².

We typically run with

The trigger supervisor is a custom-made module built by the data acquisition group. Its functions are to synchronize the readout crates, to administer the deadtime logic of the entire system, and to prescale various trigger inputs. We have a trigger supervisor...

The trigger management software is described in the Trigger chapter.

6.1 General Computer Information

In the counting room we have various computers for DAQ, analysis, and controls. The controls subnet is the responsibility of

6.2 DAQ checklist

Things to check before experiment starts

1.
2. raster cabling
3. check portservers
4. check reset
5. check trigger latch is connected
6. helicity if needed

¹Authors: S.Boyarinov boiarino@jlab.org

²http://clasweb.jlab.org/equipment/daq/daq_trig.html

7. scalers
8. synchronization time stamp

6.3 Beginning of Experiment Checkout

This section describes the checkout of DAQ and trigger needed before an experiment can start.

1. First ensure that all the fastbus, VME, CAMAC, and NIM crates are powered on.
2. Make sure the HV is on for all detectors and that the values are normal.
3. Start the scalers display following the instructions below and check that the rates from detectors are normal.
4. Startup CODA using the directions below and start a run. With the trigger downloaded and the HV on, you are taking cosmics data, typically at a rate of 3 Hz per spectrometer.

6.4 Running CODA

This section describes how to run CODA for the CLAS12 DAQ.

Here is how to start and stop a run. Normally, when you come on shift, runcontrol will be running. If not, see the section on “Cold Start” below. To start and stop runs, push the buttons “Start Run” and “End Run” in the runcontrol GUI. To change configurations use the “Run Type” button. If you have been running you will first have to push the “Abort” button before you can change the run type. Typically the configurations you want are the following.

A note about pedestal runs. They have the exclusive purpose of obtaining pedestals used for pedestal suppression. For details about what is done and hints for getting pedestals for analysis (which does not want the PEDRUN result), see [/ped/README](#).

6.4.1 Some Frequently Asked Questions about DAQ

- *Q: Where is the data ?* Use a command

Files are archived automatically to tape in the MSS tape silo. Two tape copies are made. Data are purged from disk automatically. Users should *never* attempt to copy, move, or erase data.

- *Q: How to adjust prescale factors ?* Edit the file
- *Q: What is the deadtime ?* The deadtime is displayed in

- *Q: Where are the crates ?* Fastbus crates ROCXXX are ...
- *Q: Why is the deadtime so high ? (and related)* Search for answers among the following....

6.4.2 Quick Resets

Problems with CODA can usually be solved with a simple reset. If not, try a Cold Start (see next section). Do not waste an hour of beam time on resets; if they fail, call an expert. The expert claims he can restart CODA 90% of the time within 10 minutes.

If a ROC (ReadOut Controller, or crate) is hung up, reboot by going the workspace “Components” and typing If this doesn’t work, try pressing the reset button which is on the “Crate Resets” section of the

6.4.3 Cold Start of CODA

If CODA is not running, or if it gets hung up, you can do a cold start. Frequently a subset of these steps is sufficient to recover from a hangup, but it takes some experience to realize the minimum of steps that are necessary, so the simplest thing is to do them all, which takes a few minutes.

- Make sure the fastbus and VME crates are running. The crates are usually known by
- Start runcontrol and the other necessary processes by typing
- In runcontrol, press the “Connect” button. Wait 5 seconds and press “Run Types”. After configure and before download, press the “Reset” button in the upper left corner. Choose the run type from the dialog box (see section on Running CODA for descriptions of run types).
- After you configure and download the Run Type, you can “Start Run” to start a new run.

6.4.4 Recovering from a Reboot of Workstation

If the workstation from which you are running CODA was rebooted, here is how to recover DAQ. Login as the relevant account, which is usually a-onl for 1-DAQ operation. Passwords for the online accounts should be available on a paper on the wall in the counting room, or ask the run coordinator. In the workspace for “Components” telnet into all the ROCs. If the x-terms windows are not available, type

6.5 Electronic Logbook and Beam Accounting

Two tools are available for logging information by the shift workers: (1) The Electronic Logbook, and (2) The Hall Beam–Time Accounting Table.

The electronic logbook is a web-based repository of logbook data.

The Hall Beam–Time Accounting Table is the mechanism to summarize and record how the beam time in a shift was spent. The shift leader is responsible for submitting this table at the end of the shift. When submitted, the data are logged in a database and a summary is e-mailed to various people like the run coordinators and the hall leader.

6.6 Authorized Personnel

The authorized personnel is shown in table 6.1.

Name (first,last)	Dept.	Call [5]		e-mail	Comment
		Tel	Pager		
Sergei Boiarinov	Hall-B	5795		boiarino@jlab.org	<i>Contact, first on call</i>

Table 6.1: DAQ: authorized personnel.

server IP	Port	Device

Table 6.2: Port Servers for DAQ

Chapter 7

Trigger Hardware and Software

1

7.1 Overview

Here we give a brief overview of the hall A trigger, including its hardware arrangement, the logic of the trigger, and the usage of the software control. Diagrams of the hardware layout are shown in accompanying figures.

The trigger design is quite flexible and it is relatively easy to add detectors to define new trigger types or to modify existing ones, so long as the detector is fast enough. The trigger supervisor also allows for the possibility of 2nd level triggers which could be used for a later decision.

7.2 Components

The trigger schematics is shown in Fig. 7.1.

Here we describe the software control of the modules involved in the trigger.

Here are the instructions to download the trigger.

The user should look for suspicious error messages in the window from which trigsetup was launched, e.g. to check if connection to the crate is ok.

If individual modules need to be modified for test purposes etc. (e.g. to change thresholds), one may use the expert mode.

7.2.1 Authorized Personnel

The authorized personnel is shown in table 7.1.

¹Authors: S. Boiarinov boiarino@jlab.org

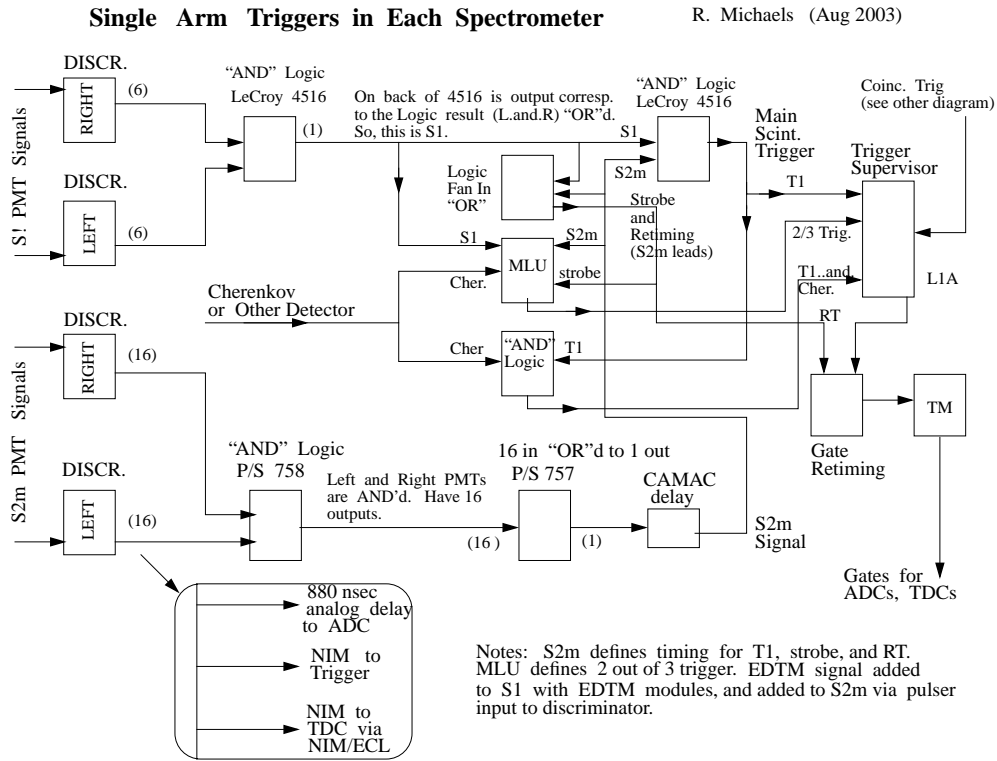

Figure 7.1: Trigger Circuit.

Name (first,last)	Dept.	Call [5]		e-mail	Comment
		Tel	Pager		
Sergei Boiarinov	Hall-B	5795		boiarino@jlab.org	<i>Contact</i>
ValeryKubarovsky	Hall-B	5647		vpk@jlab.org	

Table 7.1: Trigger: authorized personnel.

Chapter 8

Online Analysis, Data Checks

¹

The following tools are available for checking data online.

8.0.2 Scaler Display and Scaler Events

Scaler rates and values are displayed using a ROOT based display.

Normally this is already running, but if it is not running, login as and go to the appropriate directory by typing

8.1 Analysis using CLAS12 Monitoring

CLAS122 offline software package for analyzing Hall B data. This code is documented in a separate chapter but it is worth mentioning here in a list of essential tools for checking data online.

8.1.1 Responsible Personnel

The responsible personnel is shown in table 8.1.

Name (first,last)	Dept.	Call [5]		e-mail	Comment
		Tel	Pager		
Sergei Boiarinov	Hall-B	5795		boiarino@jlab.org	<i>Contact</i>
Veronique Ziegler	Hall-B	6003		ziegler@jlab.org	

Table 8.1: Online analysis: authorized personnel.

¹Authors: S.Boiarinov boiarino@jlab.org

Part V

Offline Analysis Software

Chapter 9

CLAS12 Offline Analysis

¹

The standard offline analysis software for Hall B data is

The XXX code performs tracking in the focal plane and reconstruction to the target. The tracking algorithm has been shown to be accurate for events with one cluster per plane. Noisy events with higher cluster multiplicity and events with more than one good track in the focal plane may not be reconstructed correctly by the present version of the code, but work is in progress to make this type of analysis also reliable.

The scintillator, Cherenkov, and shower counters classes perform basic decoding, calibration (offset/pedestal subtraction, gain multiplication), and summing (for Cherenkovs) or cluster-finding (for showers) of hits. The cluster-finding algorithm of the shower class is basic and currently only capable of finding a single cluster per event. These classes are largely generic and should be able to accommodate most new detectors of the respective type, even with a different geometry and number of channels.

Data of interest can be histogrammed and/or written to a ROOT Tree in the output file. The contents of the output is defined dynamically at the beginning of the analysis. Both 1- and 2-dimensional histograms are supported. Histograms can be filled selectively using logical expressions (cuts).

Table XXX lists the analysis modules available

¹Author: V. Ziegler ziegler@jlab.org

Bibliography

- [1] EPICS Documentation. WWW page. URL <http://www.epics.org/>. see also <http://www.aps.anl.gov/asd/controls/epics/EpicsDocumentation/WWPages/EpicsDoc.html>. 7
- [2] JLab. *EH&S Manual*. URL <http://www.jlab.org/ehs/ehsmanual/>. 7
- [3] JLab. *Personnel Safety System (PSS) manual*. URL http://www.jlab.org/accel/ssg/user_info.html. 7
- [4] *Accelerator Operations Directive*. URL http://opsntsrv.acc.jlab.org/ops_docs/online_document_files/ACC_online_files/accel_ops_directives.pdf. URL is available inside JLab site. 7
- [5] Jefferson Lab, (12000 Jefferson avenue, Newport News, VA 23606). URL <http://www.jlab.org>. Telephone numbers: (757)-269-XXXX, Pager numbers: (757)-584-XXXX. 8, 13, 15, 19, 24, 26, 27
- [6] CODA documentation. WWW page. URL <http://coda.jlab.org/>. 21