



PRad Design and Engineering

Bob Miller

November 12, 2015

Outline

- Component Layout
- Vacuum Chamber Design
- Thin Window Design
- Safety Requirements for Thin Window
- Window to Beam Pipe Connection
- Component Status

Description

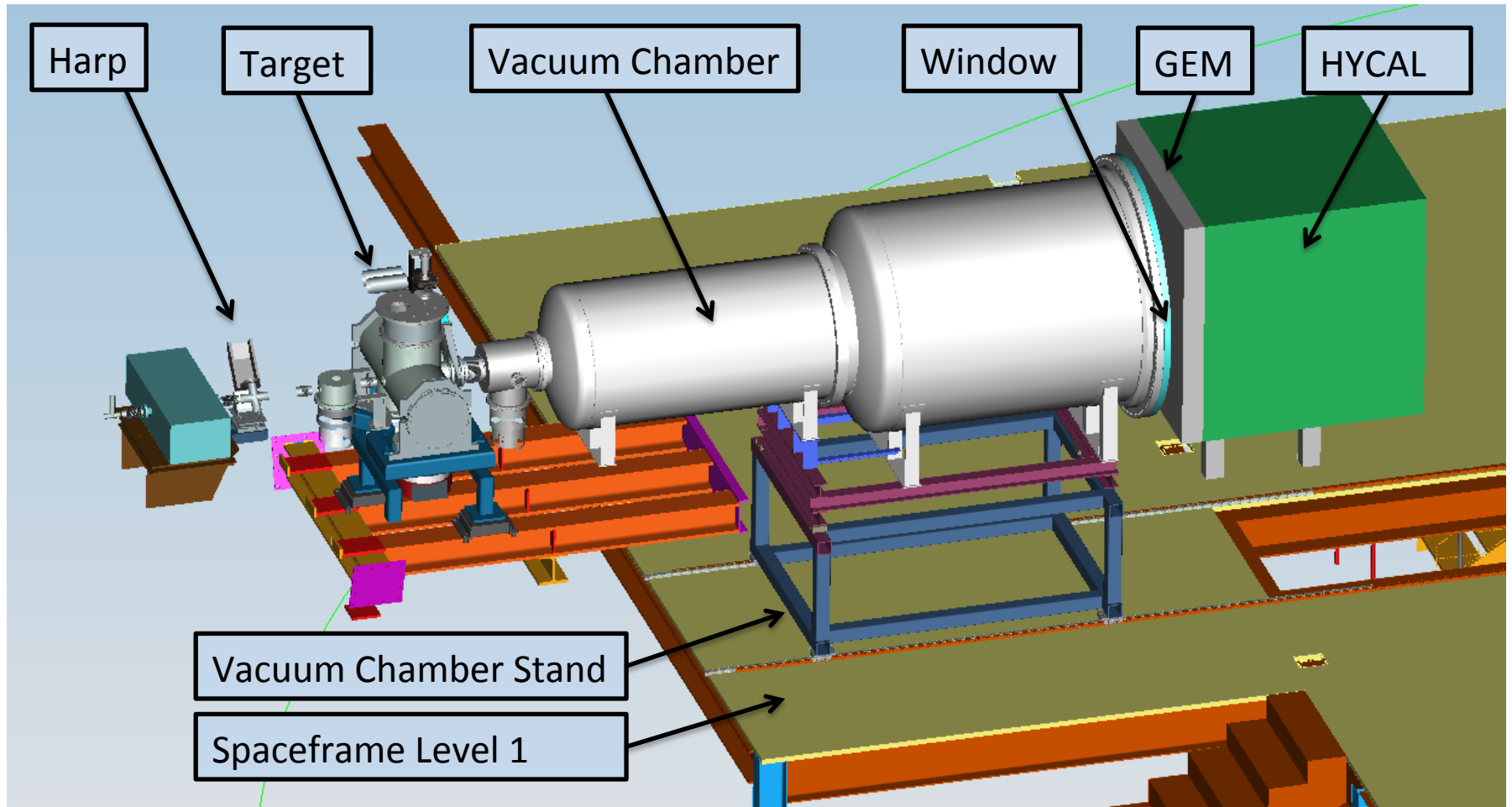

Vacuum Chambers

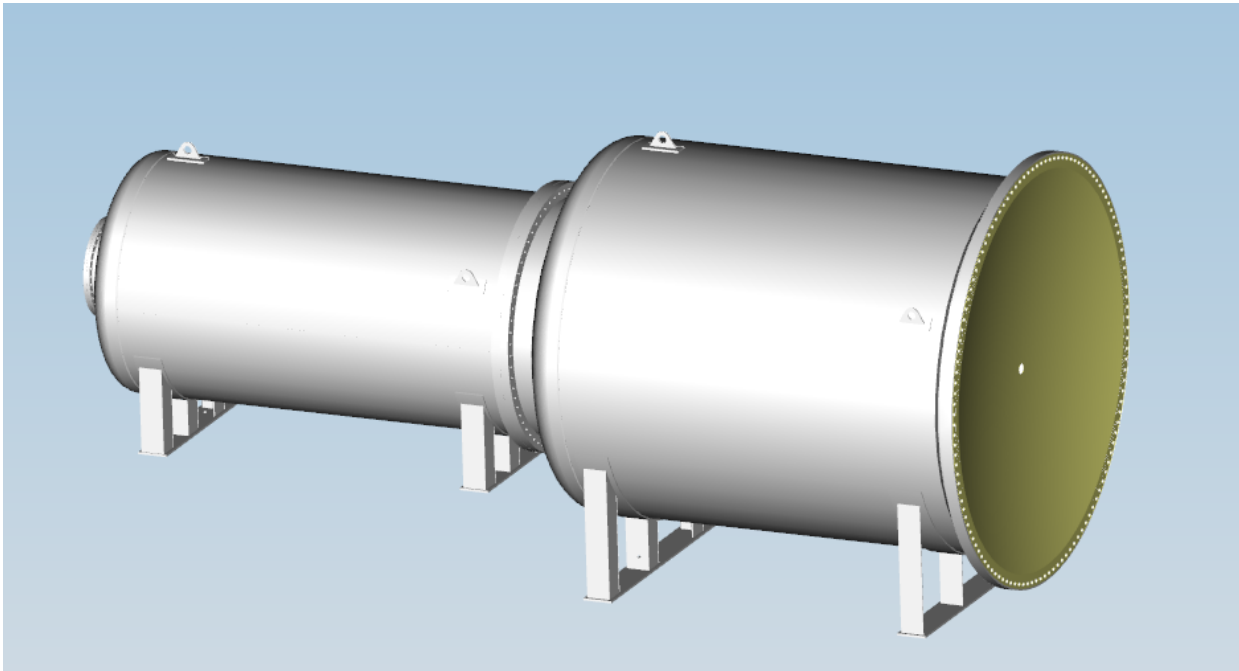

- The vacuum chamber consists of 2 chambers bolted together with a thin window on the downstream end
- Large chamber 62" diameter, small chamber 39" diameter
- Chambers have a combined volume of 200 cubic feet

Vacuum Chamber Design and Testing

- The vacuum chambers were designed and built by Meyer tool – calculations were reviewed by George Biallas.
- The chambers were pressure tested to 15 psi at Meyer Tool with a plate on the window end
- The chambers were tested under full vacuum at Meyer Tool with an actual PRad window without the center hole for the beam pipe adapter

Thin Window Design

- The PRad window has a 66" diameter, made from 0.063" thick, 2024-T3 aluminum.
- Window is the same size as Hall C Heavy Gas Cherenkov (HGC) window. The HGC window is 0.043" thick and was tested to 60 psi without failure.
- Most thin windows in use at JLab are between 0.005" and 0.020" thick.
- Window operating condition is full vacuum (14.7 psi)

Thin Window Forming

- The PRad window was formed using guidance from Dave Kashy and the ES&H manual, 6151 Appendix T3, Safety Requirements for Thin Window Design.
- The ES&H manual recommends that the formed window stress is the lesser of 50% of ultimate stress or 90% of yield stress, and only 30% of the available elongation of the material is used.
- Window was hydrostatically formed at 35 psi
- The PRad window is formed to a window bow of 2.2 inches, resulting in 52% of the ultimate stress, 78% of the yield stress, and 3% of the available elongation.

Safety Requirements for Thin Window

- A shield will be installed over the window to protect against foreign object damage
- The shield will be installed whenever the chamber is not under vacuum.
- While under vacuum, near the window
 - Hearing protection will be required
 - Eye protection will be required
 - Signs and barriers will be in place to warn staff of the presence of a thin window

Window to Beam Pipe Adapter

- The window will be attached to a beam pipe using a Jab fitting
- The fitting was used successfully on a Hall B window that was 28" diameter, 0.0085" thick (66580-C-02743)
- Hall C uses a similar design on their 0.020 thick target chamber window (67153-56029)
- Will hydrostatically test the fitting on the window to 30 psi

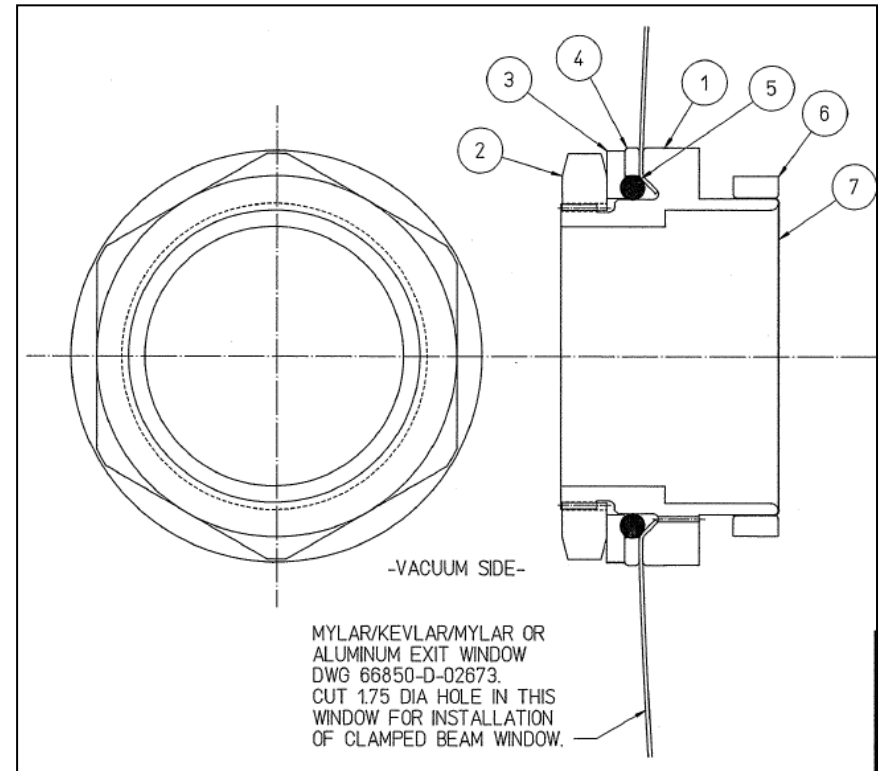

Window to Beam Pipe Connection

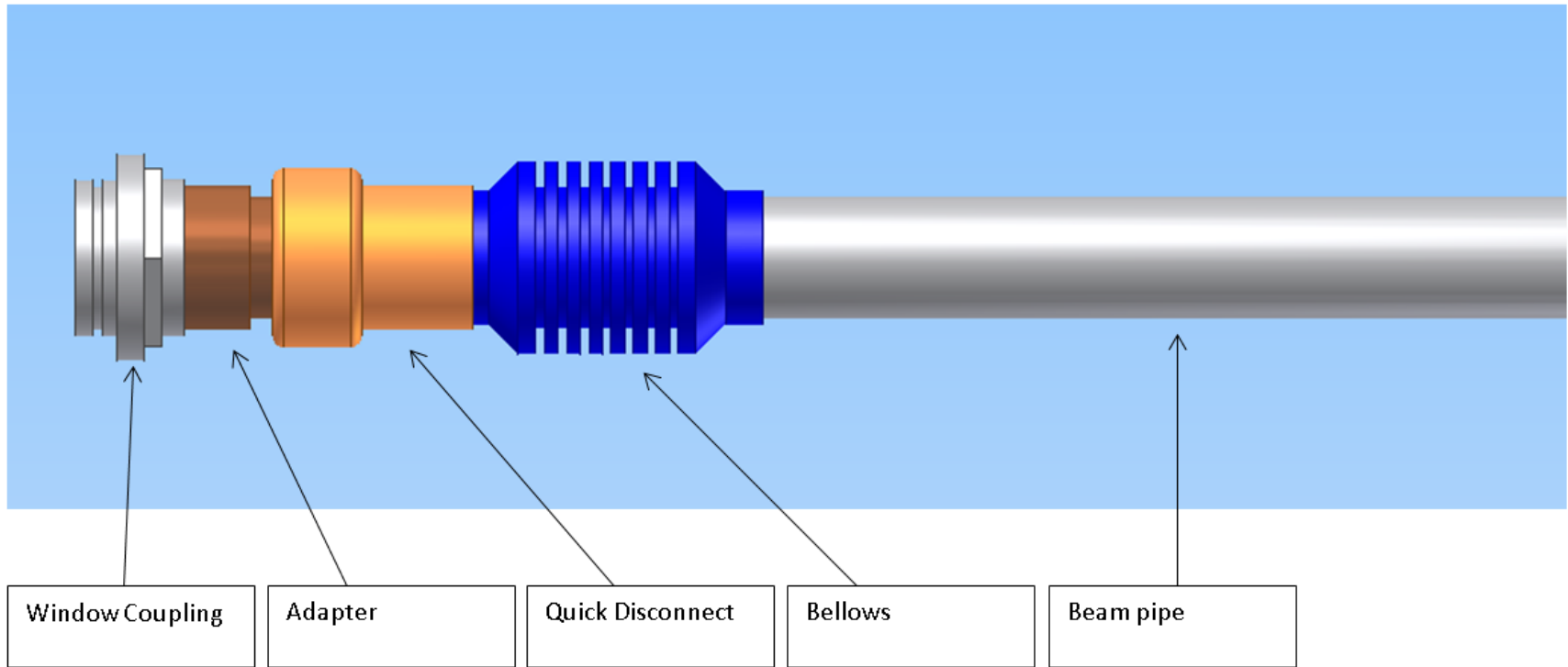

Component Status

Component	Design	Date Received
Target	Complete	2014
Target Stand	Complete	2014
Vacuum Chamber	Complete	2015
Window	Cut and Formed	2014
Window	Center Hole Machined	Dec 2015
Window	Hydrostatic test with beam pipe adapter	Jan 2016
Window Shield	Design Complete by Nov 30	Jan 2016
Vacuum Chamber Stand	Design Complete	Jan 2016
Beam Pipe Components (adapter, bellows, flanges)	Design Complete by Nov 30	Dec 2016
Gem Detector Mounts	Designed at Duke University	Jan 2016