

Trigger Considerations

- Switching between single arm and coincidence mode fast, easy and as little hardware changes as possible
- Implementation of triggers in NIM logic
- No “cheating” in coincidence mode as during Argon run
- No Retiming of signals (no RT module)
- RHRS TS is controlling DAQ in coincidence mode

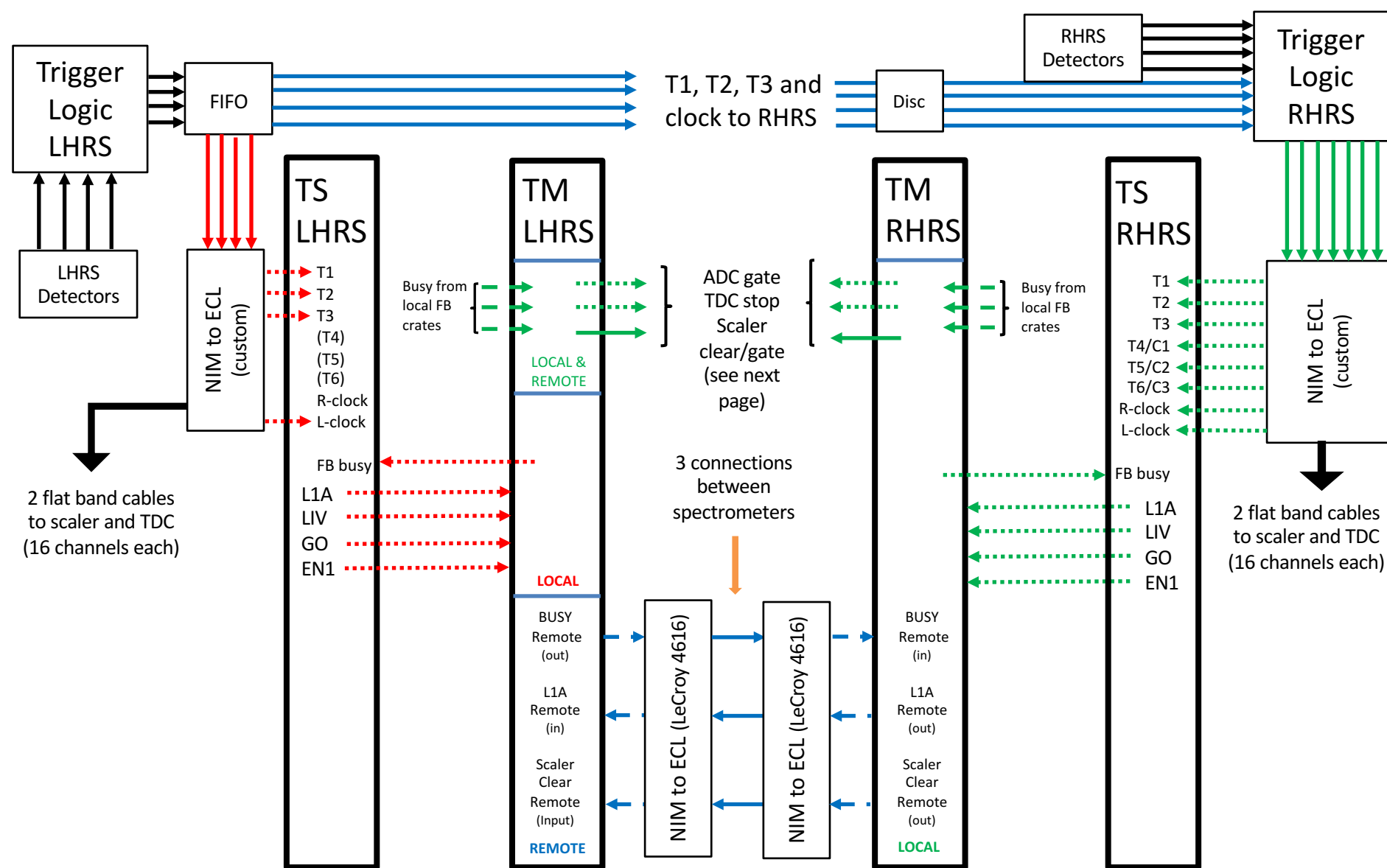

Flow of ADC gate, TDC stop and scaler signals for both arms

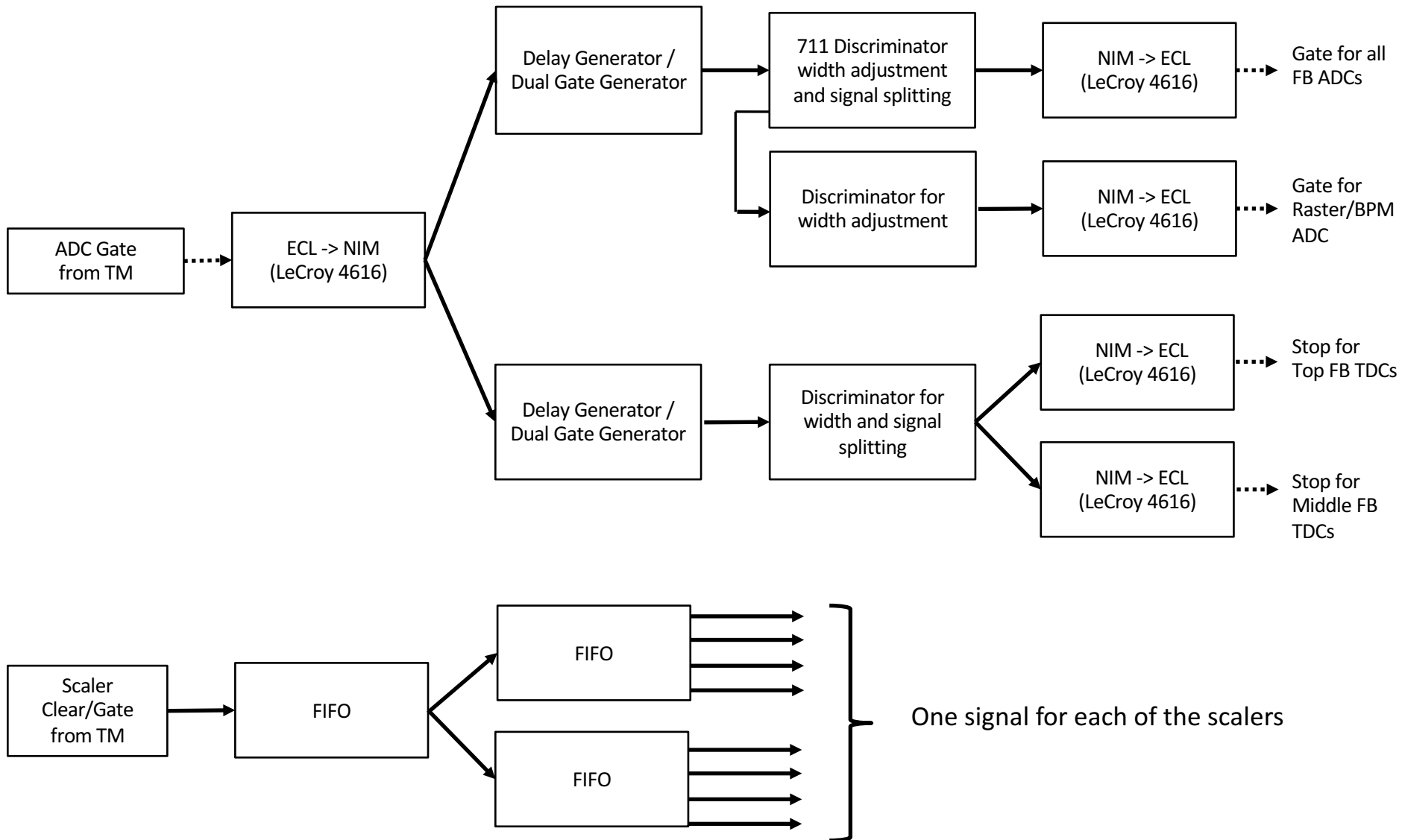

Trigger Logic for 2 DAQ mode (single arm configuration)

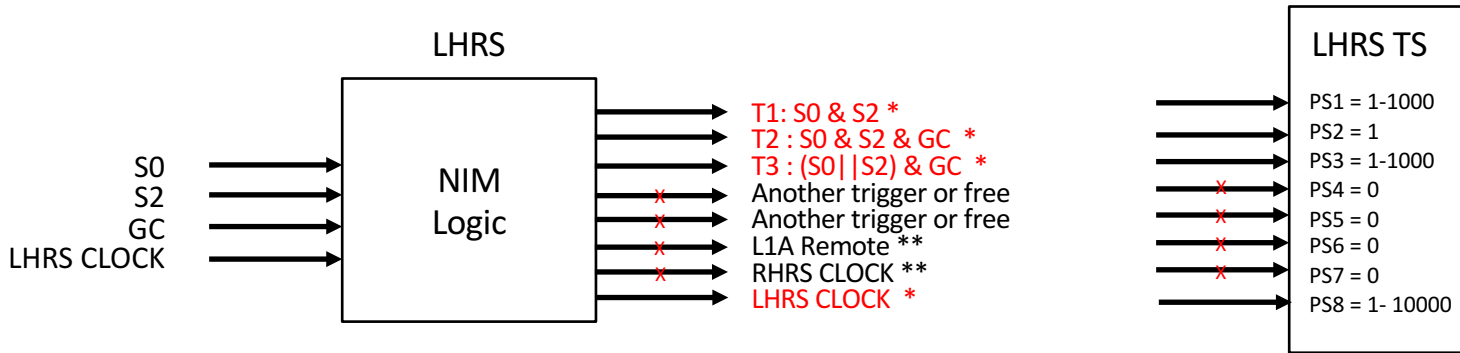

X : in/output not used in trigger design

* Connections to RHRs are intact but triggers are disabled on RHRs by TS prescales

** Connections from coincidence mode

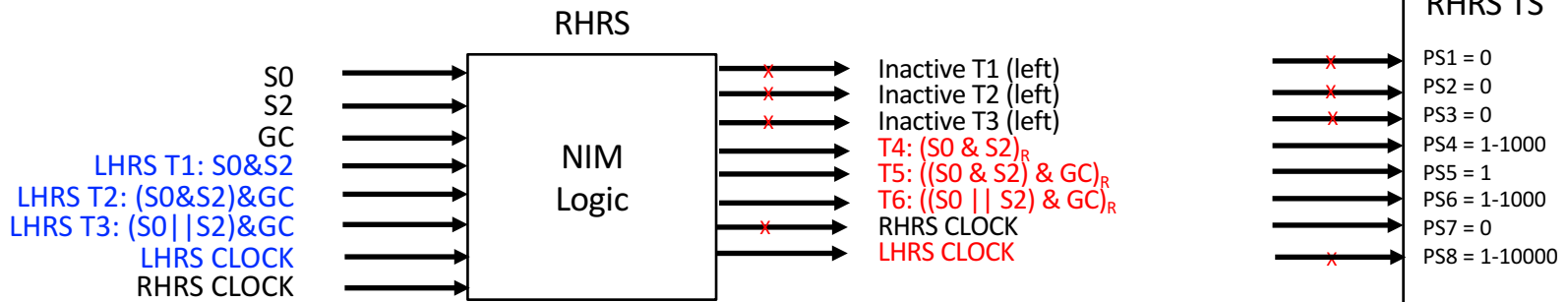

- T1 – T3 LHRs single triggers - similar for all experiments
- T4 – T6 RHRs single triggers

Single Arm Triggers (S0&S2); (S0&S2)&GC; (S0||S2)&GC

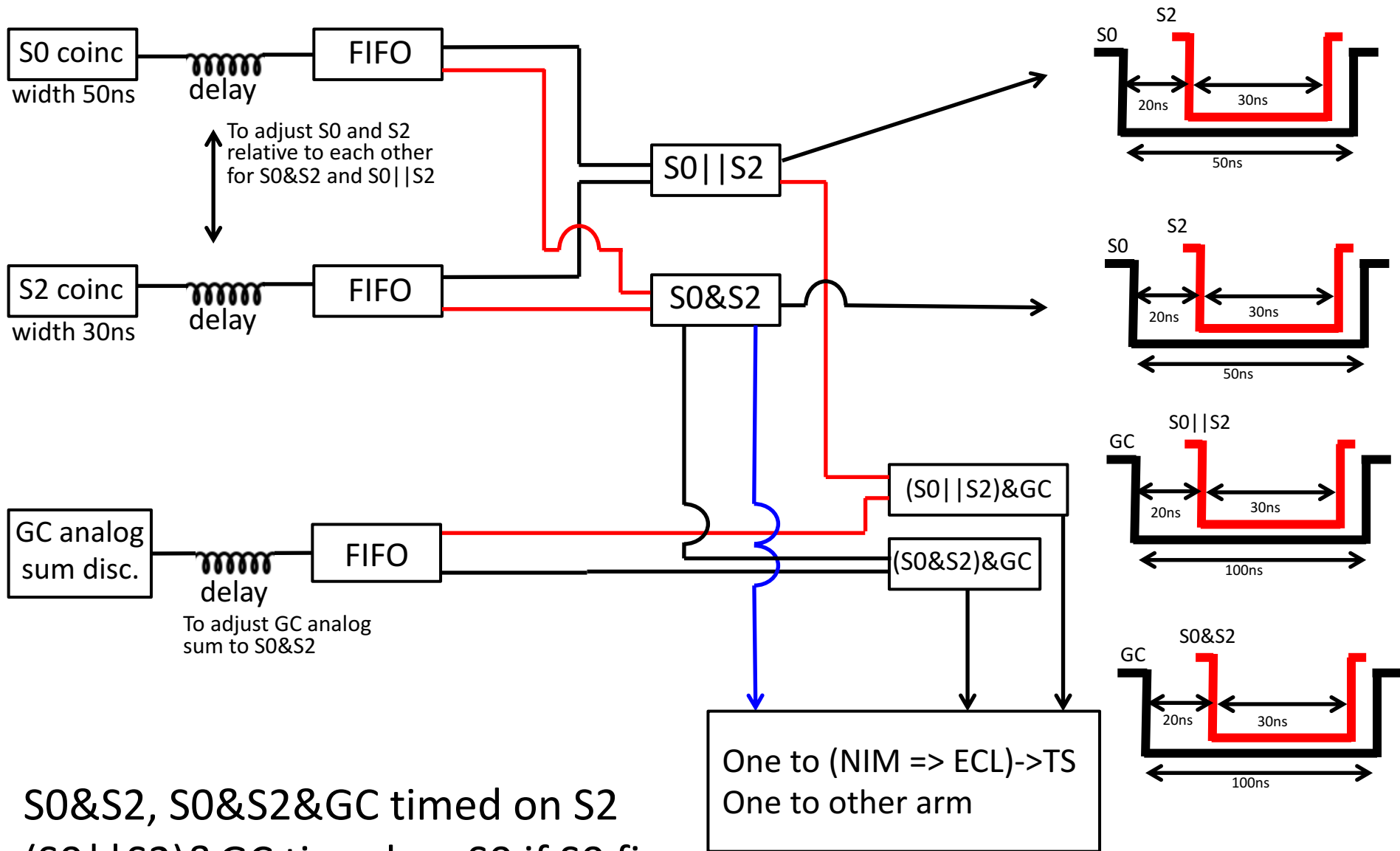

S0&S2, S0&S2&GC timed on S2
 (S0||S2)&GC timed on S0 if S0 fires

Schematics during December 2017 run

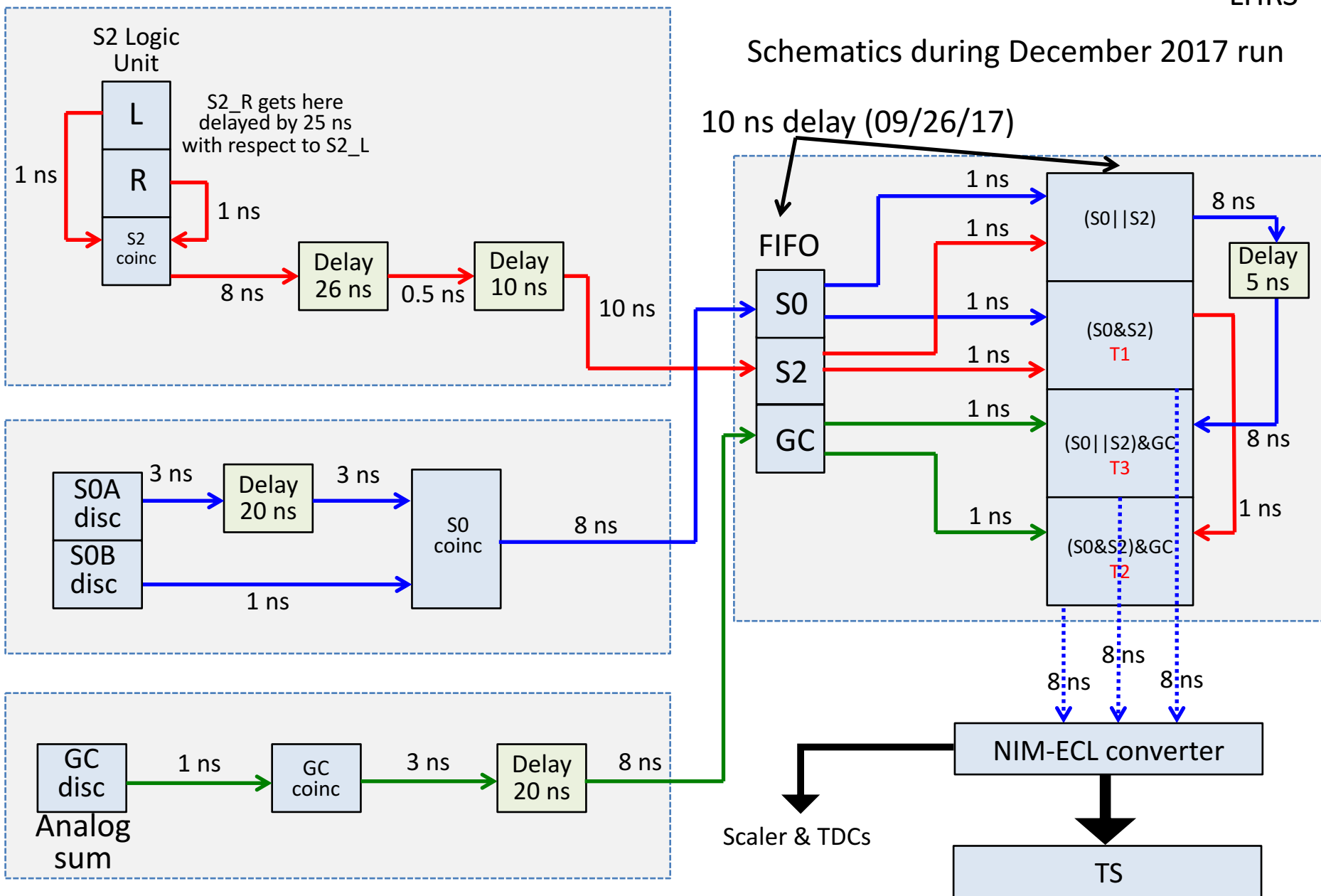

Schematics during Marathon Spring 2018

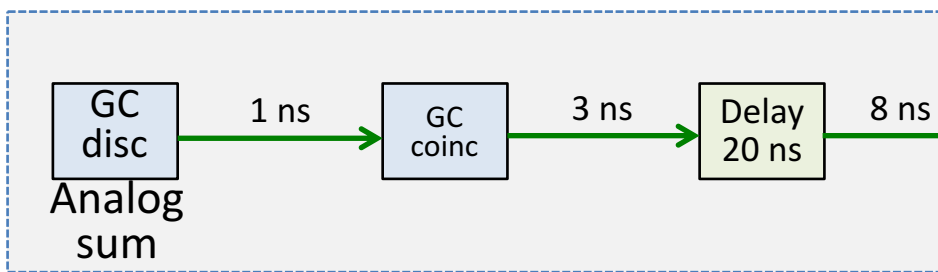
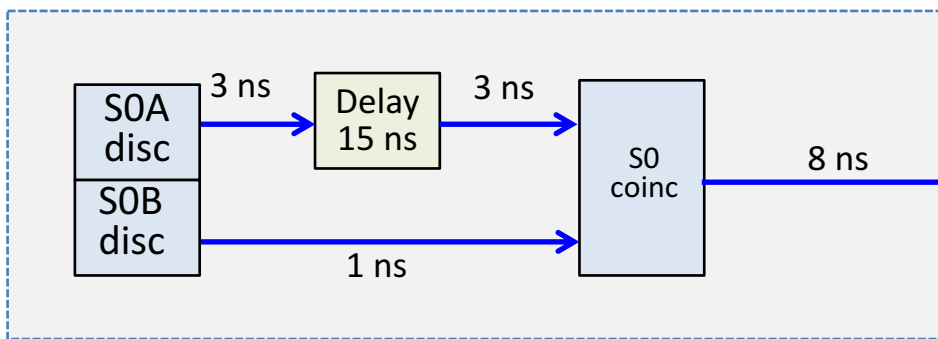
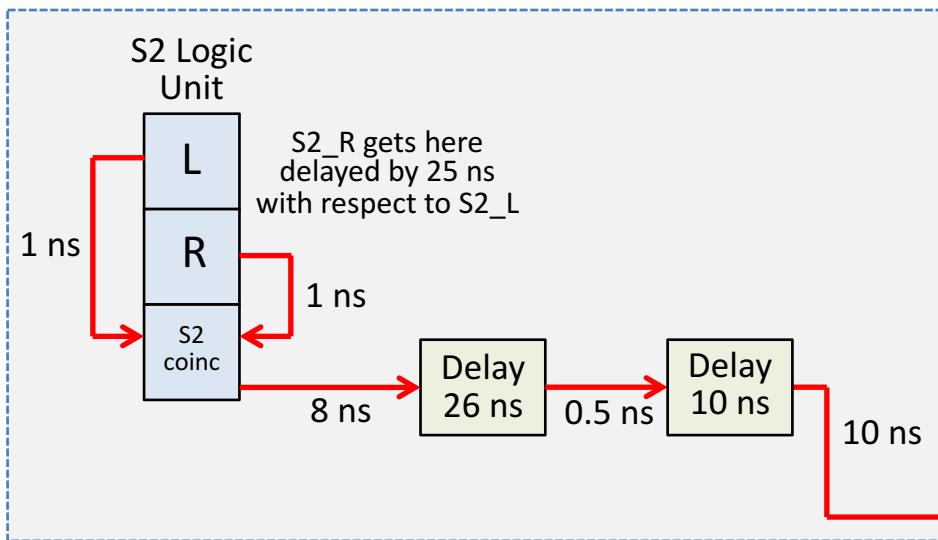

run
10 ns delay (09/26/17)

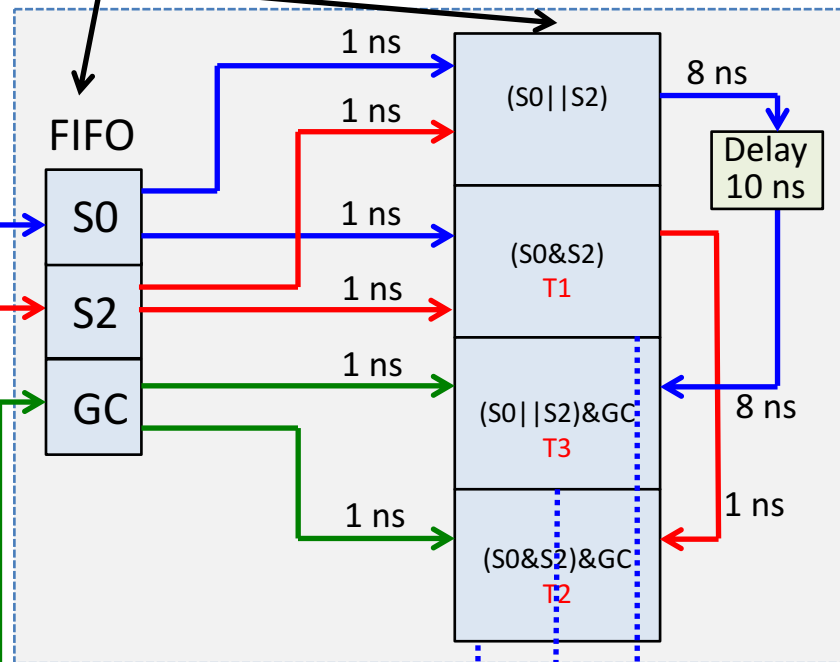

Scaler & TDCs

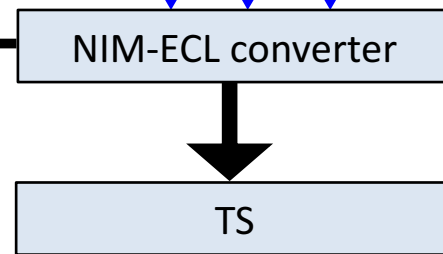

Schematics during December 2017 run

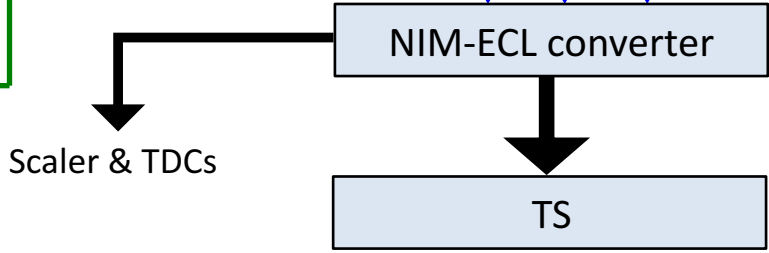
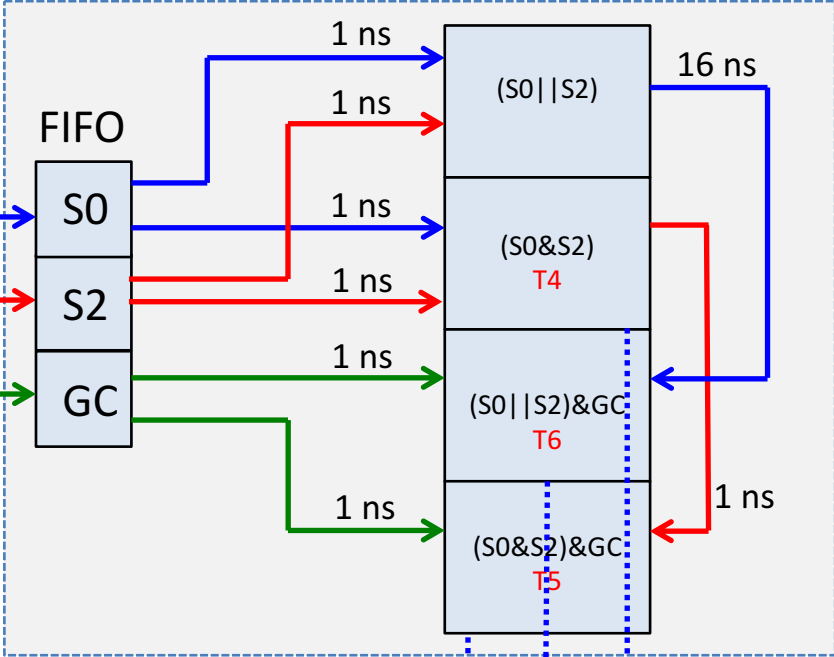
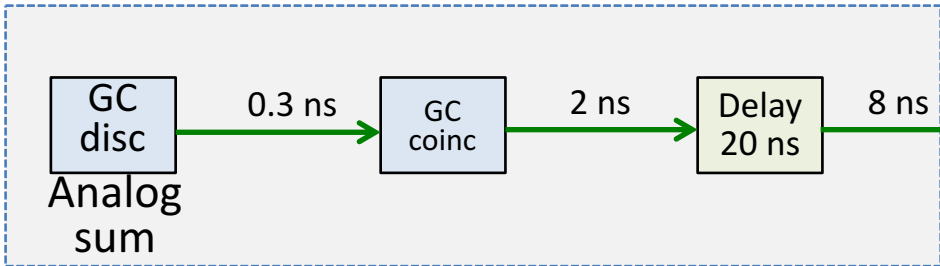
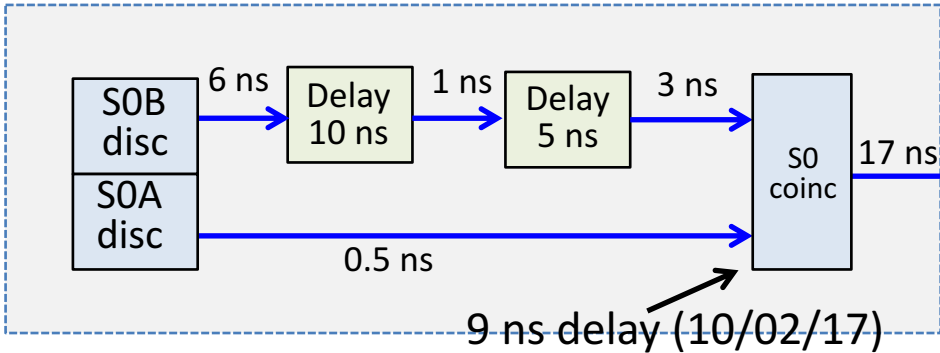
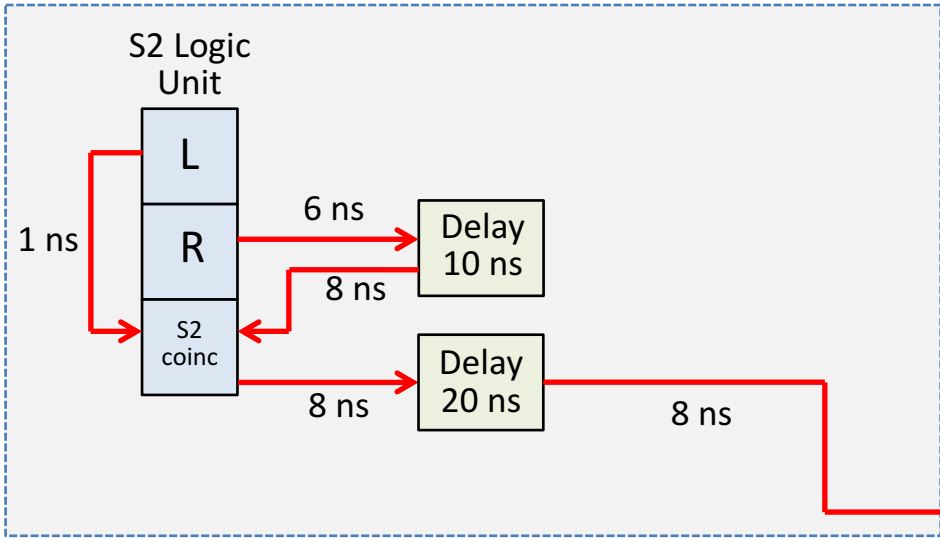

Schematics during Marathon (Spring 18) run

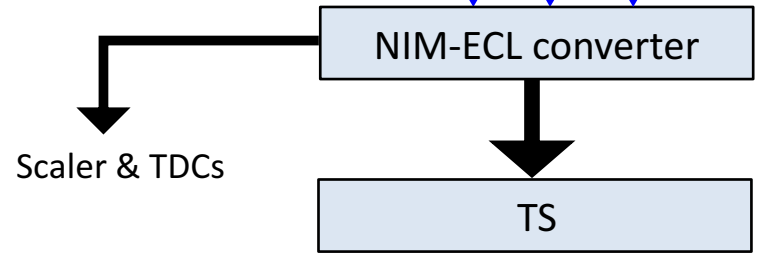
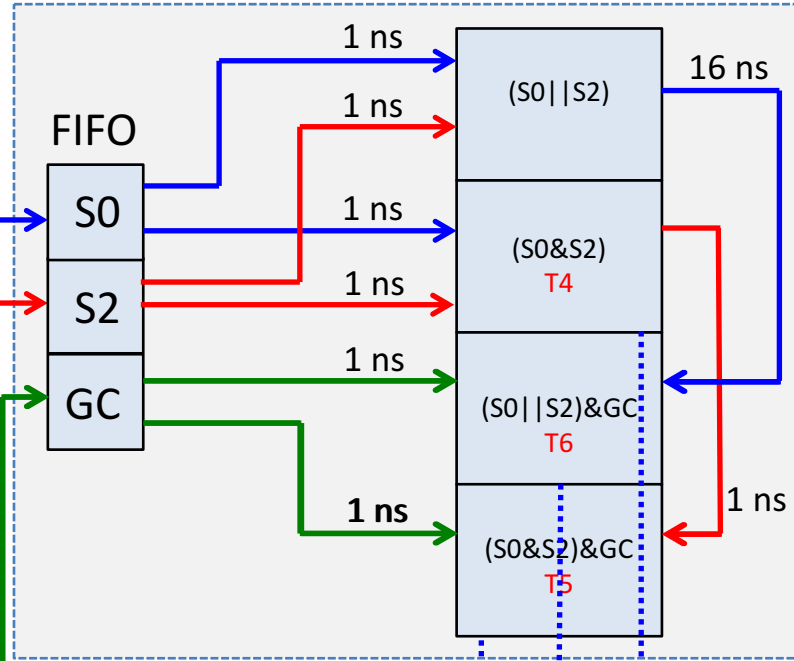
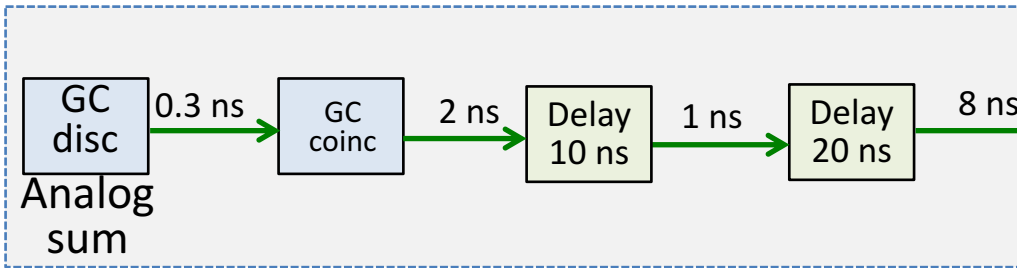
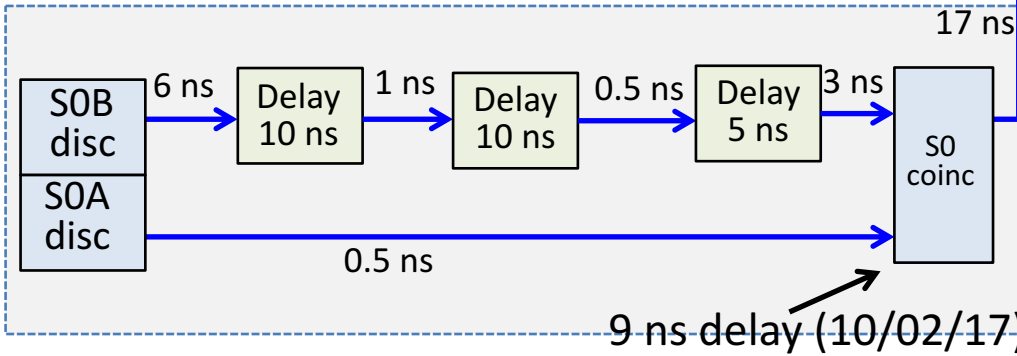
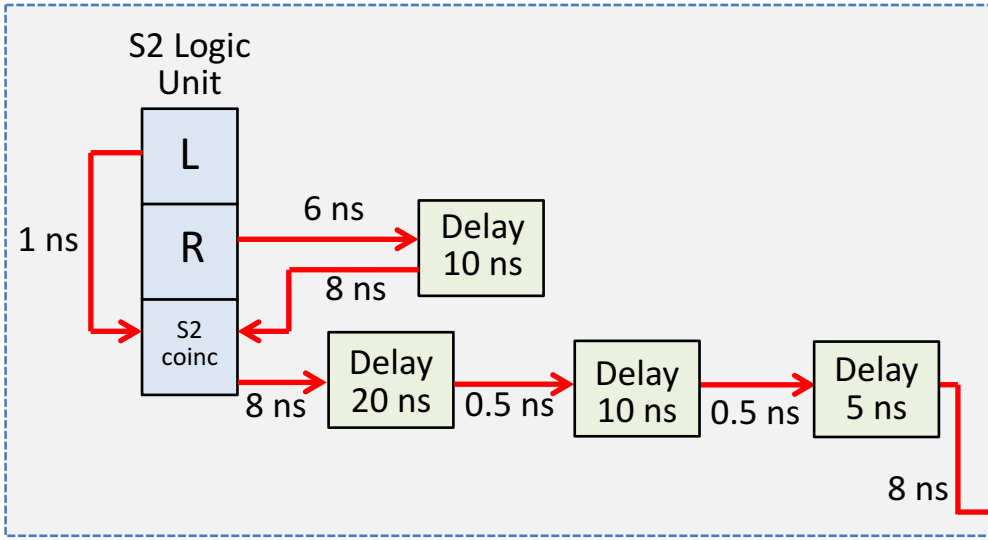

Trigger Logic for 1 DAQ mode (coincidence configuration)

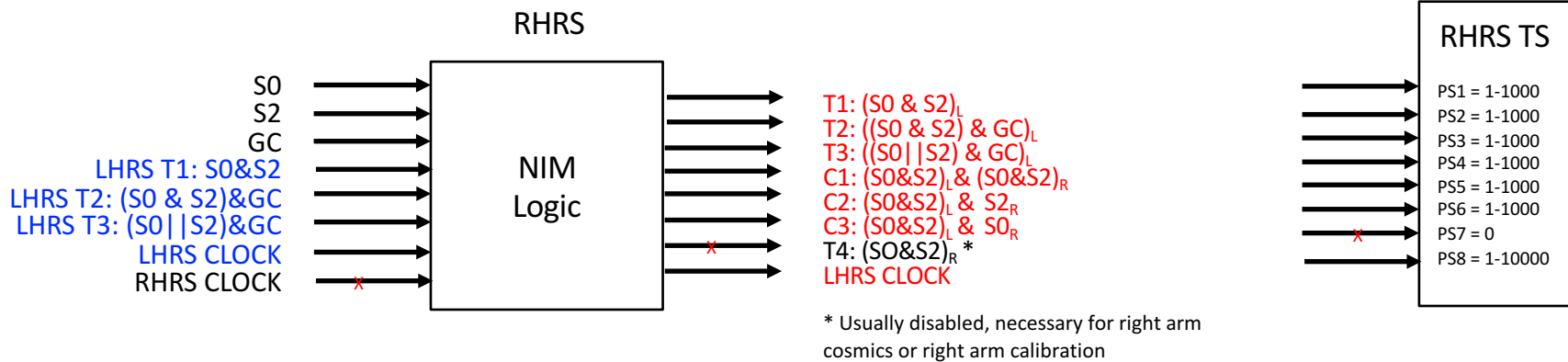
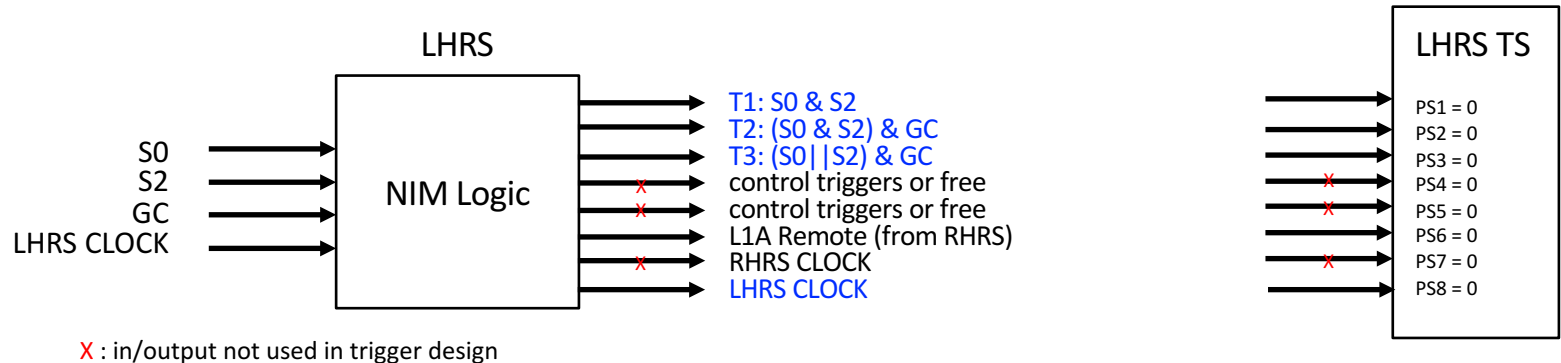

- Some of the signals on the RHRS have to be delayed to be in time with LHRs triggers
- T1 – T3 LHRs single triggers
- C1 – C3 Coincidence triggers

Coincidence triggers

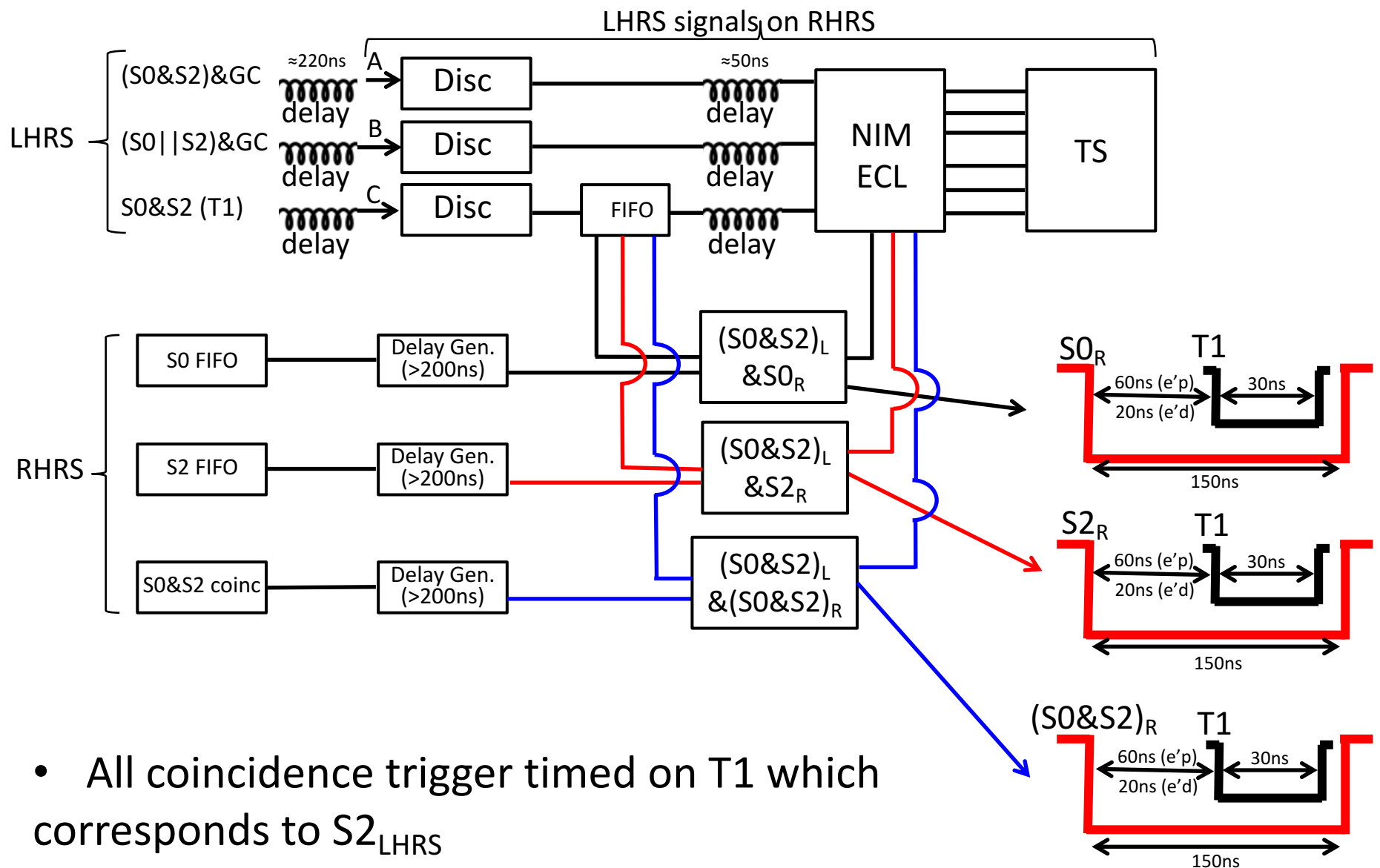

- All coincidence trigger timed on T1 which corresponds to $S2_{LHRs}$
- > all trigger but $(S0 || S2)\&GC_{LHRs}$ timed on $S2_{LHRs}$
- $(S0 || S2)\&GC_{LHRs}$ timed on $S0_{LHRs}$ if S0 fires

Signals Exchange LHRS and RHRS

Fast cables (black, 222ns):

1. T1
2. T2
3. T3
4. L1A Remote
5. LHRS clock
6. Retiming signal , $(S0 || S2)_{RHRS}$

Slower cables (grey, 240ns):

1. RHRS clock
2. Busy Remote
3. Scaler Gate/Clear Remote

Flatband RS485 connection TS to LHRS Fastbus and VME crates

Next slides are not up to date!!!
15 January 2018

have to be modified for correct
setup

Trigger Logic for 1 DAQ mode

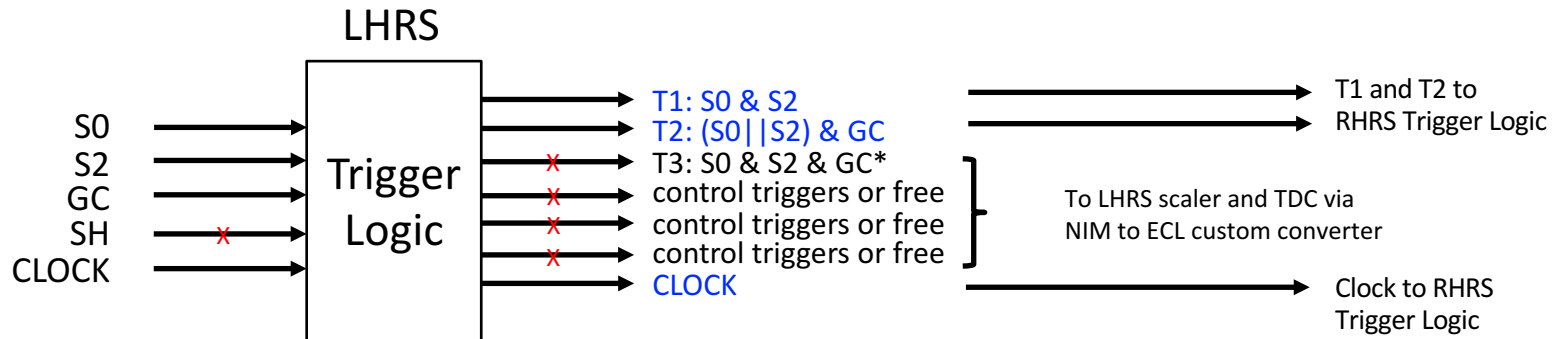

X : in/output not used in trigger design

*T3 is regenerated from T1 and T2 on RHRS to save one connection cable

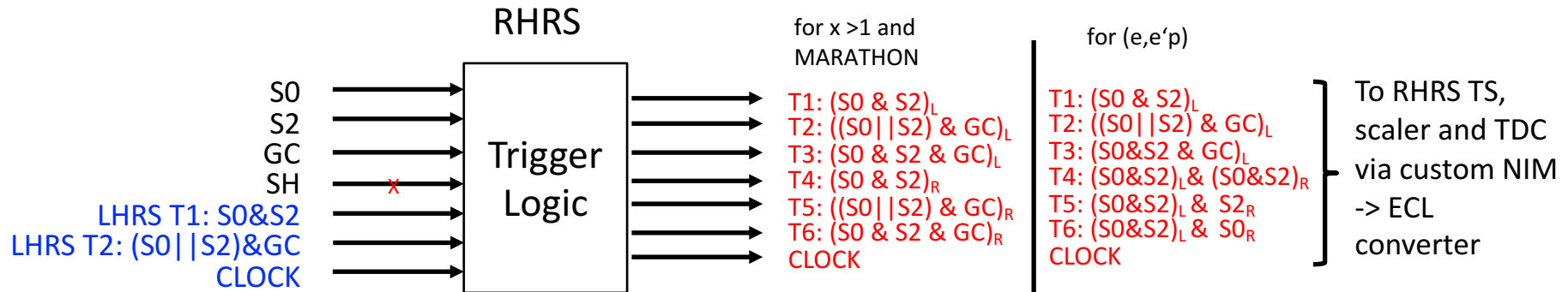

- Trigger logic can be either NIM or MLU or both with one output as control in scaler and TDC
- Some of the signals on the RHRS have to be delayed to be in time with LHRs triggers
- T1 – T3 LHRs triggers - similar for all experiments
- T4 – T6 RHRS triggers (single or coincidence triggers)

Trigger Logic for 2 DAQ mode

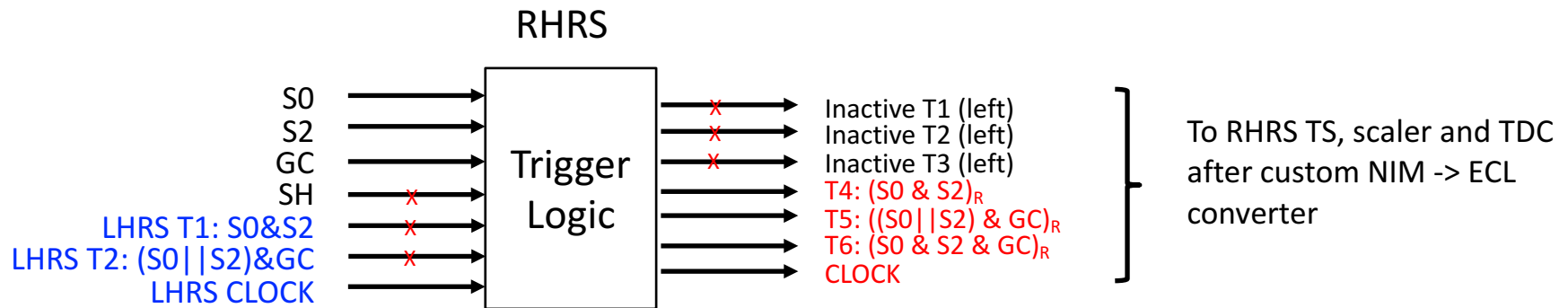
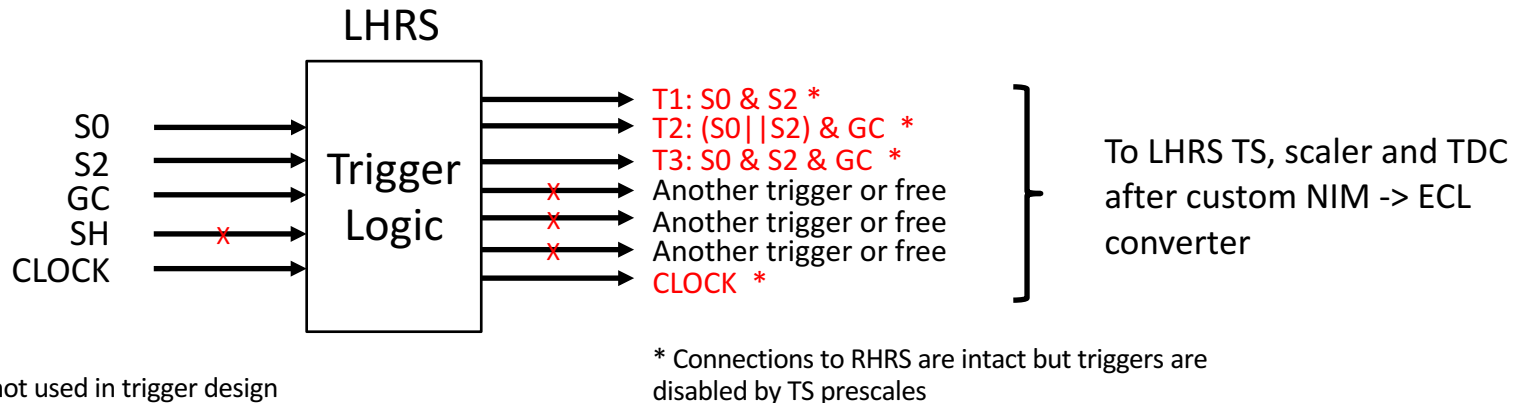

- Trigger logic can be either NIM or MLU or both with one output as control in scaler and TDC
- T1 – T3 LHRS single triggers
- T4 – T6 RHRS single triggers
- Single triggers are fed to the individual TS of the corresponding sides
- Using more triggers on the RHRS involves changing cables

Trigger Logic for 1 DAQ mode (not up to date)

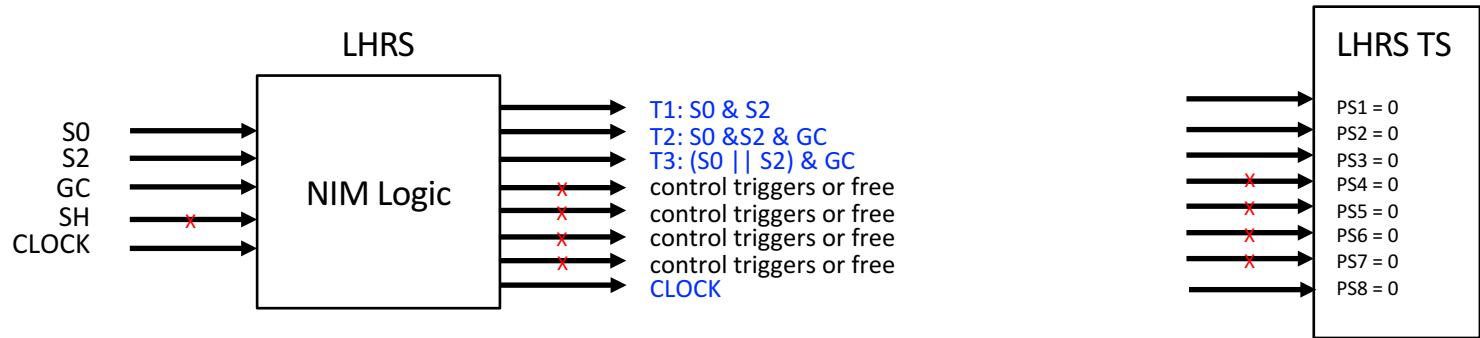

X : in/output not used in trigger design

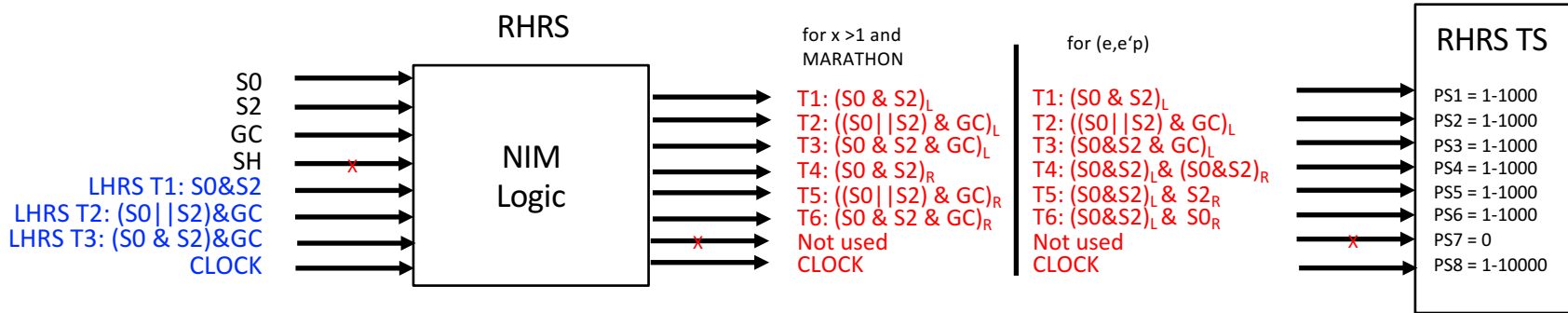

- Some of the signals on the RHRS have to be delayed to be in time with LHRs triggers
- T1 – T3 LHRs triggers - similar for all experiments
- T4 – T6 RHRS triggers (single or coincidence triggers)

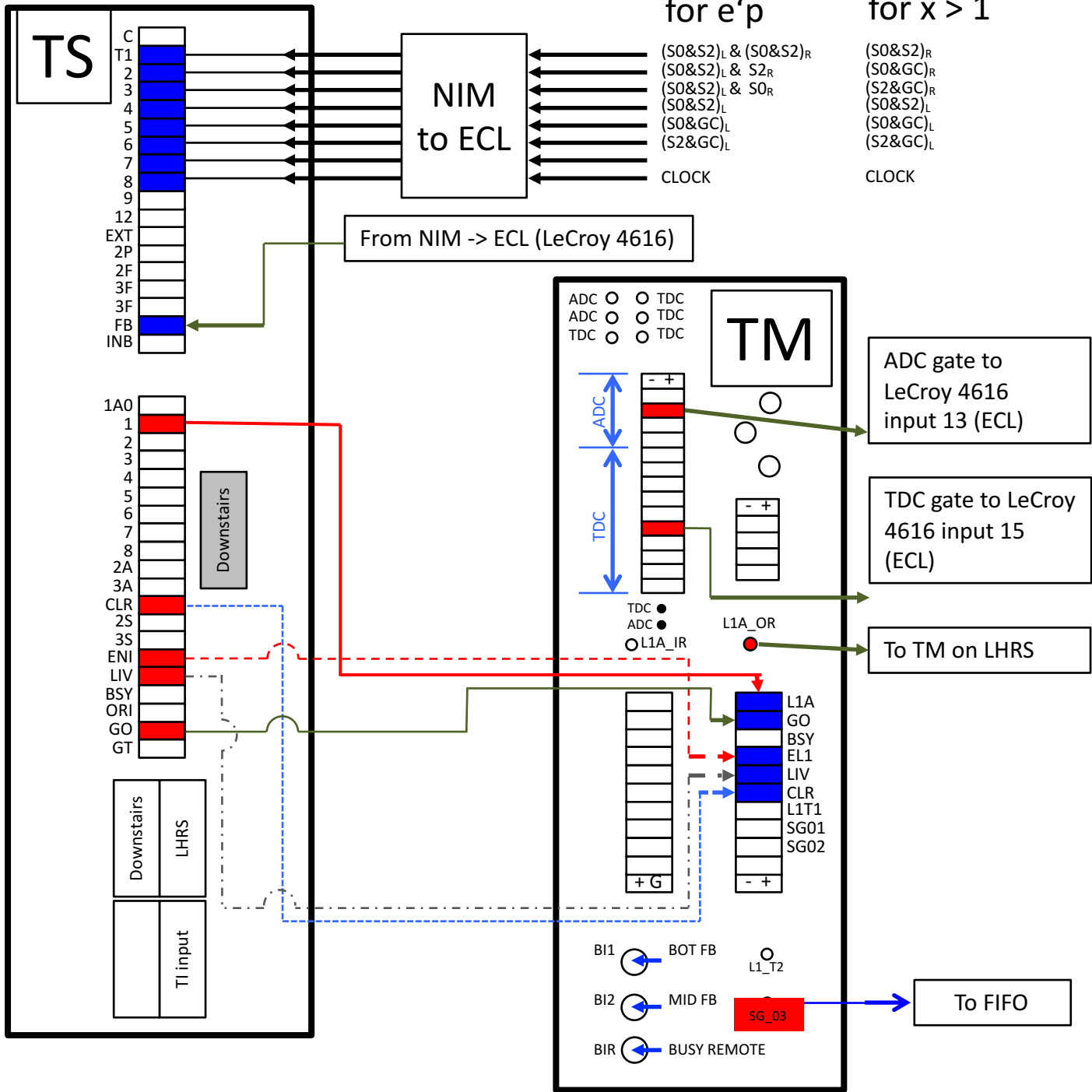

RHRS
TS, TM

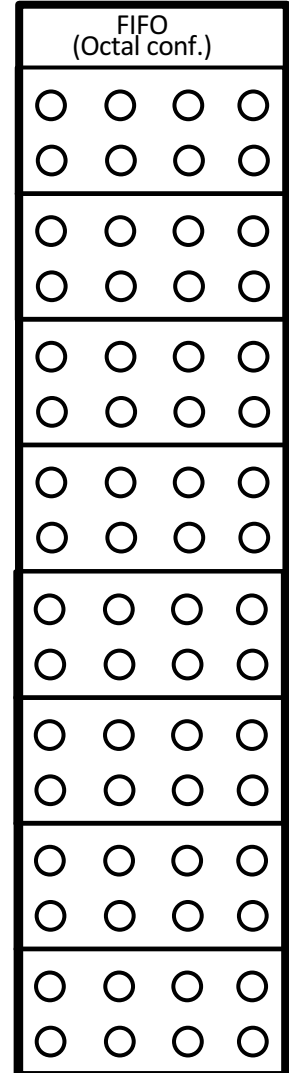
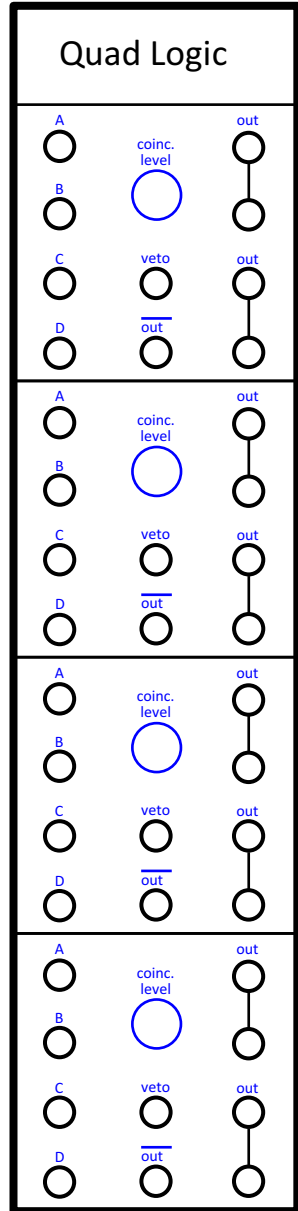
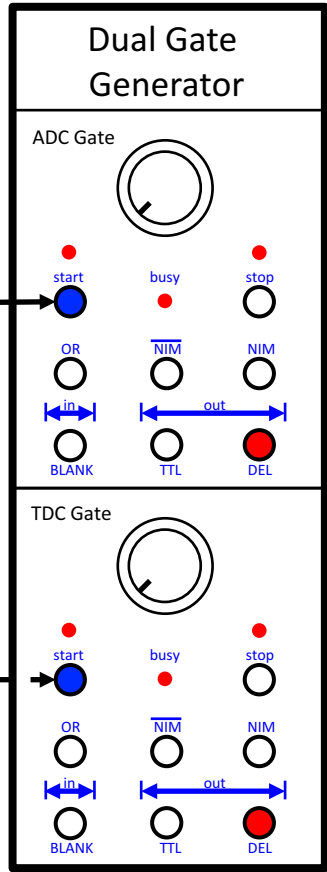
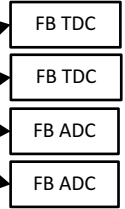
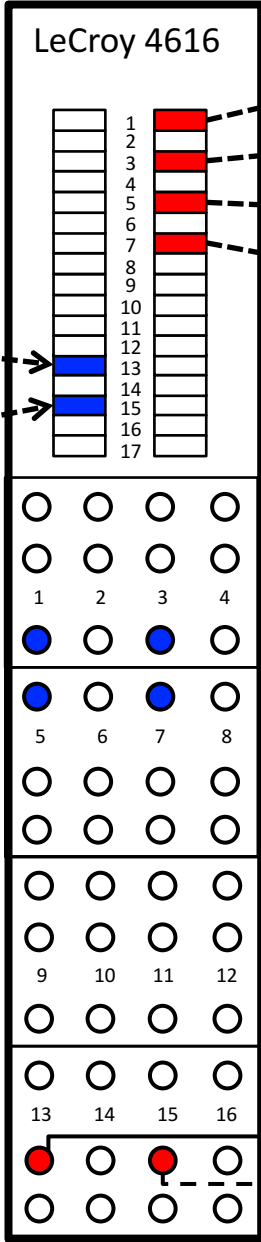

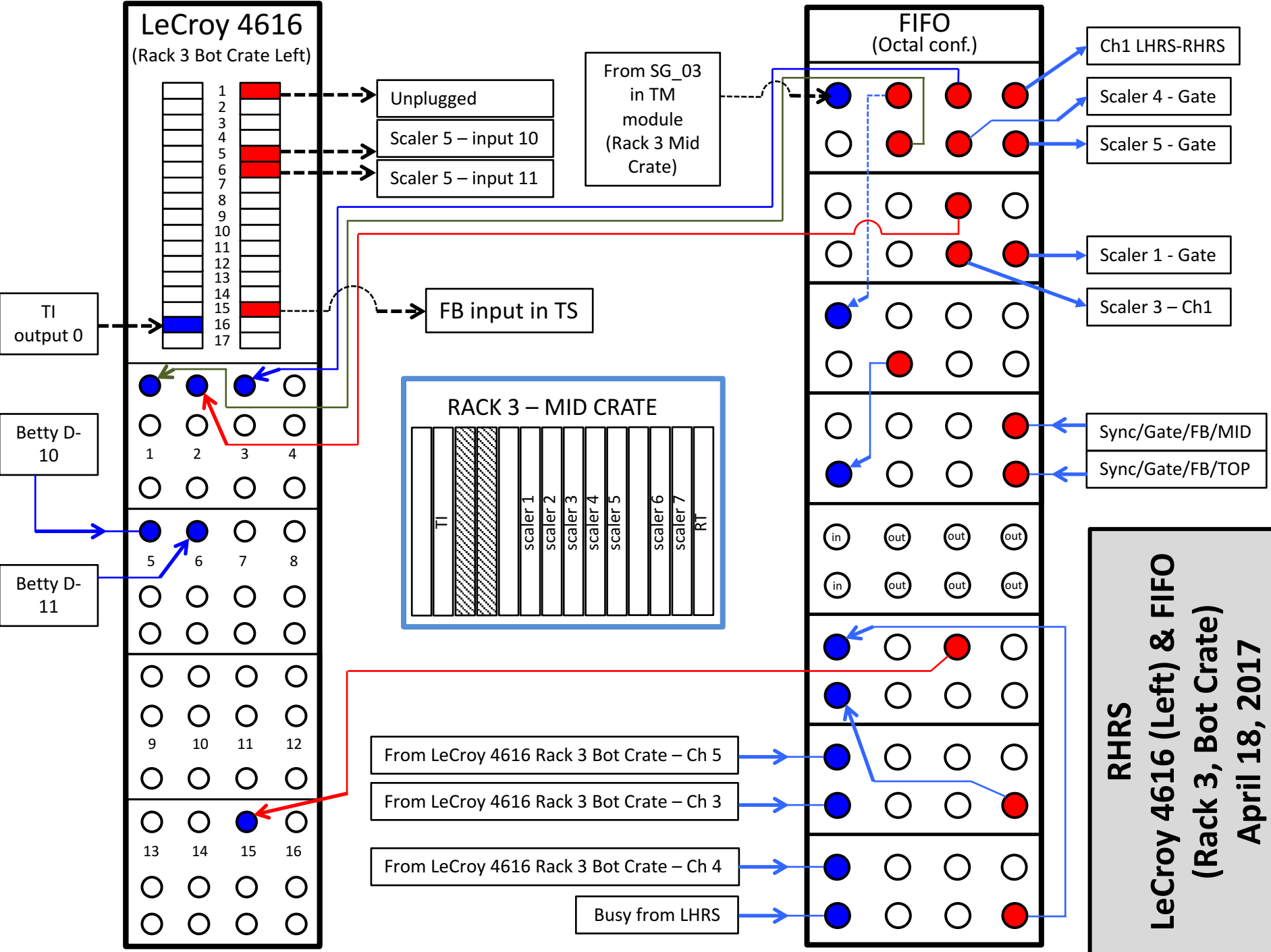

LeCroy 4616 (Rack 3 Bot Crate Right)

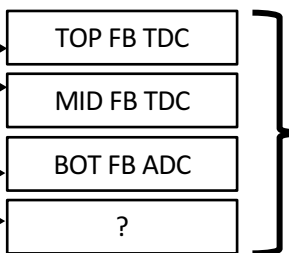
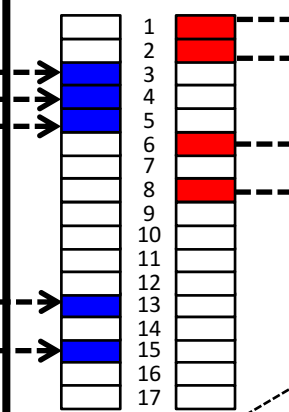

Going Downstairs

RHRS
LeCroy 4616 (Right) & NIM-ECL
(Rack 3, Bot Crate)
April 18, 2017

Downstairs ?
 LeCroy 4616 ?

From TS (output 3)
 From TM (TDC Gate)

FIFO Rack 3 Bot Crate Module 7
 FIFO Rack 3 Bot Crate Module 8

Logic Unit
 Logic Unit

Dual Gate Generator

Dual Gate Generator

FIFO Rack 3 Bot Crate Module 7

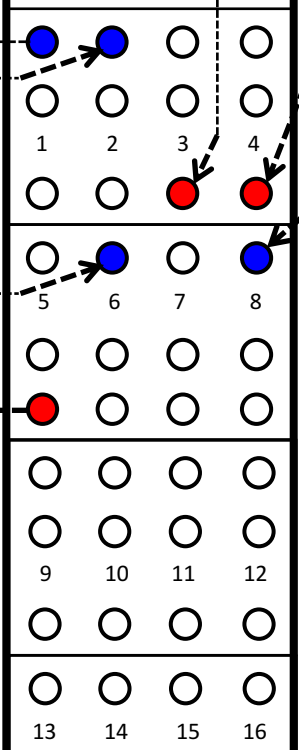

Logic Unit (just making copies)

From LeCroy 4616 Rack 3 Top Crate (BCM 3) [EMPTY]

Discriminator

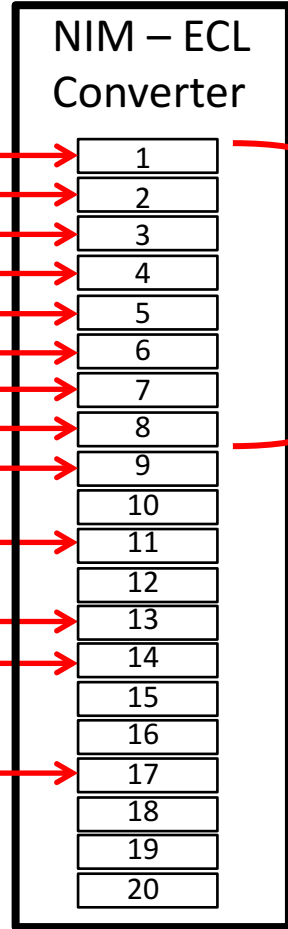

- S0 & S2 → 1
- S0 & GC → 2
- S2 & GC → 3
- S0 & SH → 4
- S2 & SH → 5
- GC & SH → 6
- EDTM → 7
- CLOCK → 8
- From LeCroy 4616 Rack 3 Top Crate (BCM 3) [EMPTY] → 9
- 10
- 11
- 12
- 13
- 14
- 15
- 16
- RT → 17
- [EMPTY] → 18
- [EMPTY] → 19
- [EMPTY] → 20

To TS

[TERMINATED]
 [TERMINATED]
 [TERMINATED]
 [EMPTY]
 [EMPTY]
 [EMPTY]

