

Coincidence Trigger and Retiming

Florian Hauenstein

14th March 2017

Overview

- LHRS Trigger Setup
- RHRS Trigger Setup
- Coincidence Trigger
- L1A Accept and Retiming
- ADC gate
- (Modifications from first setup)
- (What has to be changed for fall)

Introduction

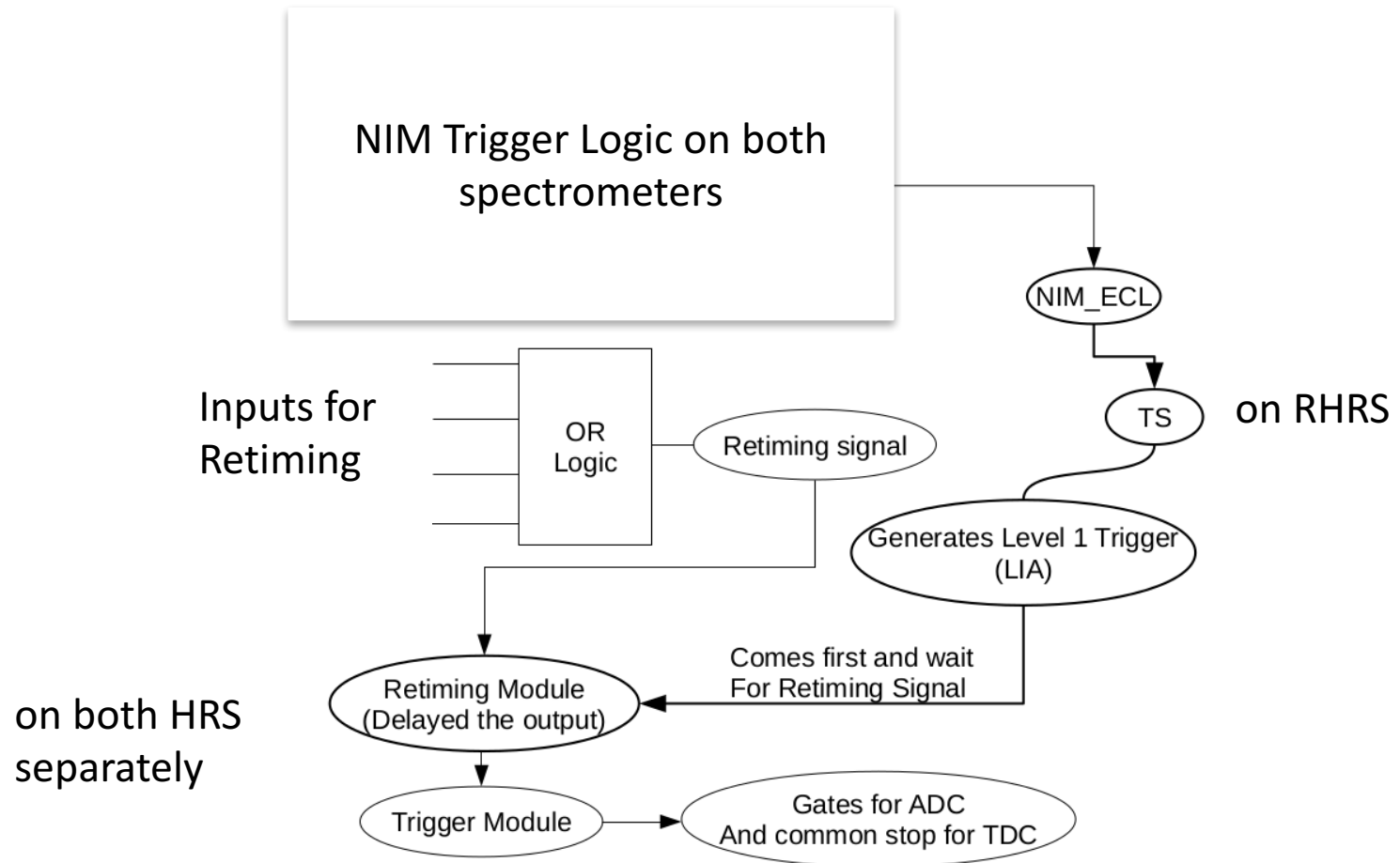

Schematics of Trigger Setup LHRS (valid till 03/07/17)

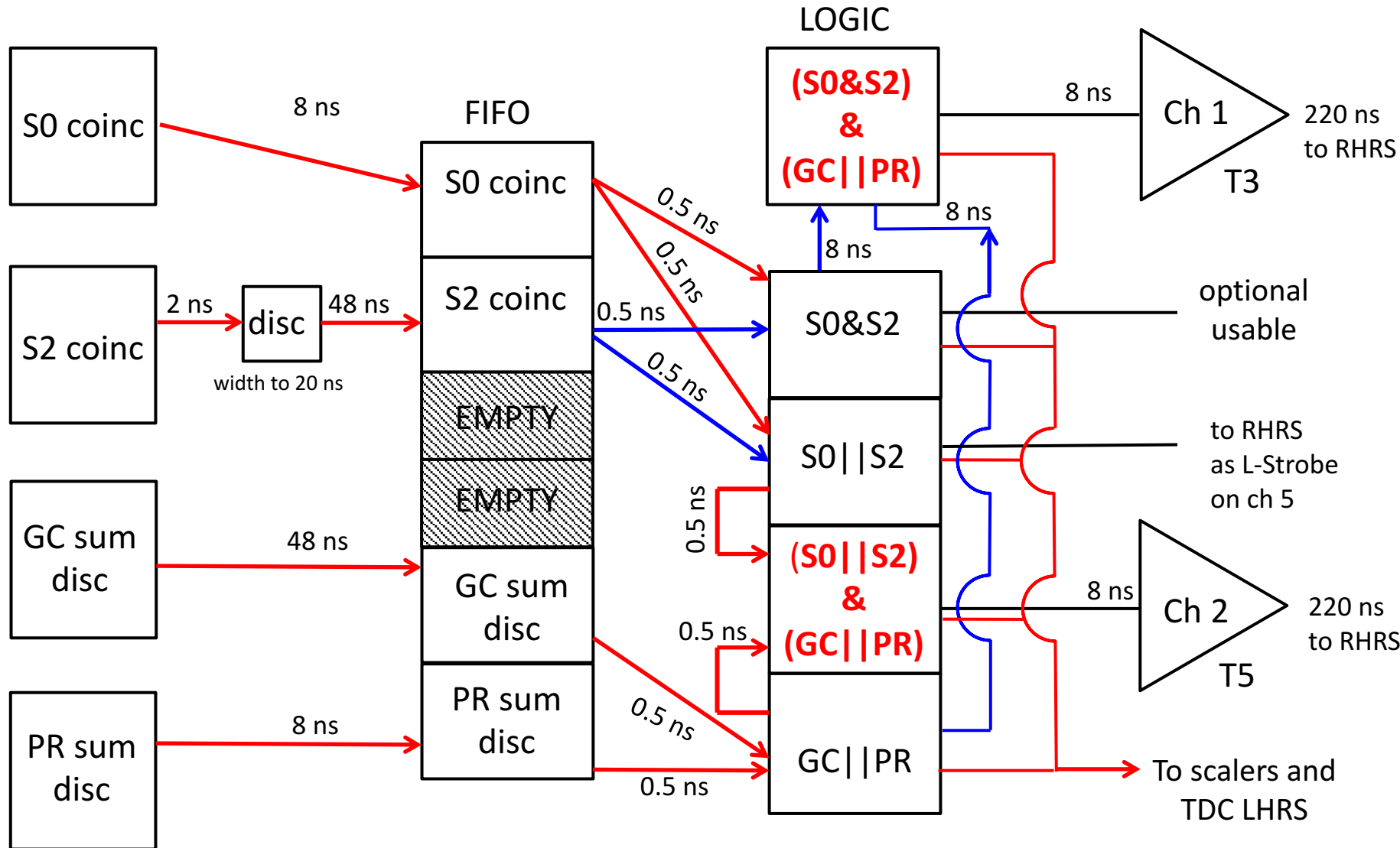

GC: Gas Cherenkov

PR: Pion Rejector

LHRS: S0 & S2 Coincidence

before changes

S0 (blue)

S2 (yellow)

S0 defines time

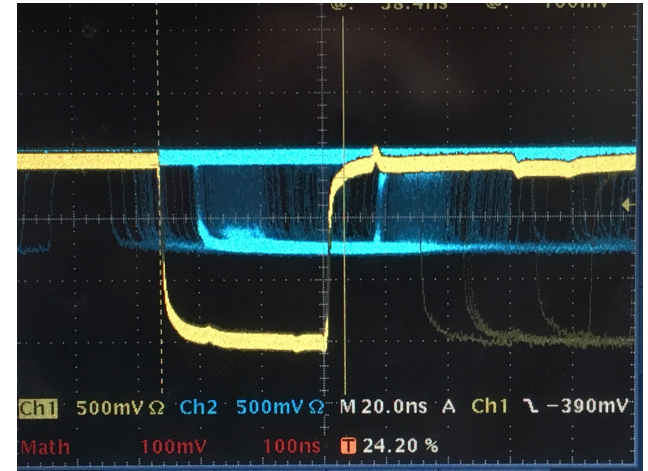

after changes

S0 (blue)

S2 (yellow)

S2 defines time

→ better timing

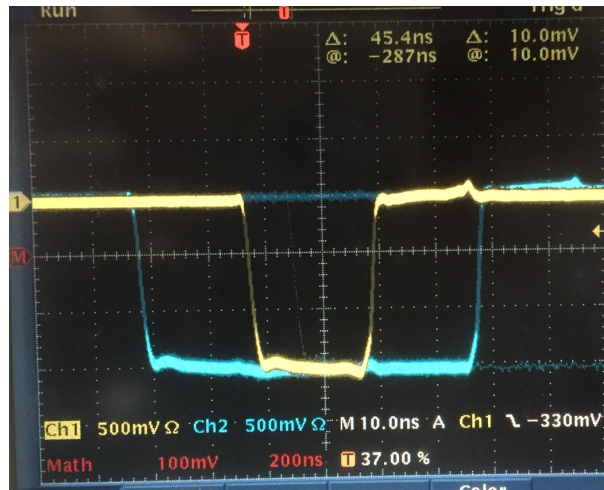

clock

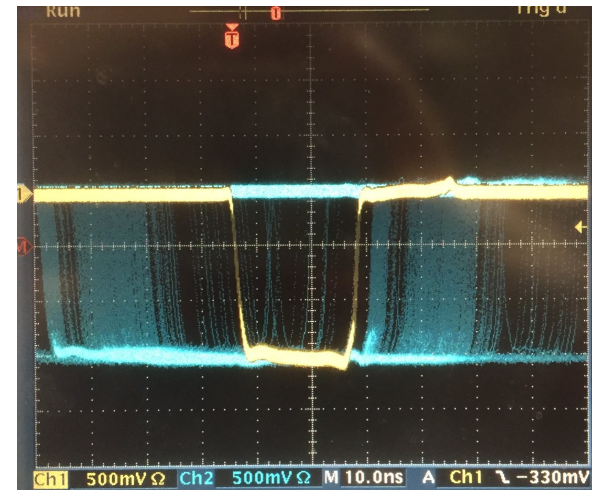

cosmics

LHRS Trigger Pictures

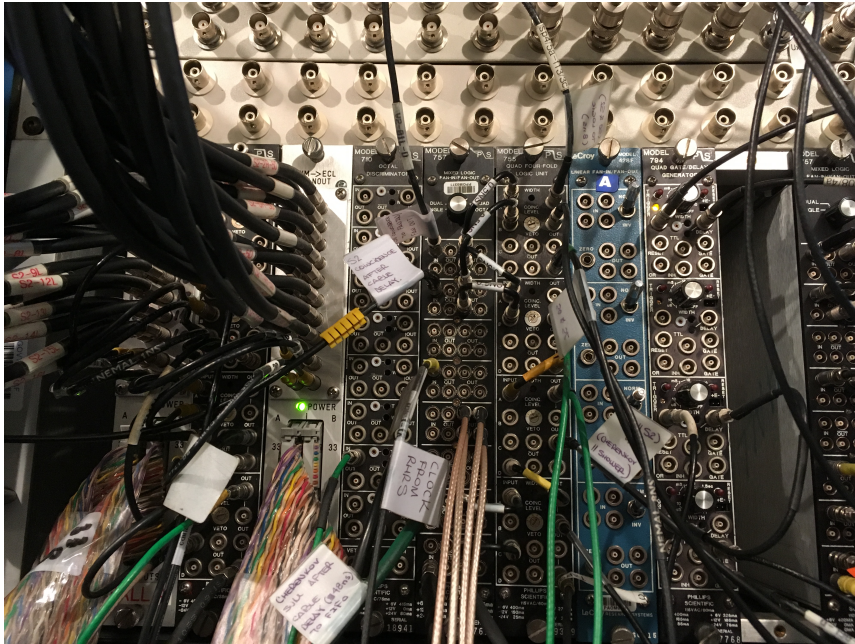

Middle Rack (R2),
Top NIM Crate (N1)
Modules 2 - 11

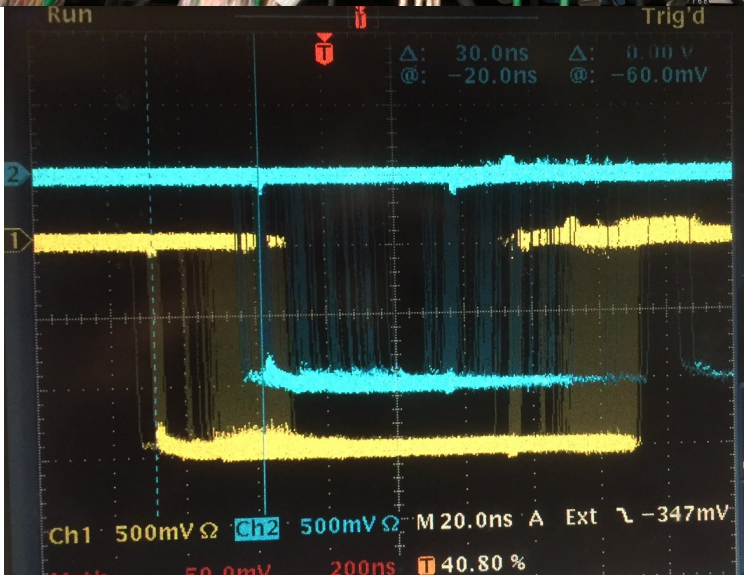

External trigger S0&S2

S0|S2 (yellow)
GC|PR (blue)

Schematics of Trigger Setup RHRS

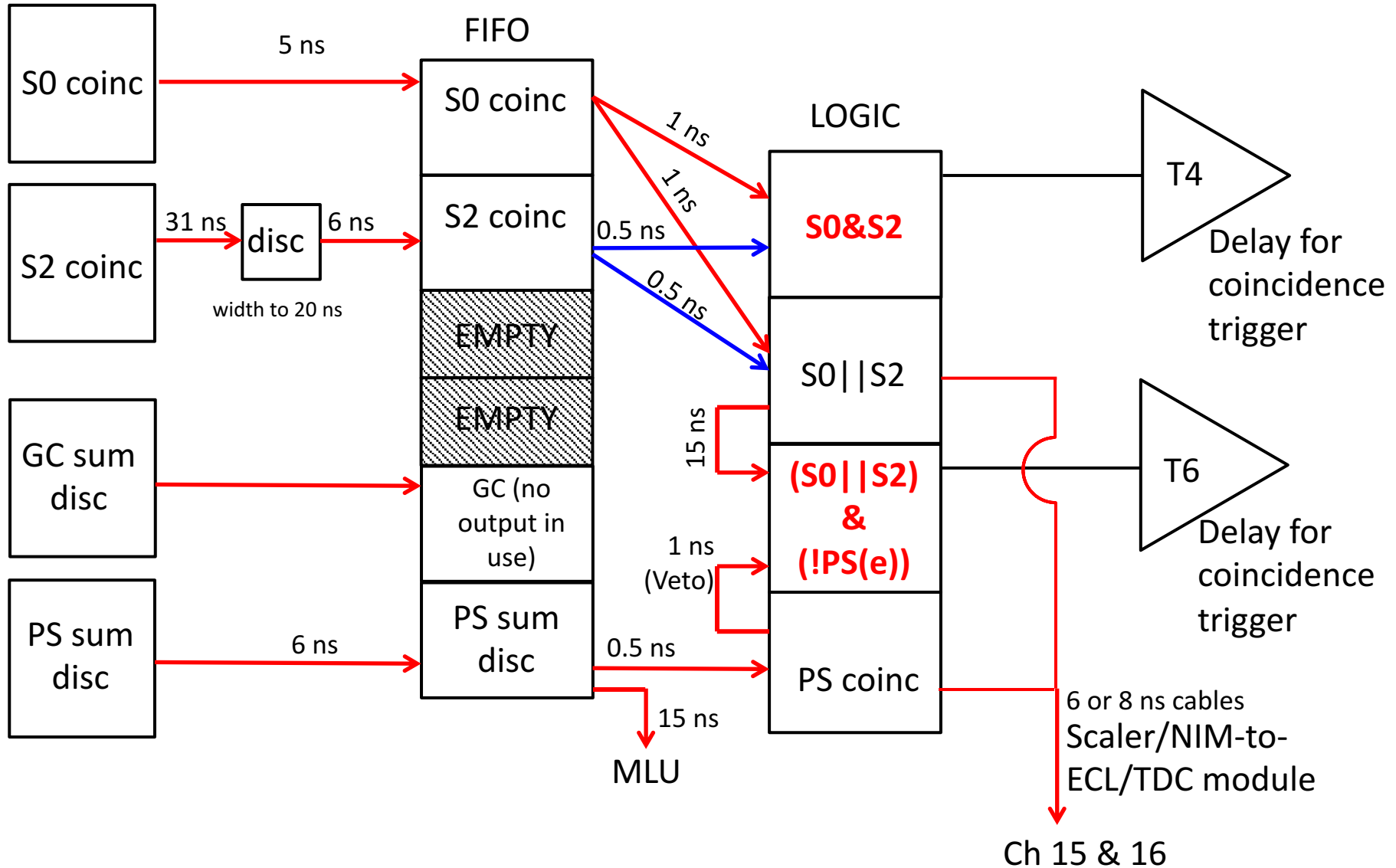

GC: Gas Cherenkov

PS: Preshower/shower

RHRS: S0 & S2 Coincidence

before changes

S0 (blue)

S2 (yellow)

S0 defines time

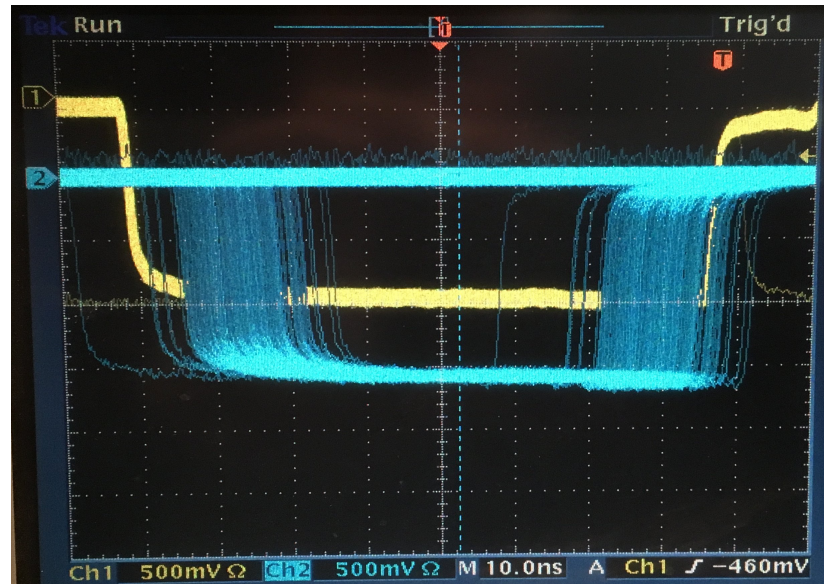

after changes

S0 (yellow)

S2 (blue)

S2 defines time

→ better timing

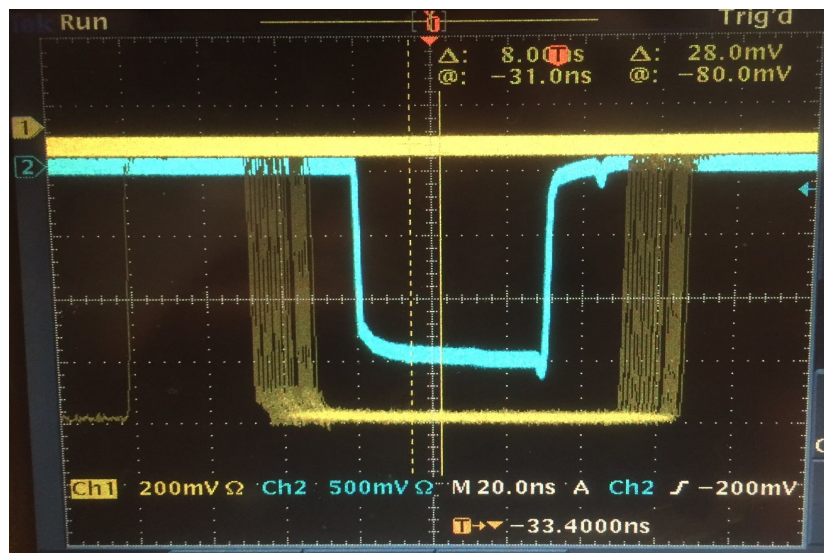

RHRS Trigger Pictures

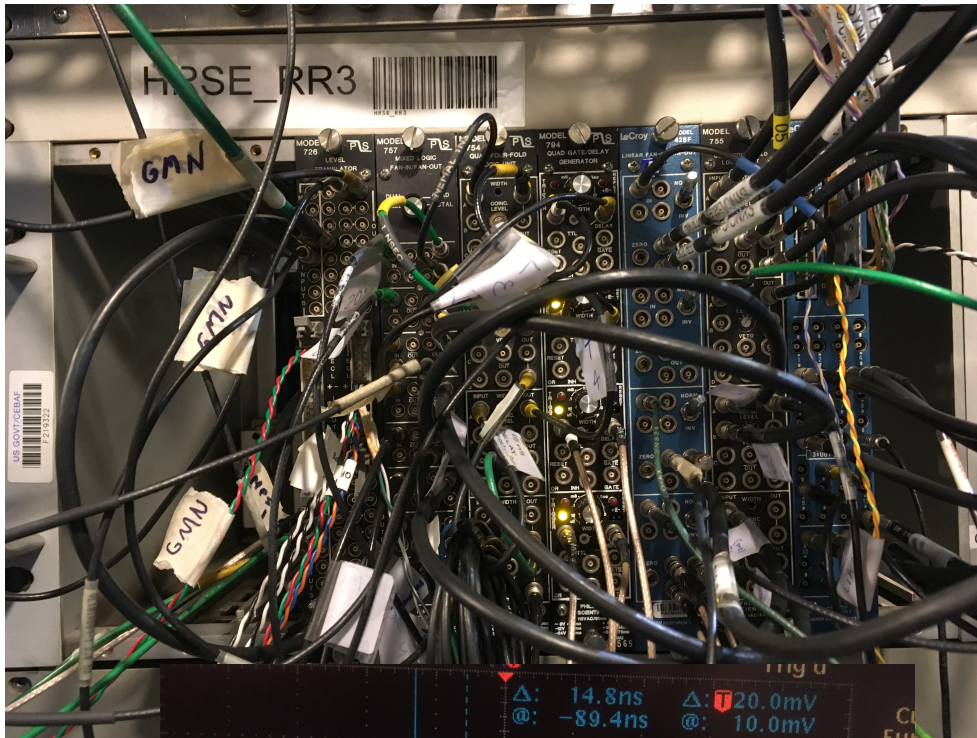

Middle Rack (R3),
Top NIM Crate (N1)
Modules 4 - 9

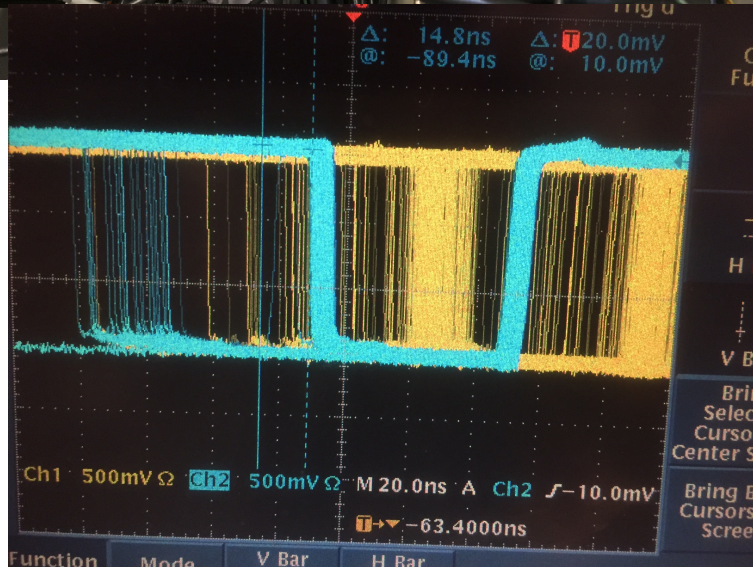

Test PS veto

S0|S2 (yellow)
PS (blue)

Coincidence Schematics (on RHRS R3, N1)

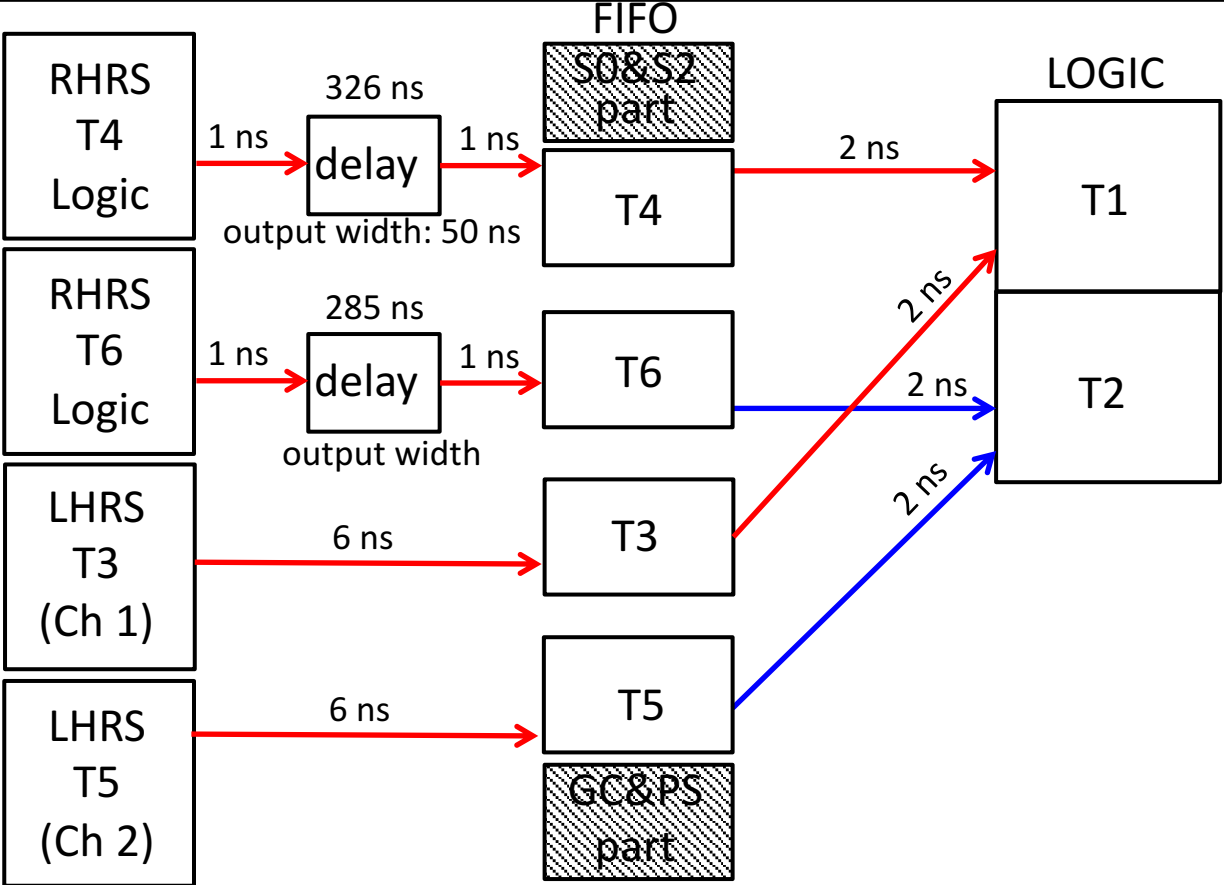

Delay: Delay generator

Coincidence Trigger

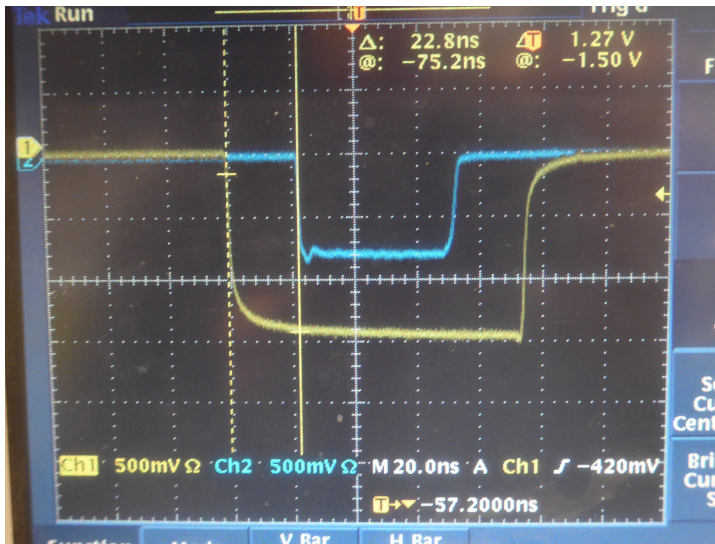

T1 coincidence

T3 (yellow)

T4 (blue)

→ Coincidence window and signal width changed later

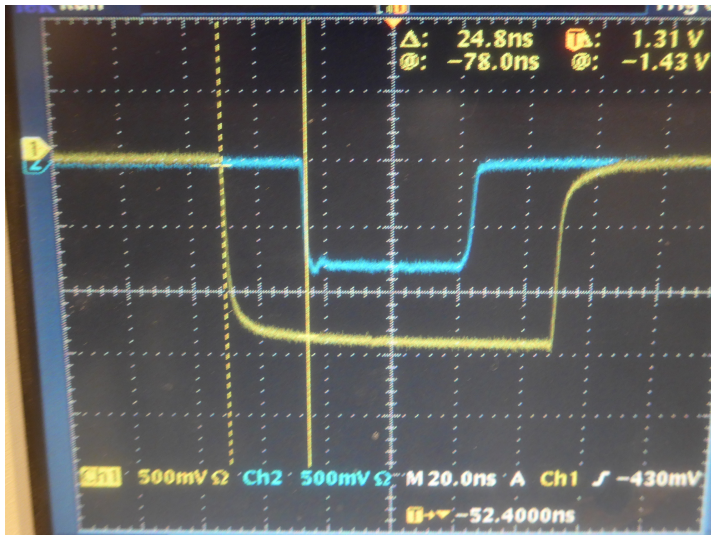

T2 coincidence

T5 (yellow)

T6 (blue)

→ Coincidence window and signal width changed later

→ Coincidence simulation with clock

Coincidence Schematics (on RHRS R3, N1)

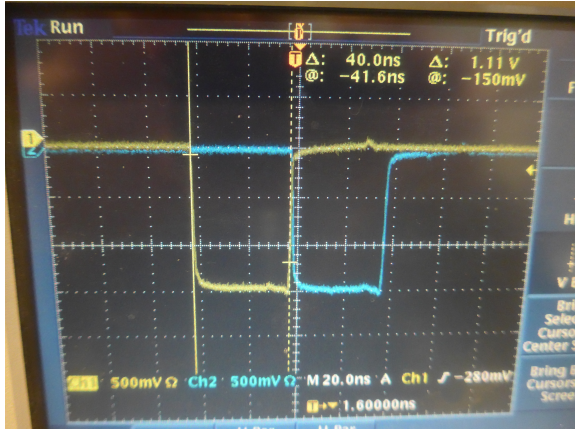
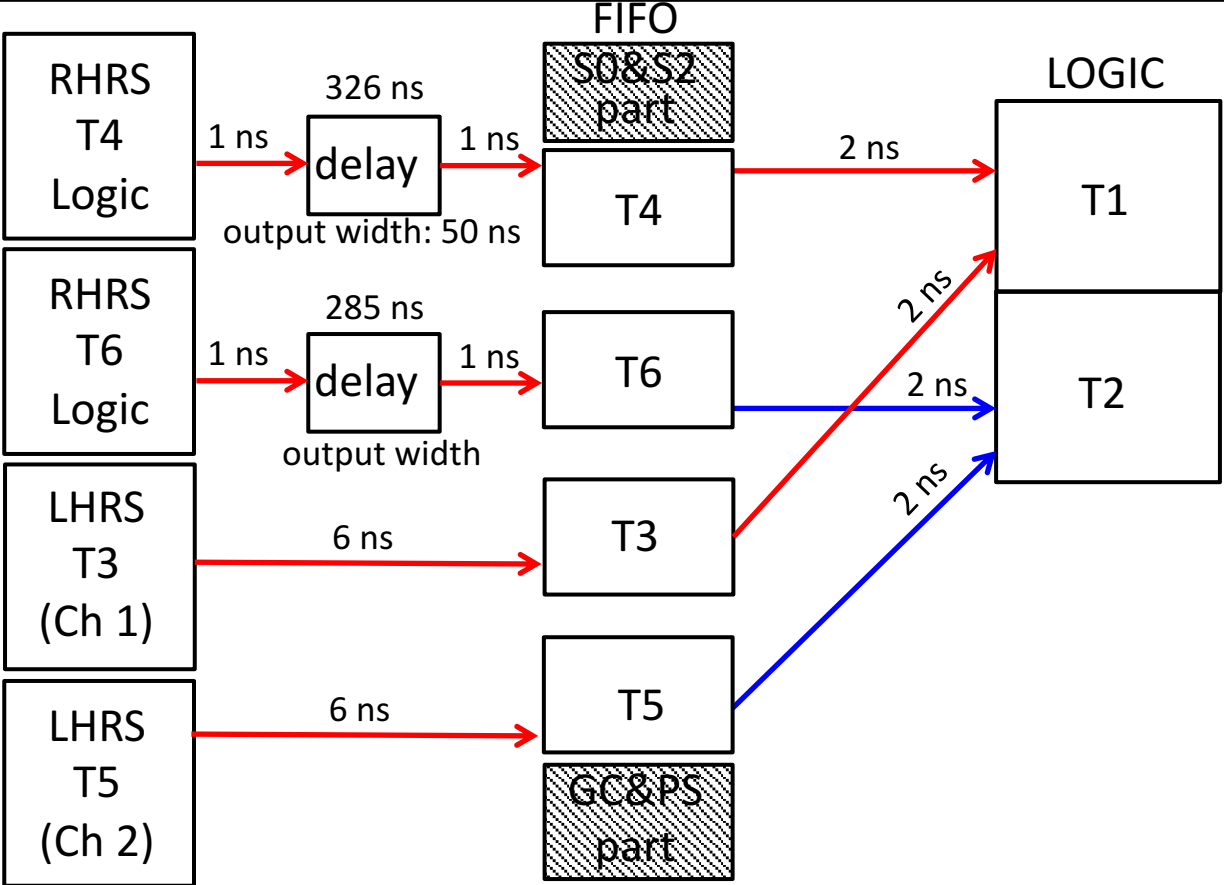

T1 (blue)

T2 (yellow)

→ want to have other order

- Delay of all trigger with respect to T1 to get order **T1 – T3 – T2 – T5 – T4 – T6**
- Trigger Supervisor (TS) minimum time difference 10 ns
- $T3 - T1 = 10 \text{ ns}$, $T2 - T3 = 15 \text{ ns}$, $T5 - T2 = 15 \text{ ns}$, rest same
- $T6 - T1 = 70 \text{ ns}$ (Note: By mistake the differences to T5 and T6 were smaller than wanted)

Delay: Delay generator

Coincidence Schematics (continued)

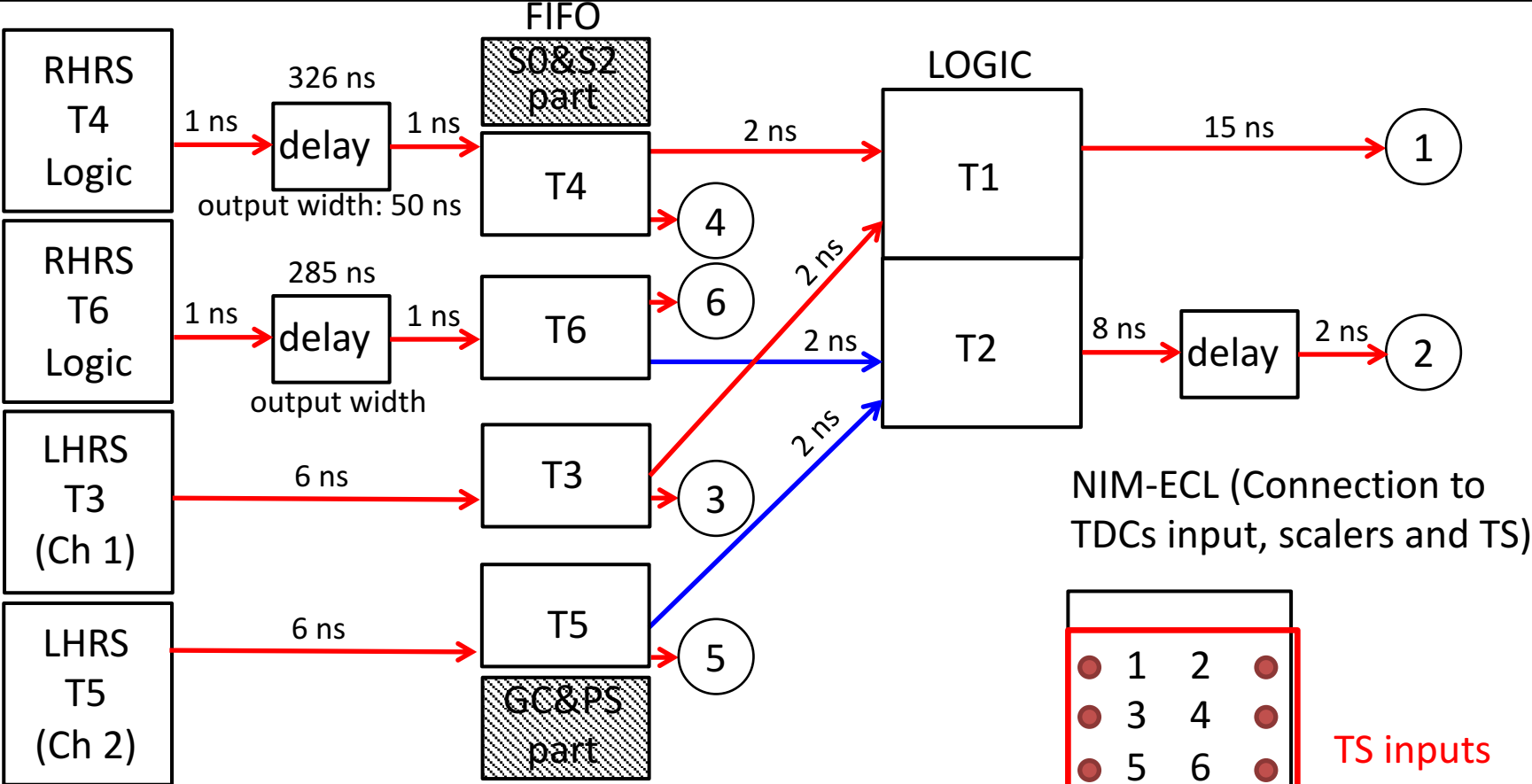

NIM-ECL (Connection to TDCs input, scalers and TS)

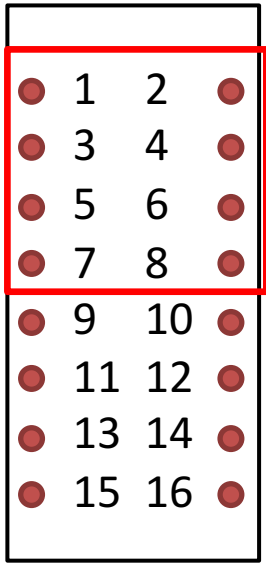

TS inputs

NIM-ECL Connections

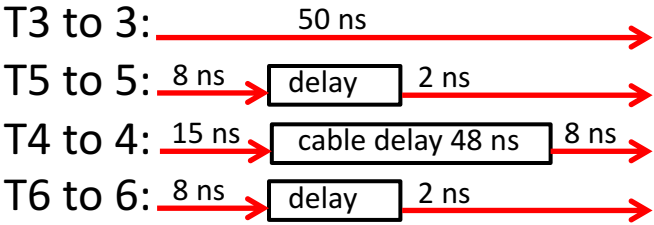

Delay: Delay generator

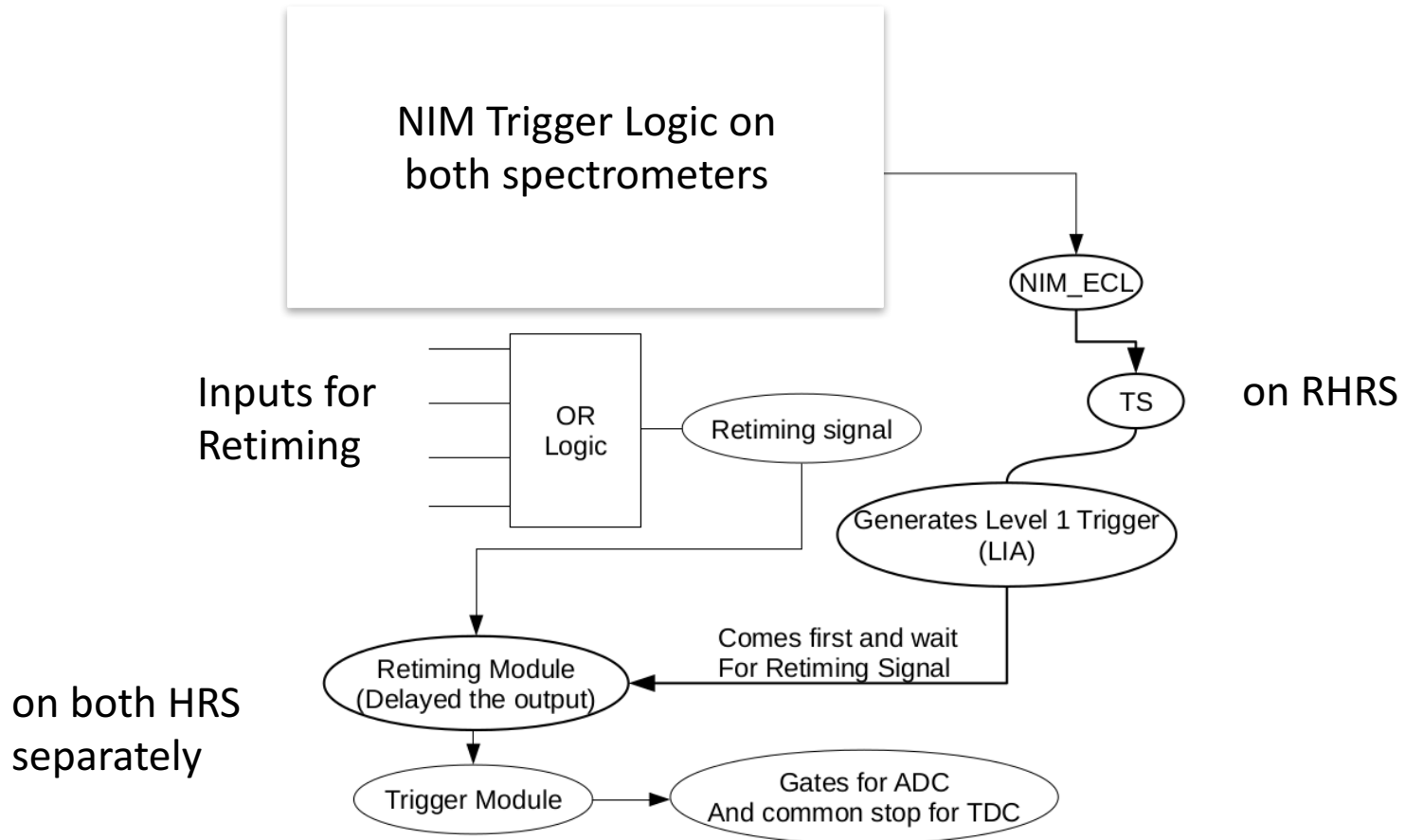

Retiming / Strobe Signal

- Why?
 - Common stop of TDC and ADC gate identical for same events i.e. one peak TDC spectrum
 - Can not be achieved when TDC stop results from L1A signal since it depends on the trigger delays
 - Use independent signal in detector for common stop and ADC
 - Ensure that common stop is existing even for events without a “real” signal i.e. triggered by clock or only on one arm

Retiming / Strobe Signal continued

- How?
 - Use detector information to get common stop
 - Only one Strobe per event and spectrometer (RT module)
 - LHRS strobe: S0 | | S2 (S2 before S0)
 - RHRS strobe: T1 | | T2 | | T3 | | T4 (could be improved)
 - Coincidence with L1A accept (RT module)
 - After 200 ns delayed copy of L1A for coincidence (according to DAQ manual)

Retiming / Strobe Signal continued

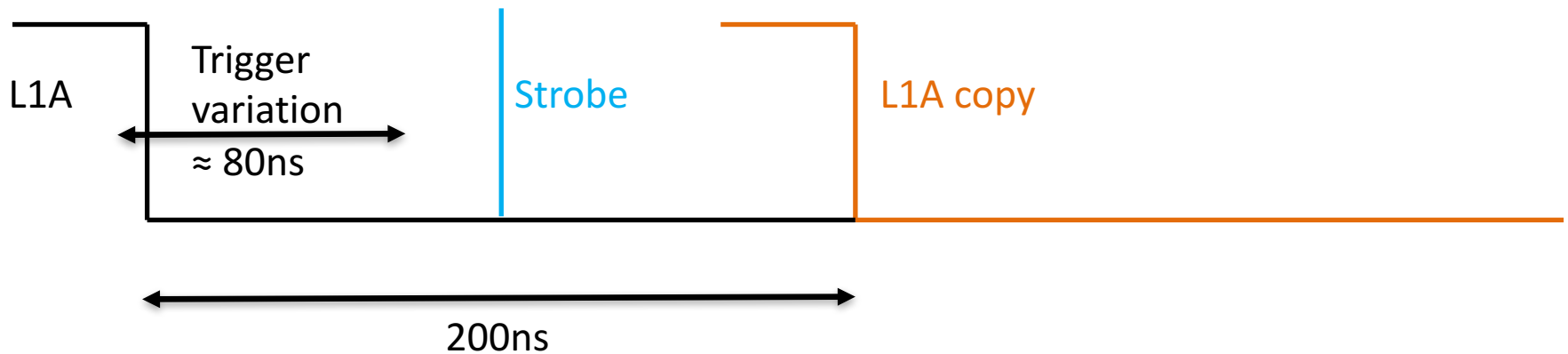

- Strobe between 100 ns to 200 ns after earliest trigger (T1)
- Random accidentals vary more but this gives only flat background \rightarrow does not matter
- Common Stop for TDCs and ADC gate signal is derived from the upper coincidence signal

Retiming / Strobe Signal continued

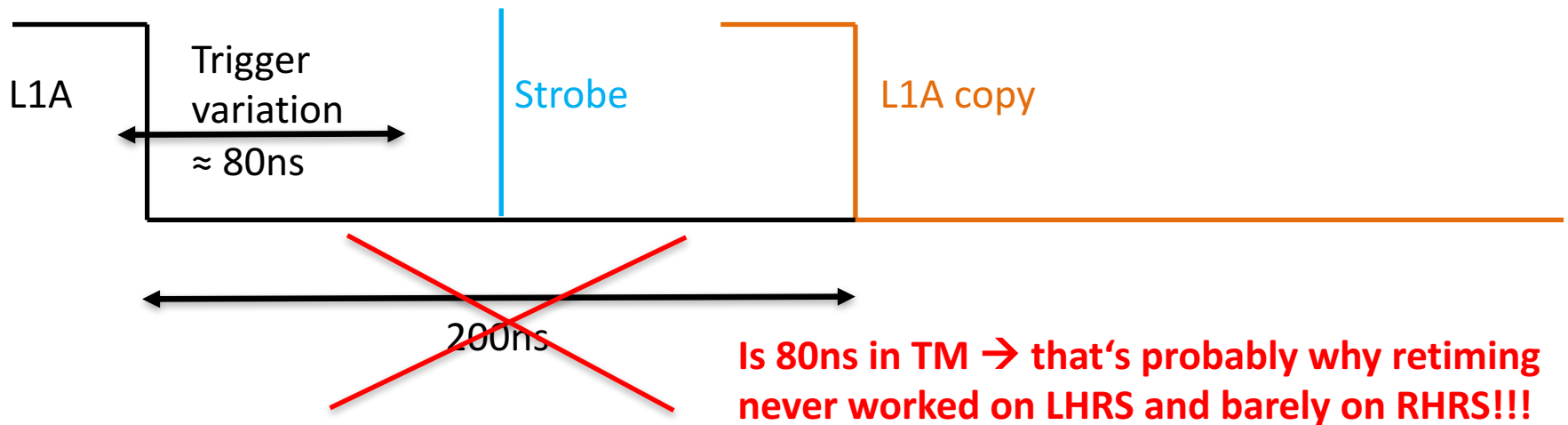

- Strobe between 100 ns to 200 ns after earliest trigger (T1)
- Random accidentals vary more but this gives only flat background → does not matter
- Common Stop for TDCs and ADC gate signal is derived from the upper coincidence signal

LHRS Strobe

S0 || S2 = Strobe

S0 (blue)

S2 (yellow)

S2 defines time of strobe

Strobe is sent to delay generator

for coincidence with L1A

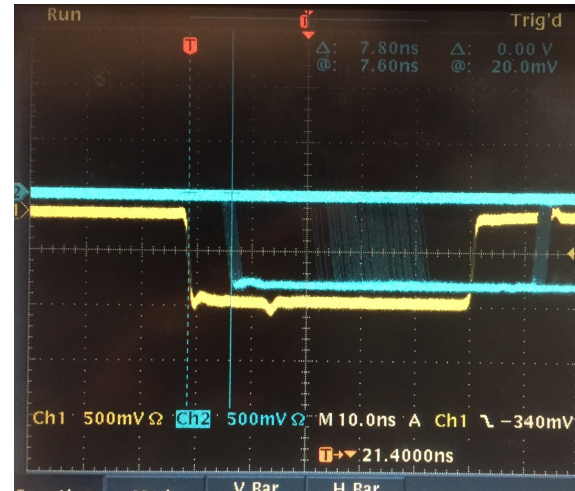

L1A and Strobe Timing

Strobe (blue)

L1A (yellow), T3 trigger

Strobe 100ns after L1A (changed several times later)

Strobe (before delay) is sent to RHRS (ch 5) into TDC & scaler to get coincidence retiming → ideally L-strobe stopped by R-strobe

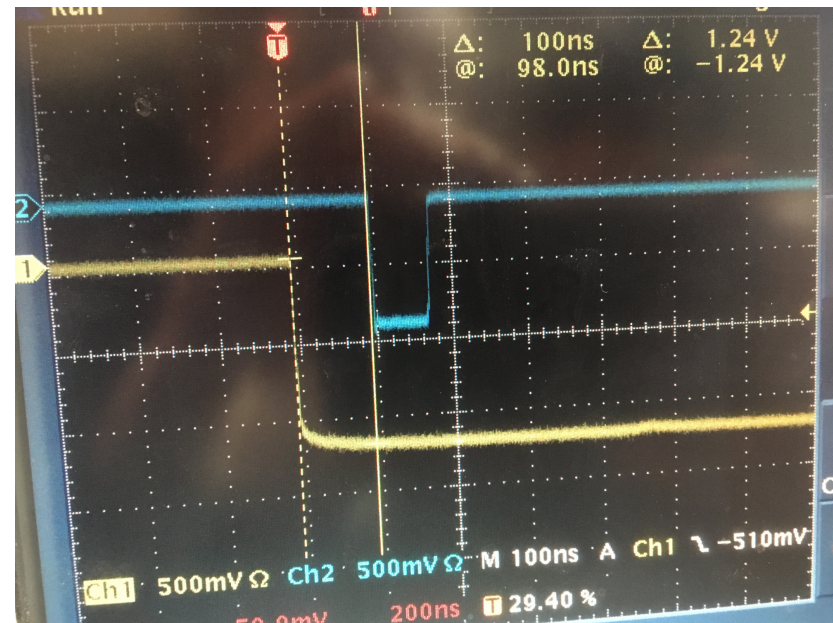

RHRS Strobe

T1||T2||T3||T4 = Strobe

No picture available

L1A and Strobe Timing

Strobe (blue)

L1A (yellow), T4 trigger

Strobe 100ns after L1A (changed later)

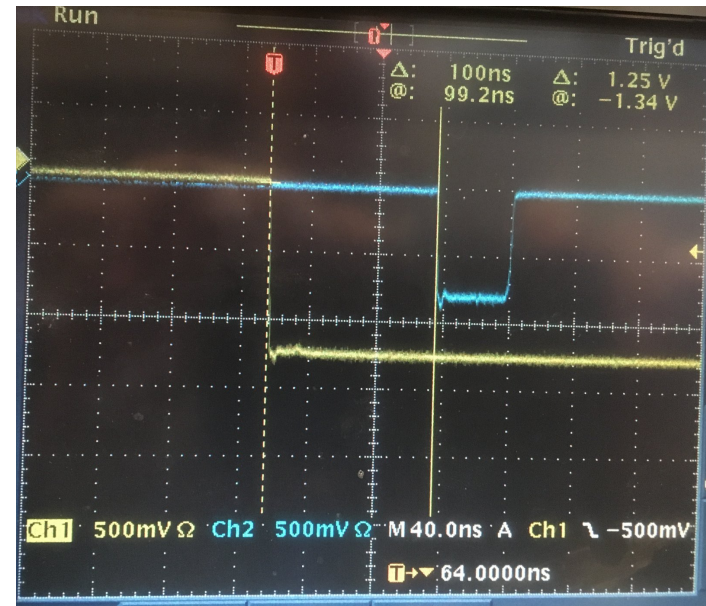

ADC Gates

LHRS Gate

S0 PMT signal (blue)
ADC gate (yellow)

Broad ADC gate (>300ns)
Most of the signal is cross talk
probably induced by EDTM (was
better after we switched it off)

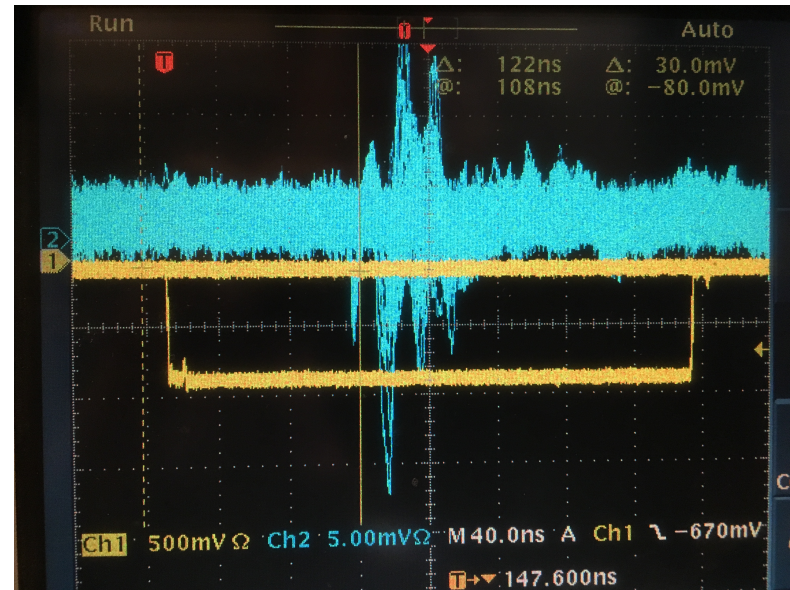

RHRS Gate

S0 PMT signal (blue)
ADC gate (yellow)

Change of ADC gate width to
400ns on **both arms** on 02/24/17

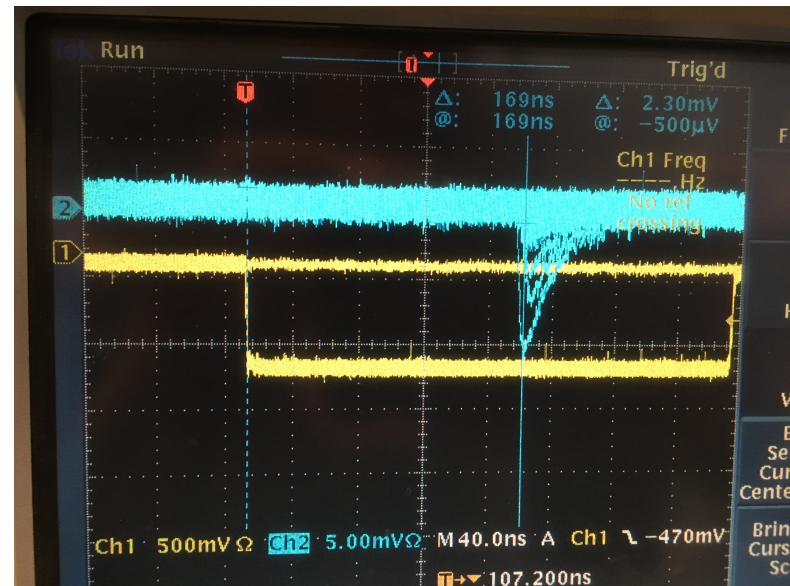

Outlook

- Overview over modifications through beam time
- Mistakes and what to avoid
- Further improvements for next beam times